

1. Description

These N-Channel enhancement mode power field effect transistors are produced using KIA's proprietary, planar stripe, DMOS technology. This advanced technology has been especially tailored to minimize on-state resistance, provide superior switching performance, and withstand high energy pulse in the avalanche and commutation mode. These devices are well suited for low voltage applications such as automotive, DC/DC converters, and high efficiency switching for power management in portable and battery operated products.

2. Features

- 65A, 60V, $R_{DS(on)} = 0.016\Omega @ V_{GS} = 10\text{ V}$
- Low gate charge (typical 48nC)
- Low Crss (typical 32.5pF)
- Fast switching
- 100% avalanche tested
- Improved dv/dt capability
- 175° maximum junction temperature rating

3. Pin configuration

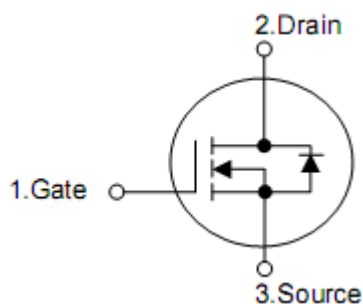
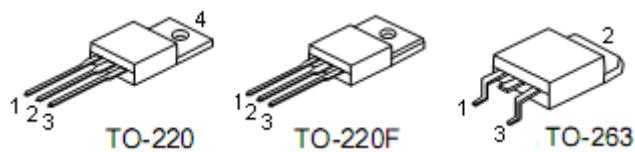

Pin	Function
1	Gate
2	Drain
3	Source
4	Drain

4. Absolute maximum ratings

($T_C = 25\text{ }^\circ\text{C}$, unless otherwise specified)

Parameter	Symbol	Rating	Units
Drain-source voltage	V_{DSS}	60	V
Drain current	I_D	$T_C = 25\text{ }^\circ\text{C}$	A
		$T_C = 100\text{ }^\circ\text{C}$	A
Drain current pulsed (note 1)	I_{DM}	260	A
Gate-source voltage	V_{GSS}	± 20	V
Single pulsed avalanche energy (note 2)	E_{AS}	650	mJ
Avalanche current (note 1)	I_{AR}	65	A
Repetitive avalanche energy (note 1)	E_{AR}	15.0	mJ
Peak diode recovery dv/dt (note 3)	dv/dt	7.0	V/ns
Power dissipation	P_D	$T_C = 25\text{ }^\circ\text{C}$	W
		derate above $25\text{ }^\circ\text{C}$	W/ $^\circ\text{C}$
Operating and Storage temperature range	T_J, T_{STG}	-55 ~ +175	$^\circ\text{C}$
Maximum lead temperature for soldering purposes, 1/8" from case for 5 seconds	T_L	300	$^\circ\text{C}$

5. Thermal characteristics

Parameter	Symbol	Min	Max	Unit
Thermal resistance, Junction-to-case	$R_{\theta JC}$		1.00	$^\circ\text{C}/\text{W}$
Thermal resistance, case-to-sink	$R_{\theta CS}$	0.5		$^\circ\text{C}/\text{W}$
Thermal resistance, Junction-to-ambient	$R_{\theta JA}$		62.5	$^\circ\text{C}/\text{W}$

6. Electrical characteristics

(T_J=25°C, unless otherwise notes)

Parameter	Symbol	Conditions	Min	Typ	Max	Unit
Off characteristics						
Drain-source breakdown voltage	BV _{DSS}	V _{GS} =0V, I _D =250μA	60			V
Breakdown voltage temperature coefficient	ΔBV _{DSS} /ΔT _J	I _D =250μA, referenced to 25 °C		0.07		V/°C
Zero gate voltage drain current	I _{DSS}	V _{DS} =60V, V _{GS} =0V			1	μA
		V _{DS} =48V, T _C =150°C			10	μA
Gate-body leakage current	Forward	I _{GSSF}			100	nA
	Reverse	I _{GSSR}			-100	nA
On characteristics						
Gate threshold voltage	V _{GS(th)}	V _{DS} =V _{GS} , I _D =250μA	2.0		4.0	V
Static drain-source on-resistance	R _{DS(on)}	V _{GS} =10V, I _D =39A		0.015	0.016	Ω
Forward transconductance	g _{FS}	V _{DS} =25V, I _D =32.5A (note4)			100	S
Dynamic characteristics						
Input capacitance	C _{iss}	V _{DS} =25V, V _{GS} =0V, f=1.0MHz		2000		pF
Output capacitance	C _{oss}			450		pF
Reverse transfer capacitance	C _{rss}			32.5		pF
Switching characteristics						
Turn-on delay time	t _{d(on)}	V _{DD} =30V, I _D =39A, R _G =4.7Ω R _D =0.77Ω, V _{GS} =10V (note4,5)		12		ns
Turn-on rise time	t _r			33		ns
Turn-off delay time	t _{d(off)}			41		ns
Turn-off fall time	t _f			12		ns
Total gate charge	Q _g	V _{DS} =30V, I _D =39A, V _{GS} =10V, (note4,5)		40		nC
Gate-source charge	Q _{GS}			8		nC
Gate-drain charge	Q _{gd}			12		nC
Drain-source diode characteristics and maximum rating						
Maximum continuous drain-source diode forward current	I _S				65	A
Maximum pulsed drain-source diode forward current	I _{SM}				260	A
Drain-source diode forward voltage	V _{SD}	V _{GS} =0V, I _S =65A			1.5	V
Reverse recovery time	t _{rr}	V _{GS} =0V, I _S =65A		60		ns
Reverse recovery charge	Q _{rr}	di _F /dt=100A/μs (note4)		100		μC

Note: 1. repetitive rating: pulse width limited by maximum junction temperature

2. L=180μH, I_{AS}=65A, V_{DD}=25V, R_G=25Ω, starting T_J=25°C

3. I_{SD}≤65A, di/dt≤100A/μs, V_{DD}≤BV_{DSS}, starting T_J=25 °C

4. Pulse test: pulse width≤300μs, duty cycle≤2%

5. Essentially independent of operating temperature

7. Test circuits and waveforms

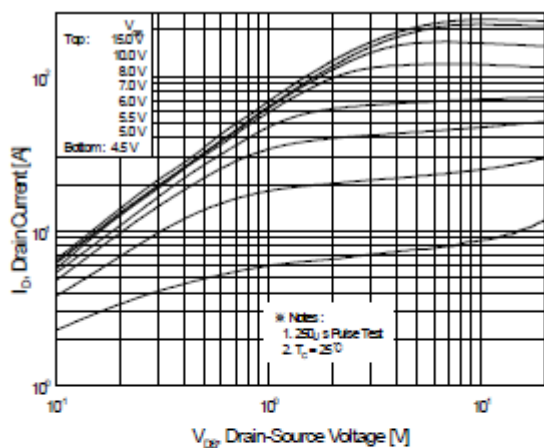

Figure 1. On-Region Characteristics

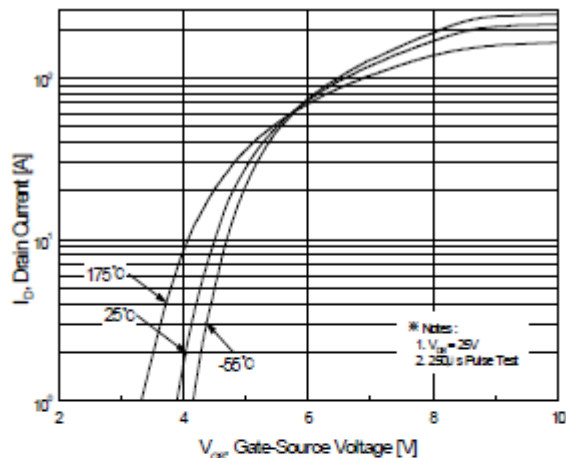

Figure 2. Transfer Characteristics

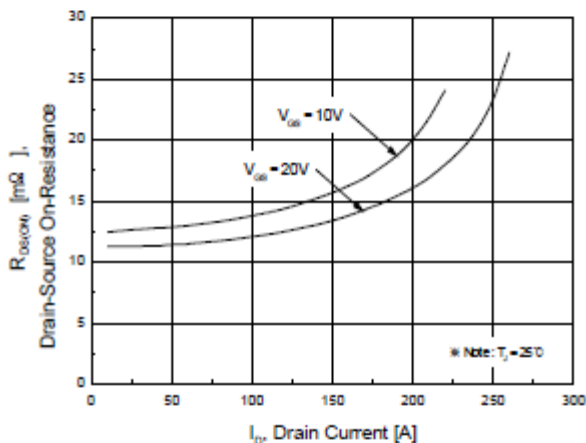

Figure 3. On-Resistance Variation vs. Drain Current and Gate Voltage

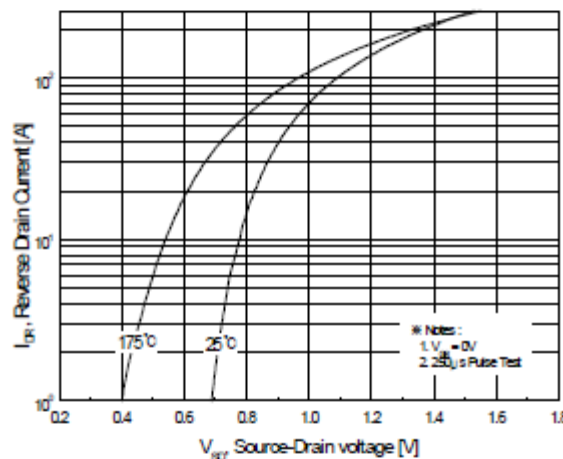

Figure 4. Body Diode Forward Voltage Variation vs. Source Current and Temperature

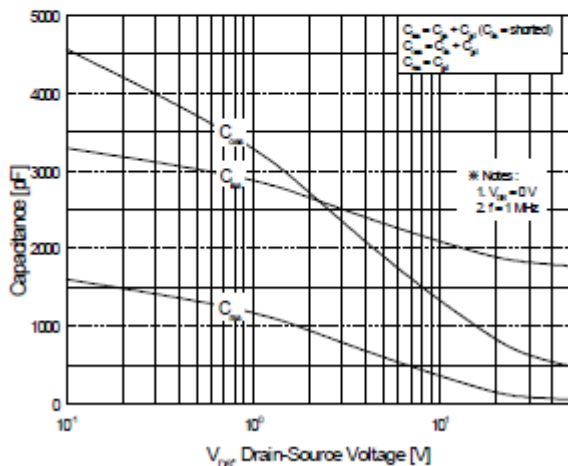

Figure 5. Capacitance Characteristics

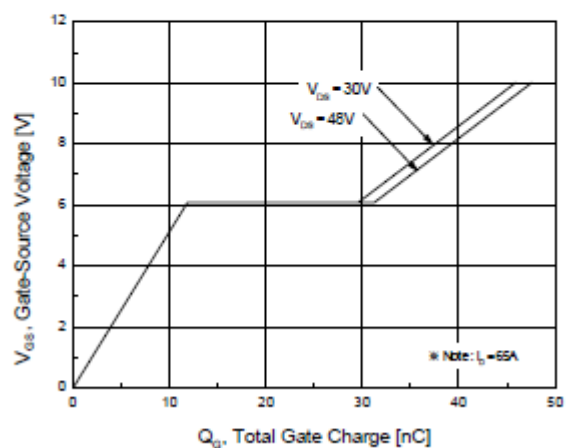

Figure 6. Gate Charge Characteristics

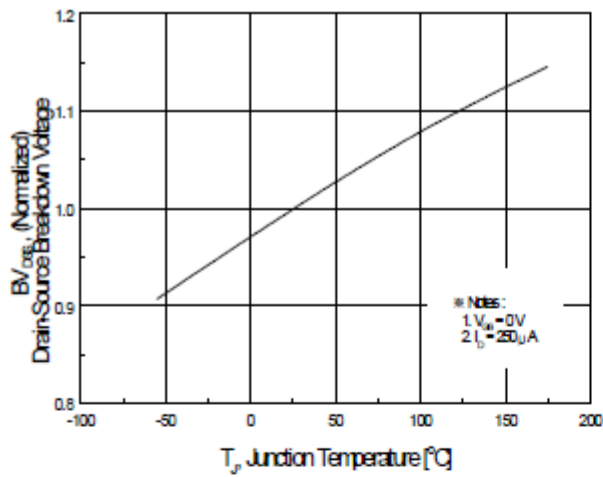

Figure 7. Breakdown Voltage Variation vs. Temperature

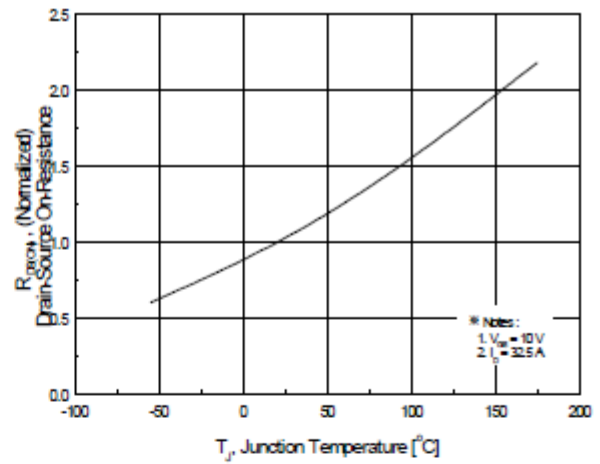

Figure 8. On-Resistance Variation vs. Temperature

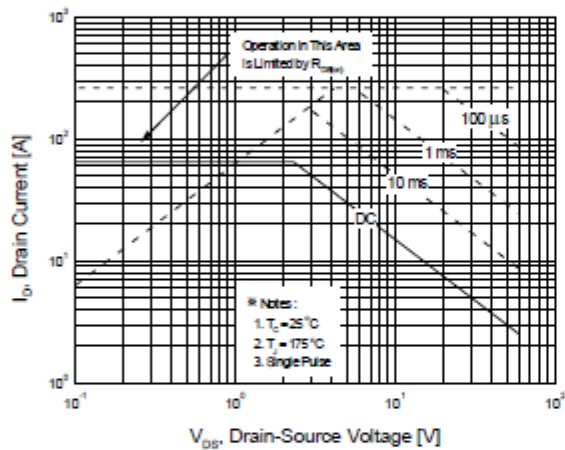

Figure 9. Maximum Safe Operating Area

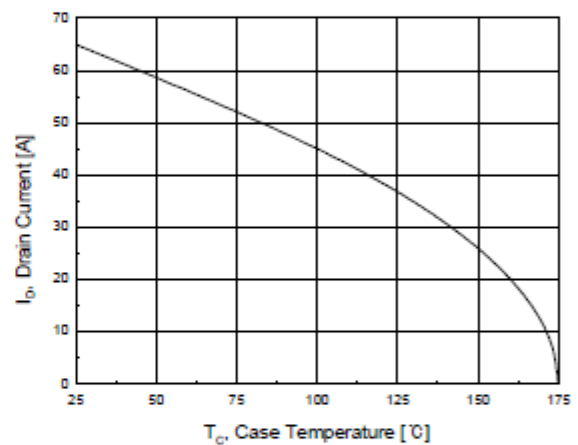

Figure 10. Maximum Drain Current vs. Case Temperature

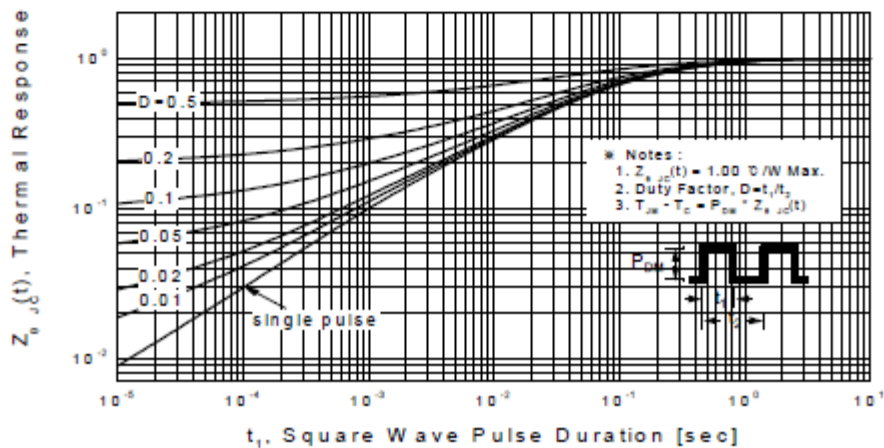
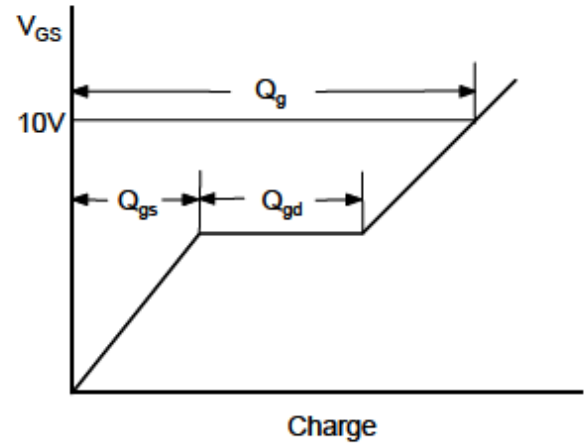
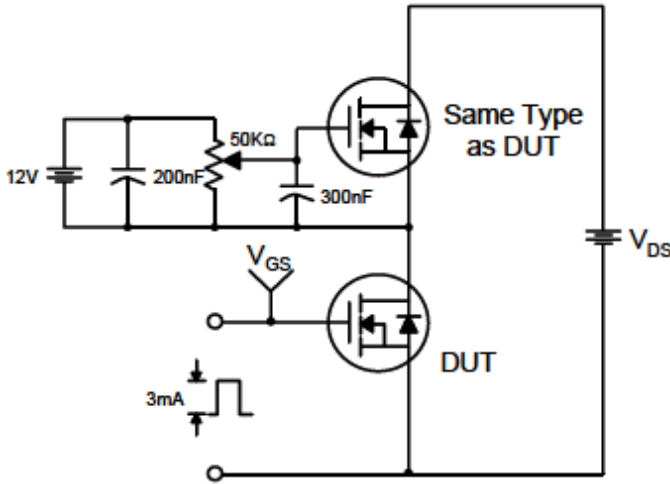
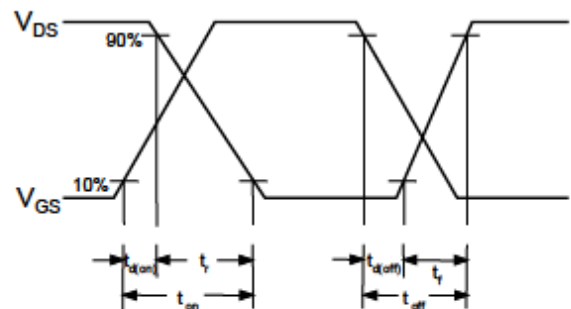
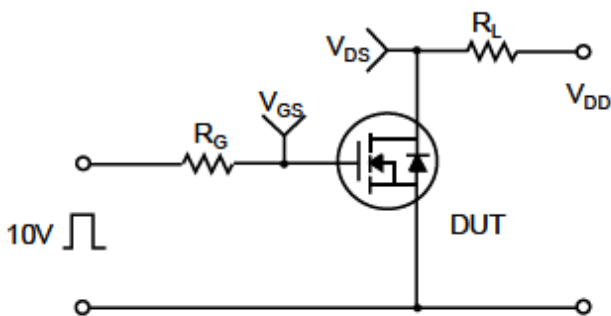

Figure 11. Transient Thermal Response Curve

Gate Charge Test Circuit & Waveform



Resistive Switching Test Circuit & Waveforms



Unclamped Inductive Switching Test Circuit & Waveforms

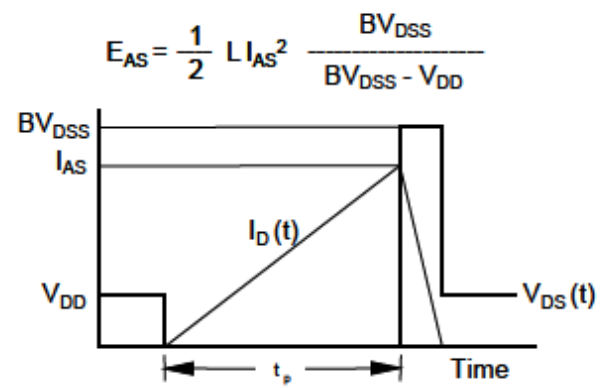
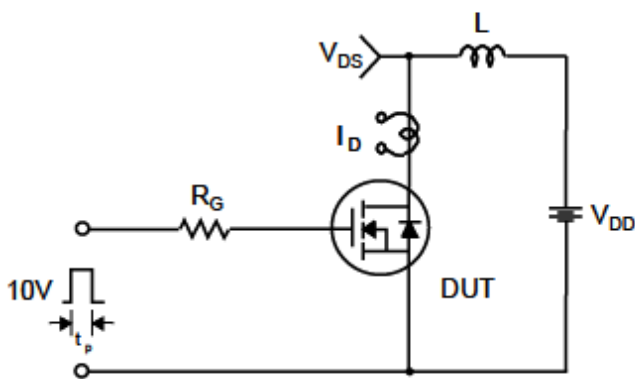

Peak Diode Recovery dv/dt Test Circuit & Waveforms

