

DC MOTOR SPEED CONTROLLER FOR CASSETTE TAPE RECORDER SYSTEM

The KIA6903P is a monolithic IC developed for speed control of general purpose DC motors. This IC consist of a reference voltage generator, current multiplier, comparator and start circuit.

The IC controls the speed of a DC motor by detecting counter electromotive force from the DC motor.

FEATURES

- Wide Range of Working Power Supply Voltage.
($V_{CC}=3.5 \sim 18V$)
- Very Large Starting Torque at the low Voltage.
- Large Allowable Loss due to Effective Utilization of Substrate Radiation.
- Usable for Various DC Motors by Means of Changing Constants of the External Components.

APPLICATION

- Radio Cassette Tape Recorders

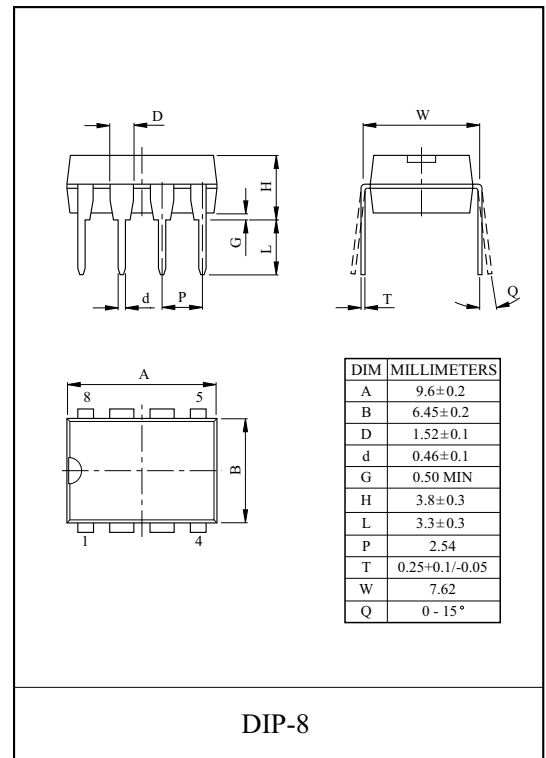

ABSOLUTE MAXIMUM RATINGS ($T_a=25^\circ C$)

PARAMETERS	SYMBOL	LIMITS	UNIT	CONDITIONS
Supply Voltage	V_{CC}	18	V	-
Power Dissipation	P_D	1.4*	W	PCB:9cm ² . T=1.0

Note : Derated above $T_a=25^\circ C$ in the proportion of 11.2mW/ $^\circ C$.

BLOCK DIAGRAM

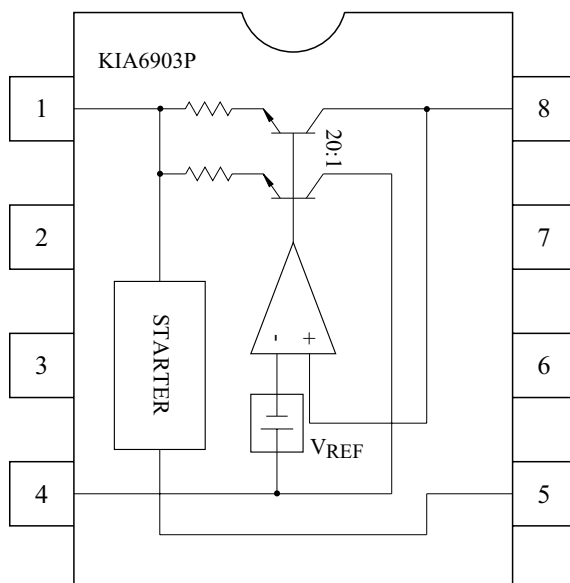

KIA6903P

ELECTRICAL CHARACTERISTICS ($V_{CC}=12V$, $T_a=25^\circ C$)

CHARACTERISTICS	SYMBOL	TEST CIRCUIT	TEST CONDITION	MIN.	TYP.	MAX.	UNIT
Bias Current	I_4	Fig.1(d)	$R_M=180\ \Omega$	0.5	0.8	1.2	mA
Output Saturation Voltage	V_{sat}	Fig.1(c)	$V_{IN}=4.2V$, $R_M=4.4\ \Omega$	-	1.5	2.0	V
Reference Voltage	V_{REF}	Fig.1(a)	$I_M=10mA$	1.10	1.27	1.40	V
Current Ratio	K	Fig.1(b)	$R_{M1}=44\ \Omega$, $R_{M2}=33\ \Omega$	18	20	22	-
Reference Voltage Variance- Power Supply Voltage Variance	$\frac{\Delta V_{REF}}{V_{REF}} / \Delta V_{CC}$	Fig.1(a)	$I_M=100mA$, $V_{CC}=6.3 \sim 18V$	-	0.06	-	%/V
Current Ratio Variance- Power Supply Voltage Variance	$\frac{\Delta K}{K} / \Delta V_{CC}$	Fig.1(b)	$I_M=100mA$, $V_{CC}=6.3 \sim 18V$	-	0.4	-	%/V
Reference Voltage Variance- Motor Current Variance	$\frac{\Delta V_{REF}}{V_{REF}} / \Delta I_M$	Fig.1(a)	$I_M=30 \sim 200mA$	-	-0.02	-	%/mA
Current Ratio Variance- Motor Current Variance	$\frac{\Delta K}{K} / \Delta I_M$	Fig.1(b)	$I_M=30 \sim 200mA$	-	-0.02	-	%/mA
Reference Voltage Variance- Ambient Temperature Variance	$\frac{\Delta V_{REF}}{V_{REF}} / \Delta T_a$	Fig.1(a)	$I_M=100mA$, $T_a=-25 \sim 75^\circ C$	-	0.01	-	%/°C
Current Ratio Variance- Ambient Temperature Variance	$\frac{\Delta K}{K} / \Delta T_a$	Fig.1(b)	$I_M=100mA$, $T_a=-25 \sim 75^\circ C$	-	0.01	-	%/°C

TEST CIRCUIT

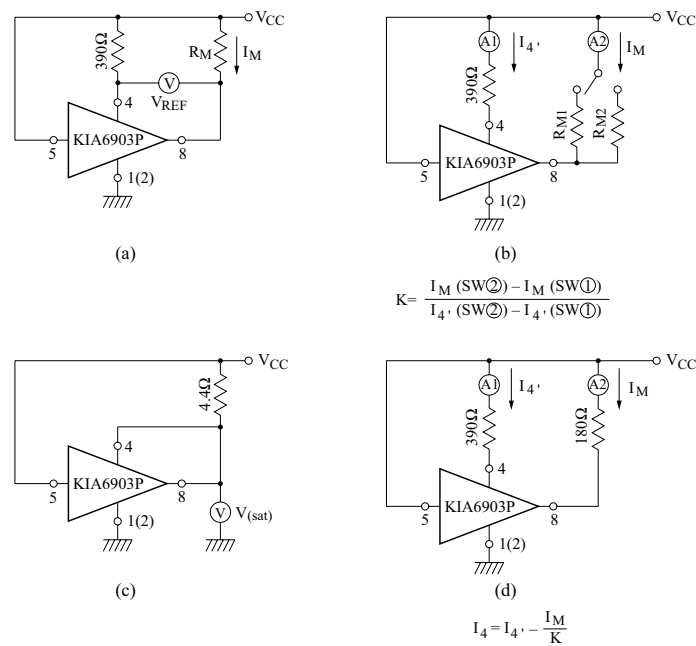
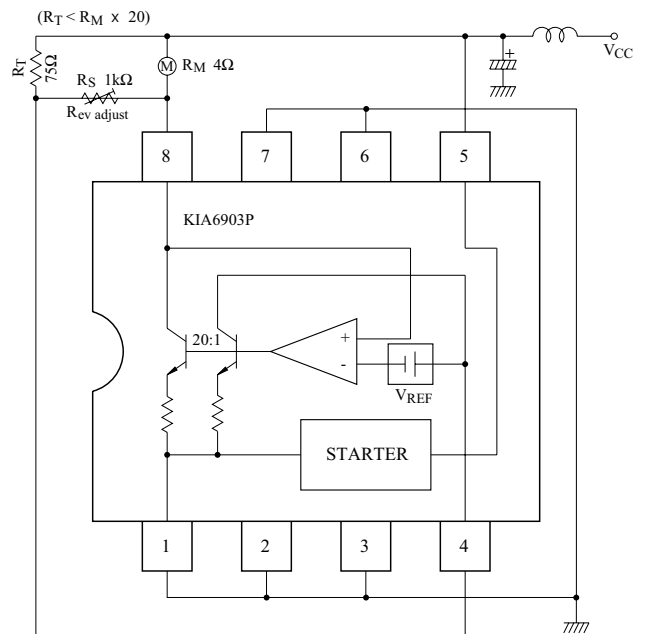

Fig.1

APPLICATION CIRCUIT



* ①, ②, ③, ⑥, ⑦ Pin must be connected with GND