

DUAL PRE AMPLIFIER SYSTEM

The KIA7417AP is a dual preamplifier system IC designed for radio cassette player of the low end class to the middle class.

FEATURES

- Recording Amp with ALC.
- Play Back Amp.
- Mic Amp with ALC.
- Monitor Amp.
- Built-in Switch for Selecting REC/PLAY.
- Built-in Switch for Selecting TAPE input or RADIO(AUX) input.
- Built-in Recording Bias Circuit Control terminal.
- Following 4 modes can be Carried out by External two Switches Combination.
 - Radio Recording.
 - Mic Recording.
 - Radio Play.
 - Tape Play Back.
- Few External Parts.
- Small Package (ZIP-21)
- Operational Supply Voltage (Recommended)
 - : $V_{CC}=3.5\sim 7V$ ($T_a=25^\circ C$)

MAXIMUM RATINGS ($T_a=25^\circ C$)

CHARACTERISTIC	SYMBOL	RATING	UNIT
Supply Voltage	V_{CC}	8	V
Power Dissipation (Note)	P_D	750	mW
Operating Temperature	T_{opr}	-25~75	$^\circ C$
Storage Temperature	T_{stg}	-55~150	$^\circ C$

Note : Derated above $T_a=25^\circ C$ in the proportion of 6mW/ $^\circ C$.

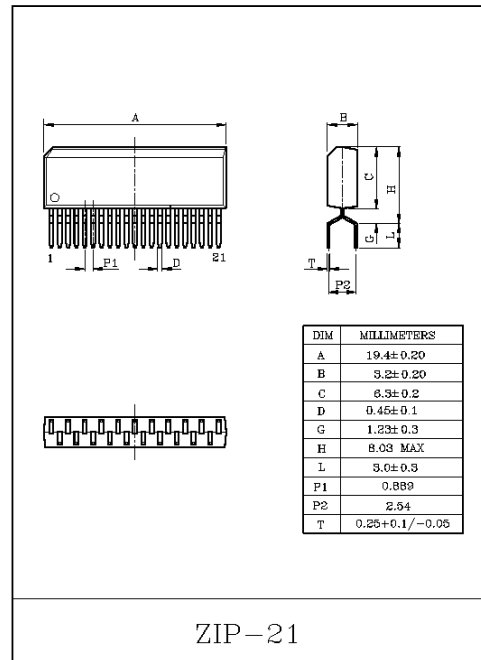

KIA7417AP

ELECTRICAL CHARACTERISTICS

(Unless otherwise specified, $V_{CC}=9V$, $f=1kHz$, $T_a=25^{\circ}C$)

CHARACTERISTIC		SYMBOL	TEST CONDITION	MIN.	TYP.	MAX.	UNIT
Quiescent Current		I_{CC1}	S1=RADIO, S2=PLAY	-	11	16	mA
		I_{CC2}	S1=RADIO, S2=REC	-	14	19	
		I_{CC3}	S1=TAPE, S2=PLAY	-	11	16	
		I_{CC4}	S1=TAPE, S2=REC	-	10	15	
Reference Voltage		V_{ref}		1.8	2.0	2.3	V
MONITOR	Voltage Gain	G_{V1}	$V_{IN}=-50dBV$	14	16	18	dB
	Maximum Output Voltage	V_{omax1}	THD=1%	-	1.3	-	V_{rms}
	Output Noise Voltage	V_{no1}	BW=5~30kHz	-	15	-	μV_{rms}
	Total Harmonic Distortion	THD1	$V_{OUT}=-10dBV$, BW=400~30kHz	-	0.06	-	%
	Cross Talk	CT1	$V_{OUT}=0dBV$, BW=400~30kHz	-	-66	-	dB
	Ripple Rejection Ratio	RR1	$V_{ripple}=-20dBV$, $f=100Hz$	-	-50	-	dB
PLAYBACK	Voltage Gain	G_{V2}	$V_{IN}=-50dBV$	35	38	41	dB
	Open Loop Voltage Gain	G_{VO2}	$V_{IN}=-90dBV$		78		dB
	Maximum Output Voltage	V_{omax2}	THD=1%		1.3		V_{rms}
	Output Noise Voltage	V_{no2}	BW=5~30kHz		80	160	μV_{rms}
	Total Harmonic Distortion	THD2	$V_{OUT}=-10dBV$, BW=400~30kHz		0.02		%
	Cross Talk	CT2	$V_{OUT}=0dBV$, BW=400~30kHz		-77		dB
	Ripple Rejection Ratio	RR2	$V_{ripple}=-20dBV$, $f=100Hz$		-42		dB
REMP	Voltage Gain	G_{V3}	$V_{IN}=-50dBV$	24	27	30	dB
	Output Noise Voltage	V_{no3}	BW=5~30kHz		160		μV_{rms}
	Total Harmonic Distortion	THD3	$V_{OUT}=-10dBV$, BW=400~30kHz		0.04		%
	Cross Talk	CT3	$V_{OUT}=-10dBV$, BW=400~30kHz		-71		dB
	Ripple Rejection	RR3	$V_{ripple}=-20dBV$, $f=100Hz$		-42		dB
	ALC1	ALC31	$V_{IN}=-25dBV$, Dual OP	-6	-2	2	dBV
	ALC2	ALC32	$V_{IN}=-15dBV$, Dual OP		-1		dBV
	ALC3	ALC33	$V_{IN}=-5dBV$, Dual OP		-1		dBV
MIC AMP + REC	Voltage Gain	G_{V4}	$V_{IN}=-80dBV$		63		dB
	Output Noise Voltage	V_{no4}	BW=5~30kHz		3.5	5.6	μV_{rms}
	Total Harmonic Distortion	THD4	$V_{OUT}=-10dBV$, BW=400~30kHz		0.7		%
	Cross Talk	CT4	$V_{OUT}=-10dBV$, BW=400~30kHz		-43		dB
	Ripple Rejection	RR4	$V_{ripple}=-20dBV$, $f=100Hz$		-28		dB
	ALC1	ALC41	$V_{IN}=-60dBV$, Dual OP	-6	-2	2	dBV
	ALC2	ALC42	$V_{IN}=-40dBV$, Dual OP		-1	-	dBV
	ALC3	ALC43	$V_{IN}=-15dBV$, Dual OP	-4	-1	2	dBV

KIA7417AP

BLOCK DIAGRAM

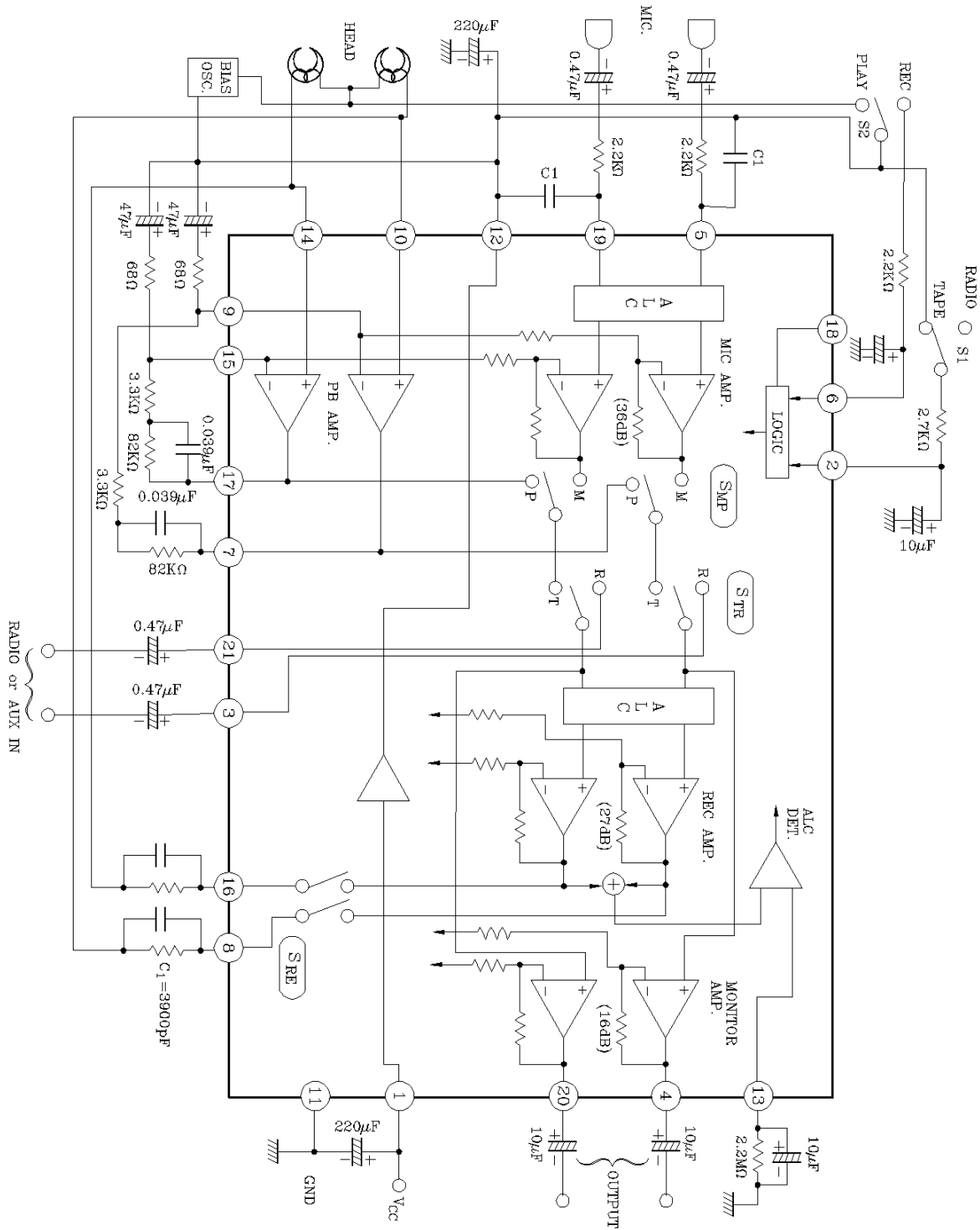

KIA7417AP

TEST CIRCUIT

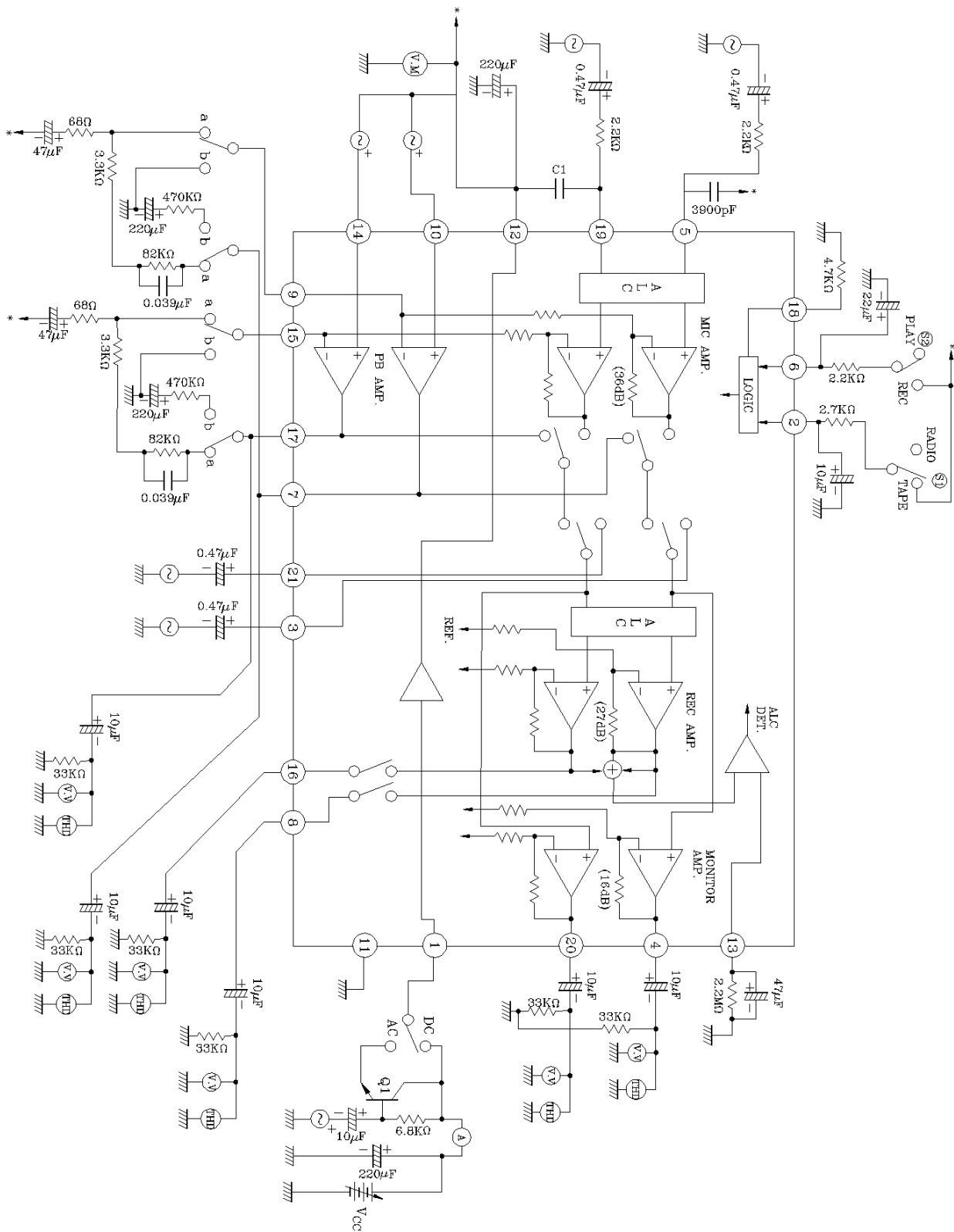

KIA7417AP

APPLICATION CIRCUIT (AC biasing type)

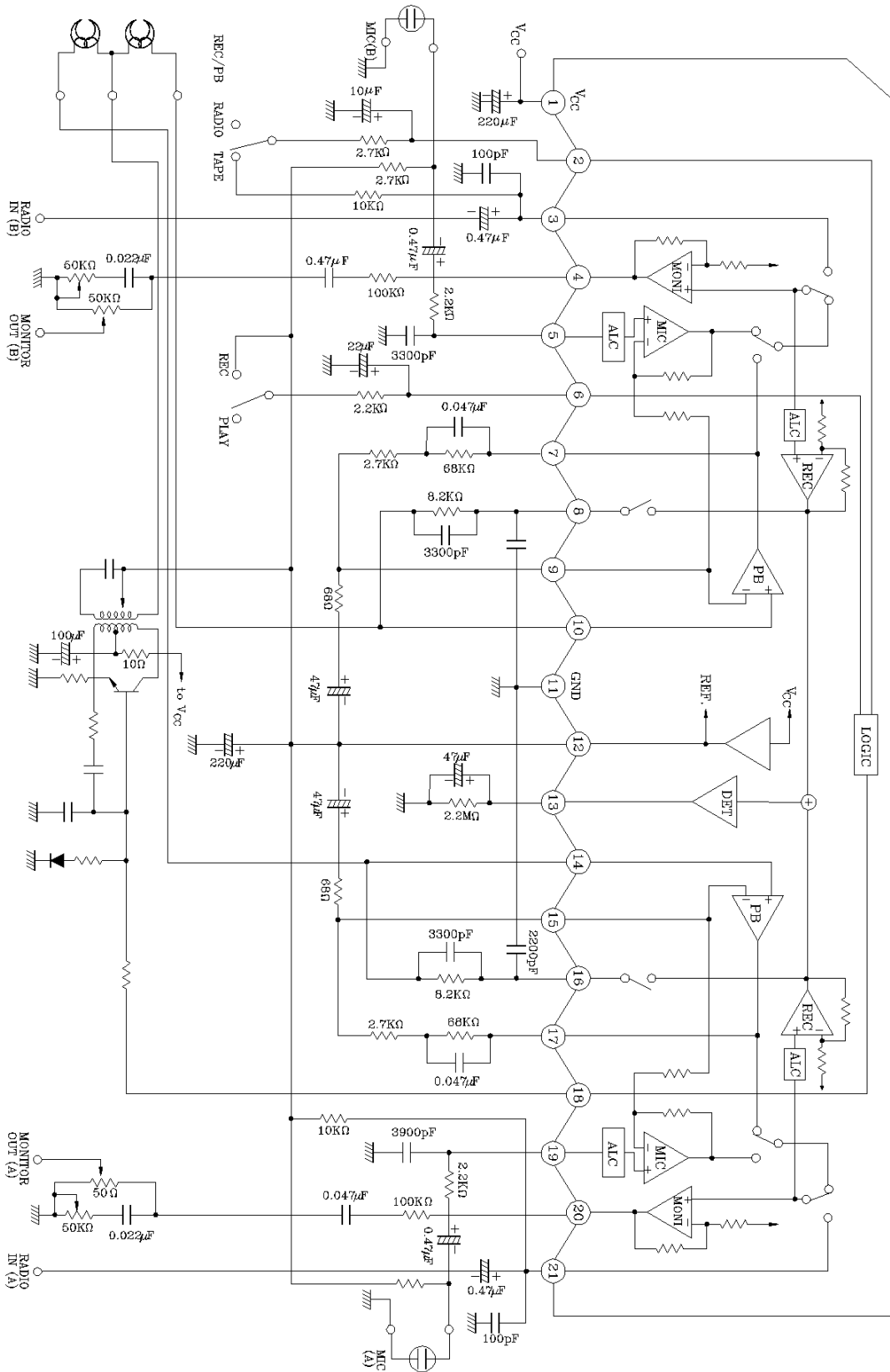

KIA7417AP

TEST METHOD (cf TEST CIRCUIT)

SYMBOL	S1	S2	S3	S4
I _{cc1}	RADIO	PLAY	a	DC
I _{cc2}	RADIO	REC	↓	↓
I _{cc3}	TAPE	PLAY		
I _{cc4}	TAPE	REC		
V _{ref}	-	-		
G _{v1}	RADIO	REC	a	DC
V _{o max1}	↓	↓	↓	↓
V _{no1}				
THD1				
CT1				
RR1				
G _{vo2}	TAPE	PALY	b	DC
G _{v2}	TAPE	PALY	a	DC
V _{o max2}	↓	↓	↓	↓
V _{no2}				
THD2				
CT2				
RR2	TAPE	PLAY	a	AC

SYMBOL	S1	S2	S3	S4
G _{v3}	RADIO	REC	a	DC
V _{no3}	↓	↓	↓	↓
THD3				
CT3				
RR3	RADIO	REC	a	AC
ALC31	RADIO	REC	a	DC
ALC32	↓	↓	↓	↓
ALC33				
G _{v4}	TAPE	REC	a	DC
V _{no4}	↓	↓	↓	↓
THD4				
CT4				
RR4	TAPE	REC	a	AC
ALC41	TAPE	REC	a	DC
ALC42	↓	↓	↓	↓
ALC43				

KIA7417AP

DESCRIPTION OF EACH TERMINAL

TERMINAL No.	TERMINAL NAME	FUNCTION	EQUIVALENT CIRCUIT
1	V _{CC}	V _{CC}	-
2	TAPE/RADIO SW	Change over switch for tape mode and radio mode. Tape Mode : Tape play MIC REC Radio Mode : Radio play Radio REC	
3/21	RADIO (AUX) IN	Radio or Aux. input	<p>to Pin 12(VREF)</p>
4/20	MONITOR OUT	Monitor Amp output	<p>to Pin 12</p>
5/19	MIC IN	MIC Amp input	<p>ALC → to Pin 12</p>

KIA7417AP

DESCRIPTION OF EACH TERMINAL

TERMINAL No.	TERMINAL NAME	FUNCTION	EQUIVALENT CIRCUIT
6	REC/PLAY SW	Change over switch for REC mode and play mode. REC Mode : MIC REC Radio REC Play Mode : Tape play Radio play	
7/17	TAPE OUT	Tape Play back Amp (PB AMP) output	
8/16	REC OUT	Recording Amp output	
9/15	PB NF	Tape play back Amp (PB AMP) NF	

KIA7417AP

DESCRIPTION OF EACH TERMINAL

TERMINAL No.	TERMINAL NAME	FUNCTION	EQUIVALENT CIRCUIT
10/14	TAPE IN	Tape play back Amp (PB AMP) input	
11	GND	GND	-
12	REFERENCE	Reference voltage terminal	
13	AGC T.C	Automatic level control (ALC) time constant terminal.	
18	Vstb	Recording bias circuit control signal output.	

KIA7417AP

OPERATION MODE BY EXTERNAL SWITCHES (S1, S2) COMBINATION

CIRCUIT BLOCK \ S2	S2=REC		S2=PLAY		
	S1	S1=RADIO	S1=TAPE	S1=RADIO	S1=TAPE
MIC AMP		ON	ON	OFF	OFF
PB AMP		OFF	OFF	ON	ON
REC AMP		ON	ON	OFF	OFF
MONITOR AMP		ON	OFF	ON	ON
S _{MP}		M	M	P	P
S _{TR}		R	T	R	T
S _{RE}		ON	ON	OFF	OFF
OPERATION MODE		RADIO RECORDING	MIC RECORDING	RADIO PLAY	TAPE PLAY BACK

CONTROL SWITCH TERMINAL (2, 6pin) THRESHOLD VOLTAGE

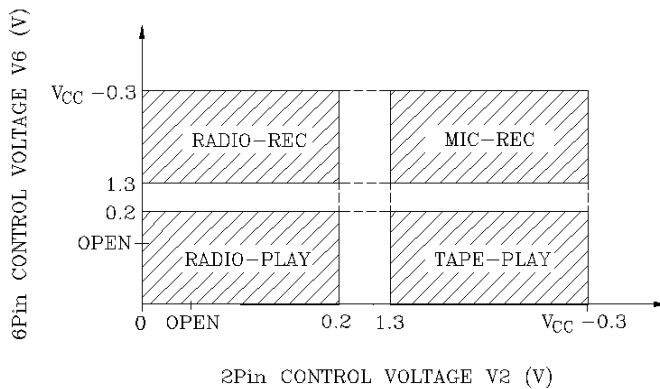

KIA7417AP

OPERATION IN EACH MODE

(1) RADIO-REC MODE

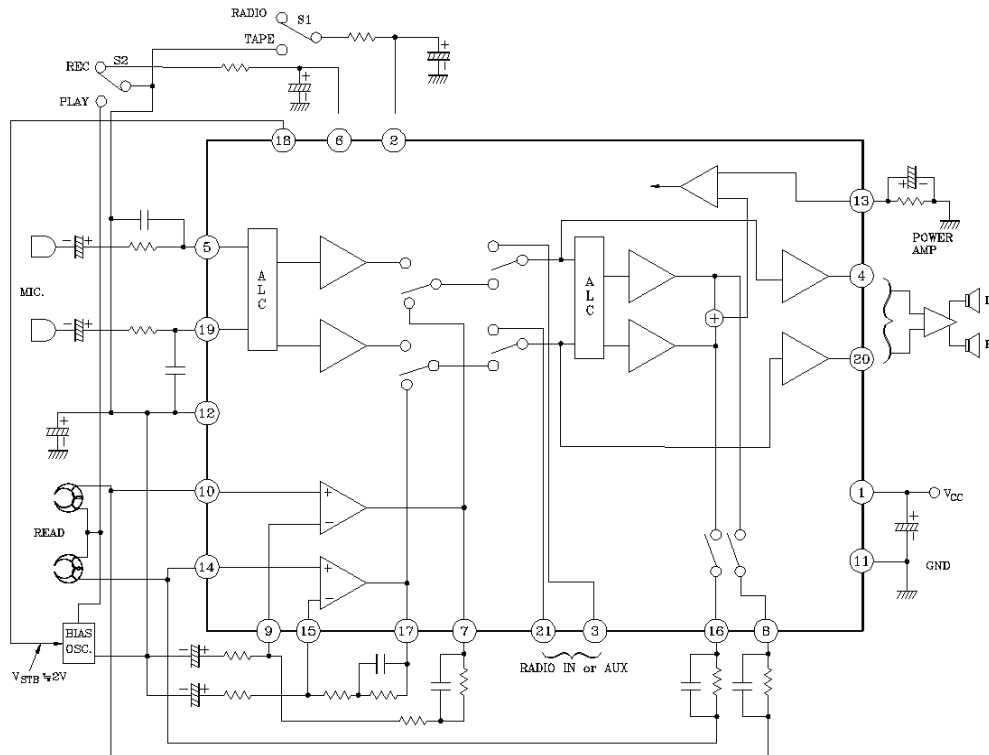

(2) RADIO-PLAY MODE

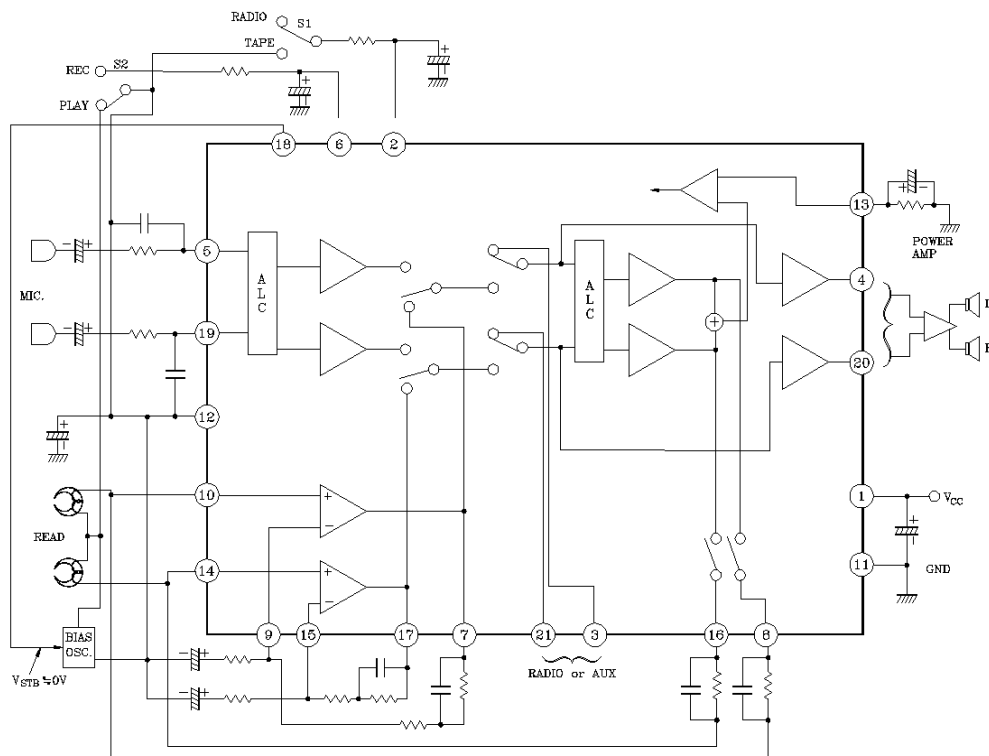

KIA7417AP

(3) MIC-REC MODE

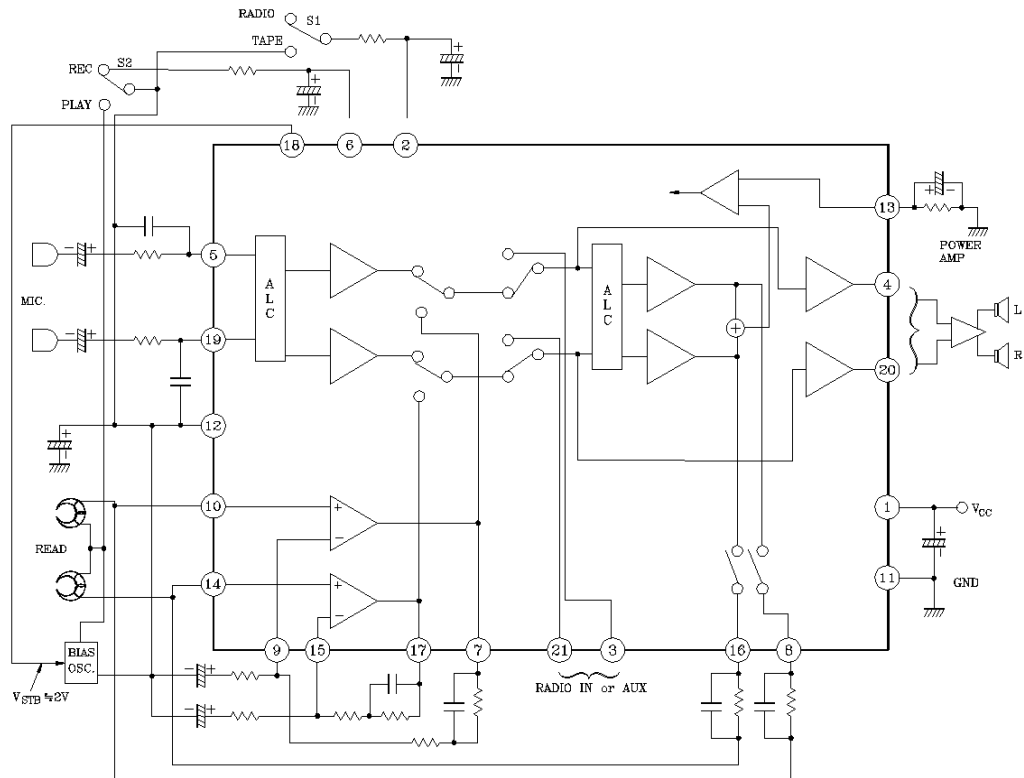

(4) TAPE-PLAY MODE

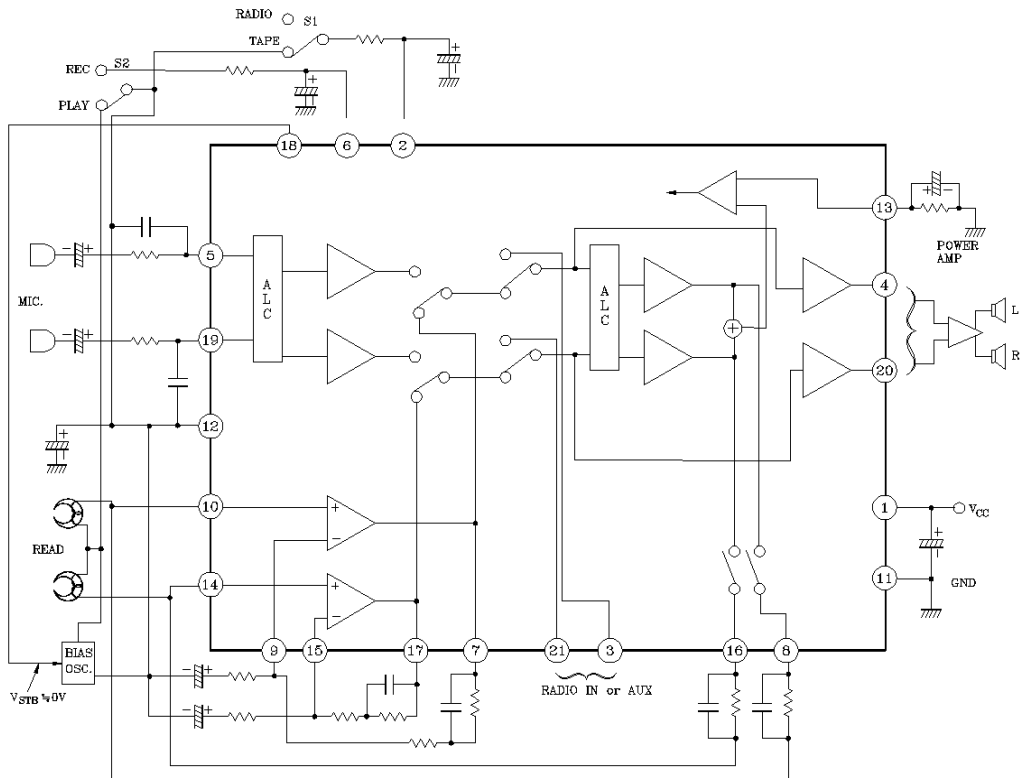

KIA7417AP

DESCRIPTION OF BIAS OSC. CONTROL TERMINAL (18pin).

The equivalent circuit of 18 pin is shown in Fig. 1.

When this IC is in the REC MODE (RADIO REC or MIC REC), the switch Sa is in the "ON" state and the DC voltage 2.05V (Typ.) appears in this terminal. The output current value of this terminal should be under $300\mu\text{A}$.

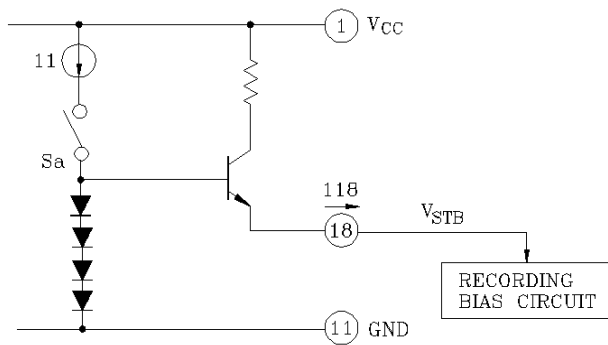
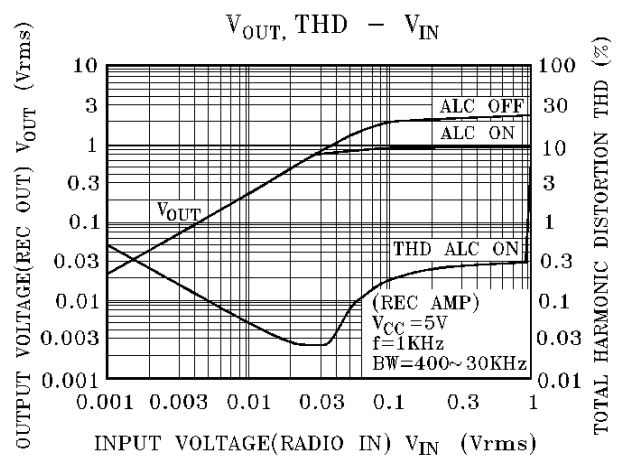
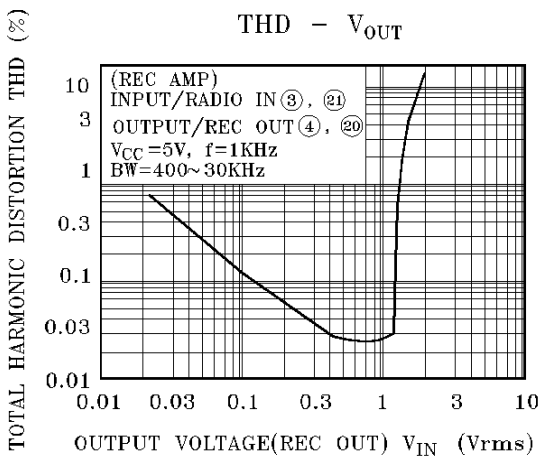
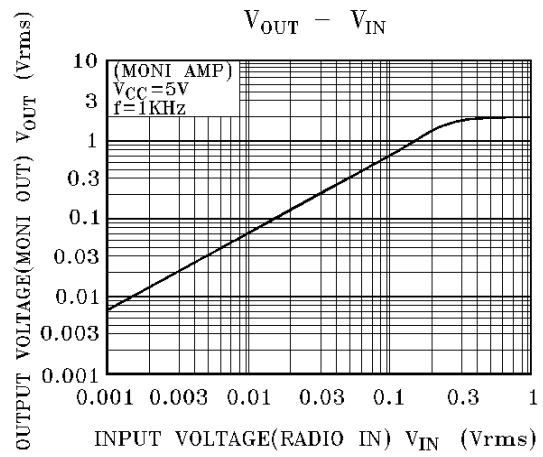
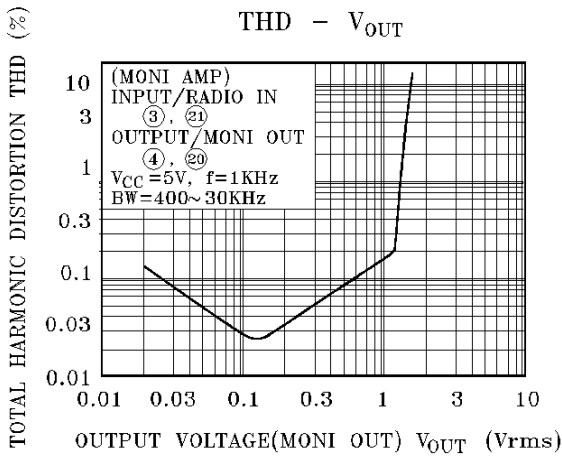
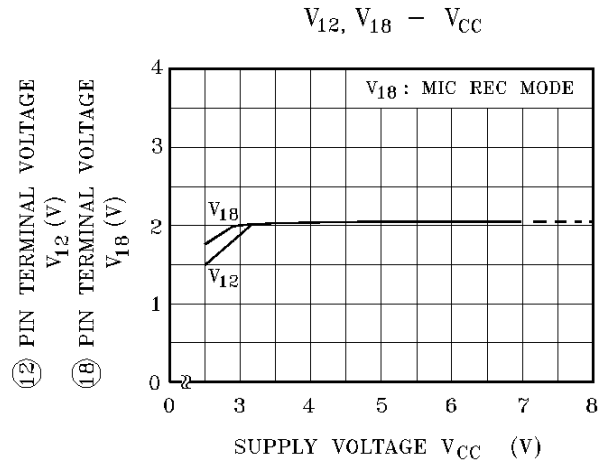
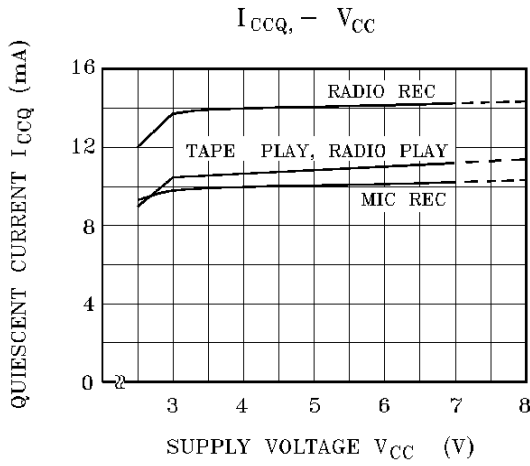
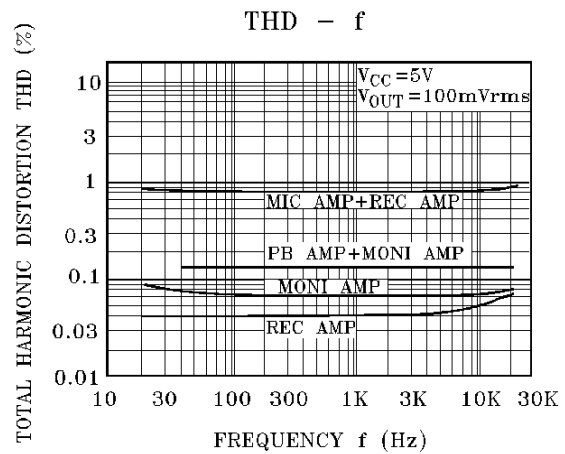
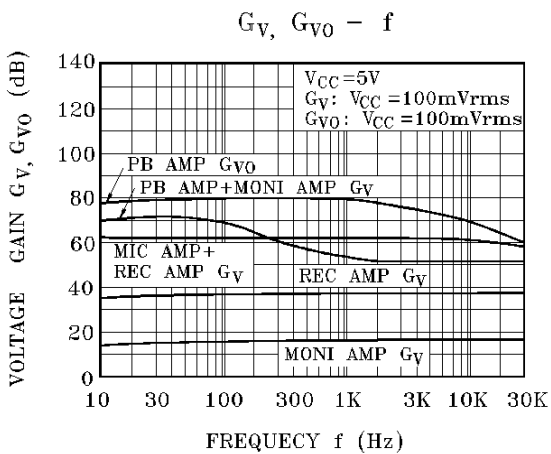
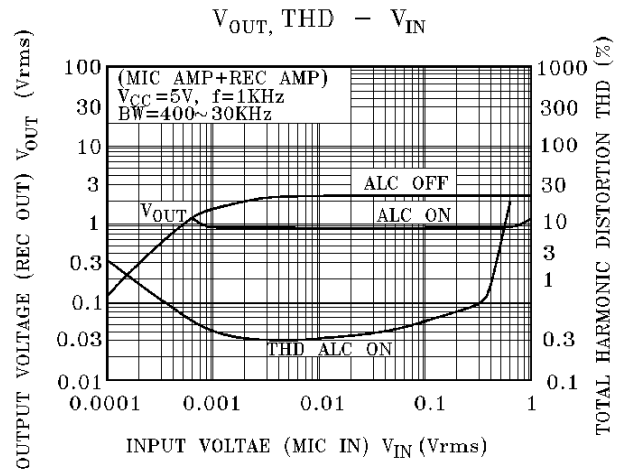
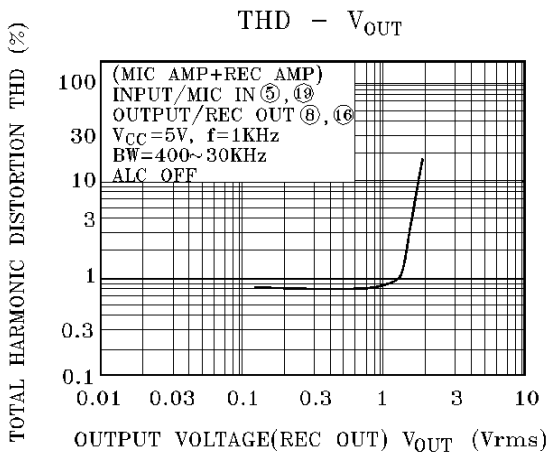
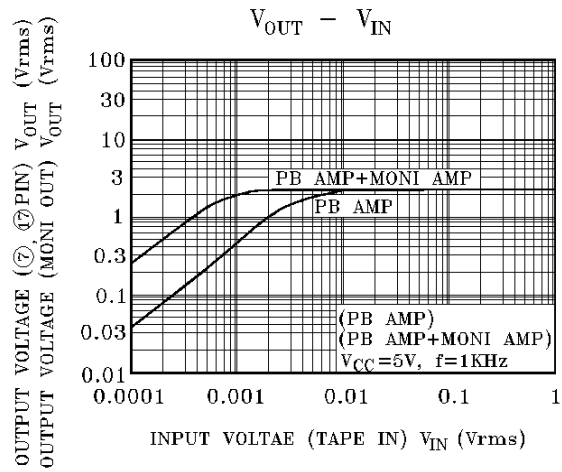
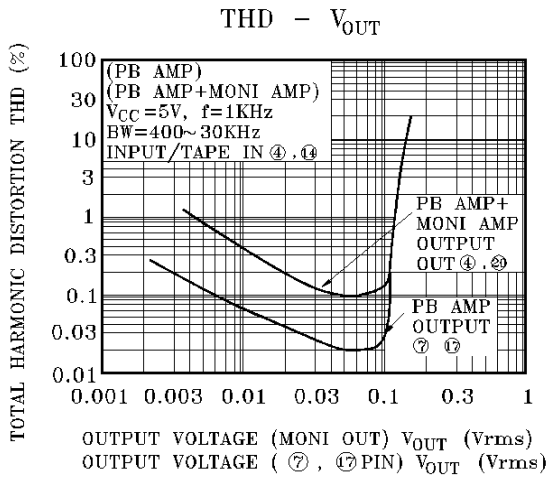

Fig. 1

KIA7417AP



KIA7417AP



KIA7417AP

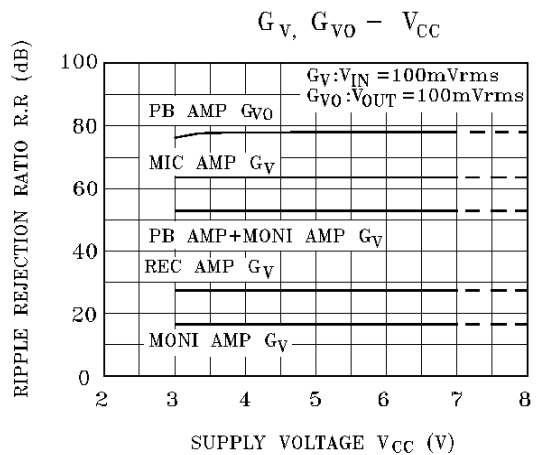
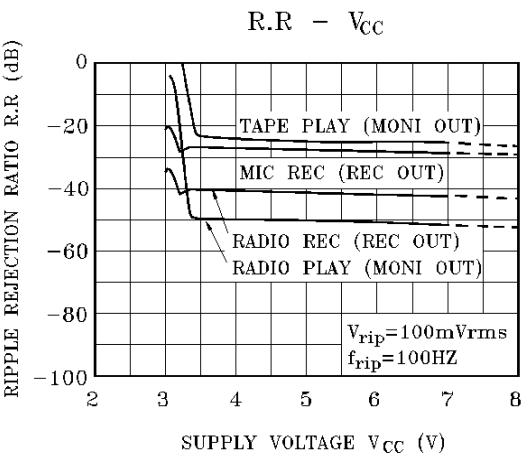
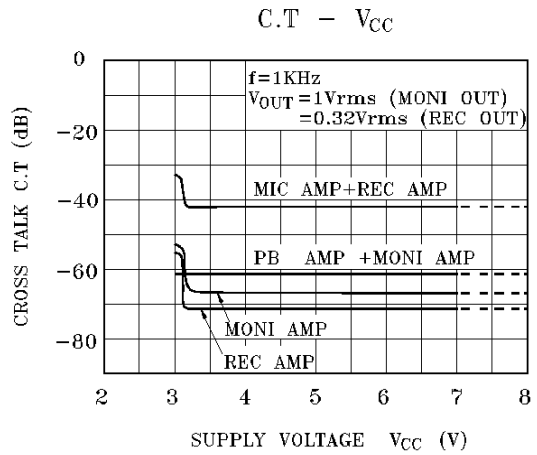
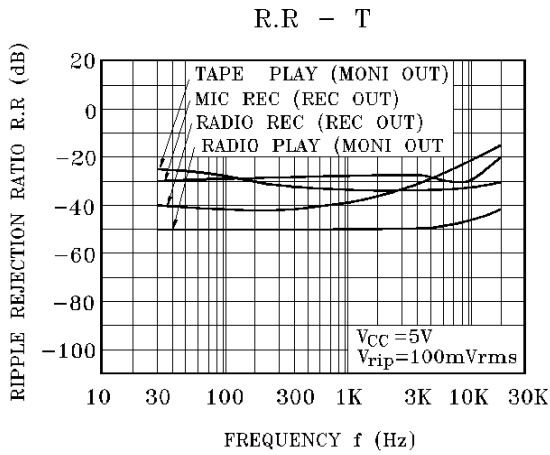
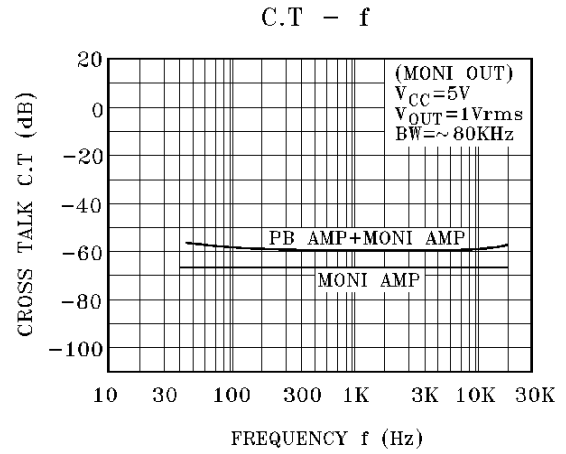
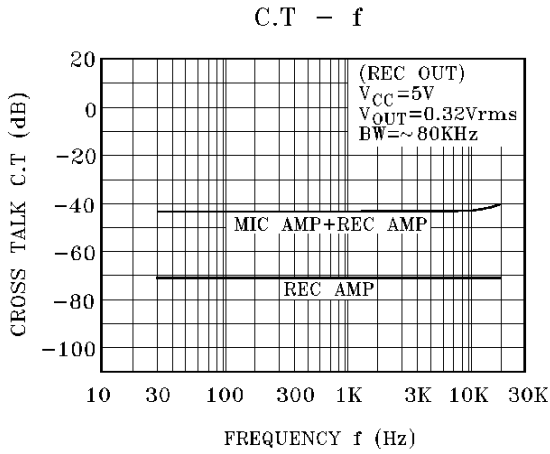

KIA7417AP

