

5 TERMINAL LOW DROPOUT VOLTAGE REGULATOR

The KIA78R × × series are Low Dropout Voltage Regulator suitable for various electronic equipments. It provides constant voltage power source with DPAK-5 terminal surface mount type PKG.

The Regulator has multi function such as over current protection, overheat protection and ON/OFF control.

FEATURES

- 1.0A Output Low Dropout Voltage Regulator.
- Built in ON/OFF Control Terminal.
- Built in Over Current Protection, Over Heat Protection Function.

LINE UP

ITEM	OUTPUT VOLTAGE (Typ.)	UNIT
KIA78R05F	5	V
KIA78R06F	6	
KIA78R08F	8	
KIA78R09F	9	
KIA78R10F	10	
KIA78R12F	12	
KIA78R15F	15	
KIA78R25F	2.5	
KIA78R33F	3.3	
KIA78R35F	3.5	

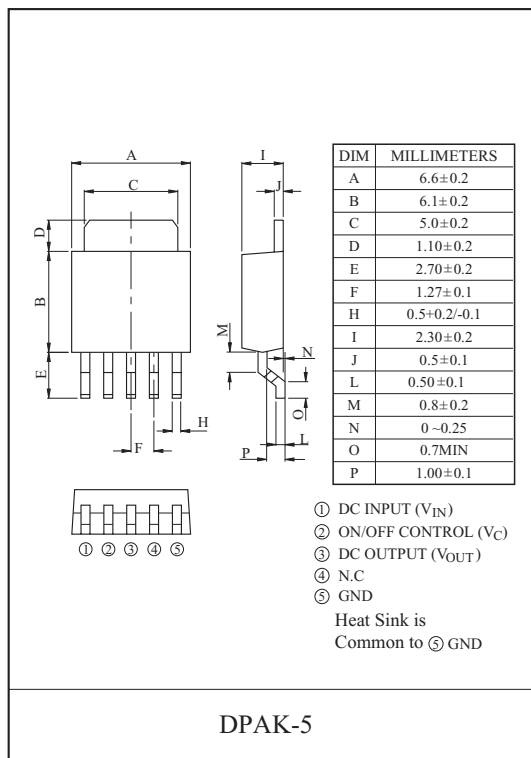

MAXIMUM RATINGS (Ta=25 °C)

CHARACTERISTIC	SYMBOL	RATING	UNIT	REMARK
Input Voltage	V _{IN}	35	V	-
ON/OFF Control Voltage	V _C	35	V	-
Output Current	I _O	1	A	-
Power Dissipation 1	P _{D1}	1.3	W	No Heatsink
Power Dissipation 2	P _{D2}	13	W	Infinite Heatsink
Junction Temperature	T _j	150	°C	-
Operating Temperature	T _{opr}	-20~80	°C	-
Storage Temperature	T _{stg}	-30~150	°C	-
Soldering Temperature (10sec)	T _{sol}	260	°C	-

KIA78R05F~KIA78R35F

ELECTRICAL CHARACTERISTICS

(Unless otherwise specified, $I_O=0.5A$, $T_a=25^\circ C$, Note1.)

CHARACTERISTIC		SYMBOL	CONDITIONS	MIN.	TYP.	MAX.	UNIT
Output Voltage	KIA78R05F	V_O	-	4.88	5.0	5.12	V
	KIA78R06F		-	5.85	6.0	6.15	
	KIA78R08F		-	7.80	8.0	8.2	
	KIA78R09F		-	8.78	9.0	9.22	
	KIA78R10F		-	9.75	10.0	10.25	
	KIA78R12F		-	11.70	12.0	12.30	
	KIA78R15F		-	14.70	15.0	15.30	
	KIA78R25F		-	2.438	2.50	2.562	
	KIA78R33F		-	3.220	3.30	3.380	
	KIA78R35F		-	3.413	3.50	3.587	
Load Regulation		Reg Load	$5mA \leq I_{OUT} \leq 1A$	-	0.1	2.0	%
Line Regulation		Reg Line	(Note 2)	-	0.5	2.5	%
Temperature Coefficient of Output Voltage		$T_C V_O$	$T_j=0 \sim 125^\circ C$	-	± 0.02	± 0.05	%/ $^\circ C$
Ripple Rejection		$R \cdot R$	-	45	55	-	dB
Drop Out Voltage		V_D	$I_O=1A, V_{IN}=0.95 V_{OUT}$	-	-	0.5	V
Output ON state for control Voltage		$V_{C(ON)}$	-	2.0	-	-	V
Output ON state for control Current		$I_{C(ON)}$	$V_C=2.7V$	-	-	20	μA
Output OFF state for control Voltage		$V_{C(OFF)}$	-	-	-	0.8	V
Output OFF state for control Current		$I_{C(OFF)}$	$V_C=0.4V$	-	-	-0.4	mA
Quiescent Current		I_Q	$I_O=0$	-	-	10	mA

Note1) V_{IN} of KIA78R05=7V

- " KIA78R06=8V
- " KIA78R08=10V
- " KIA78R09=15V
- " KIA78R10=16V
- " KIA78R12=18V
- " KIA78R15=21V
- " KIA78R25=4.2V
- " KIA78R33=5.0V
- " KIA78R35=5.2V

Note2) V_{IN} of KIA78R05=6~12V

- " KIA78R06=7~15V
- " KIA78R08=9~25V
- " KIA78R09=10~25V
- " KIA78R10=11~26V
- " KIA78R12=13~29V
- " KIA78R15=16~32V
- " KIA78R25=3.2~10V
- " KIA78R33=4.0~10V
- " KIA78R35=4.2~10V

KIA78R05F~KIA78R35F

BLOCK DIAGRAM

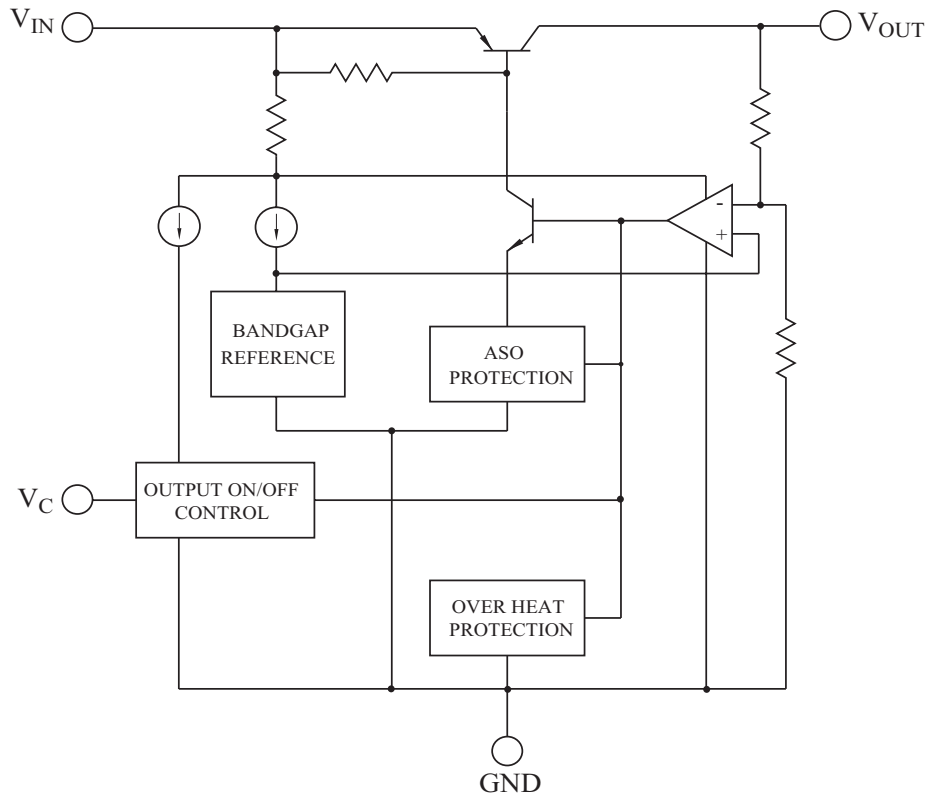

KIA78R05F~KIA78R35F

Fig. 1 Standard Test Circuit

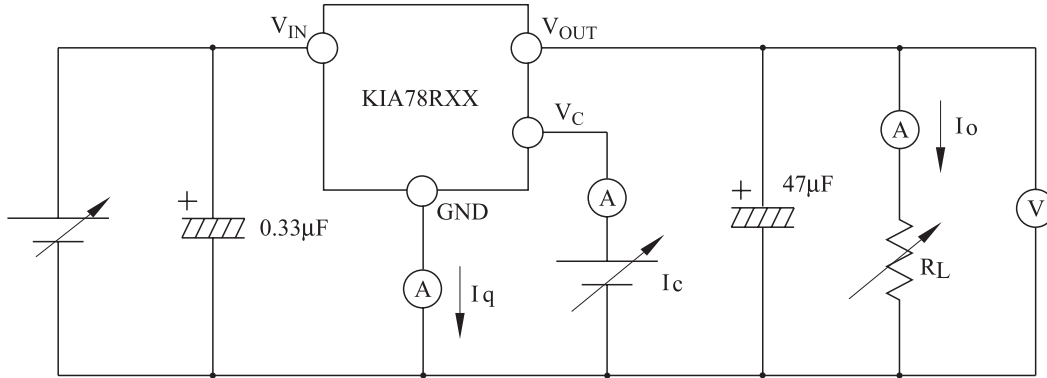

Fig. 2 Ripple Rejection Test Circuit

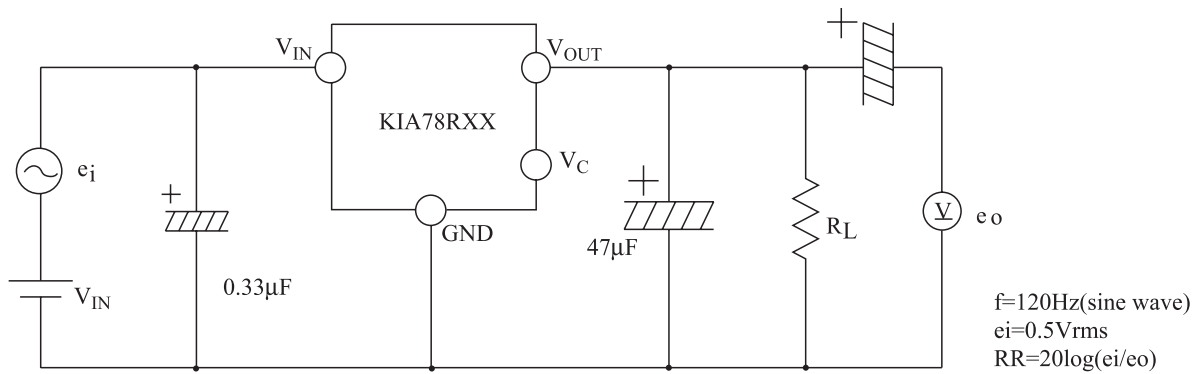
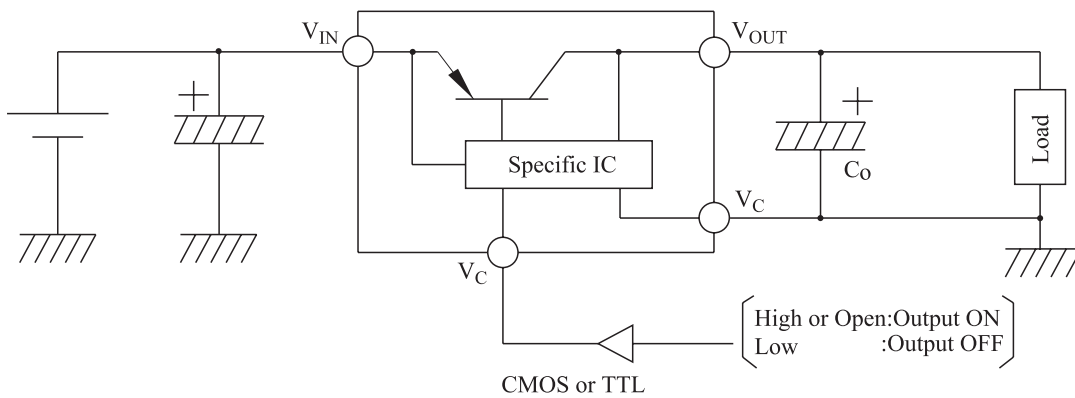

Fig. 3 Application Circuit for Standard



KIA78R05F~KIA78R35F

Fig. 4 $P_D - T_a$ (DPAK-5)

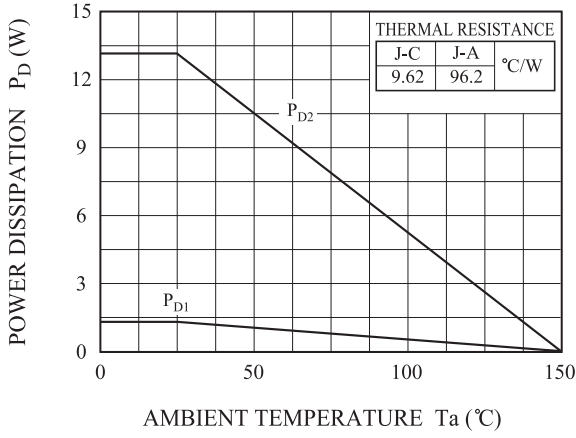

Fig. 5 $V_{OUT} - I_{OUT}$

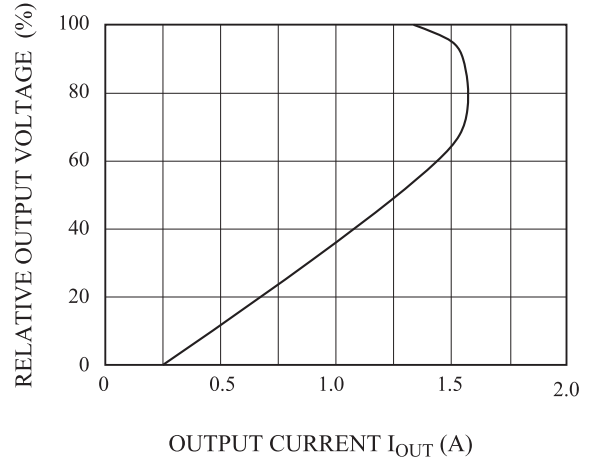

Fig. 6 $\Delta V_O - T_j$

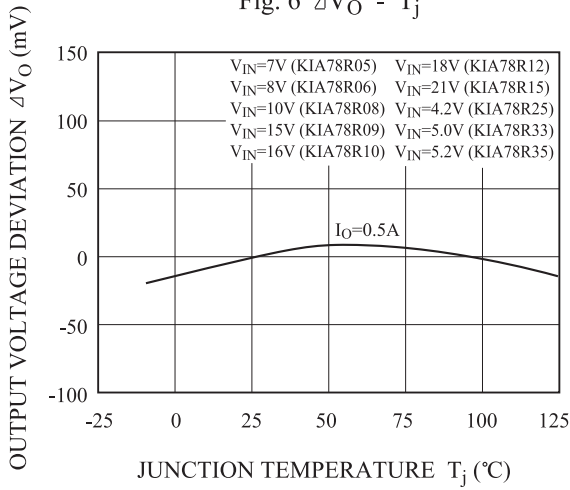

Fig. 7 $V_D - T_j$

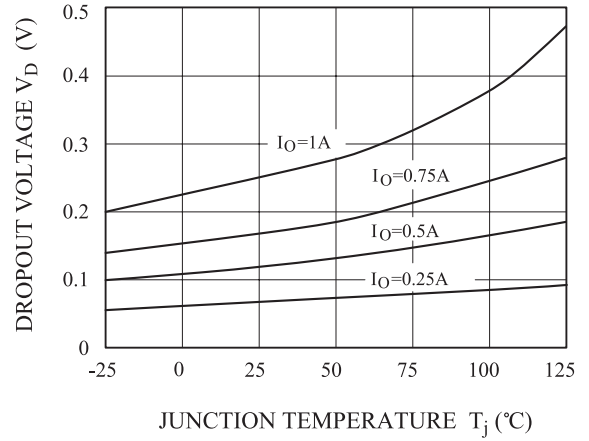

Fig. 8 $I_q - T_j$

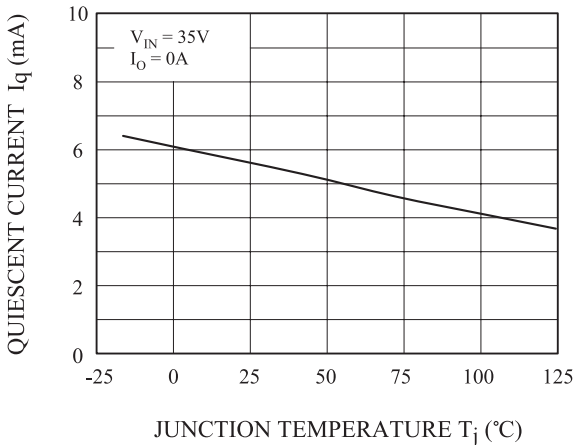
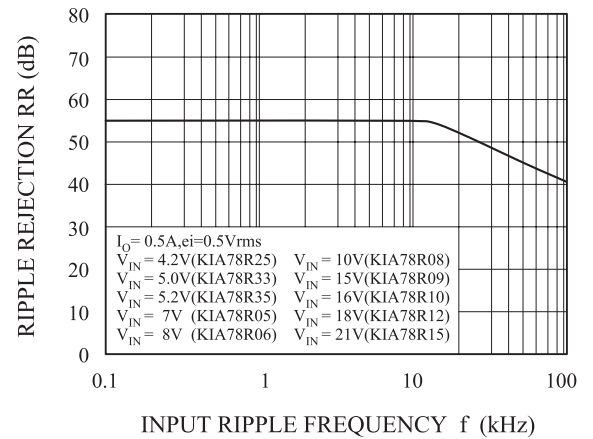

Fig. 9 R.R. - f



KIA78R05F~KIA78R35F

Fig. 10 R.R - I_{OUT}

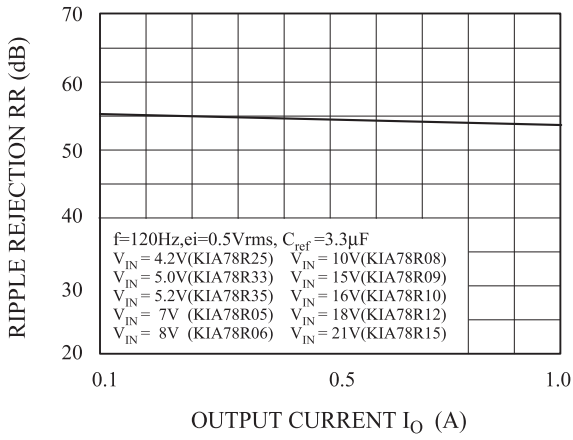

Fig. 11 V_{OUT} - V_{IN} (KIA78R05)

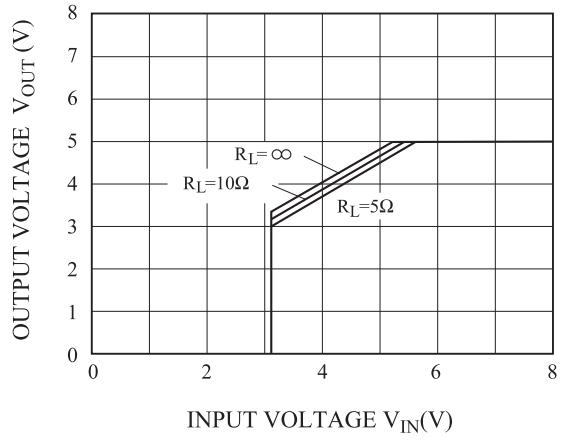

Fig. 12 V_{OUT} - V_{IN} (KIA78R06)

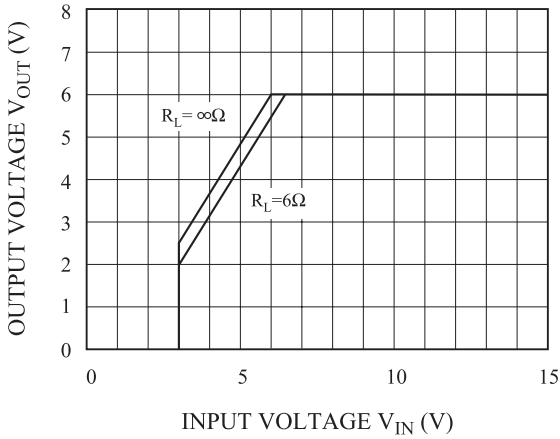

Fig. 13 V_{OUT} - V_{IN} (KIA78R08)

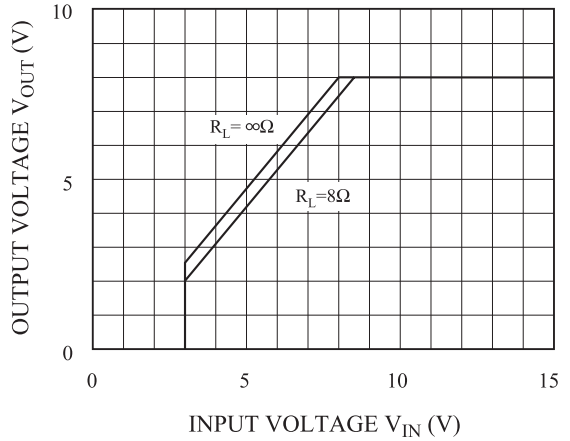

Fig. 14 V_{OUT} - V_{IN} (KIA78R09)

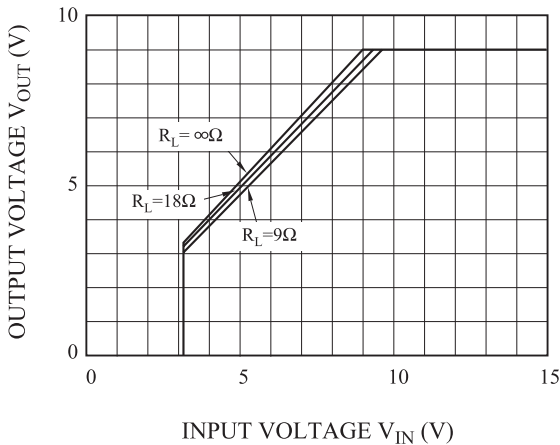
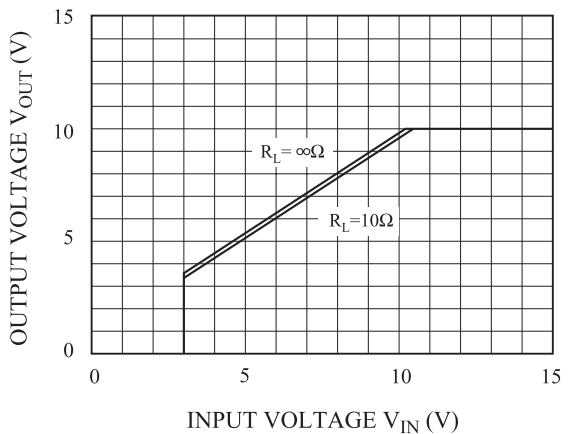

Fig. 15 V_{OUT} - V_{IN} (KIA78R10)



KIA78R05F~KIA78R35F

Fig. 16 $V_{OUT} - V_{IN}$ (KIA78R12)

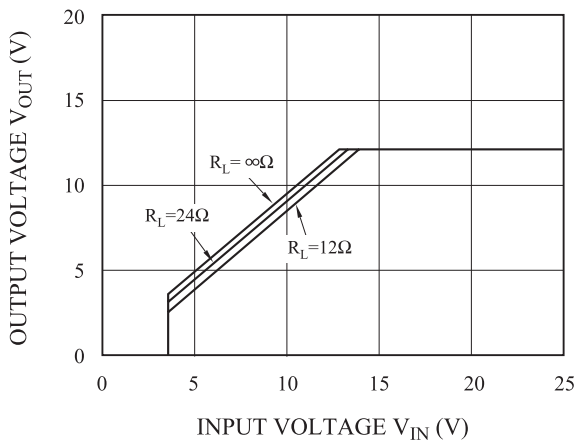

Fig. 17 $V_{OUT} - V_{IN}$ (KIA78R15)

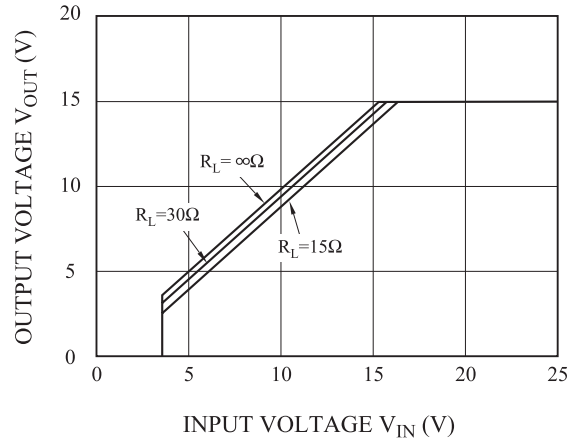

Fig. 18 $I_{BIAS} - V_{IN}$ (KIA78R05)

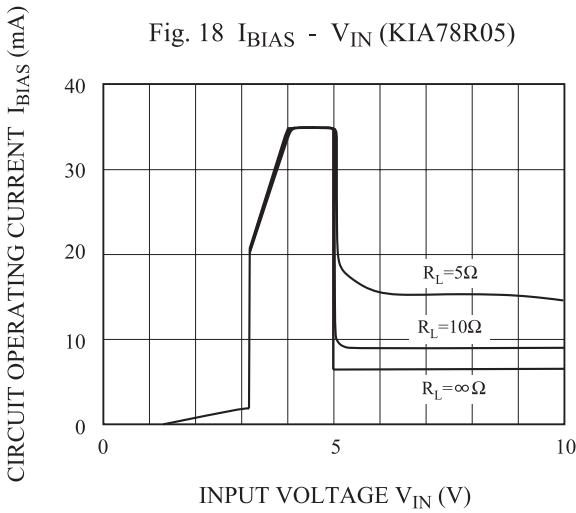

Fig. 19 $I_{BIAS} - V_{IN}$ (KIA78R06)

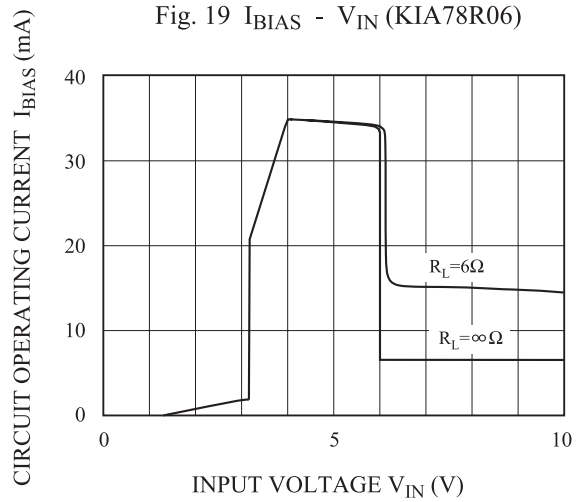

Fig. 20 $I_{BIAS} - V_{IN}$ (KIA78R08)

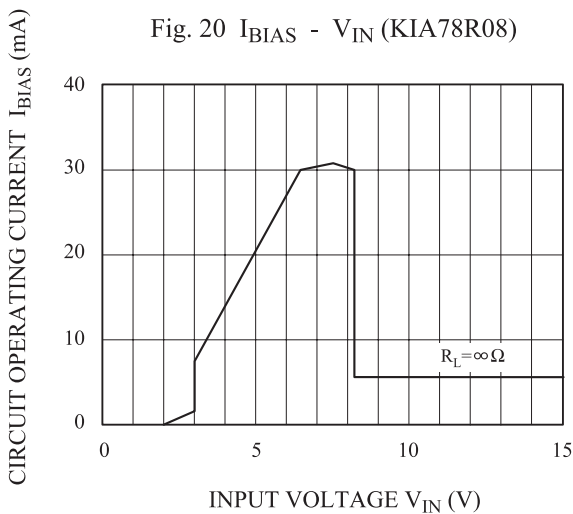
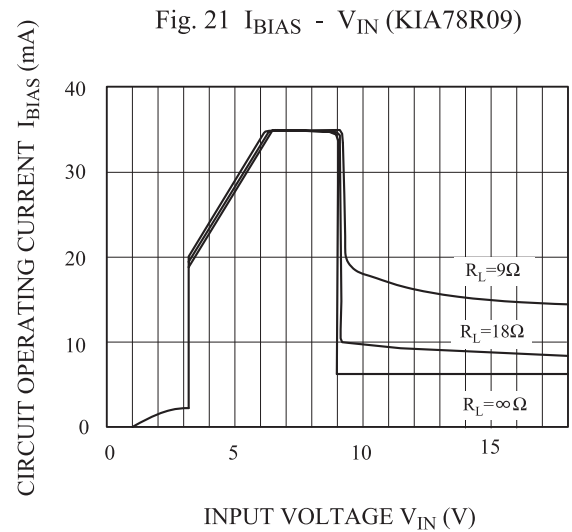

Fig. 21 $I_{BIAS} - V_{IN}$ (KIA78R09)



KIA78R05F~KIA78R35F

Fig. 22 $I_{BIAS} - V_{IN}$ (KIA78R10)

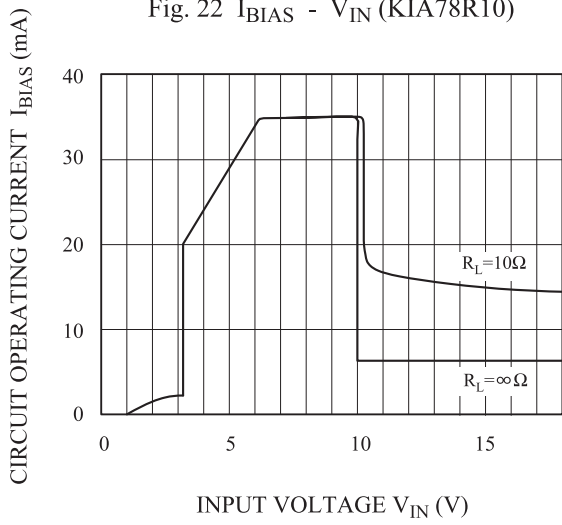

Fig. 23 $I_{BIAS} - V_{IN}$ (KIA78R12)

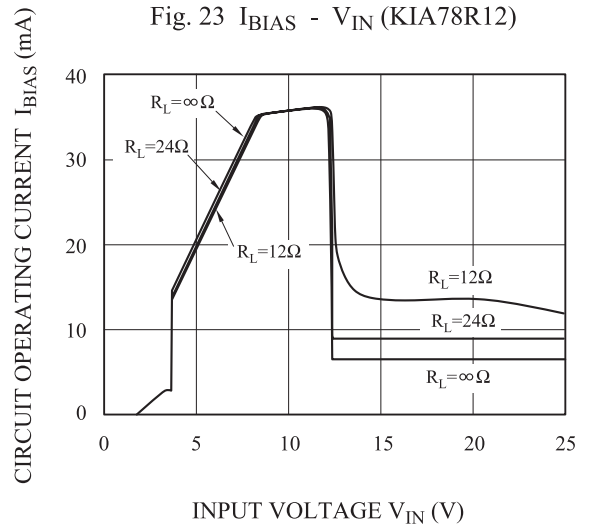

Fig. 24 $I_{BIAS} - V_{IN}$ (KIA78R15)

