

5V VOLTAGE REGULATOR WITH WATCHDOG TIMER

The KIA8000S is an IC specially designed for automotive microcomputer systems. It produces an output voltage of $5 \pm 0.25V$ without need for adjustment from its accurate reference voltage and amplifier circuit. At power-on, it outputs a reset signal to reset the system. It will also output a reset signal when the 5V output voltage drops below 85% because of external disturbance or other problem. It also incorporates a watchdog timer for self-diagnosing the system. When the system malfunctions, the IC generates reset pulses intermittently to prevent the system from running away.

FEATURES

- Accurate output : $5 \pm 0.25V$.
- Output voltage adjusting pin attached.
- Power-on reset timer incorporated.
- Watchdog timer incorporated.
- Wide operating voltage range : 40V (Max.).
- Wide operating temperature range : from $-40 \sim 85^\circ C$.
- Load dump protection : 80V (Max.) (1 second).
- Small SIP-9 pin.

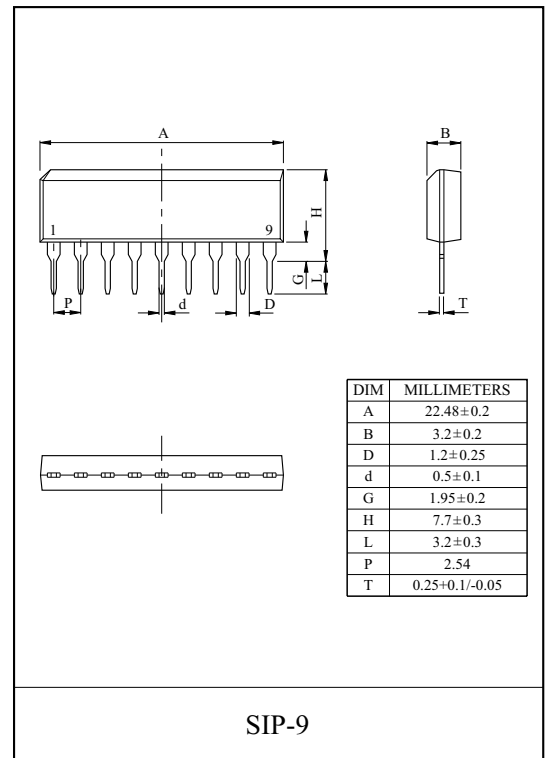

BLOCK DIAGRAM AND PIN ASSIGNMENT

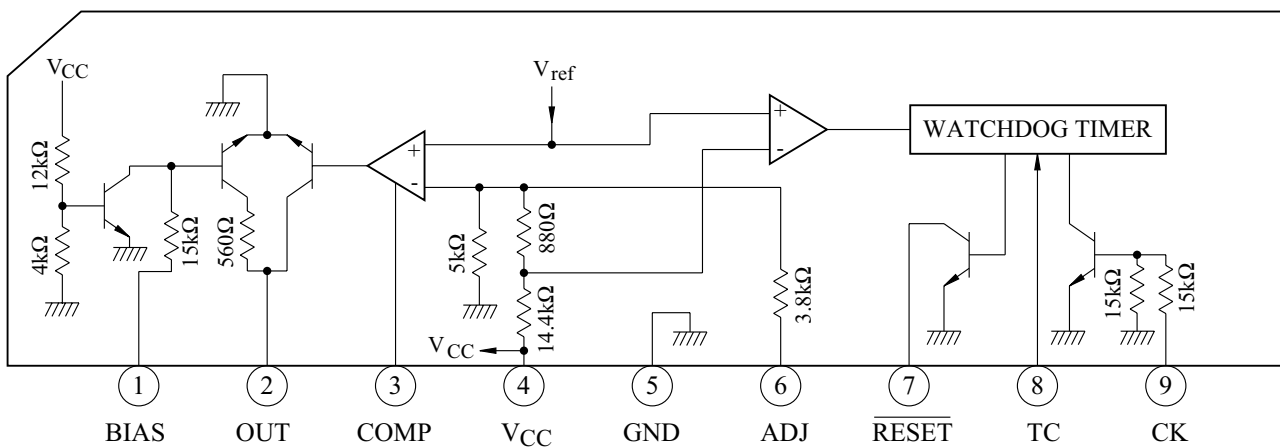

KIA8000S

TIMING CHART

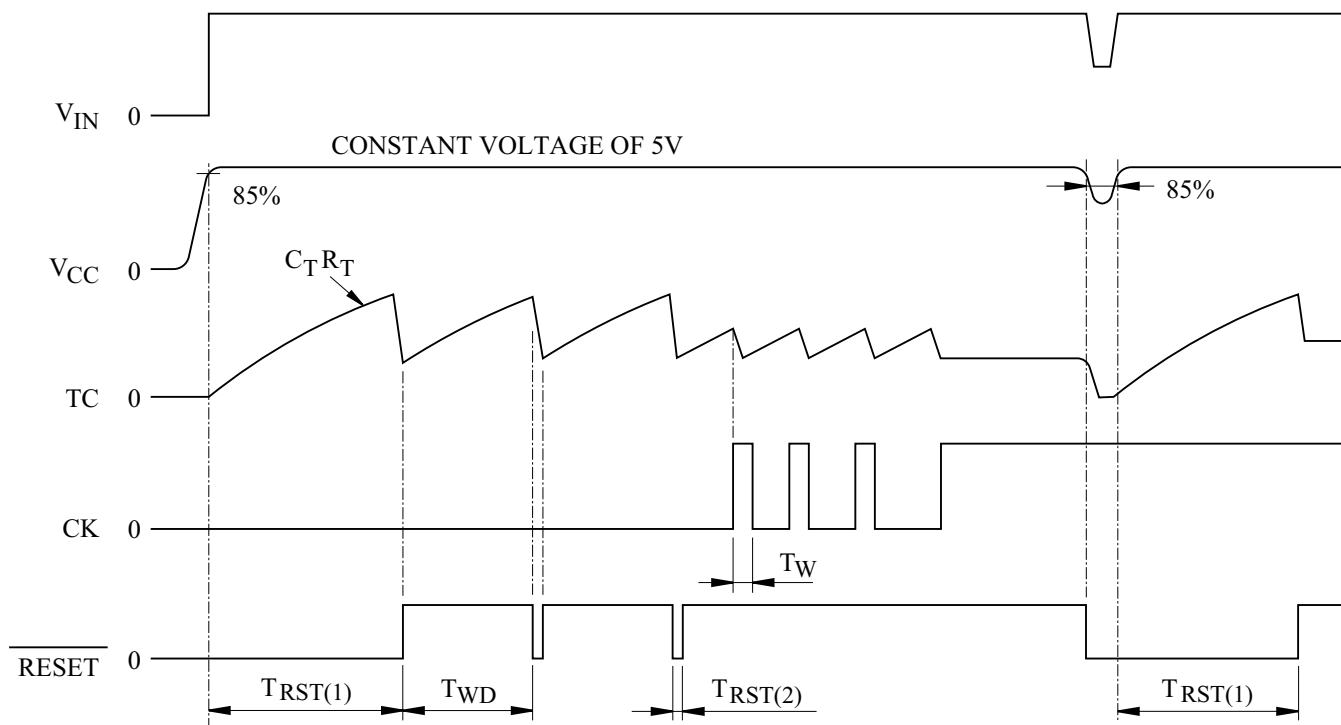

MAXIMUM RATINGS ($T_a=25^\circ\text{C}$)

CHARACTERISTIC	SYMBOL	RATING	UNIT
Input Voltage	V_{IN1}	80 (1s)	V
	V_{IN2}	-5 ~ +16	
Output Current	I_{OUT1}	10	mA
	I_{OUT2}	4	
Output Voltage	V_{OUT1}	80 (1s)	V
	V_{OUT2}	16	
Power Dissipation	P_D	500	mW
Operating Temperature	T_{opr}	-40 ~ 85	$^\circ\text{C}$
Storage Temperature	T_{stg}	-55 ~ 150	$^\circ\text{C}$
Lead Temperature-time	T_{so1}	260 (10 s)	$^\circ\text{C}$

Note) V_{IN1} : BIAS Input

V_{IN2} : CK Input

I_{OUT1} , V_{OUT1} : OUT Output

I_{OUT2} , V_{OUT2} : $\overline{\text{RESET}}$ Output

KIA8000S

ELECTRICAL CHARACTERISTICS ($V_{IN}=6 \sim 17V$, $T_a=-40 \sim 85^\circ C$)

CHARACTERISTIC	SYMBOL	PIN	TEST CIRCUIT	TEST CONDITION	MIN.	TYP.	MAX.	UNIT	
Output Voltage	V_{REG}	V_{CC}	1	-	4.75	5.0	5.25	V	
Line Regulation	-	V_{CC}	-	$V_{IN}=6 \sim 40V$	-	0.1	0.5	%	
Load Regulation	-	V_{CC}	-	$I_{LOAD}=1 \sim 50mA$	-	0.1	0.5	%	
Temperature Coefficient	-	V_{CC}	-	-	-	0.01	-	%/ $^\circ C$	
Output Voltage	V_{OL}	\overline{RESET}	2	$I_{OL}=2mA$	-	-	0.5	V	
Output Leakage Current	I_{LEAK}	\overline{RESET}	3	$V_{OUT}=10V$	-	-	5	μA	
Input Current	I_{IN}	TC	4	$V_{IN}=0 \sim 3.5V$	-3	-	3	μA	
Threshold Voltage	V_{IH}	TC	5	\overline{RESET} "High" to "Low"	-	$80\% \times V_{REG}$	-	V	
	V_{IL}			\overline{RESET} "Low" to "High"	-	$40\% \times V_{REG}$	-		
Input Current	I_{IN}	CK	6	$V_{IN}=5V$	-	0.3	0.7	mA	
Input Voltage	V_{IH}	CK	5	-	2	-	-	V	
	V_{IL}			-	-	0.5			
Reset Detecting Voltage	-	V_{CC}	-	-	$82\% \times V_{REG}$	$85\% \times V_{REG}$	$88\% \times V_{REG}$	V	
Standby Current	I_S	V_{CC}	8	$V_{IN}=14V$	-	5	6.5	mA	
WatchDog Timer	T_{WD}	\overline{RESET}	7	-	$0.9 \times C_T R_T$	$1.1 \times C_T R_T$	$1.3 \times C_T R_T$	-	
Reset Timer	1	$T_{RST(1)}$	\overline{RESET}	7	-	$1.3 \times C_T R_T$	$1.6 \times C_T R_T$	$1.9 \times C_T R_T$	-
	2	$T_{RST(2)}$	\overline{RESET}	7	-	$150 \times C_T$	$300 \times C_T$	$600 \times C_T$	-
Clock Pulse Width	T_W	CK	-	-	3	-	-	μS	

Note) Reset timer (1) : Power-on reset time.

Reset timer (2) : Watchdog reset time.

KIA8000S

DESCRIPTION OF PIN

PIN No.	SYMBOL	DESCRIPTION
1	BIAS	Used to start power supply. The starting current is supplied through a resistor by the input voltage. The output current from this starting current is as follows : $I_{OUT(2PIN)} \geq 30 \times (V_{IN}-0.7)/(15+R_1) \text{ (mA)}$ $R_1 : \text{Resistor (k } \Omega \text{) installed outside pin 1.}$ This current, if V_{CC} exceeds 2.7V, is absorbed by the internal circuit, and I_{OUT} is supplied by V_{CC} .
2	OUT	The base of a PNP transistor mounted outside is connected to this pin, which stabilizes output voltage. Therefore, power supply can be designed in accordance with load capacity. Since the recommended current of I_{OUT} is 5mA, an output current of 300mA can be obtained so long as h_{FE} of the transistor mounted outside is 60.
3	COMP	Phase compensation pin used to stabilize output.
4	Vcc	Supplies power to the internal circuit and also detects output Voltage.
5	GND	Ground pin.
6	ADJ	Output voltage adjusting pin. Voltage can be increased with a resistor inserted between pins ADJ and GND, and decreased with a resistor inserted between pins ADJ and V_{CC} . The maximum variable voltage is ± 1 volt.
7	<u>RESET</u>	Open collector output of an NPN transistor (1) The pin goes low if output voltage is 85% or less of normal output voltage. (2) The pin generates a reset signal that is determined by CR of pin TC. (3) If no clock pulse is input to the input of pin CK, reset pulses are intermittently generated. This function can be used as a watch dog timer for the microcomputer system.
8	TC	Used to set the reset timer and the watch dog timer.
9	CK	Input pin for the watch dog timer. The pin should be pulled up to V_{CC} if it is used only for the power-on reset timer.

KIA8000S

TEST CIRCUIT

1. V_{REG}

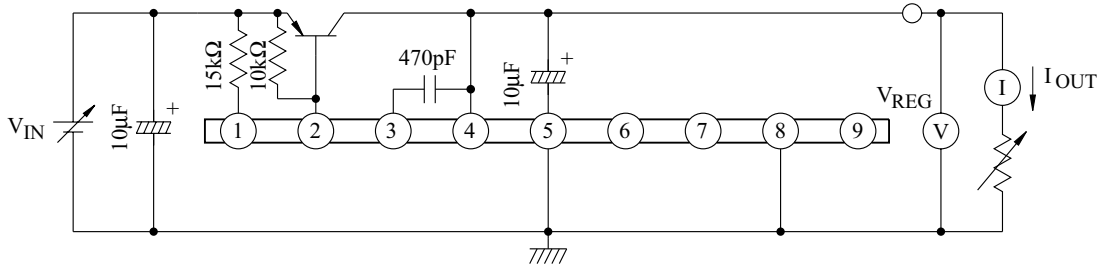

2. $V_{OL(RESET)}$

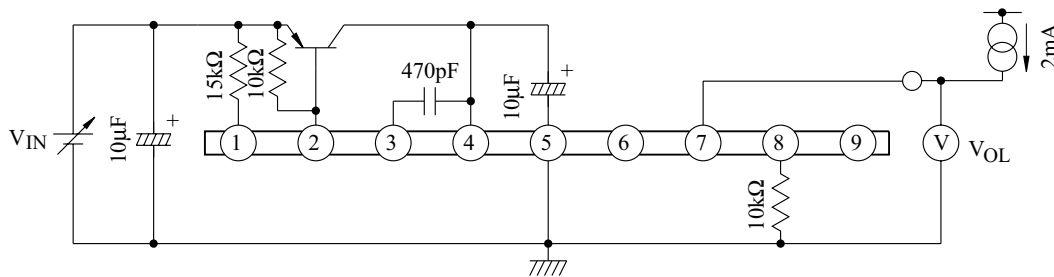

3. $I_{LEAK(RESET)}$

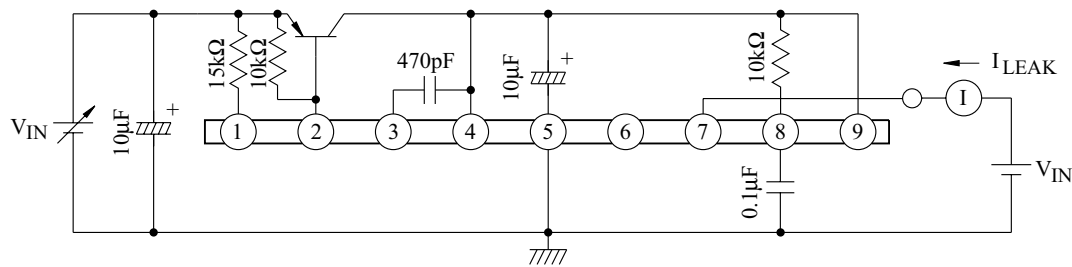

4. $I_{IN(TC)}$

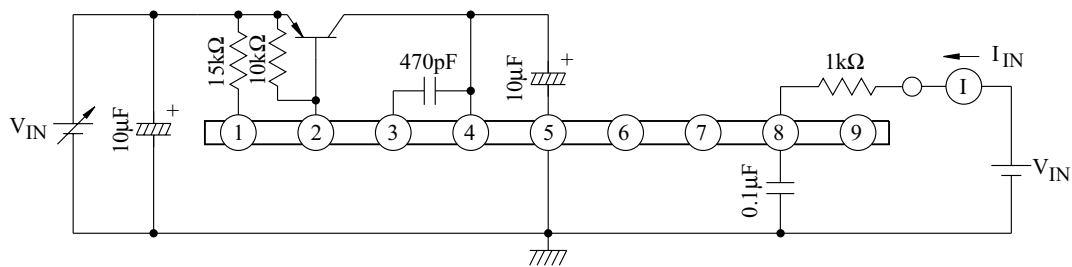

5. V_{IH} , $V_{IL(TC)}$, V_{IH} , $V_{IL(CK)}$

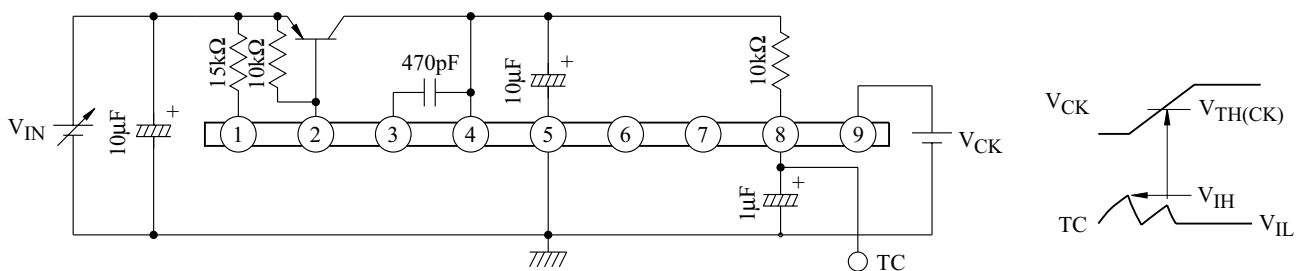

KIA8000S

TEST CIRCUIT

6. $I_{IN(CK)}$

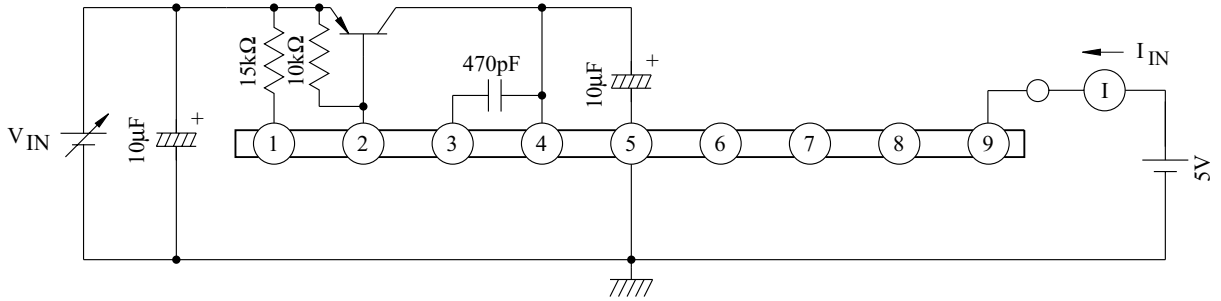

7. V_{RESET} , T_{WD} , $T_{RST(1)}$, $T_{RST(2)}$

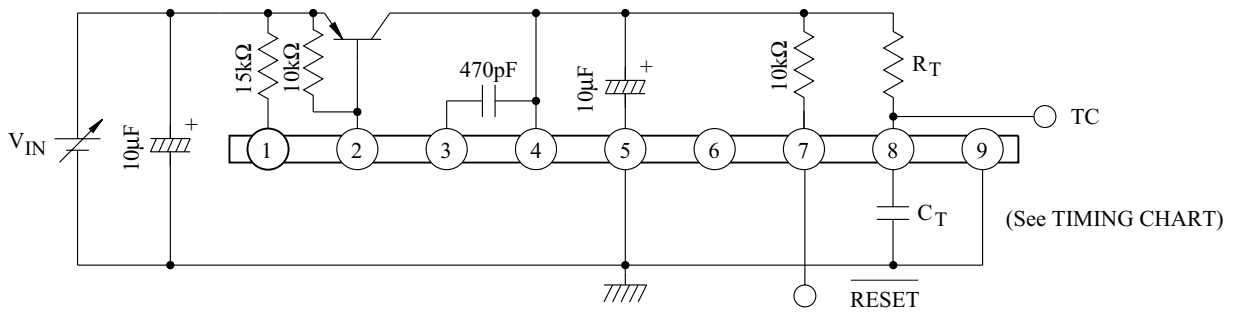

8. I_S

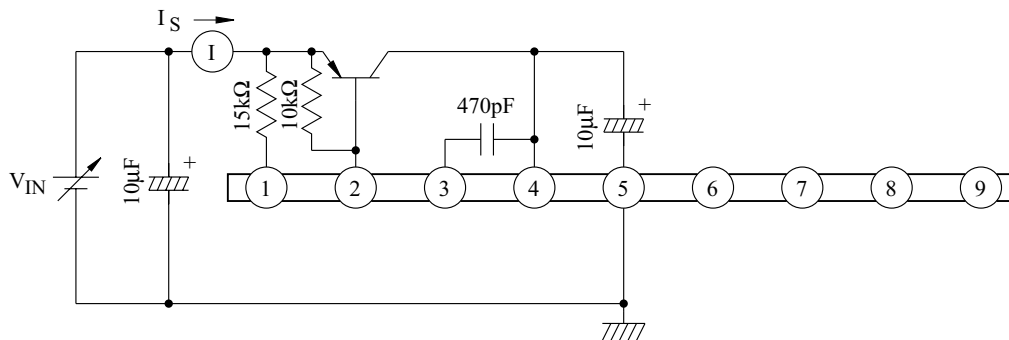

KIA8000S

RESET TIMER EQUIVALENT CIRCUIT

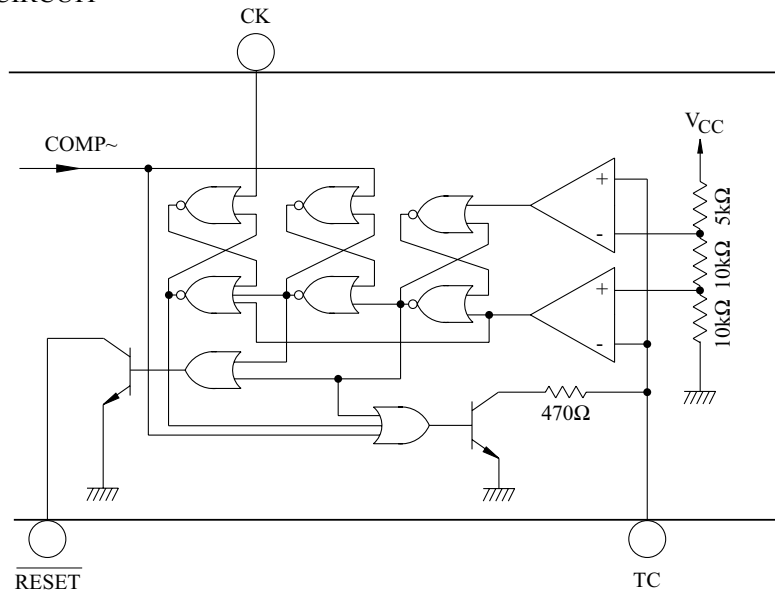

EXAMPLE OF APPLICATION CIRCUIT

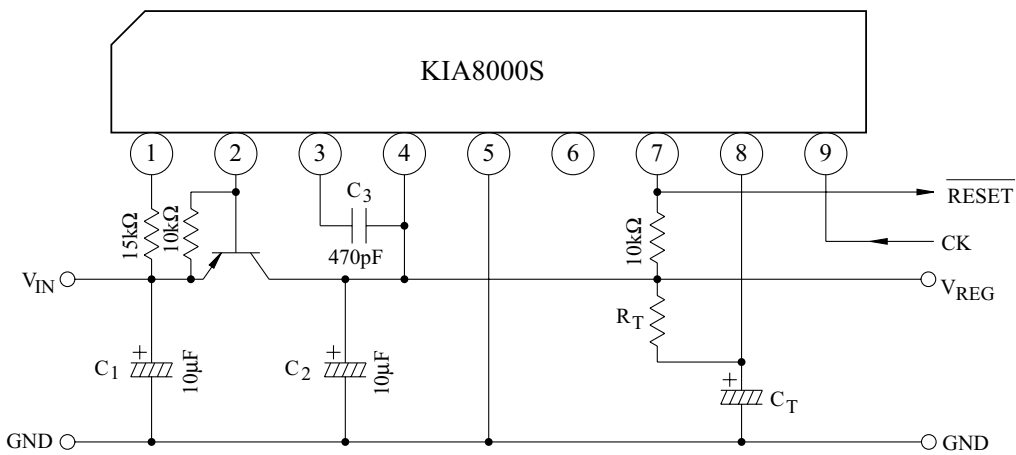

* Cautions for wiring

1. C_1 and C_2 are for absorbing disturbance, noise, etc. Connect them as close to the IC as possible.
2. C_3 is for phase compensation. Also, connect C_3 close to the IC.

120V V_{peak} LOAD DUMP

Note : No protection is needed if a voltage above 80V is not applied.

1. Low output current circuit

$I_{LOAD}=10\text{mA Max. } V_{BATT}=6 \sim 17\text{V}$

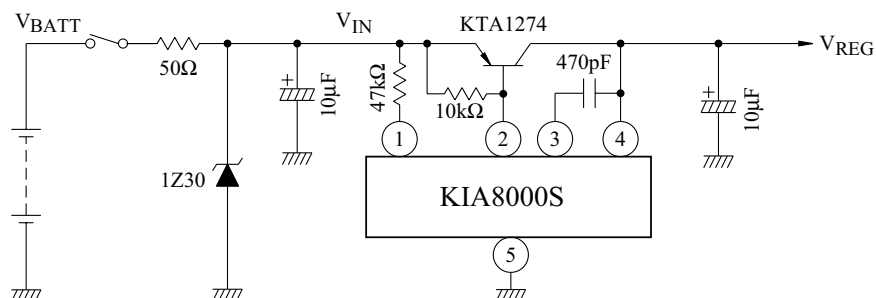

KIA8000S

2. High output current circuit.

$I_{LOAD}=300\text{mA Max. } V_{BATT}=6 \sim 17\text{V}$

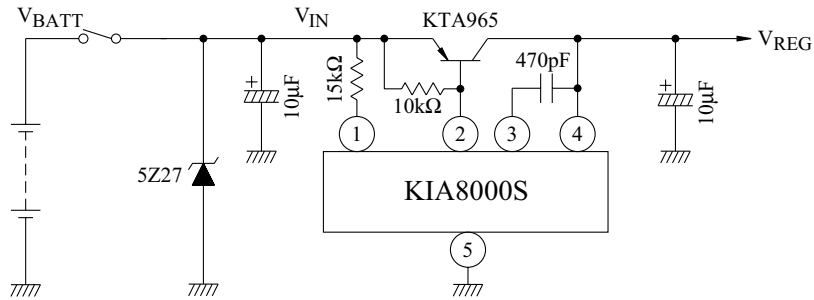

EXAMPLE OF APPLICATION CIRCUIT USING DARLINGTON TRANSISTOR

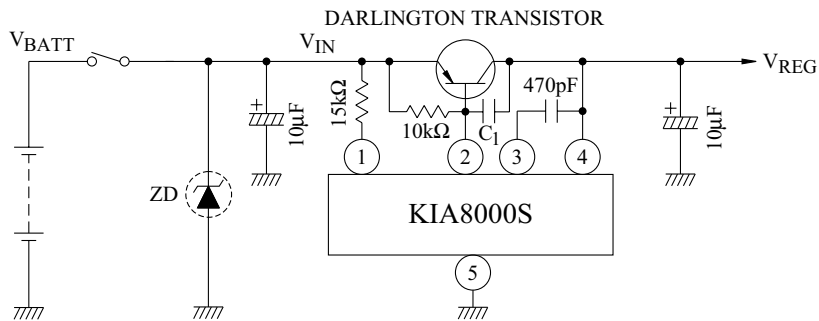

- * · Select a C1 value according to the working condition : typically above 2000pF.
- Insert ZD when necessary.

APPLICATION CIRCUIT OF WATCHDOG/RESET TIMER

1. $T_{RST(1)} \cong 10\text{mS}$ Power On Reset Timer.

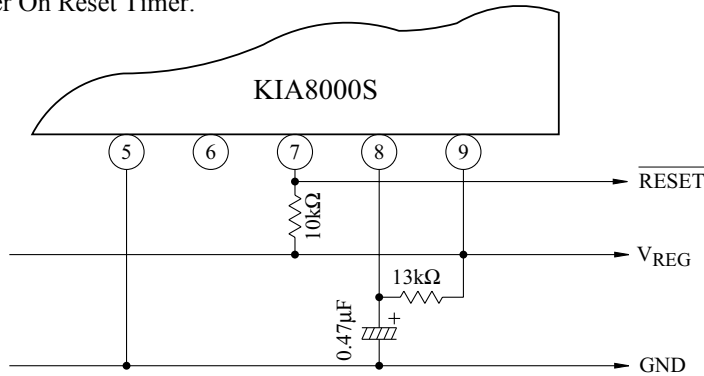

2. $T_{RST(1)} \cong 1.5T_{WD}$

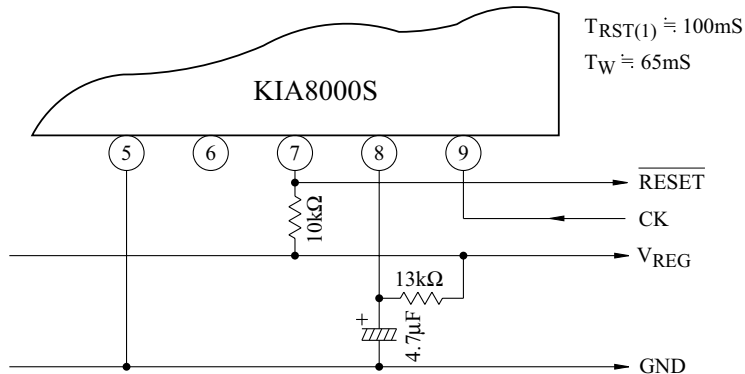

KIA8000S

3. $T_{RST(1)} \cong 100\text{ms}$, $T_{WD} \cong 300\text{ms}$

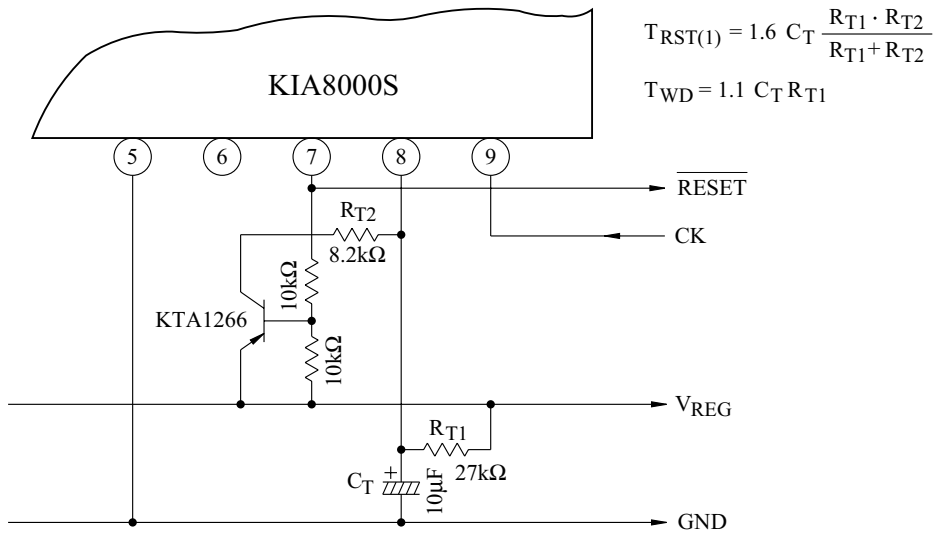

4. RECOMMENDED CONDITIONS

PARTS NAME	MIN.	MAX.	UNIT
C_T	0.01	100	μF
R_T	5	100	$\text{k}\Omega$
R_{T1}	-	100	$\text{k}\Omega$
R_{T1}/R_{T2} (Note)	5	-	$\text{k}\Omega$

Note) $R_{T1}/R_{T2} = (R_{T1} \times R_{T2}) / (R_{T1} + R_{T2})$

APPLICATION CIRCUIT OF CK INPUT

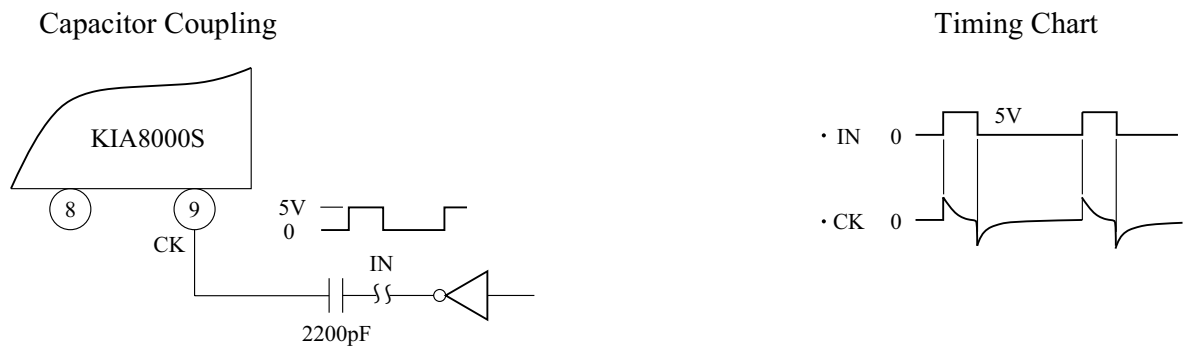

The capacitor coupling allows reset pulses to be supplied intermittently from the $\overline{\text{RESET}}$ pin whether the input level (IN) is high or low.

KIA8000S

1. Input-output characteristic ($R_L=25\Omega$, external transistor KTA965)

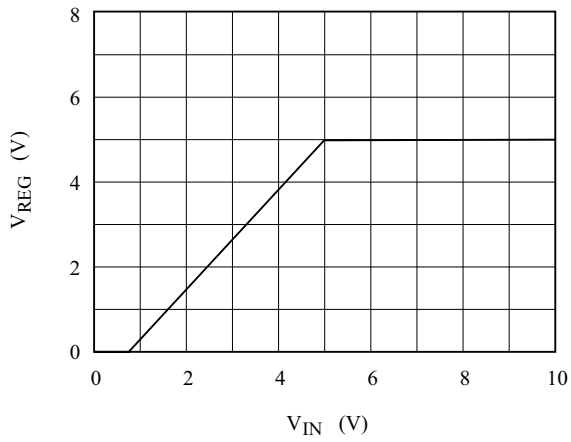

2. Reset Output Characteristic

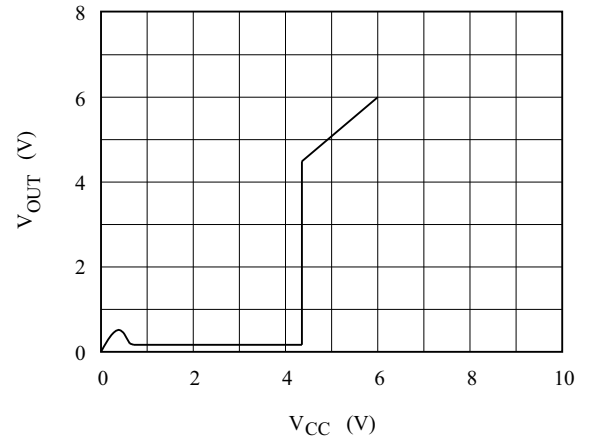

3. Output Adjusting Resistance Characteristic

