

MAX POWER 40W QUAD BTL AUDIO POWER AMPLIFIER

The KIA8260AH is 4ch BTL audio power amplifier for car audio application.

This IC can generate more high power : $P_{OUTMAX}=40W$ as it is included the pure complementary PNP and NPN transistor output stage.

It is designed low distortion ratio for 4ch BTL audio power amplifier, built-in Stand-by Function, Muting Function, Clip detector, and diagnosis circuit. Additionally, the AUX, amplifier is built-in, it can make the beep signal etc. output to 2 channels (OUT1 and 4). It contains various kind of protectors for car audio use.

FEATURES

- High Power
 - : $P_{OUTMAX}(1)=40W(Typ.)$
($V_{CC}=14.4V$, $f=1kHz$, EIAJ Max., $R_L=4\Omega$)
 - : $P_{OUTMAX}(2)=37W(Typ.)$
($V_{CC}=13.7V$, $f=1kHz$, EIAJ Max., $R_L=4\Omega$)
 - : $P_{OUT}(1)=24W(Typ.)$
($V_{CC}=14.4V$, $f=1kHz$, THD=10%, $R_L=4\Omega$)
 - : $P_{OUT}(2)=21W(Typ.)$
($V_{CC}=13.2V$, $f=1kHz$, THD=10%, $R_L=4\Omega$)
- Built-in clip detector & diagnosis circuit. (Pin③)
- Low Distortion Ratio
 - : THD=0.02%(Typ.)
($V_{CC}=13.2V$, $f=1kHz$, $P_{out}=3W$, $R_L=4\Omega$)
- Low Noise
 - : $V_{NO}=0.16mV_{rms}(Typ.)$
($V_{CC}=13.2V$, $R_g=0\Omega$, $G_v=26dB$, $BW=20\sim 20kHz$)
- Built-in stand-by switch function. (Pin②)
- Built-in muting function. (Pin④)
- Built-in AUX. amplifier from single input to 2 channels output (Pin⑥)
- Built-in junction temperature detection circuit (pin③)
 - : pin③ DC voltage rises at about $+5mV/^{\circ}C$ in proportion to junction temperature.
- Built-in various protection circuit.
 - : Thermal shut down, over voltage, out to GND, out to V_{CC} , out to out short.
- Operating supply voltage.
 - : $V_{CC(opr)}=9\sim 18V$.

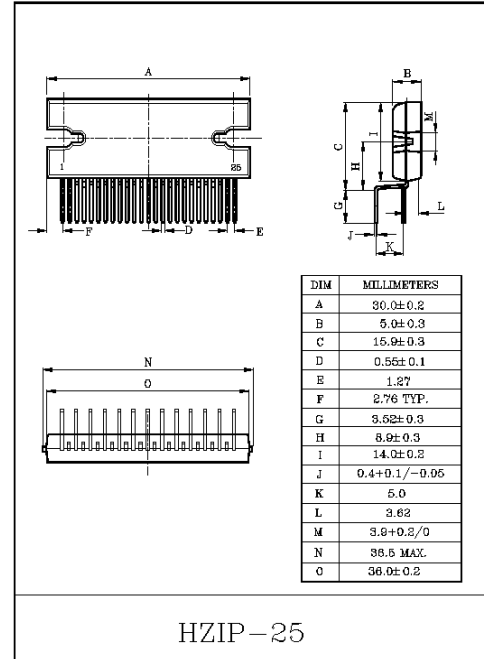

KIA8260AH

MAXIMUM RATINGS (Ta=25°C)

CHARACTERISTIC	SYMBOL	RATING	UNIT
Peak Supply Voltage (0.2sec)	V _{CC (surge)}	50	V
DC Supply Voltage	V _{CC (DC)}	25	V
Operating Supply Voltage	V _{CC (opr)}	18	V
Output Current (Peak)	I _{O (peak)}	9	A
Power Dissipation	P _D *	250	W
Operating Temperature	T _{opr}	-40~85	°C
Storage Temperature	T _{stg}	-55~150	°C

* : Package thermal resistance $\theta_{j-T}=0.5^{\circ}\text{C}/\text{W}(\text{Typ.})$
(Ta=25°C, with infinite heat sink)

ELECTRICAL CHARACTERISTICS

(Unless otherwise specified, V_{CC}=13.2V, R_L=4Ω, f=1kHz, Ta=25°C)

CHARACTERISTIC	SYMBOL	TEST CIRCUIT	TEST CONDITION	MIN.	TYP.	MAX.	UNIT
Quiescent Current	I _{CCQ}	-	V _{IN} =0	-	200	400	mA
Output Power	P _{OUT} MAX(1)	-	V _{CC} =14.4V, MAX power	-	40	-	W
	P _{OUT} MAX(2)	-	V _{CC} =13.7V, MAX power	-	37	-	
	P _{OUT} (1)	-	V _{CC} =14.4V, THD=10%	-	24	-	
	P _{OUT} (2)	-	THD=10%	19	21	-	
Total Harmonic Distortion Ratio	THD	-	P _{OUT} =3W	-	0.02	0.2	%
Voltage Gain	G _V	-	V _{OUT} =0.775V _{rms} (0dBm)	24	26	28	dB
Voltage Gain Ratio	ΔG _V	-	V _{OUT} =0.775V _{rms} (0dBm)	-1.0	0	1.0	
Output Noise Voltage	V _{NO} (1)	-	R _g =0Ω, DIN45405	-	0.12	-	mV _{rms}
	V _{NO} (2)	-	R _g =0Ω, BW=20Hz~20kHz	-	0.10	0.35	
Ripple Rejection Ratio	R.R.	-	f _{ripple} =100Hz, R _g =620Ω V _{rip} =0.775V _{rms} (0dBm)	40	50	-	dB
Cross Talk	C.T.	-	R _g =620Ω, V _{OUT} =0.775V _{rms} (0dBm)	-	70	-	
Output Offset Voltage	V _{OFFSET}	-	-	-100	0	+100	mV
Input Resistance	R _{IN}	-	-	-	90	-	kΩ
Stand-By Current	I _{SB}	-	Stand-by condition	-	2	10	μA
Stand-By Control Voltage	V _{SB} H	-	Power : ON	3.0	-	6.0	V
	V _{SB} L	-	Power : OFF	0	-	1.5	
Mute Control Voltage *	V _{SB} H	-	Mute : OFF	OPEN			V
	V _{SB} L	-	Mute : ON, R1=10kΩ	0	-	0.5	
Mute Attenuation	ATT M	-	Mute:on, V _{OUT} =7.75V _{rms} (20dBm) at Mute:off	80	90	-	dB

* : Muting function have to be controlled by open and low logic, which logic is a transistor, FET and μ-COM port of I_{MUTE}>250μA ability. This means that the Mute control terminal : pin② must not be pulled-up.

KIA8260AH

TEST CIRCUIT & BLOCK DIAGRAM

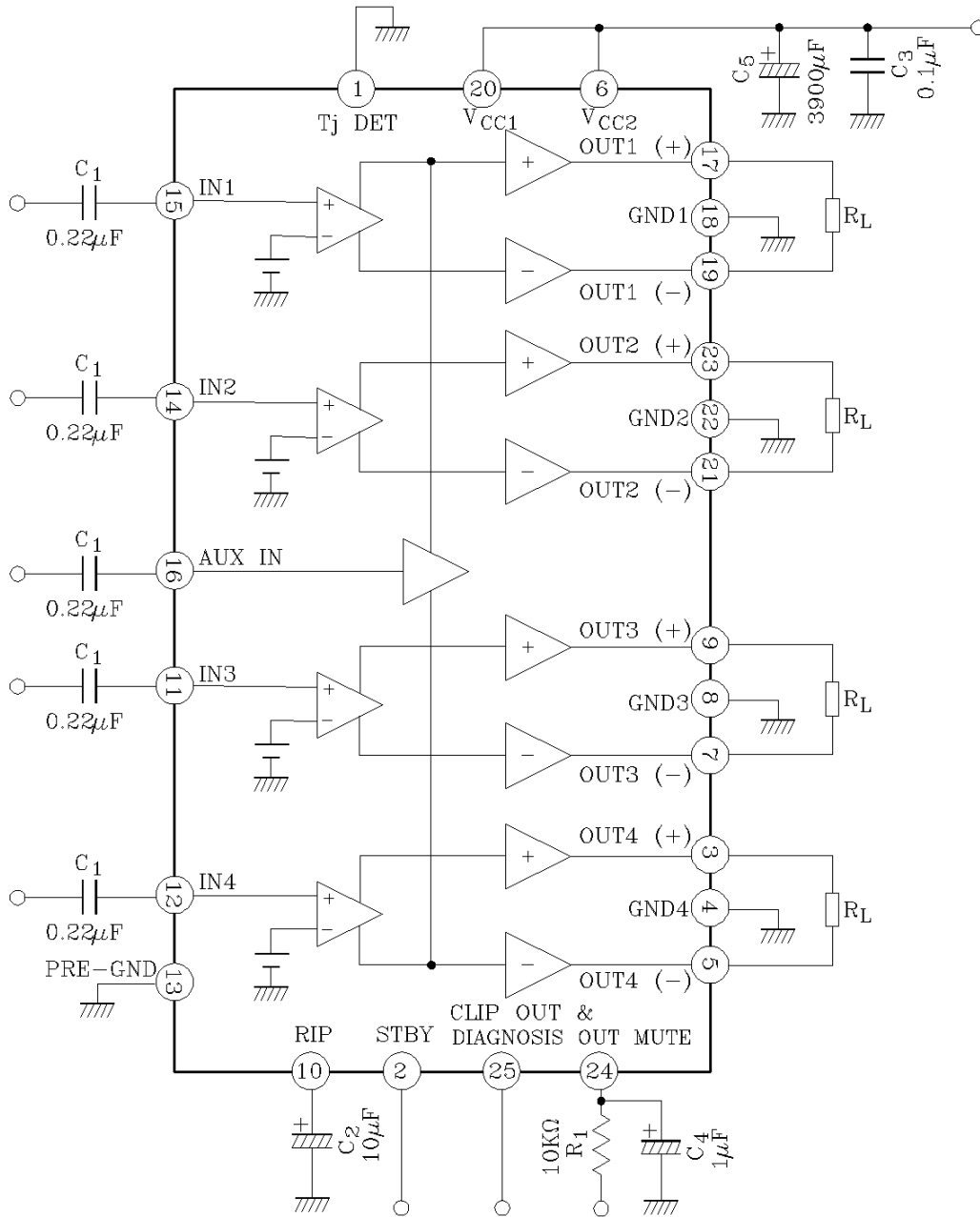

KIA8260AH

CAUTION AND APPLICATION METHOD

(Description is made only no the single channel.)

1. Voltage gain adjustment

This IC has no NF (negative feedback) terminals. Therefore, the voltage gain can't adjusted, but it makes the device a space and total costs saver.

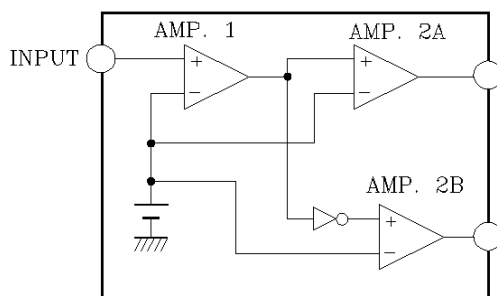

(Fig.1) Block Diagram

The voltage gain of Amp. 1 : $G_{V1}=0\text{dB}$

The voltage gain of Amp. 2A, B : $G_V=20\text{dB}$

The voltage gain of BTL Connection : $G_{V(\text{BTL})}=6\text{dB}$

Therefore, the total voltage gain is decided by expression below.

$$G_V = G_{V1} + G_{V2} + G_{V(\text{BTL})} = 0 + 20 + 6 = 26\text{dB}$$

2. Stand-by SW function (pin②)

By means of controlling pin② (Stand-by terminal) to High and Low, the power supply can be set to ON and OFF.

The threshold voltage of pin② is set at about $3V_{\text{BE}}(\text{Typ.})$, and the power supply current is about $2\mu\text{A}(\text{Typ.})$ at the Stand-by state.

Control Voltage of pin② : $V_{(\text{SB})}$

STAND-BY	POWER	$V_{(\text{SB})}$ (V)
ON	OFF	0~1.5
OFF	ON	3~6

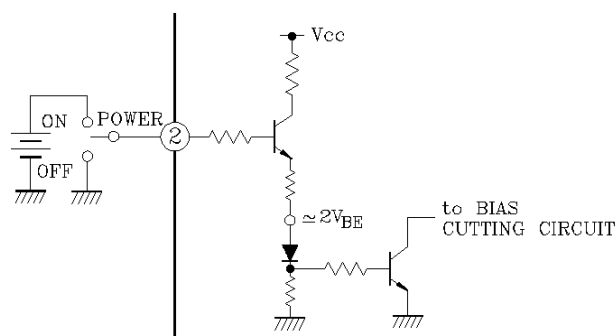

(Fig.2) With pin ② set to High, Power is turned ON

Adjustage of Stand-by SW

- (1) Since V_{CC} can directly be controlled to ON or OFF by the microcomputer, the switching relay can be omitted.
- (2) Since the control current is microscopic, the switching relay of small current capacity is satisfactory for switching

KIA8260AH

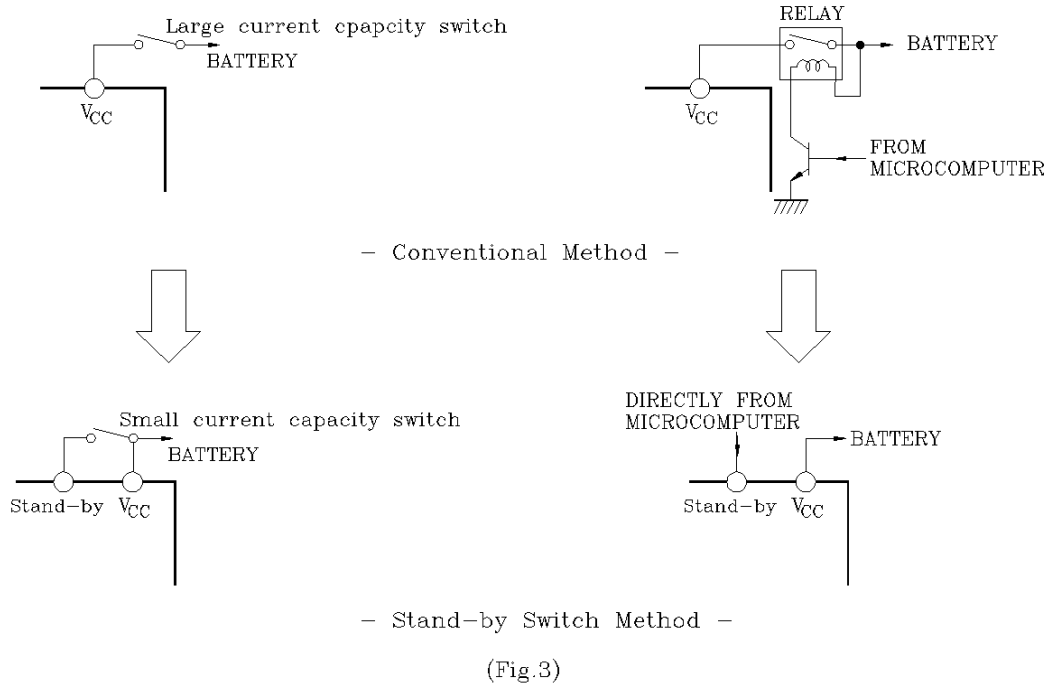

3. Muting function (pin⑳)

By means of controlling pin⑳ less than 0.5V, it can make the audio muting condition.

The muting time constant is decided by R_1 and C_4 and these parts is related the pop noise at power ON/OFF.

The series resistance ; R_1 must be set up less than $15k\Omega$, we recommend $10k\Omega$.

The muting function have to be controlled by a transistor, FET and μ -COM port which has $I_{MUTE} > 250\mu A$ ability.

Terminal ⑳ must not be pulled up and it shall be controlled by OPEN/LOW.

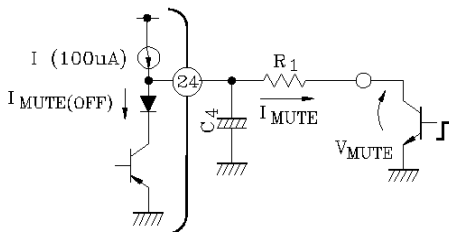

(Fig.4) Muting Function

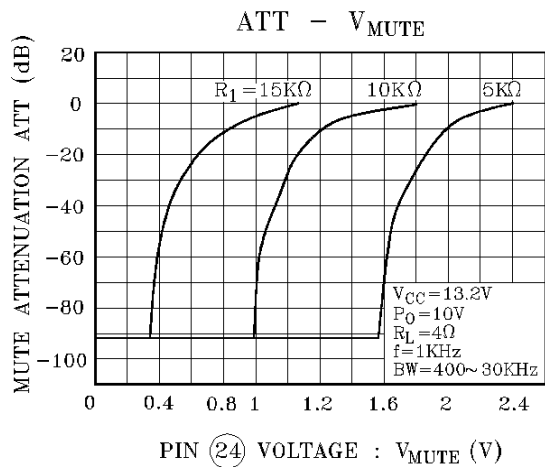

KIA8260AH

4. AUX. Input (pin⑩)

The pin⑩ is for input terminal of AUX. amplifier.
The total gain is 0dB by using of AUX. amplifier.
Therefore, the μ -COM can directly drive the AUX.
amplifier.

BEEP sound or voice synthesizer signal can be input
to pin⑩ directly.

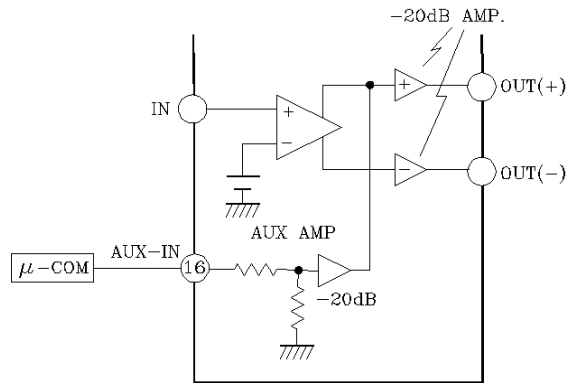

(Fig.6) AUX INPUT

5. DIAGNOSIS OUTPUT (pin③)

The diagnosis output terminal of pin③ has open collector output structure on chip as shown in Fig.6.

In unusual case that output terminal of Power Amp. is condition of output to V_{CC} or output to GND short and over voltage input mode, it is possible to protect all the system of apparatus as well as power IC protection.

In case of being unused this function, use this IC as open-connection on pin③.

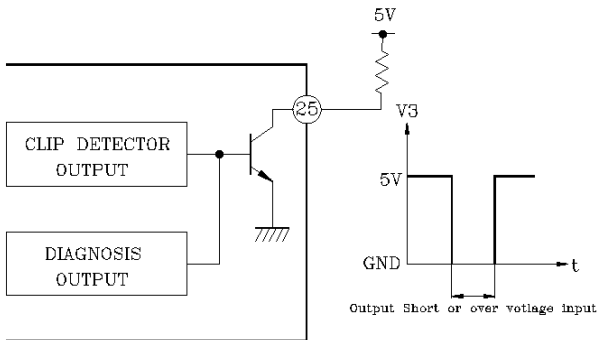

PIN ②⑤ : Open Collector Output (Active Low)

(Fig.7)

(Application)

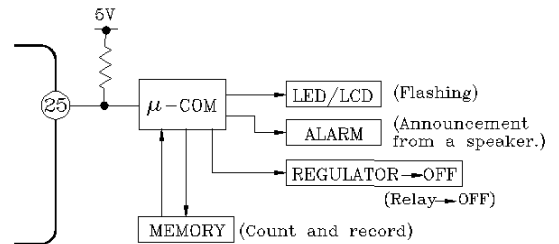

(Fig.8)

KIA8260AH

6. Output Clip Detection Function (pin③)

The output clip detection terminal of pin③ has the open collector output structure on chip as shown in Fig.9 In case that the output waveform is clipping, the clip detection circuit is operated and NPN Tr. is turned on.

It is possible to improve the audio quality with controlling the volume, tone control circuit through L.P.F. smoothing circuit as shown in Fig.9.

In case of being unused this function, use this IC as open connection on pin③.

(Application)

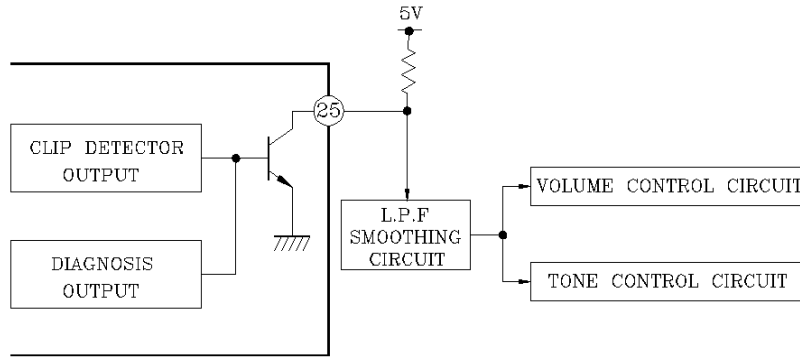

PIN ②⑤ : Open Collector Output (Active Low)

(Fig.9)

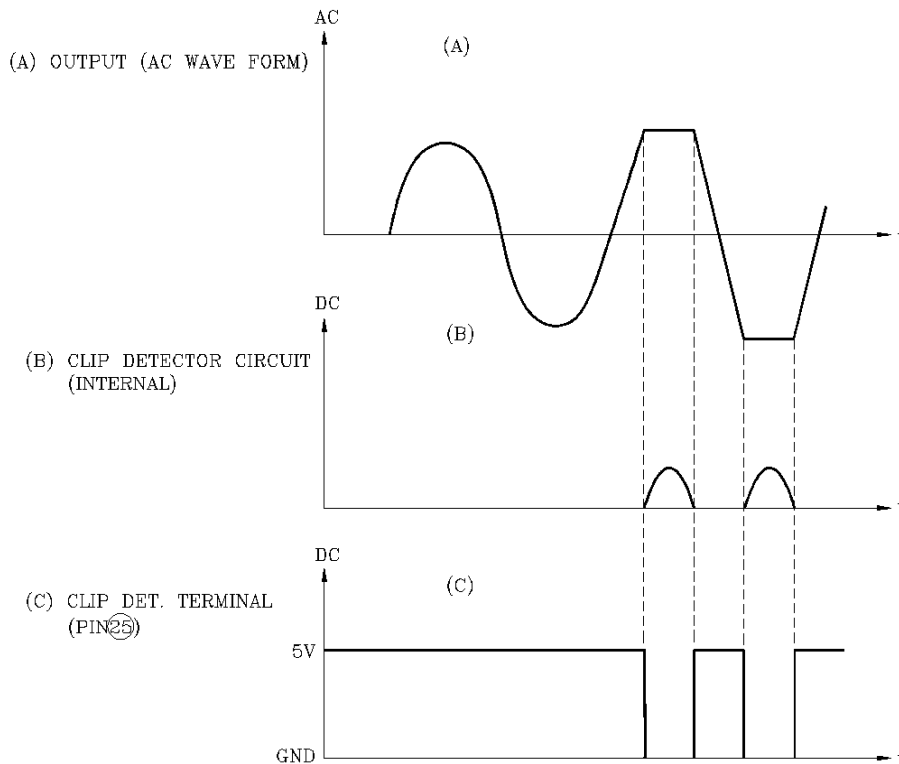

KIA8260AH

7. Junction temperature detecting pin⑳

Using temperature characteristic of a band gap circuit and in proportion to junction temperature, pin⑳ DC voltage : V_{23} rises at about $+5\text{mV}/^\circ\text{C}$ temperature characteristic. The relation between V_{23} at $T_j=25^\circ\text{C}$ and V_{23x} at $T_j=x^\circ\text{C}$ is decided by the following expression :

$$T(x^\circ\text{C}) = \frac{V_{23} - V_{23}(25^\circ\text{C})}{5\text{mV}/^\circ\text{C}} + 25(^\circ\text{C})$$

In deciding a heat sink size, a junction temperature can be easily made clear by measuring voltage at this pin while a backside temperature of IC was so far measured using a thermocouple type thermometer.

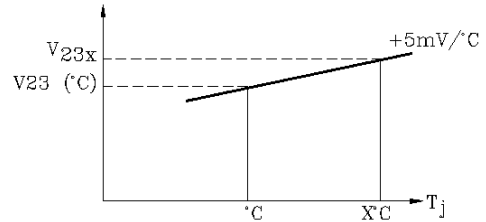

(Fig.10)

8. Cross talk

The cross talk characteristics of the IC is not good between OUT1 and 2, OUT3 and 4. So we recommend to use by below method.

OUT1,2	L-ch (or R-ch)
OUT3,4	R-ch (or L-ch)

And, please refer to below table in case of applying the AUX, IN because it is out to OUT1 and 4.

ex)

OUT1	Front	L-ch (or R-ch)	AUX. OUT
OUT2	Rear		-
OUT3	Rear	R-ch (or L-ch)	-
OUT4	Front		AUX. OUT

KIA8260AH

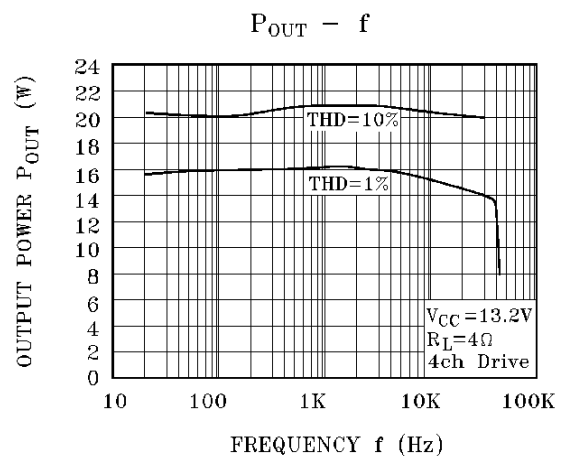
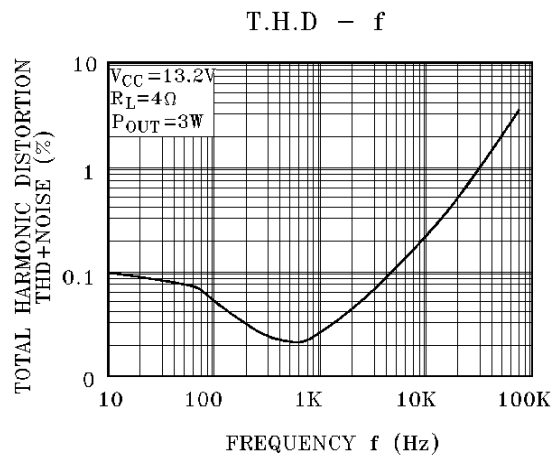
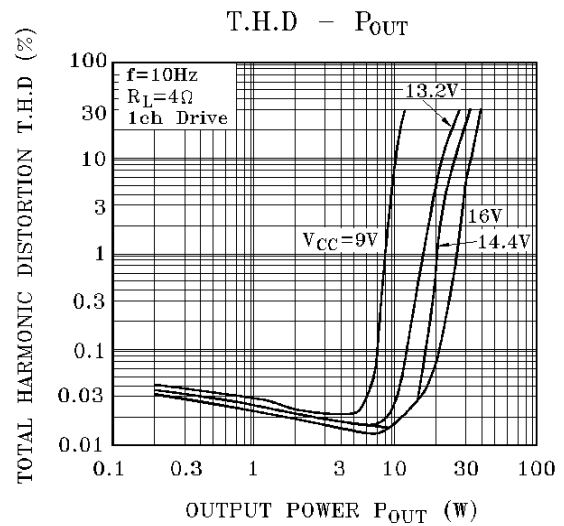
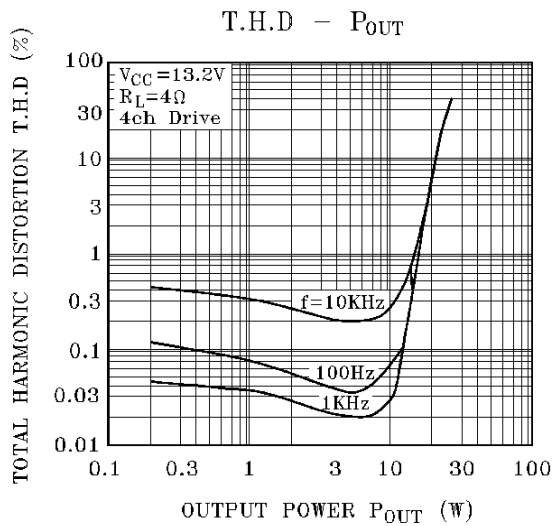
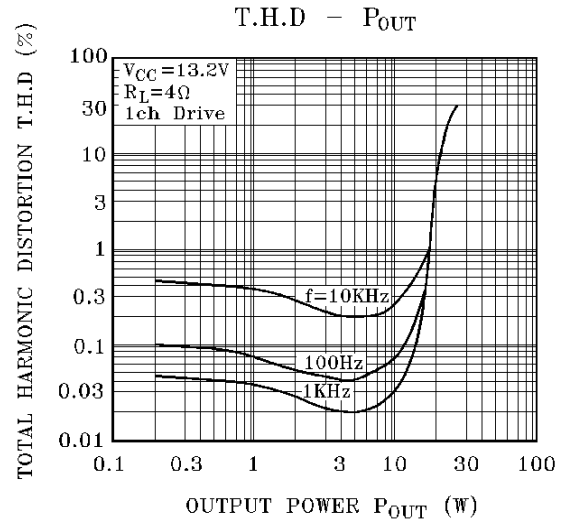
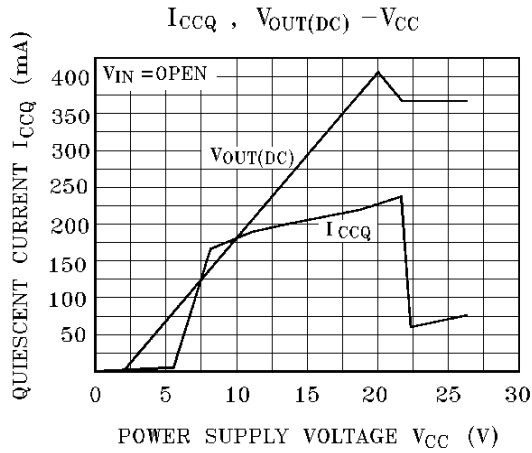

KIA8260AH

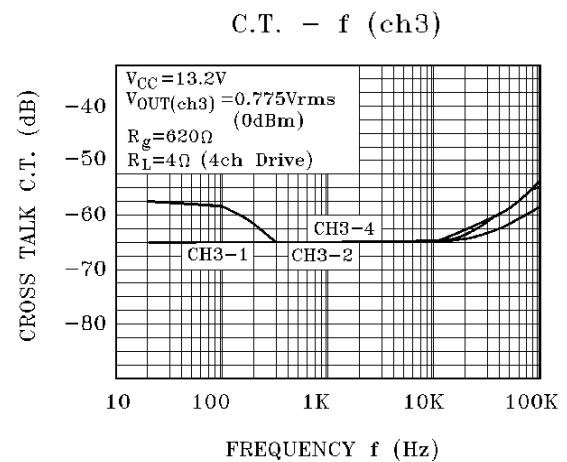
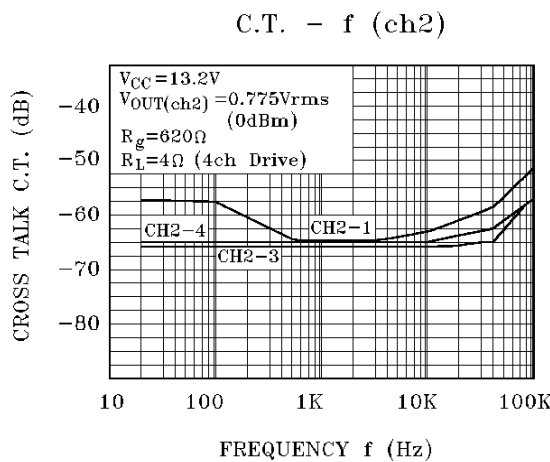
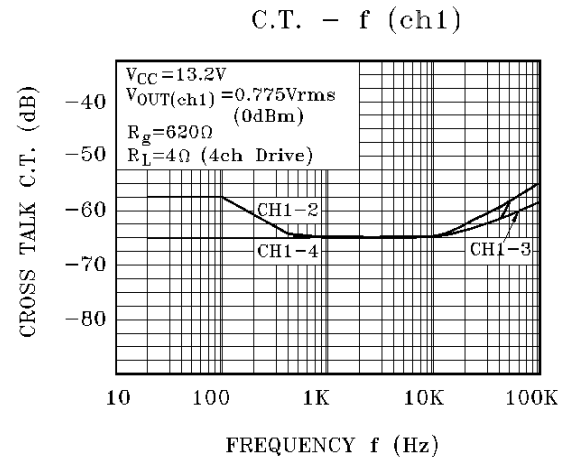
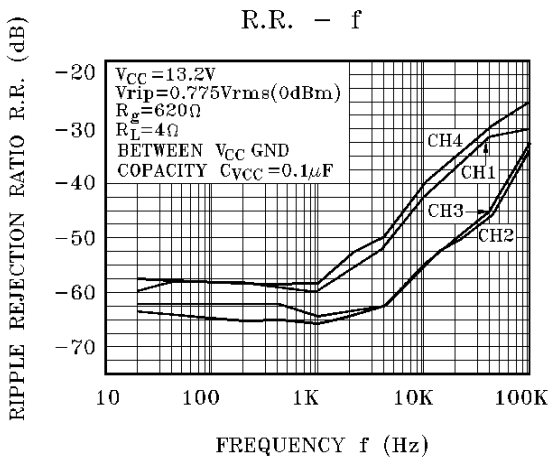
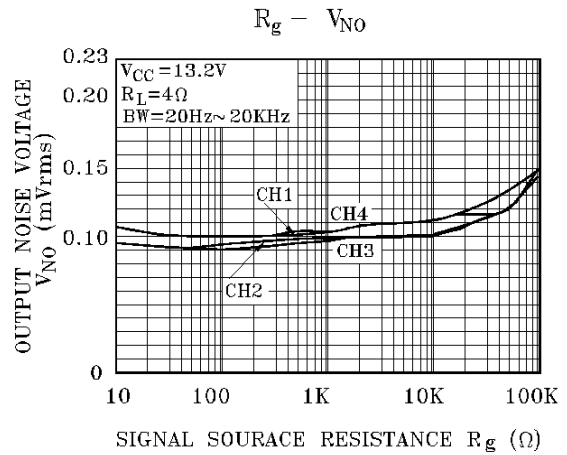
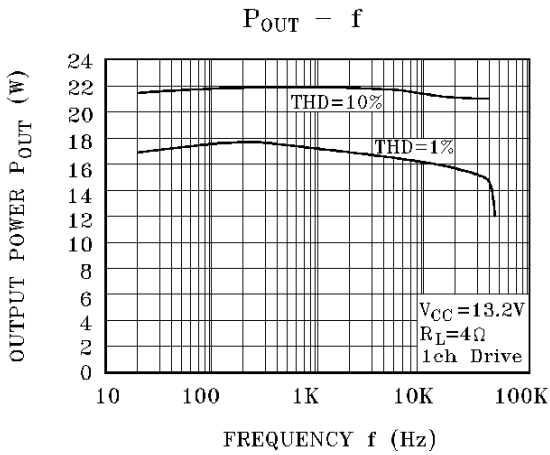

KIA8260AH

C.T. - f (ch4)

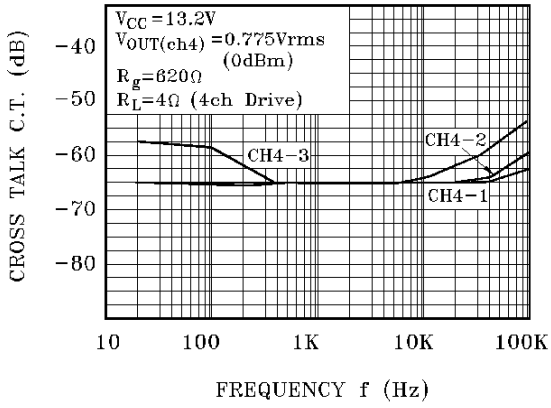

P_D - P_{OUT}

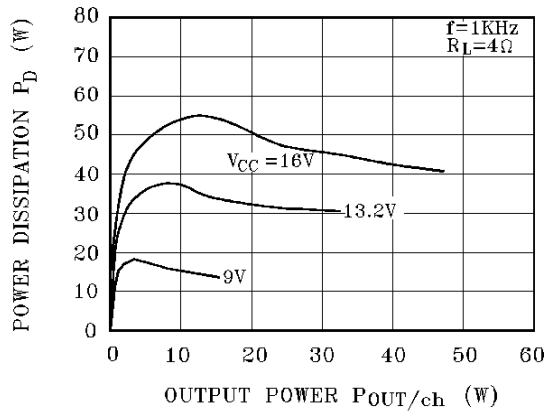

P_D MAX - P_{OUT}

