

BUS BUFFER, 3-STATE OUTPUT

FEATURES

- High Output Drive : $\pm 24\text{mA}$ (Typ.) @ $V_{CC}=3\text{V}$
- Super High Speed Operation : $t_{PD}=2.6\text{ns}$ (Typ.) @ $V_{CC}=5\text{V}$, 50pF
- Operation Voltage Range : $V_{CC(\text{opr})}=1.8 \sim 5.5\text{V}$.

MAXIMUM RATINGS (Ta=25 °C)

CHARACTERISTIC	SYMBOL	RATING	UNIT
Supply Voltage Range	V_{CC}	-0.5 ~ 6	V
DC Input Voltage	V_{IN}	-0.5 ~ 6	V
DC Output Voltage	V_{OUT}	-0.5 ~ 6	V
Input Diode Current	I_{IK}	± 20	mA
Output Diode Current	I_{OK}	± 20	mA
DC Output Current	I_{OUT}	± 50	mA
DC V_{CC} /Ground Current	I_{CC}	± 50	mA
Power Dissipation	P_D	200	mW
Storage Temperature	T_{stg}	-65 ~ 150	°C
Lead Temperature (10s)	T_L	260	°C

LOGIC DIAGRAM

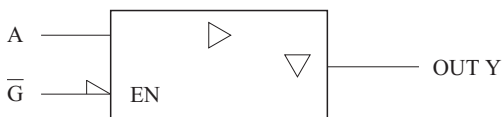

Truth Table

INPUTS		OUTPUTS
\bar{G}	A	Y
H	X	Z
L	L	L
L	H	H

X : Don't Care

Z : High Impedance

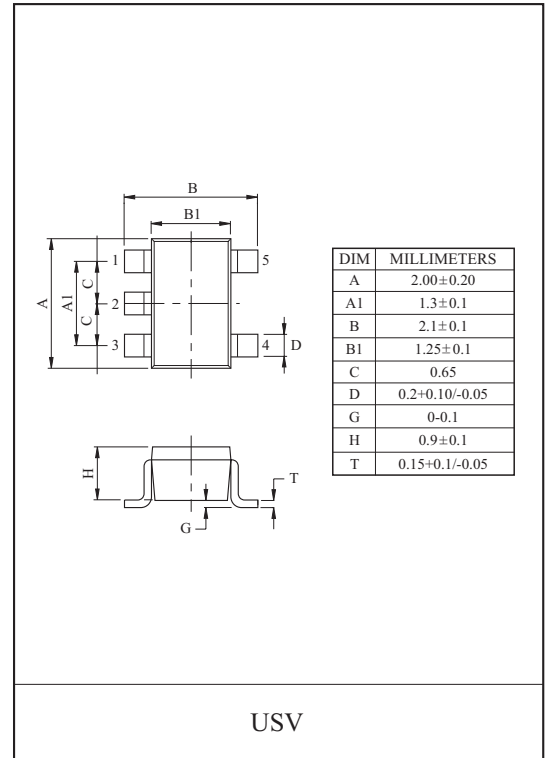

MARKING

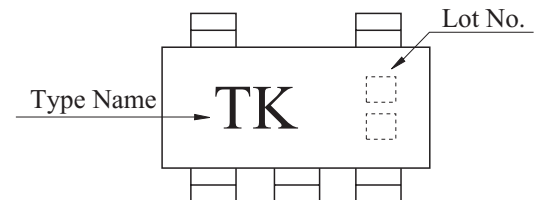

PIN CONNECTION(TOP VIEW)

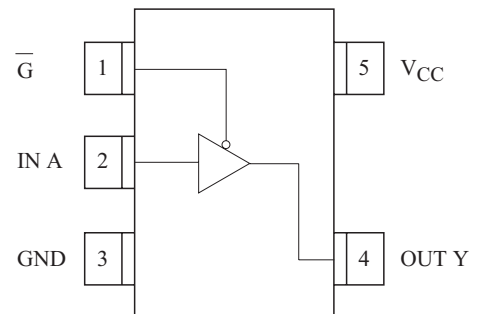

KIC7SZ125FU

RECOMMENDED OPERATING CONDITIONS

CHARACTERISTIC	SYMBOL	RATING	UNIT
Supply Voltage	V_{CC}	1.8~5.5	V
		1.5~5.5 (Note1)	
Input Voltage	V_{IN}	0~5.5	V
Output Voltage	V_{OUT}	0~5.5 (Note2)	V
		0~ V_{CC} (Note3)	
Operating Temperature	T_{opr}	-40~85	°C
Input Rise and Fall Time	dt/dv	0~20 ($V_{CC}=1.8V, 2.5V \pm 0.2V$)	ns/V
		0~10 ($V_{CC}=3.3V \pm 0.3V$)	
		0~5 ($V_{CC}=5.5V \pm 0.5V$)	

Note1) Data retention only. Note2) $V_{CC}=0V$ Note3) H and Low state

DC ELECTRICAL CHARACTERISTICS

CHARACTERISTIC	SYMBOL	TEST CONDITION	$T_a=25\text{ }^\circ\text{C}$			$T_a=-40\sim 85\text{ }^\circ\text{C}$		UNIT		
			$V_{CC}(V)$	MIN.	TYP.	MAX.	MIN.		MAX.	
High-Level Input Voltage	V_{IH}	-	1.8	0.88 $\times V_{CC}$	-	-	0.88 $\times V_{CC}$	-	V	
			2.3~5.5	0.75 $\times V_{CC}$	-	-	0.75 $\times V_{CC}$	-		
Low-Level Input Voltage	V_{IL}	-	1.8	-	-	0.12 $\times V_{CC}$	-	0.12 $\times V_{CC}$	V	
			2.3~5.5	-	-	0.25 $\times V_{CC}$	-	0.25 $\times V_{CC}$		
High-Level Output Voltage	V_{OH}	$V_{IN}=V_{IH}$ or V_{IL}	$I_{OH}=-100\mu A$	1.8	1.7	1.8	-	1.7	-	V
				2.3	2.2	2.3	-	2.2	-	
				3.0	2.9	3.0	-	2.9	-	
				4.5	4.4	4.5	-	4.4	-	
			$I_{OH}=-8mA$	2.3	1.9	2.15	-	1.9	-	
			$I_{OH}=-16mA$	3.0	2.4	2.8	-	2.4	-	
			$I_{OH}=-24mA$	3.0	2.3	2.68	-	2.3	-	
Low-Level Output Voltage	V_{OL}	$V_{IN}=V_{IH}$ or V_{IL}	$I_{OL}=100\mu A$	1.8	-	0	0.1	-	0.1	V
				2.3	-	0	0.1	-	0.1	
				3.0	-	0	0.1	-	0.1	
				4.5	-	0	0.1	-	0.1	
			$I_{OL}=8mA$	2.3	-	0.1	0.3	-	0.3	
			$I_{OL}=16mA$	3.0	-	0.15	0.4	-	0.4	
			$I_{OL}=24mA$	3.0	-	0.22	0.55	-	0.55	
			$I_{OL}=32mA$	4.5	-	0.22	0.55	-	0.55	
Input Leakage Current	I_{IN}	$V_{IN}=5.5V$ or GND	0~5.5	-	-	± 1	-	± 10	μA	
3-state Output off-State Current	I_{OZ}	$V_{IN}=V_{IH}$ or V_{IL} $V_{OUT}=0\sim 5.5V$	1.8~5.5	-	-	± 1	-	± 10		
Quiescent Supply Current	I_{CC}	$V_{IN}=V_{CC}$ or GND	5.5	-	-	2	-	20		

KIC7SZ125FU

AC ELECTRICAL CHARACTERISTICS (Input $t_r=t_f=3ns$)

CHARACTERISTIC	SYMBOL	TEST CONDITION	Ta=25 °C			Ta=-40 ~85 °C		UNIT	
			V _{CC} (V)	MIN.	TYP.	MAX.	MIN.		MAX.
Propagation Delay Time	t_{PLH} t_{PHL}	$C_L=15pF$, $R_L=1M \Omega$ (Figure 1)	1.8	2.0	5.3	11.0	2.0	11.5	ns
			2.5 ± 0.2	0.8	3.4	7.5	0.8	8.0	
			3.3 ± 0.3	0.5	2.5	5.2	0.5	5.5	
		$C_L=50pF$, $R_L=500 \Omega$ (Figure 1)	5.0 ± 0.5	0.5	2.1	4.5	0.5	4.8	
			3.3 ± 0.3	1.5	3.2	5.7	1.5	6.0	
			5.0 ± 0.5	0.8	2.6	5.0	0.8	5.3	
Output Enable Time	t_{PZL} t_{PZH}	$C_L=50pF$, $R_L=500 \Omega$ (Figure 1)	1.8	2.0	7.0	12.5	2.0	13.0	ns
			2.5 ± 0.2	1.5	4.6	8.0	1.5	9.0	
			3.3 ± 0.3	1.5	3.5	6.2	1.5	6.5	
			5.0 ± 0.5	0.8	2.8	5.5	0.8	5.8	
Output Disable Time	t_{PZL} t_{PZH}	$C_L=50pF$, $R_L=500 \Omega$ (Figure 1)	1.8	2.0	5.4	11.0	2.0	12.0	ns
			2.5 ± 0.2	1.5	3.5	8.0	1.5	8.5	
			3.3 ± 0.3	1.0	2.8	5.7	1.0	6.0	
			5.0 ± 0.5	0.5	2.1	4.7	0.5	5.0	
Input Capacitance	C_{IN}	-	0 ~ 5.5	-	4	-	-	-	pF
Power Dissipation Capacitance	C_{PD}	(Note 1)	3.3	-	17	-	-	-	pF
			3.5	-	24	-	-	-	

Note 1 : C_{PD} defined as the value of internal equivalent capacitance of IC which is calculated from the operating current consumption without load (refer to Test Circuit.) Average operating current can be obtained by the equation hereunder.

$$I_{CC(opr)} = C_{PD} \cdot V_{CC} \cdot f_{IN} + I_{CC}$$

Fig. 1 AC CHARACTERISTICS MEASUREMENT CIRCUIT

