

HIGH VOLTAGE ANALOG FUNCTION SWITCH ARRAY

The KIC9162AN/AF, KIC9163AN/AF and KIC9164AN/AF are analog switch arrays for high voltage application. By inputting the specified serial data, the analog switches are controlled. As each analog switch is independently controllable, switch of wide use is available.

FEATURES

- Analog switches of 16 circuits are built in, allowing to provide three types according to internal connections.
- Dual power supply of (+) and (-) can be used.
In this case the switch select data is operated in a single power supply by the built-in level shifter.
As the threshold level of the input inverter is designed low, interface with CMOS microcomputer is easily available.
- As the analog switches are high-voltage(30v) use and have superior linearity of on-resistance, extra low distortion and wide dynamic range can be realized.
- Owing to CMOS structure current consumption is low.
- Package is shrunk NDIP-28 and FLP-28 pin.

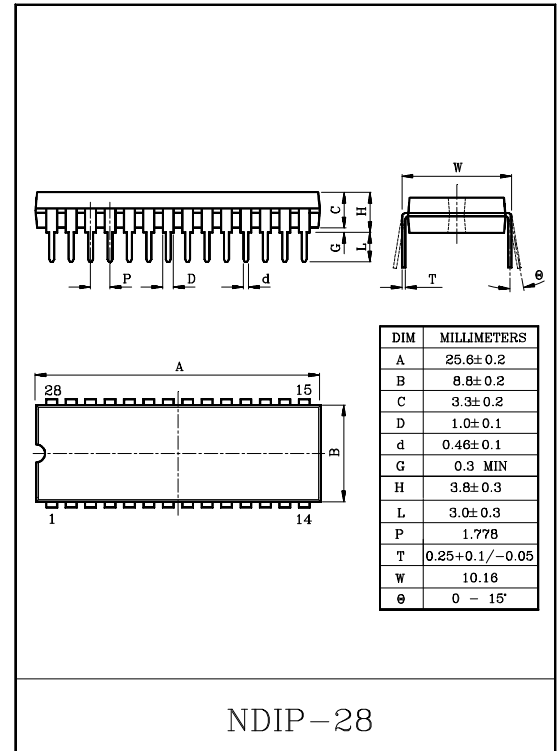

MAXIMUM RATINGS (Ta=25°C)

CHARACTERISTIC	SYMBOL	RATING	UNIT
Supply Voltage (1)	$V_{DD}-V_{SS}$	-0.3~36	V
Supply Voltage (2)	$V_{DD}-GND$	-0.3~20	V
Input Voltage	V_{IN}	$V_{SS}-0.3 \sim V_{DD}+0.3$	V
Power Dissipation	P_D	300	mW
Operating Temperature	T_{opr}	-40~85	°C
Storage Temperature	T_{stg}	-65~150	°C

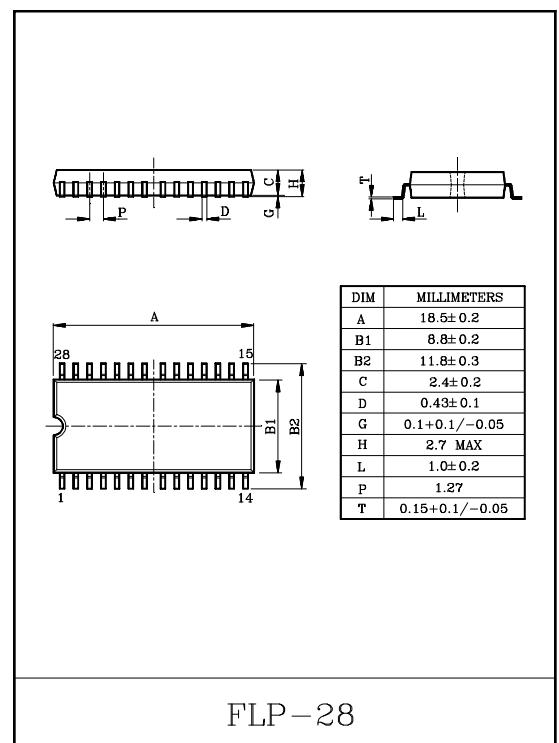

KIC9162AN/AF ~ KIC9164AN/AF

ELECTRICAL CHARACTERISTICS

(Unless otherwise specified, $V_{DD}=15V$, $V_{SS}=-15V$, $GND=0V$, $T_a=25^\circ C$)

CHARACTERISTIC	SYMBOL	TEST CIRCUIT	TEST CONDITION	MIN.	TYP.	MAX.	UNIT
Operating Supply Voltage (1)	$V_{DD}-V_{SS}$	-	Dual power operation	16	~	34	V
Operating Supply Voltage (2)	$V_{DD}-GND$	-	Single power operation	8	~	18	V
Operating Supply Current	I_{DD}	-	No loaded, open	-	0.01	0.1	mA
Back-up Voltage	V_B	-	Data holding voltage	4	~	18	V
Back-up Current	I_B	-	$V_{DD}=4.0V$, $V_{SS}=GND=0V$	-	1	10	μA
Input Voltage	"H" Level	V_{IH}	CK, DATA, ST terminal	4	~	V_{DD}	V
	"L" Level	V_{IL}		GND	~	1.0	
Operating Min. Pulse Width	t_{Min}	-	-	0.5	-	-	μS
Switch-on Resistance	R_{ON}	2	-	-	80	100	Ω
Total Harmonic Distortion	THD	3	$f_{in}=0\sim 20kHz$, $V_{in}=1V_{rms}$	-	0.001	0.005	%
Noise Voltage	V_{NO}	4	$f=20\sim 50kHz$	-	1.0	10	μV_{rms}

DESCRIPTION OF PIN FUNCTIONS (L-ch / R-ch)

PIN NO.			SYMBOL	PIN NAME	FUNCTION & OPERATION	NOTE
KIC9162 AN/AF	KIC9163 AN/AF	KIC9164 AN/AF				
1			V_{SS}	- Power Terminal	Applies Supply Voltage.	-
14			GND	Ground Terminal		
28			V_{DD}	+ Power Terminal		
2/27	2/27	2/27	S_1	Switch Input Terminal	Input & Output Terminal for Analog Switch 	-
3/26	3/26	3/26	S_2			
5/24	4/25	4/25	S_3			
6/23	6/23	5/24	S_4			
8/21	7/22	7/22	S_5			
9/20	8/21	8/21	S_6			
11/18	10/19	10/19	S_7			
-	11/18	11/18	S_8			
4/25	5/24	6/23	COM1	Switch Output Terminal		
7/22	9/20	9/20	COM2			
10/19	12/17	12/17	COM3			
12/17	-	-	COM4			
13			ST	Strobe Input Terminal	Strobe Input for Data Interrupt	Low Threshold Input Terminal
15			CK	Clock Input Terminal	Clock Input for Data Transfer	
16			DATA	Data Input Terminal	Serial Data Input for Switch Setting	

KIC9162AN/AF ~ KIC9164AN/AF

PIN CONNECTION (TOP VIEW)

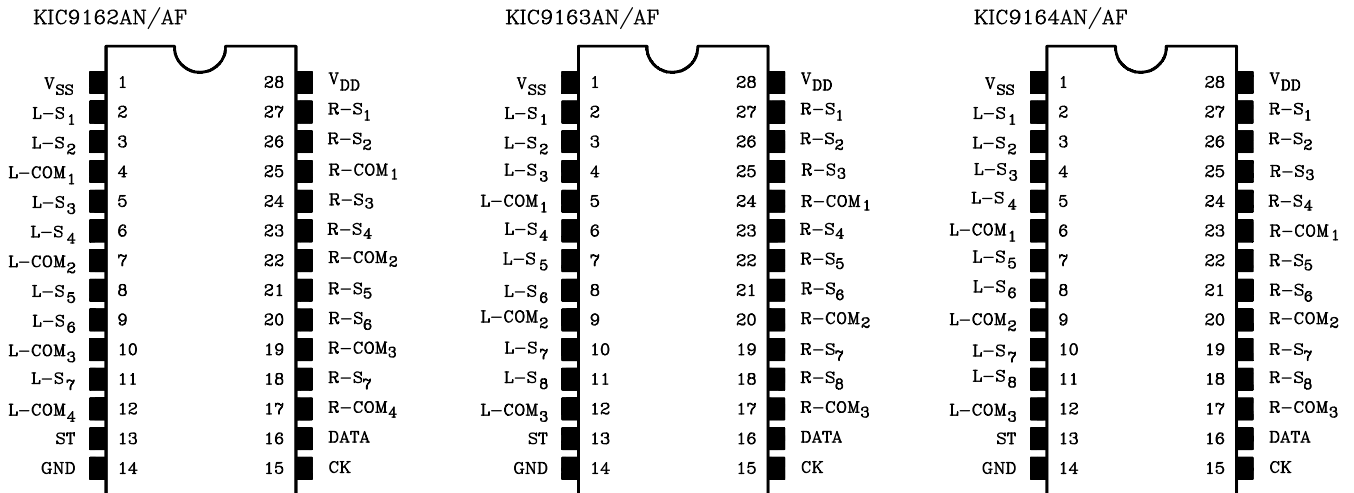

BLOCK DIAGRAM

KIC9162AN/AF

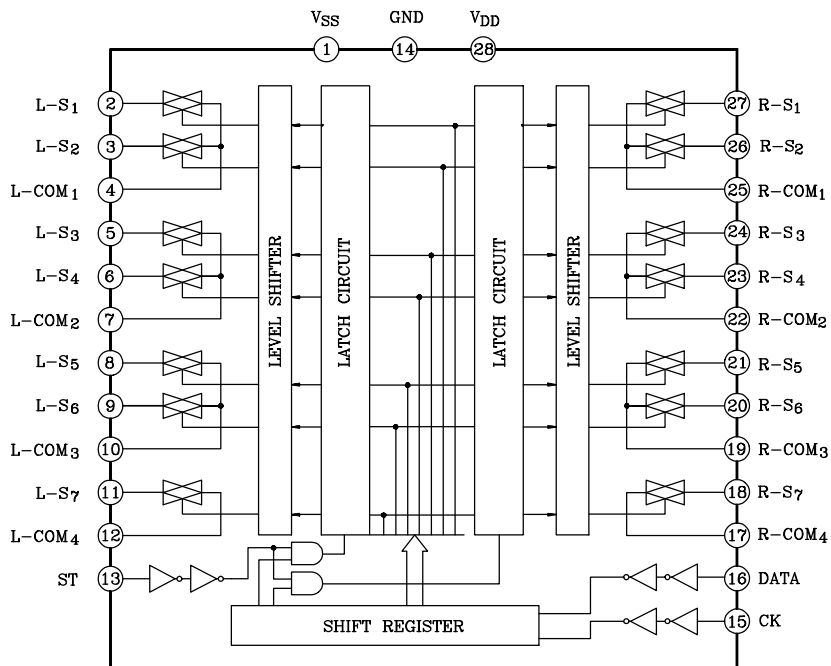

KIC9162AN/AF ~ KIC9164AN/AF

KIC9163AN/AF

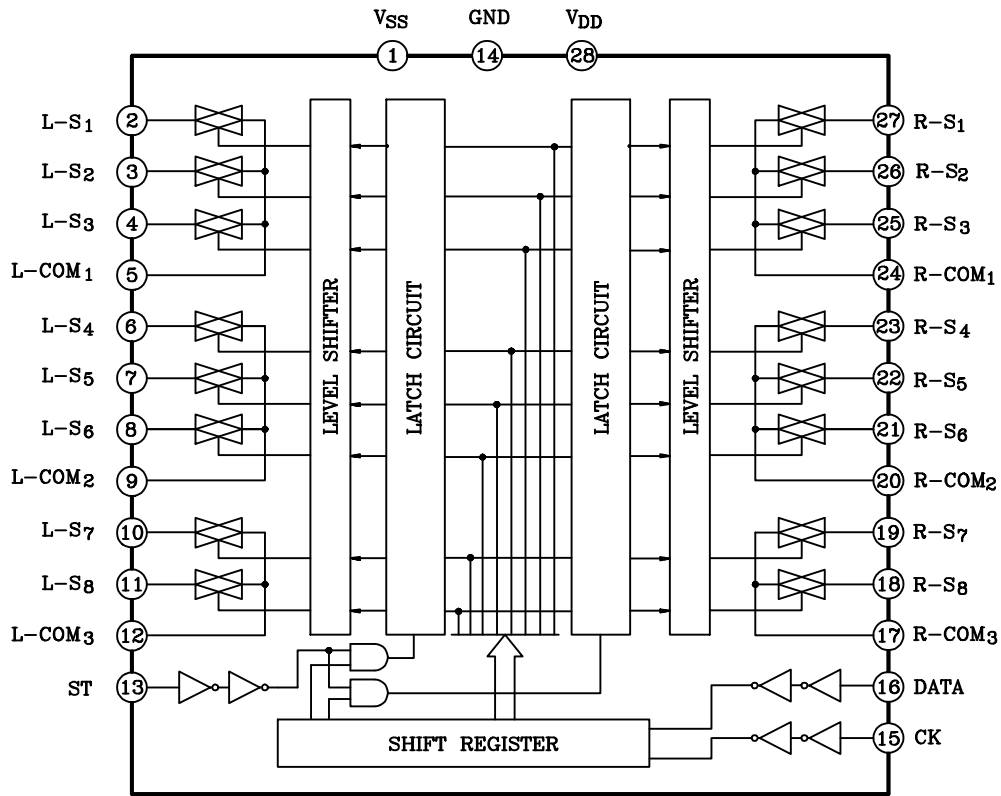

KIC9164AN/AF

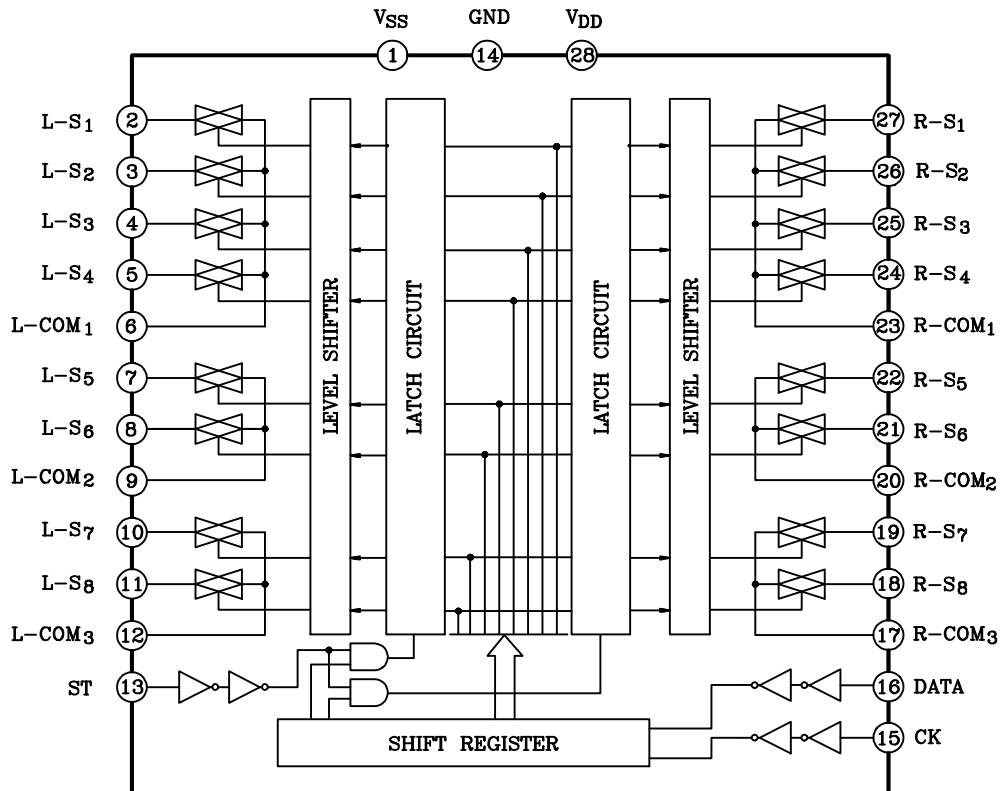

KIC9162AN/AF ~ KIC9164AN/AF

DESCRIPTION OF OPERATION

DATA INPUT

Each analog switch array of KIC9162AN/AF, KIC9163AN/AF and KIC9164AN/AF can be optionally controlled by inputting specified data to DATA, CK, and ST terminals.
The data are composed of 14 bit as follows.

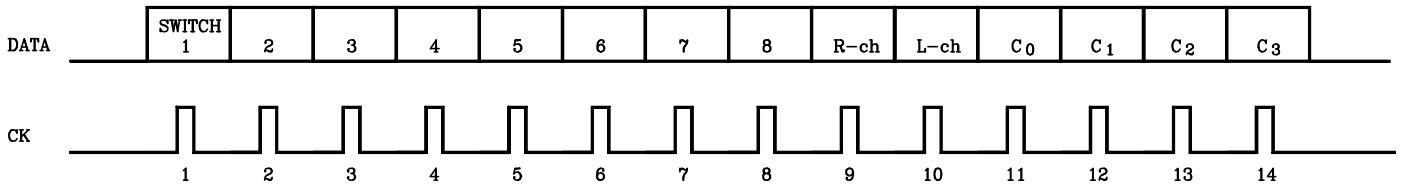

As the bit 1~8 correspond to the analog switches 1 to 8 respectively, set the bit of the desired switch to the level "1" (see Note).

Bit 9 and 10 are channel selecting bit (left and right). when either one of these bit is set to level "1", the desired channel is selected. The selection is made, both simultaneously ("1" and "1") as well as either right or left independently ("1" and "0", "0" or "1"). Bit 11 to 14 are code bit to be used for chip selection.

For example, when KIC9162AN/AF, KIC9163AN/AF and KIC9164AN/AF are used simultaneously, if DATA, CK and ST terminals of each device are commonly connected, either one of KIC9162AN/AF, KIC9163AN/AF or KIC9164AN/AF can be selected by these code bit data.

The codes are set respectively as follows :

	C ₀	C ₁	C ₂	C ₃
KIC9162AN/AF	0	0	0	0
KIC9163AN/AF	1	0	0	0
KIC9164AN/AF	0	1	0	0

Note : As for KIC9162AN/AF, the switch consists of 7 circuits.
So the 8 bit must be used at level "0".

KIC9162AN/AF ~ KIC9164AN/AF

TIMING OF DATA, CK and ST

input data to the DATA, CK and ST terminals in the following timing conditions.

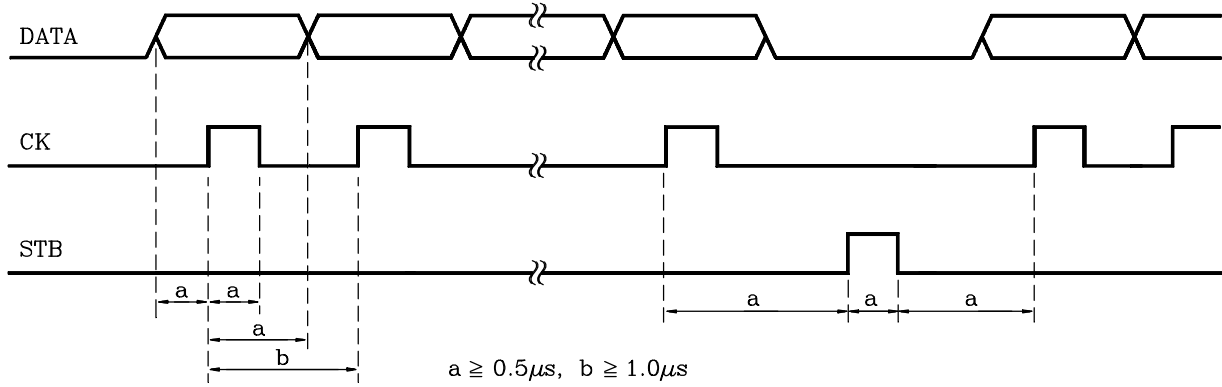

The data to the DATA terminal is input to the internal shift registers sequentially with synchronizing to the rise of the input to the CK terminal.

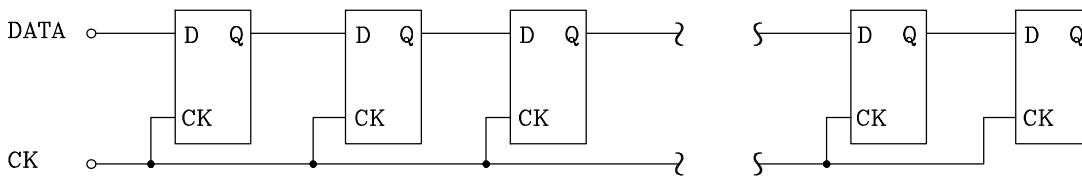
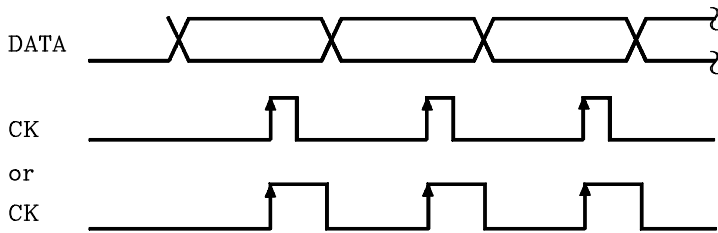

The input data are finally transferred to the latch circuit from the shift register by the ST signal, updating the previous data.

KIC9162AN/AF ~ KIC9164AN/AF

POWER SUPPLY CORRELATIONS

As the power supply sequence of analog switch part and control part, the analog part can be used by a dual power supply of (+) and (-), in which case, the control part operates in single power supply.

As the threshold level of the terminals of CK, DATA and ST are designed to low, CMOS microcomputers of 5V system can be easily interfaced in.

○ USE OF DUAL POWER SUPPLY

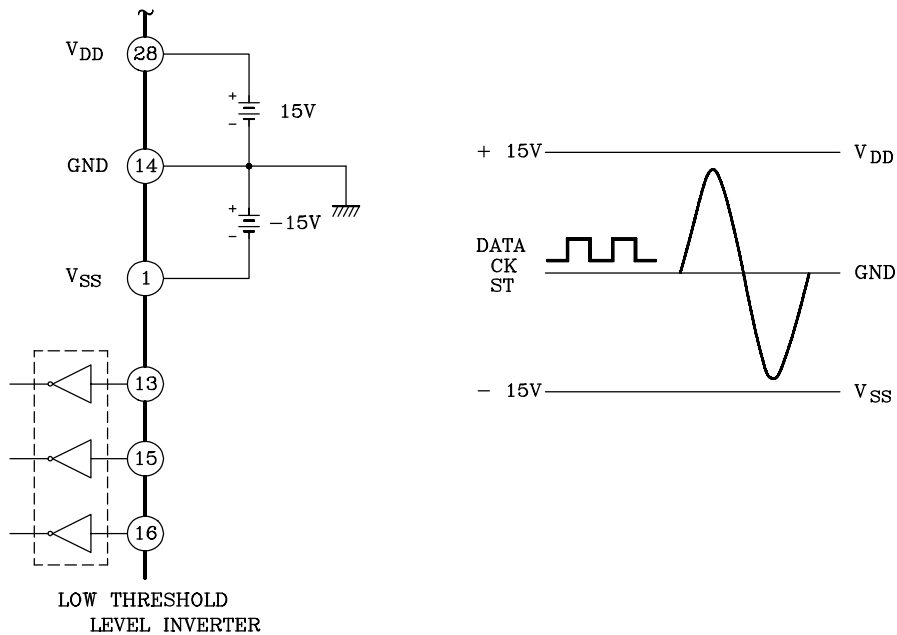

○ USE OF SINGLE POWER SUPPLY

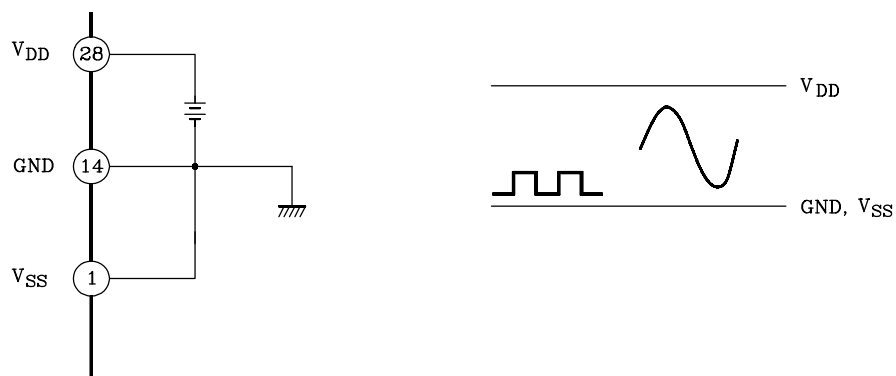

The operating voltage range of a single power supply use is half of a dual power supply use.

KIC9162AN/AF ~ KIC9164AN/AF

APPLICATION CIRCUIT

1. BACK-UP CIRCUIT

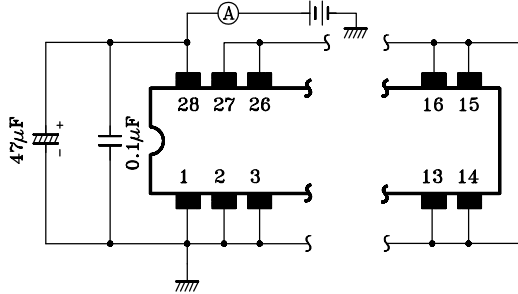

2. SWITCH-ON RESISTANCE

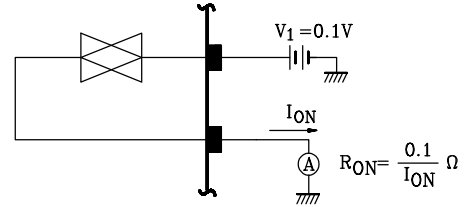

3. TOTAL HARMONIC DISTORTION

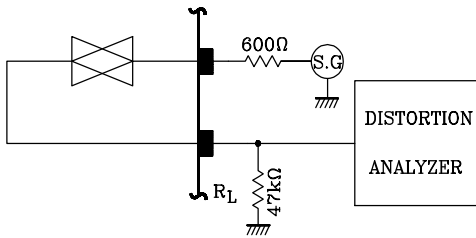

4. NOISE VOLTAGE

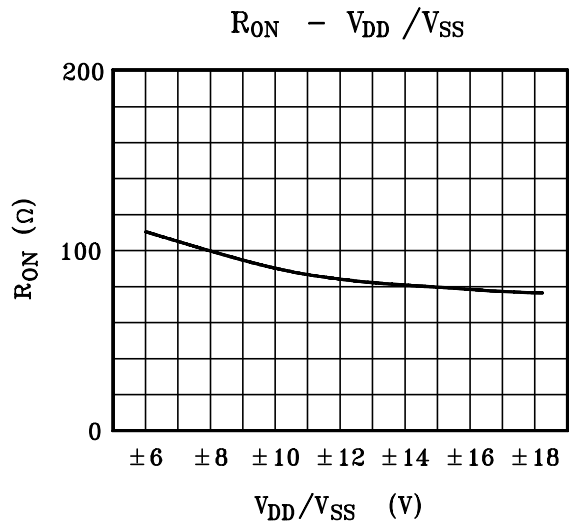
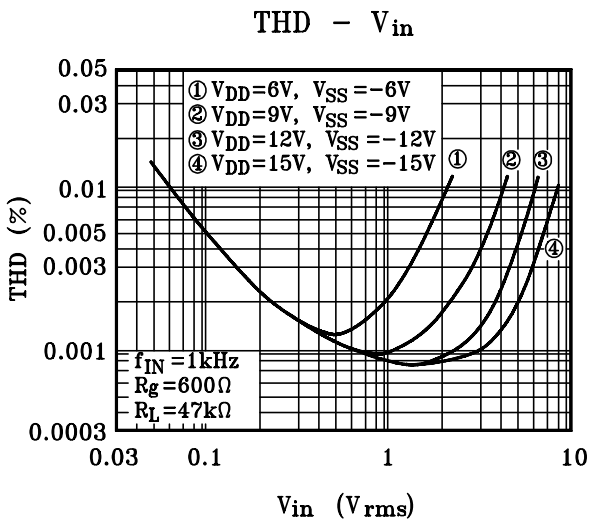
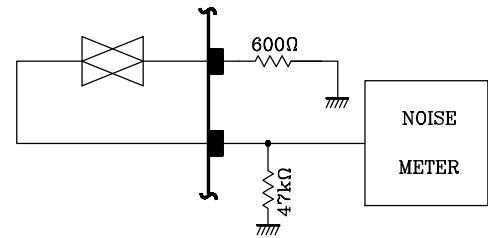

KIC9162AN/AF ~ KIC9164AN/AF

APPLICATION INFORMATION

1. AT POWER ON

When a voltage is applied, the analog switch is under an unstable condition.
Provide external measures such as muting until the data is finally set.

2. PROTECTION AGAINST EXCESS INPUT

When there is a possibility of inputting a excess voltage, more than $V_{DD}-V_{SS}$, to the analog switch, add a protective circuit as shown below :

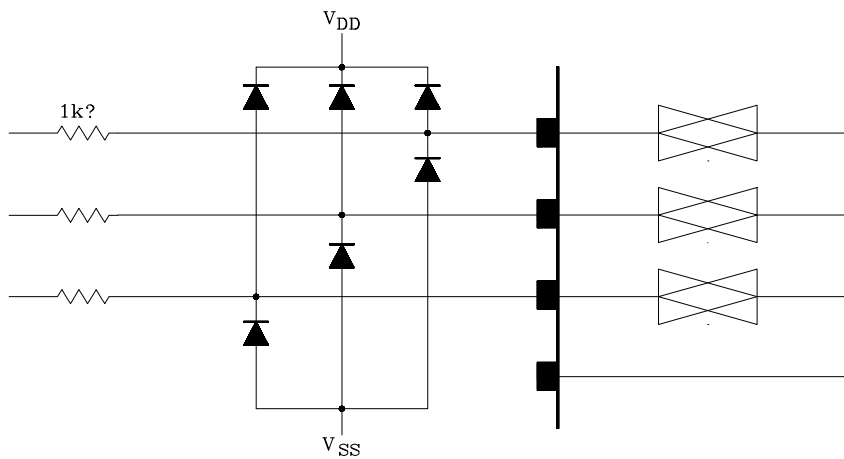

3. NOISE AT DATA TRANSFERRING

Some frequency of the CK signal may affect the analog switch and cause noises at data transferring.
CK signals should be at the frequency out of audio band as possible.