

### General Description

The Kawasaki KL5BUDV002 is a high performance device that transfers data between the USB2.0 high-speed BUS and the PCI 33MHz, 32 bit BUS. This device easily interfaces with our USB 2.0 transceivers, the KL5KUSB200 and KL5KUSB201. The KL5BUDV002 is an ideal solution to convert a PCI device to a USB2.0 interface with its HS\_SIE USB2.0 Transceiver interface, 4 sets of high-speed bulk packet size buffers, PCI interface and PCI master 2DMA channel support.

### Features

- 33MHz PCI interface
- 30MHz USB 2.0 SIE BUS for High-Speed SIE operation
- Double packet buffer - 512x2 HS, 64Bx2 FS
- Internal DMA operation between the High-Speed SIE and Double Buffer
- Interfaces with USB 2.0 PHY
- High-Speed chirp protocol
- High-Speed/Full-Speed compatibility
- USB basic operation and transaction control
- Up to 5 endpoints
- PCI interface for Target and Master (2 DMA) modes
- Page and Descriptor DMA Modes
- USB data access by PCI target or DMA
- 0.35u Std cell technology
- $V_{dd} = 3.3V$ ,  $T_a = 0\sim70^{\circ}C$
- 144 pin LQFP package (20 mm<sup>2</sup>)

### Block Diagram

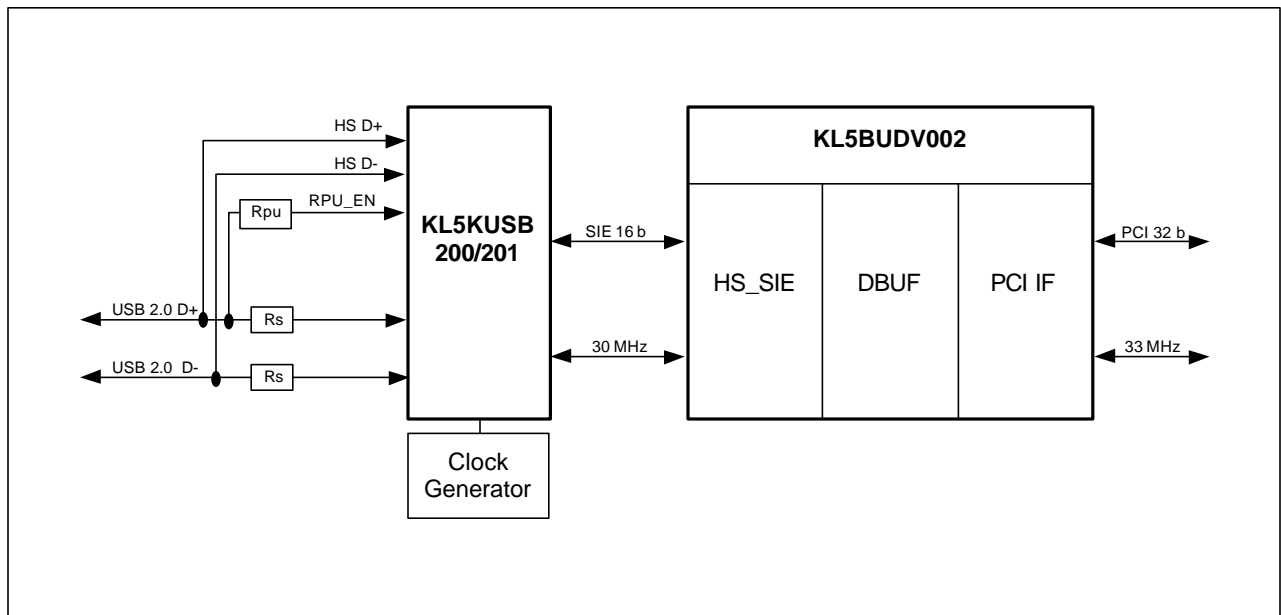

### Pin Diagram 144LQFP

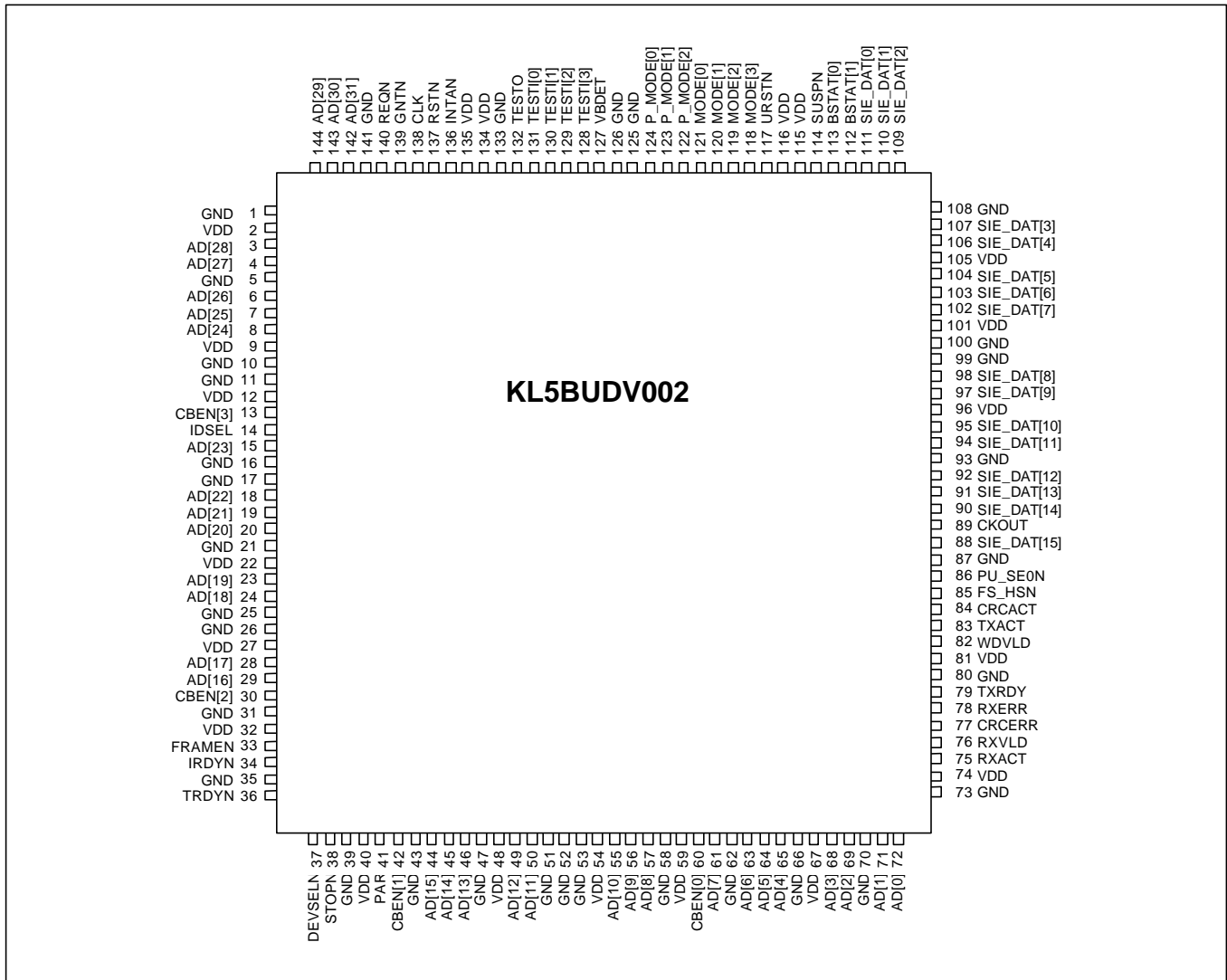

Kawasaki LSI assumes no responsibility or liability for (1) any errors or inaccuracies contained in the information herein and (2) the use of the information or a portion thereof in any application, including any claim for (a) copyright or patent infringement or (b) direct, indirect, special or consequential damages. There are no warranties extended or granted by this document. The information herein is subject to change without notice from Kawasaki LSI