

**Document Title****4M x 8 bit NAND Flash Memory****Revision History**

<b><u>Revision No.</u></b>	<b><u>History</u></b>	<b><u>Draft Date</u></b>	<b><u>Remark</u></b>
0.0	Data Sheet, 1997	April 10th 1997	
1.0	Data Sheet, 1998 1. Changed tBERS parameter : 5ms(Typ.) → 2ms(Typ.) 2. Removed reverse type package. 3. The 1st block(00h block address) is guaranteed to be a good block. 4. Changed AC parameters. tWH : 10ns(Min.) → 15ns(Min). tREH : 10ns(Min) → 15ns(Min).	April 10th 1998	
1.1	Data Sheet, 1998	July 14th 1998	Final

---

The attached datasheets are prepared and approved by SAMSUNG Electronics. SAMSUNG Electronics CO., LTD. reserve the right to change the specifications. SAMSUNG Electronics will evaluate and reply to your requests and questions about device. If you have any questions, please contact the SAMSUNG branch office near you.

---



## 4M x 8 Bit NAND Flash Memory

### FEATURES

- Single 3.3 volt Supply
- Organization
  - Memory Cell Array : (4M + 128K)bit x 8bit
  - Data Register : (512 + 16)bit x8bit
- Automatic Program and Erase
  - Page Program : (512 + 16)Byte
  - Block Erase : (8K + 256)Byte
  - Status Register
- 528-Byte Page Read Operation
  - Random Access : 10 μs(Max.)
  - Serial Page Access : 50ns(Min.)
- Fast Write Cycle Time
  - Program time : 250 μs(typ.)
  - Block Erase time : 2ms(typ.)
- Command/Address/Data Multiplexed I/O port
- Hardware Data Protection
  - Program/Erase Lockout During Power Transitions
- Reliable CMOS Floating-Gate Technology
  - Endurance : 1M Program/Erase Cycles
  - Data Retention : 10 years
- Command Register Operation
- 44(40) - Lead TSOP Type II (400mil / 0.8 mm pitch)
  - Forward Type

### GENERAL DESCRIPTION

The KM29V32000 is a 4M(4,194,304)x8bit NAND Flash Memory with a spare 128K(131,072)x8bit. Its NAND cell provides the most cost-effective solution for the solid state mass storage market. A program operation programs the 528-byte page in typically 250μs and an erase operation can be performed in typically 2ms on an 8K-byte block.

Data in the page can be read out at 50ns cycle time per byte. The I/O pins serve as the ports for address and data input/output as well as command inputs. The on-chip write controller automates all program and erase system functions, including pulse repetition, where required, and internal verify and margining of data. Even the write-intensive systems can take advantage of the KM29V32000 extended reliability of one million program/erase cycles by providing either ECC(Error Correction Code) or real time mapping-out algorithm. These algorithms have been implemented in many mass storage applications and also the spare 16 bytes of a page combined with the other 512 bytes can be utilized by system-level ECC.

The KM29V32000 is an optimum solution for large nonvolatile storage application such as solid state storage, digital voice recorder, digital still camera and other portable applications requiring nonvolatility.

### PIN CONFIGURATION

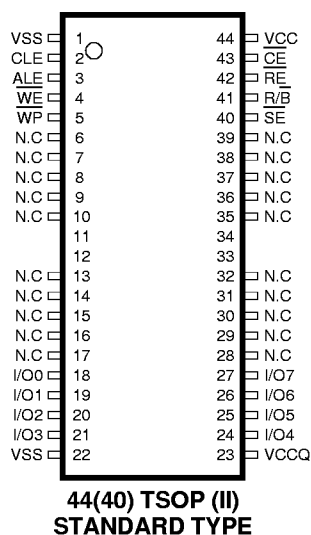

### PIN DESCRIPTION

Pin Name	Pin Function
I/O <sub>0</sub> ~ I/O <sub>7</sub>	Data Inputs/Outputs
CLE	Command Latch Enable
ALE	Address Latch Enable
$\overline{\text{CE}}$	Chip Enable
$\overline{\text{RE}}$	Read Enable
$\overline{\text{WE}}$	Write Enable
$\overline{\text{WP}}$	Write Protect
$\overline{\text{SE}}$	Spare area Enable
R/ $\overline{\text{B}}$	Ready/Busy output
Vcc	Power(+3.3V)
Vccq	Output Buffer Power(+3.3V or 5.0V)
Vss	Ground
N.C	No Connection

**NOTE :** Connect all Vcc, Vccq and Vss pins of each device to power supply outputs.  
Do not leave Vcc or Vss disconnected.

Figure 1. FUNCTIONAL BLOCK DIAGRAM

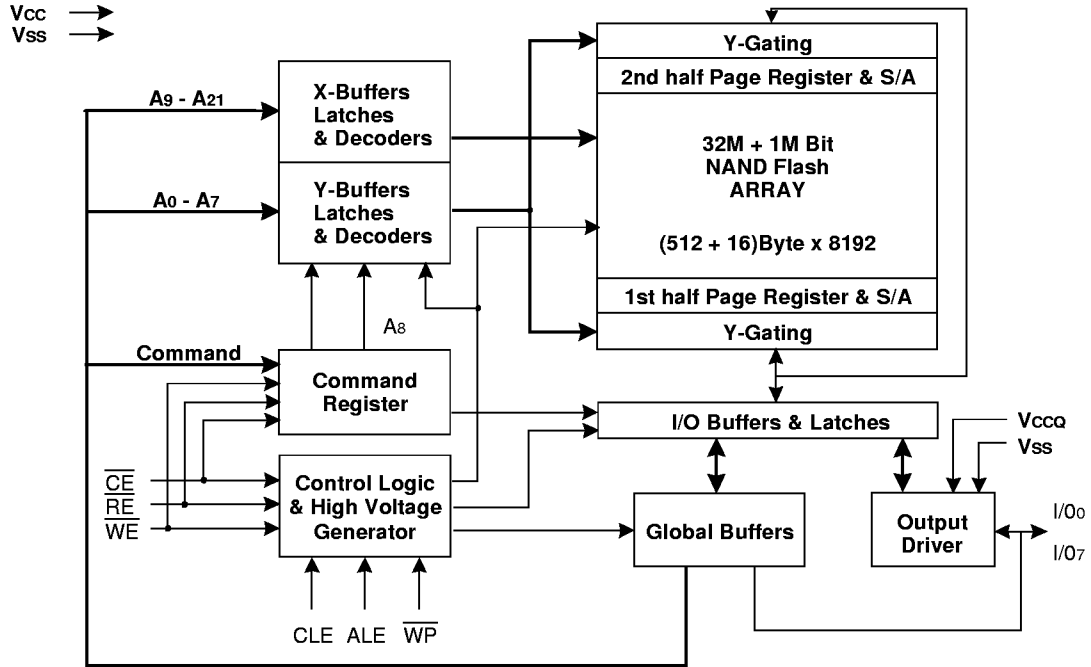
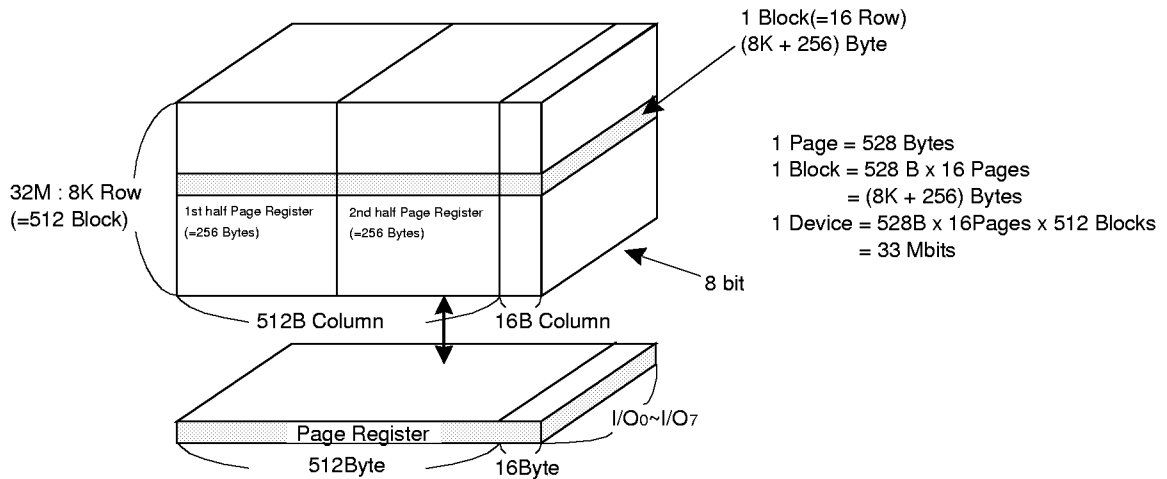

Figure 2. ARRAY ORGANIZATION



	I/O <sub>0</sub>	I/O <sub>1</sub>	I/O <sub>2</sub>	I/O <sub>3</sub>	I/O <sub>4</sub>	I/O <sub>5</sub>	I/O <sub>6</sub>	I/O <sub>7</sub>	
1st Cycle	A <sub>0</sub>	A <sub>1</sub>	A <sub>2</sub>	A <sub>3</sub>	A <sub>4</sub>	A <sub>5</sub>	A <sub>6</sub>	A <sub>7</sub>	Column Address
2nd Cycle	A <sub>9</sub>	A <sub>10</sub>	A <sub>11</sub>	A <sub>12</sub>	A <sub>13</sub>	A <sub>14</sub>	A <sub>15</sub>	A <sub>16</sub>	Row Address
3rd Cycle	A <sub>17</sub>	A <sub>18</sub>	A <sub>19</sub>	A <sub>20</sub>	A <sub>21</sub>	*X	*X	*X	(Page Address)

NOTE : Column Address : Starting Address of the Register.

00H Command(Read) : Defines the starting Address of the 1st half of the Register.

01H Command(Read) : Defines the starting Address of the 2nd half of the Register.

\* A<sub>8</sub> is initially set to "Low" or "High" by the 00H or 01H Command.

\* X can be High or Low.

**PRODUCT INTRODUCTION**

The KM29V32000 is a 33Mbit(34,603,008 bit) memory organized as 8192 rows by 528 columns. Spare sixteen columns are located from column address of 512 to 527. A 528-byte data register is connected to memory cell arrays accommodating data transfer between the I/O buffers and memory during page read and page program operations. The memory array is made up of 16 cells that are serially connected to form a NAND structure. Each of the 16 cells resides in a different page. A block consists of the 16 pages formed by one NAND structures, totaling 528 NAND structures of 16 cells. The array organization is shown in Figure 2. The program and read operations are executed on a page basis, while the erase operation is executed on block basis. The memory array consists of 512 separately or grouped erasable 8K-byte blocks. It indicates that the bit by bit erase operation is prohibited on the KM29V32000.

The KM29V32000 has addresses multiplexed into 8 I/O s. This scheme dramatically reduces pin counts and allows systems upgrades to future densities by maintaining consistency in system board design. Command, address and data are all written through the I/O s by bringing WE to low while CE is low. Data is latched on the rising edge of WE. Command Latch Enable(CLE) and Address Latch Enable(ALE) are used to multiplex command and address respectively, via the I/O pins. All commands require one bus cycle except for Block Erase command which requires two cycles : a cycle for erase-setup and another for erase-execution after block address loading. The 4M byte physical space requires 22 addresses, thereby requiring three cycles for byte-level addressing: column address, low row address and high row address, in that order. Page Read and Page Program need the same three address cycles following the required command input. In Block Erase operation, however, only the two row address cycles are used.

Device operations are selected by writing specific commands into the command register. Table 1 defines the specific commands of the KM29V32000.

**Table 1. COMMAND SETS**

Function	1st. Cycle	2nd. Cycle	Acceptable Command during Busy
Sequential Data Input	80h	-	
Read 1	00h/01h <sup>(1)</sup>	-	
Read 2	50h <sup>(2)</sup>	-	
Read ID	90h	-	
Reset	FFh	-	○
Page Program	10h	-	
Block Erase	60h	D0h	
Erase Suspend	B0h	-	○
Erase Resume	D0h	-	
Read Status	70h	-	○

**NOTE :** 1. The 00H command defines starting address of the 1st half of registers.  
 The 01H command defines starting address of the 2nd half of registers.  
 After data access on the 2nd half of register by the 01H command, the status pointer is automatically moved to the 1st half register(00H) on the next cycle.  
 2. The 50H command is valid only when the SE(pin 40) is low level.

## PIN DESCRIPTION

### Command Latch Enable(CLE)

The CLE input controls the path activation for commands sent to the command register. When active high, commands are latched into the command register through the I/O ports on the rising edge of the  $\overline{WE}$  signal.

### Address Latch Enable(ALE)

The ALE input controls the path activation for address and input data to the internal address/data register. Addresses are latched on the rising edge of  $\overline{WE}$  with ALE high, and input data is latched when ALE is low.

### Chip Enable( $\overline{CE}$ )

The  $\overline{CE}$  input is the device selection control. When  $\overline{CE}$  goes high during a read operation the device is returned to standby mode. However, when the device is in the busy state during program or erase,  $\overline{CE}$  high is ignored, and does not return the device to standby mode.

### Write Enable( $\overline{WE}$ )

The  $\overline{WE}$  input controls writes to the I/O port. Commands, address and data are latched on the rising edge of the  $\overline{WE}$  pulse.

### Read Enable( $\overline{RE}$ )

The  $\overline{RE}$  input is the serial data-out control, and when active drives the data onto the I/O bus. Data is valid  $t_{REA}$  after the falling edge of  $\overline{RE}$  which also increments the internal column address counter by one.

### Spare Area Enable( $\overline{SE}$ )

The  $\overline{SE}$  input controls the spare area selection when  $\overline{SE}$  is high, the device is deselected the spare area during Read1, Sequential data input and page Program.

### I/O Port : I/O<sub>0</sub>~I/O<sub>7</sub>

The I/O pins are used to input command, address and data, and to output data during read operations. The I/O pins float to high- $z$  when the chip is deselected or when the outputs are disabled.

### Write Protect( $\overline{WP}$ )

The  $\overline{WP}$  pin provides inadvertent write/erase protection during power transitions. The internal high voltage generator is reset when the  $\overline{WP}$  pin is active low.

### Ready/Busy( $\overline{R/B}$ )

The R/B output indicates the status of the device operation. When low, it indicates that a program, erase or random read operation is in process and returns to high state upon completion. It is an open drain output and does not float to high- $z$  condition when the chip is deselected or when outputs are disabled.

### Power Line(V<sub>CC</sub> & V<sub>CCQ</sub>)

The V<sub>CCQ</sub> is the power supply for I/O interface logic. It is electrically isolated from main power line(V<sub>CC</sub>=3.3V) for supporting 5V tolerant I/O with 5V power supply at V<sub>CCQ</sub>.

## ABSOLUTE MAXIMUM RATINGS

Parameter		Symbol	Rating	Unit
Voltage on any pin relative to V <sub>SS</sub>		V <sub>IN</sub>	-0.6 to +6.0	V
Temperature Under Bias	KM29V32000T	T <sub>BIAS</sub>	-10 to +125	°C
	KM29V32000IT		-40 to +125	
Storage Temperature		T <sub>STG</sub>	-65 to +150	°C
Short Circuit Output Current		I <sub>OS</sub>	5	mA

**NOTE :**

- Minimum DC voltage is -0.3V on input/output pins. During transitions, this level may undershoot to -2.0V for periods <30ns. Maximum DC voltage on input/output pins is V<sub>CCQ</sub>+0.3V which, during transitions, may overshoot to V<sub>CC</sub>+2.0V for periods <20ns.
- Permanent device damage may occur if ABSOLUTE MAXIMUM RATINGS are exceeded. Functional operation should be restricted to the conditions as detailed in the operational sections of this data sheet. Exposure to absolute maximum rating conditions for extended periods may affect reliability.

## RECOMMENDED OPERATING CONDITIONS

(Voltage reference to GND, KM29V32000T: T<sub>A</sub>=0 to 70°C, KM29V32000IT: T<sub>A</sub>=-40 to 85°C)

Parameter	Symbol	Min	Typ.	Max	Unit
Supply Voltage	V <sub>CC</sub>	3.0	3.3	3.6	V
Supply Voltage	V <sub>CCQ</sub> <sup>1)</sup>	3.0	-	5.5	V
Supply Voltage	V <sub>SS</sub>	0	0	0	V

**NOTE :**

## DC AND OPERATING CHARACTERISTICS (Recommended operating conditions otherwise noted.)

Parameter		Symbol	Test Conditions	Min	Typ	Max	Unit
Operating Current	Sequential Read	I <sub>CC1</sub>	t <sub>cycle</sub> =50ns, $\overline{CE}=V_{IL}, I_{OUT}=0mA$	-	10	20	mA
	Command, Address Input	I <sub>CC3</sub>	t <sub>cycle</sub> =50ns	-	10	20	mA
	Data Input	I <sub>CC4</sub>	-	-	10	20	mA
	Program	I <sub>CC6</sub>	-	-	10	20	mA
	Erase	I <sub>CC7</sub>	-	-	10	20	mA
Stand-by Current(TTL)	I <sub>SB1</sub>		$\overline{CE}=V_{IH}, \overline{WP}=\overline{SE}=0V/V_{CC}$	-	-	1	mA
Stand-by Current(CMOS)	I <sub>SB2</sub>		$\overline{CE}=V_{CC}-0.2, \overline{WP}=\overline{SE}=0V/V_{CC}$	-	10	50	µA
Input Leakage Current	I <sub>LI</sub>		V <sub>IN</sub> =0 to 3.6V	-	-	±10	µA
Output Leakage Current	I <sub>LO</sub>		V <sub>OUT</sub> =0 to 3.6V	-	-	±10	µA
Input High Voltage	V <sub>IH</sub>		I/O pins	2.0	-	V <sub>CCQ</sub> +0.3	V
			Except I/O pins	2.0	-	V <sub>CC</sub> +0.3	
Input Low Voltage, All inputs	V <sub>IL</sub>		-	-0.3	-	0.8	
Output High Voltage Level	V <sub>OH</sub>		I <sub>OH</sub> =-400µA	2.4	-	-	
Output Low Voltage Level	V <sub>OL</sub>		I <sub>OL</sub> =2.1mA	-	-	0.4	
Output Low Current(R/ $\overline{B}$ )	I <sub>OL</sub> (R/ $\overline{B}$ )		V <sub>OL</sub> =0.4V	8	10	-	mA

# KM29V32000T, KM29V32000IT

# FLASH MEMORY

## VALID BLOCK

Parameter	Symbol	Min	Typ.	Max	Unit
Valid Block Number	NVB	502	508	511	Blocks

### NOTE :

1. The KM29V32000 may or may not include bad blocks. Bad blocks are defined as blocks that contain one or more bad bits. Do not try to access these bad blocks for program and erase. The Minimum valid blocks are guaranteed for 10 years data retention or 1M program erase cyclin g. (Refer to the attached technical notes)
2. The 1st block, which is placed on 00h block address, is guaranteed to be a good block

## AC TEST CONDITION

(KM29V32000T:TA=0 to 70°C, KM29V32000IT:TA=-40 to 85°C, VCC=3.3V±10% unless otherwise noted)

Parameter	Value
Input Pulse Levels	0.4V to 2.4V
Input Rise and Fall Times	5ns
Input and Output Timing Levels	0.8V and 2.0V
Output Load	1 TTL GATE and CL=100pF

## CAPACITANCE (TA=25°C, VCC=3.3V, f=1.0MHz)

Item	Symbol	Test Condition	Min	Max	Unit
Input/Output Capacitance	C <sub>I/O</sub>	V <sub>IL</sub> =0V	-	10	pF
Input Capacitance	C <sub>IN</sub>	V <sub>IN</sub> =0V	-	10	pF

NOTE : Capacitance is periodically sampled and not 100% tested.

## MODE SELECTION

CLE	ALE	CE	WE	RE	SE	WP	Mode	
H	L	L		H	X	X	Read Mode	Command Input
L	H	L		H	X	X		Address Input(3clock)
H	L	L		H	X	H	Write Mode	Command Input
L	H	L		H	X	H		Address Input(3clock)
L	L	L		H	L/H <sup>(3)</sup>	H	Data Input	
L	L	L	H		L/H <sup>(3)</sup>	X	Sequential Read & Data Output	
L	L	L	H	H	L/H <sup>(3)</sup>	X	During Read(Busy)	
X	X	X	X	X	L/H <sup>(3)</sup>	H	During Program(Busy)	
X	X	X	X	X	X	H	During Erase(Busy)	
X	X <sup>(1)</sup>	X	X	X	X	L	Write Protect	
X	X	H	X	X	0V/V <sub>CC</sub> <sup>(2)</sup>	0V/V <sub>CC</sub> <sup>(2)</sup>	Stand-by	

NOTE : 1. X can be V<sub>IL</sub> or V<sub>IH</sub>

2. WP should be biased to CMOS high or CMOS low for standby.

3. When SE is high, spare area is deselected.

## Program/Erase Characteristics

Parameter	Symbol	Min	Typ	Max	Unit
Program Time	t <sub>PROG</sub>	-	0.25	1.5	ms
Number of Partial Program Cycles in the Same Page	Nop	-	-	10	cycles
Block Erase Time	t <sub>BERS</sub>	-	2	10	ms



**AC Timing Characteristics for Command / Address / Data Input**

Parameter	Symbol	Min	Max	Unit
CLE Set-up Time	tCLS	0	-	ns
CLE Hold Time	tCLH	10	-	ns
$\overline{\text{CE}}$ Setup Time	tCS	0	-	ns
$\overline{\text{CE}}$ Hold Time	tCH	10	-	ns
$\overline{\text{WE}}$ Pulse Width	tWP	25	-	ns
ALE Setup Time	tALS	0	-	ns
ALE Hold Time	tALH	10	-	ns
Data Setup Time	tDS	20	-	ns
Data Hold Time	tDH	10	-	ns
Write Cycle Time	tWC	50	-	ns
$\overline{\text{WE}}$ High Hold Time	tWH	15	-	ns

**AC Characteristics for Operation**

Parameter	Symbol	Min	Max	Unit
Data Transfer from Cell to Register	tR	-	10	$\mu\text{s}$
ALE to $\overline{\text{RE}}$ Delay(read ID)	tAR1	150	-	ns
ALE to $\overline{\text{RE}}$ Delay(Read cycle)	tAR2	50	-	ns
$\overline{\text{CE}}$ to $\overline{\text{RE}}$ Delay(ID read)	tCR	100	-	ns
Ready to $\overline{\text{RE}}$ Low	tRR	20	-	ns
$\overline{\text{RE}}$ Pulse Width	tRP	30	-	ns
$\overline{\text{WE}}$ High to Busy	tWB	-	100	ns
Read Cycle Time	tRC	50	-	ns
$\overline{\text{RE}}$ Access Time	tREA	-	35	ns
$\overline{\text{RE}}$ High to Output Hi-Z	tRHZ	15	30	ns
$\overline{\text{CE}}$ High to Output Hi-Z	tCHZ	-	20	ns
$\overline{\text{RE}}$ High Hold Time	tREH	15	-	ns
Output Hi-Z to $\overline{\text{RE}}$ Low	tIR	0	-	ns
Last RE High to Busy(at sequential read)	tRB	-	100	ns
$\overline{\text{CE}}$ High to Ready(in case of interception by $\overline{\text{CE}}$ at read) <sup>(1)</sup>	tCRY	-	50 +tr(R/ $\overline{\text{B}}$ ) <sup>(2)</sup>	ns
$\overline{\text{CE}}$ High Hold Time(at the last serial read) <sup>(3)</sup>	tCEH	100	-	ns
$\overline{\text{RE}}$ Low to Status Output	tRSTO	-	35	ns
$\overline{\text{CE}}$ Low to Status Output	tCSTO	-	45	ns
$\overline{\text{RE}}$ High to $\overline{\text{WE}}$ Low	tRHW	0	-	ns
$\overline{\text{WE}}$ High to $\overline{\text{RE}}$ Low	tWHR	60	-	ns
Erase Suspend Input to Ready	tSR	-	500	$\mu\text{s}$
$\overline{\text{RE}}$ access time(Read ID)	tREADID	-	35	ns
Device Resetting Time (Read/Program/Erase/after erase suspend)	tRST	-	5/10/500/5	$\mu\text{s}$

**NOTE** : 1. If  $\overline{\text{CE}}$  goes high within 30ns after the rising edge of the last  $\overline{\text{RE}}$ , R/ $\overline{\text{B}}$  will not return to Vol.

2. The time to Ready depends on the value of the pull-up resistor tied R/ $\overline{\text{B}}$  pin.

3. To break the sequential read cycle,  $\overline{\text{CE}}$  must be held high for longer time than tCEH.



**KM29V32000 Technical Notes**

**INVALID BLOCKS**

The KM29V32000 Flash device may or may not contain up to 10 invalid blocks. Invalid blocks are defined as blocks that contain one or more invalid bits. Typically, an invalid block will contain a single bad bit. Devices with invalid block(s) have the same quality levels as devices with all valid blocks and have the same AC and DC characteristics. An invalid block(s) does not affect the performance of valid block(s) because it is isolated from the bit line and the common source line by a select transistor. The system design must be able to mask out the invalid block(s) via address mapping. The 1st block of the KM29V32000, however, is fully guaranteed to be a good block.

**Identifying Invalid Block(s) in the KM29V32000**

All device locations are erased(FFh) prior to shipping. Device with invalid Block(s) will be randomly written with 00h data within the first or second page in the invalid Block(s). This page may or may not contain the invalid cell(s). The 00h data just marks the block(s) that contains the invalid cell(s). A system that can utilize these devices must be able to recognize invalid block(s) via the following suggested flow chart (Figure 1).

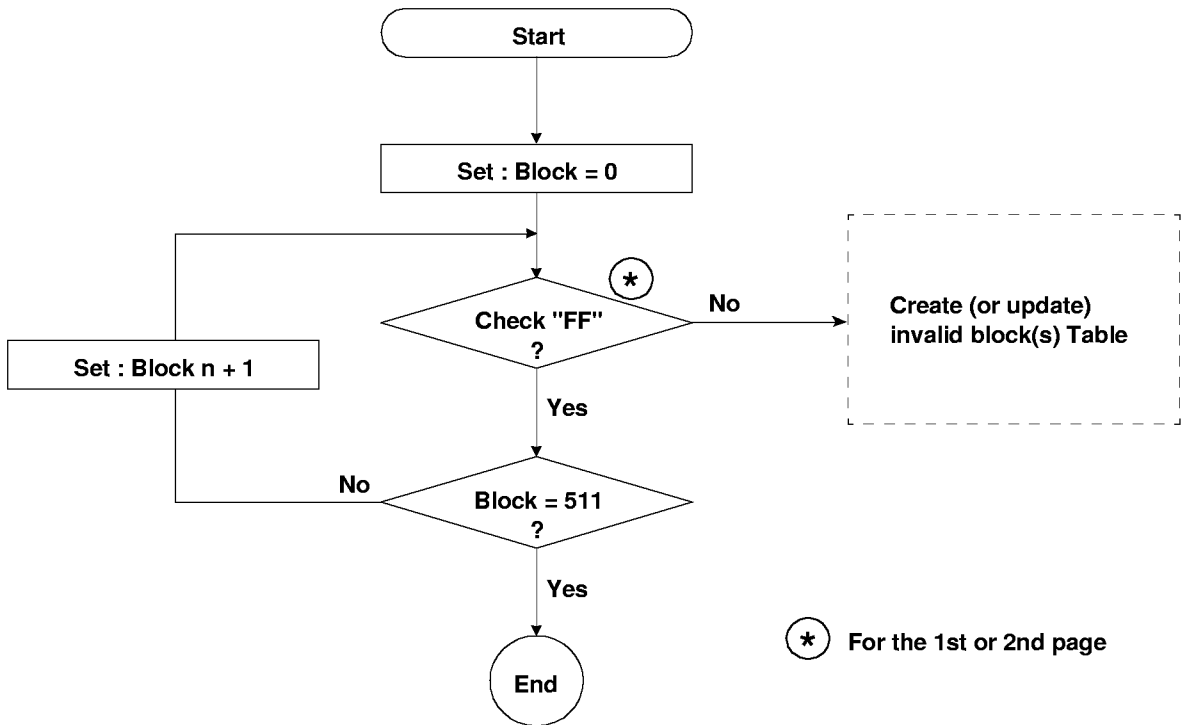

Figure 1. Flow chart to create invalid block table.

***KM29V32000 Technical Notes (Continued)***

**Error in program or erase operation**

The device may fail during a program or erase operation.

The following possible failure modes should be considered when implementing a highly reliable system.

Failure Mode		Detection and Countermeasure sequence
Block	Erase Failure	Status Read after Erase --> Block Replacement
Page	Program Failure	Status Read after Program --> Block Replacement
Single Bit	Program Failure ("1" --> "0")	Block Verify after Program --> Retry or ECC

**ECC** : Error Correcting Code --> Hamming Code etc.  
 Example) 1bit correction & 2bit detection

**Block Replacement**

**During Program operation ;**

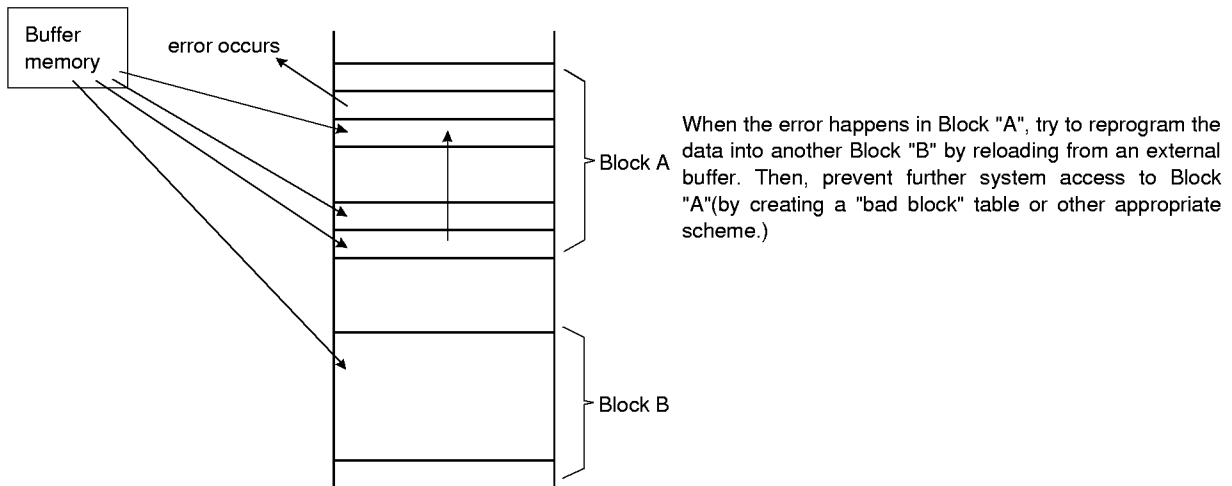

**During Erase operation ;**

When the error occurs after an erase operation, prevent future accesses to this bad block (again by creating a table within the system or other appropriate scheme.)

## Pointer Operation of KM29V32000

The KM29V32000 has three read modes to set the destination of the pointer. The pointer is set to "A" area by the "00h" command, to "B" area by the "01" command, and to "C" area by the "50h" command. Table 1 shows the destination of the pointer, and figure 2 shows the block diagram of its operations.

**Table 1. Destination of the pointer**

Command	Pointer position	Area
00H	0 ~ 255 byte	1st half array(A)
01H	256 ~ 511 byte	2nd half array(B)
50H	512 ~ 527 byte	spare array(C)

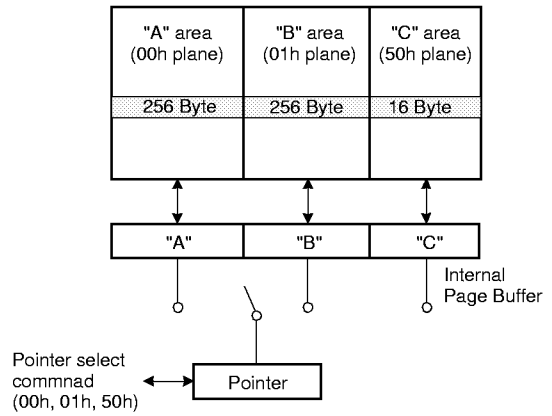

**Figure 2. Block diagram of pointer Operation**

## Example of Pointer Operation programming

### (1) "A" area program

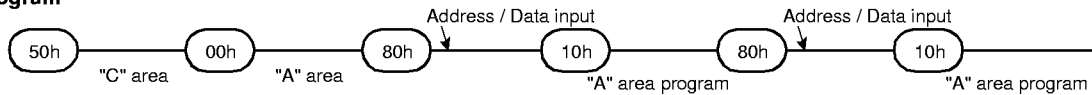

### (2) "B" area program

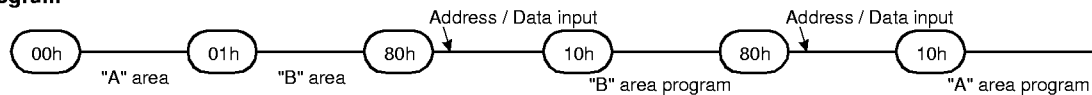

### (3) "C" area program

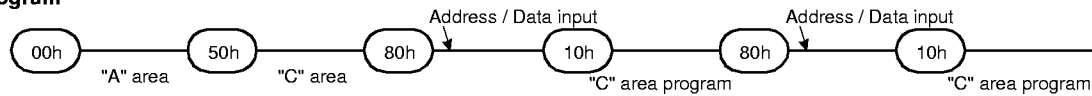
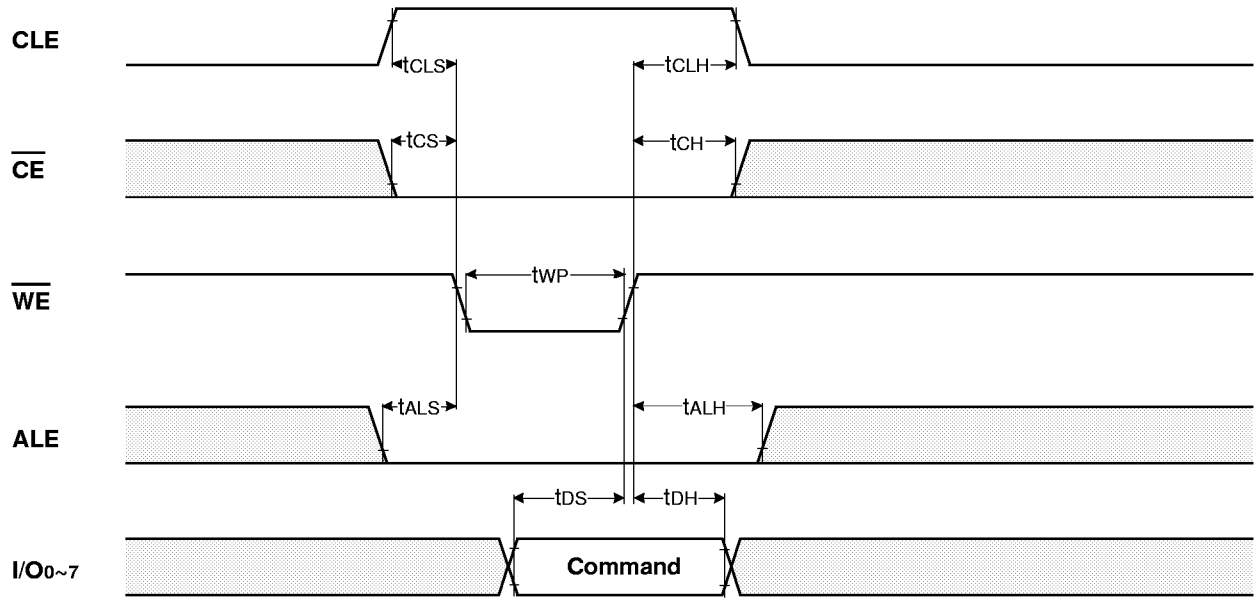

**Table 2. Pointer Status after each operation**

Operation	Pointer status after operation
Program/Erase	With previous 00H, Device is set to 00H Plane With previous 01H, Device is set to 00H Plane* With previous 50H, Device is set to 50H Plane
Reset	"00h" Plane("A" area)
Power up	"00h" Plane("A" area)

\* 01H command is valid just one time when it is used as a pointer for program/erase.

\* Command Latch Cycle



\* Address Latch Cycle

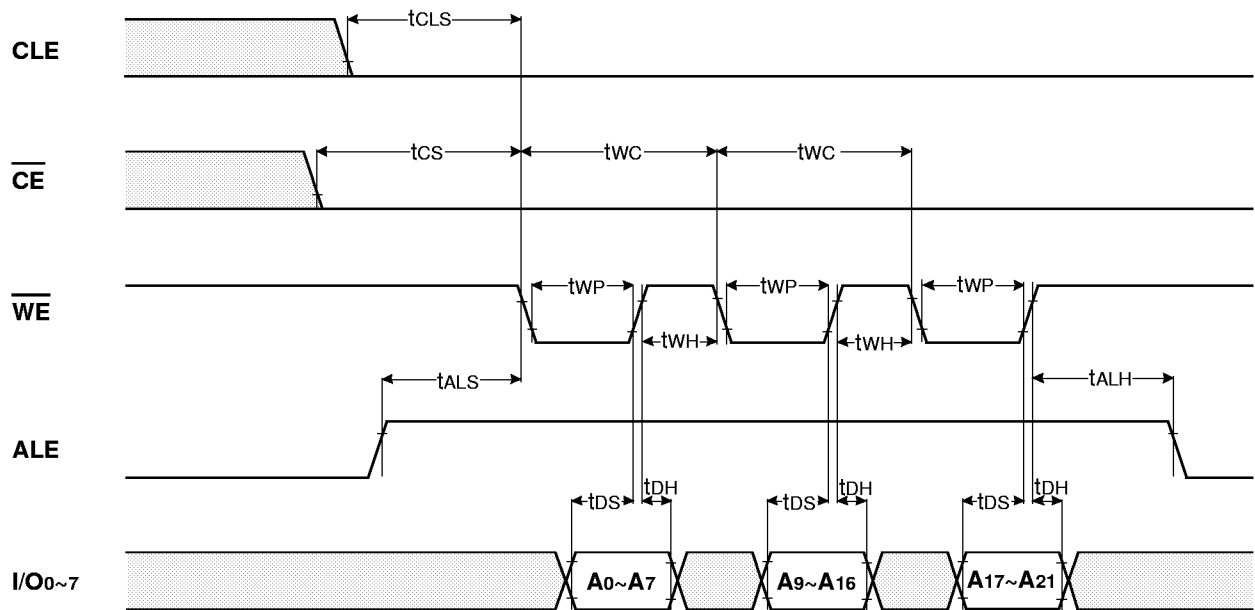

\* Input Data Latch Cycle

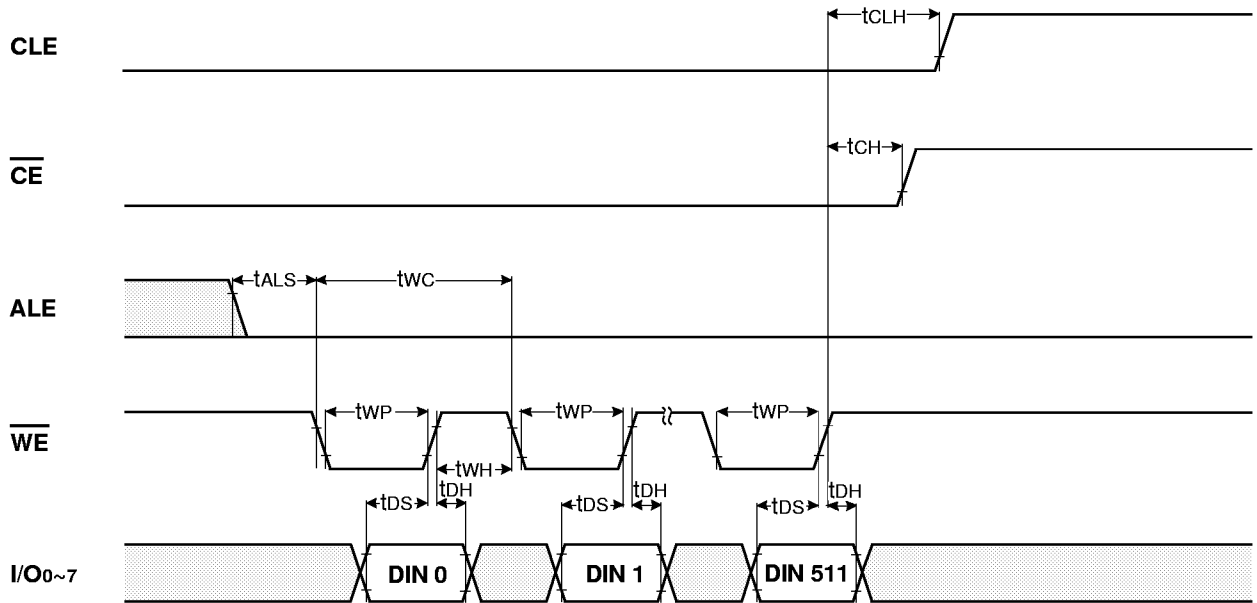

\* Sequential Out Cycle after Read (CLE=L, WE=H, ALE=L)

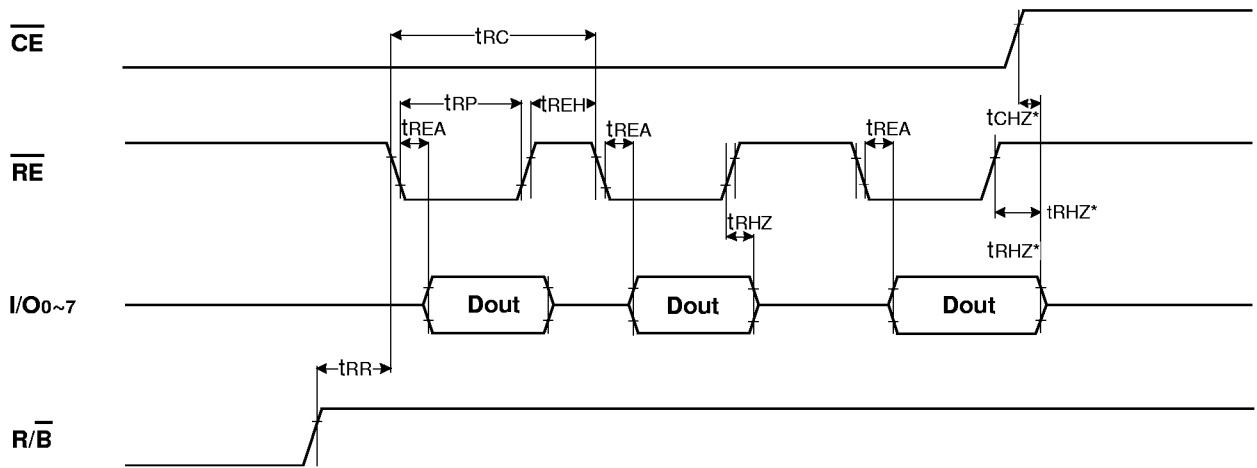

\* Status Read Cycle

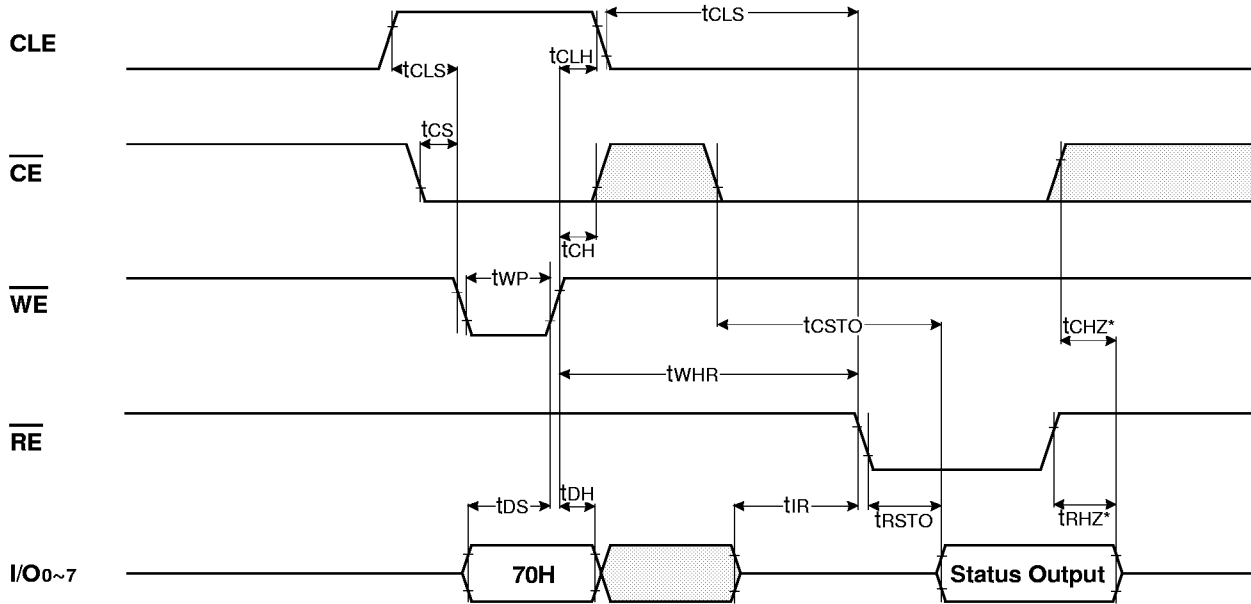

NOTES : Transition is measured  $\pm 200\text{mV}$  from steady state voltage with load.  
This parameter is sampled and not 100% tested.

READ1 OPERATION (READ ONE PAGE)

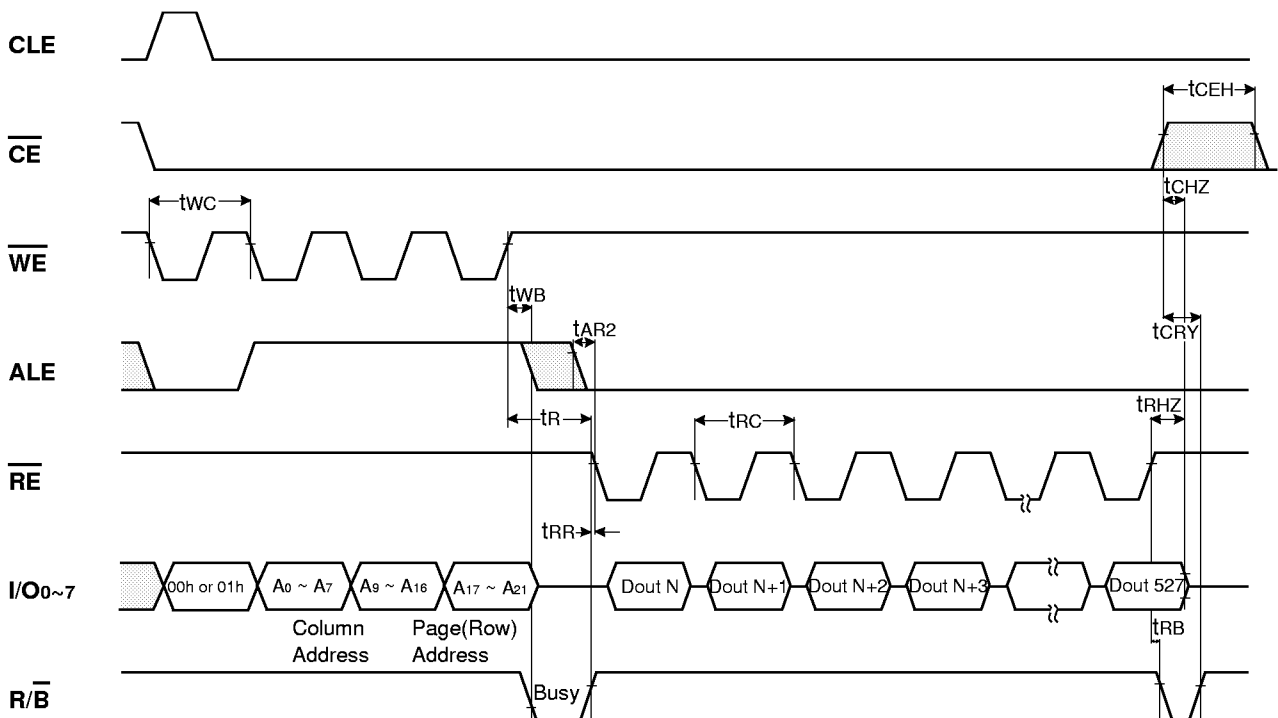

READ1 OPERATION (INTERCEPTED BY  $\overline{CE}$ )

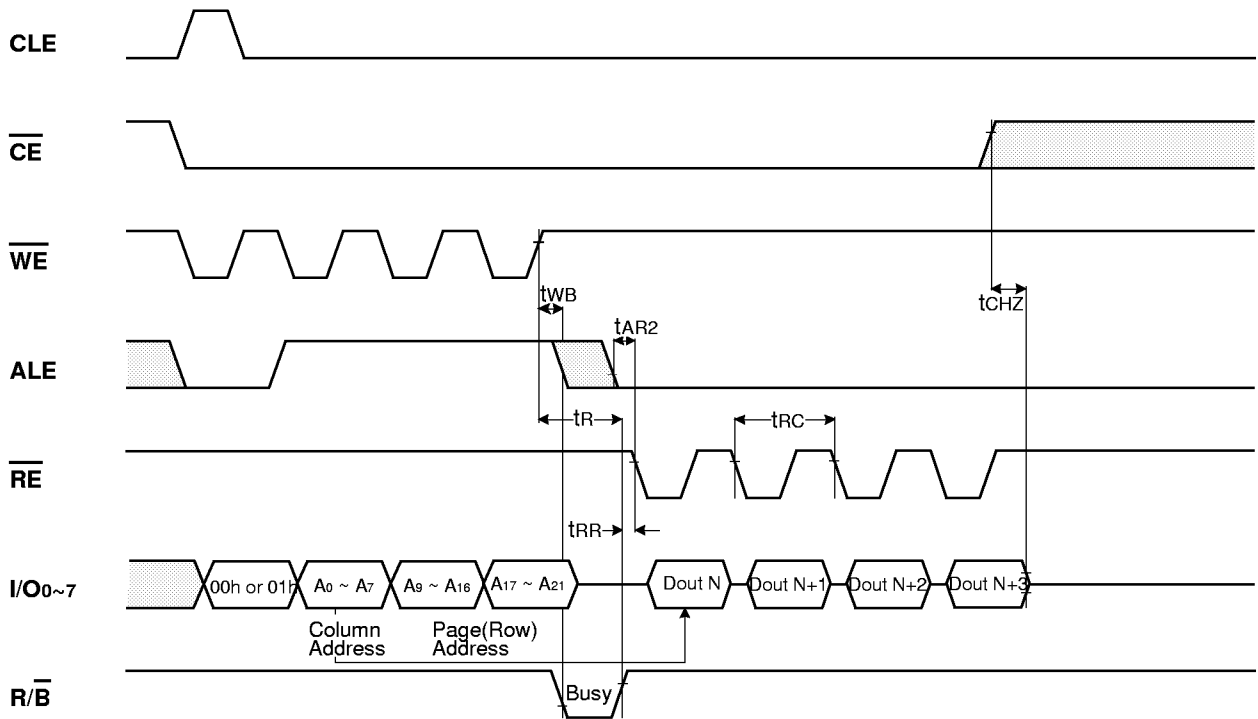

READ2 OPERATION (READ ONE PAGE)

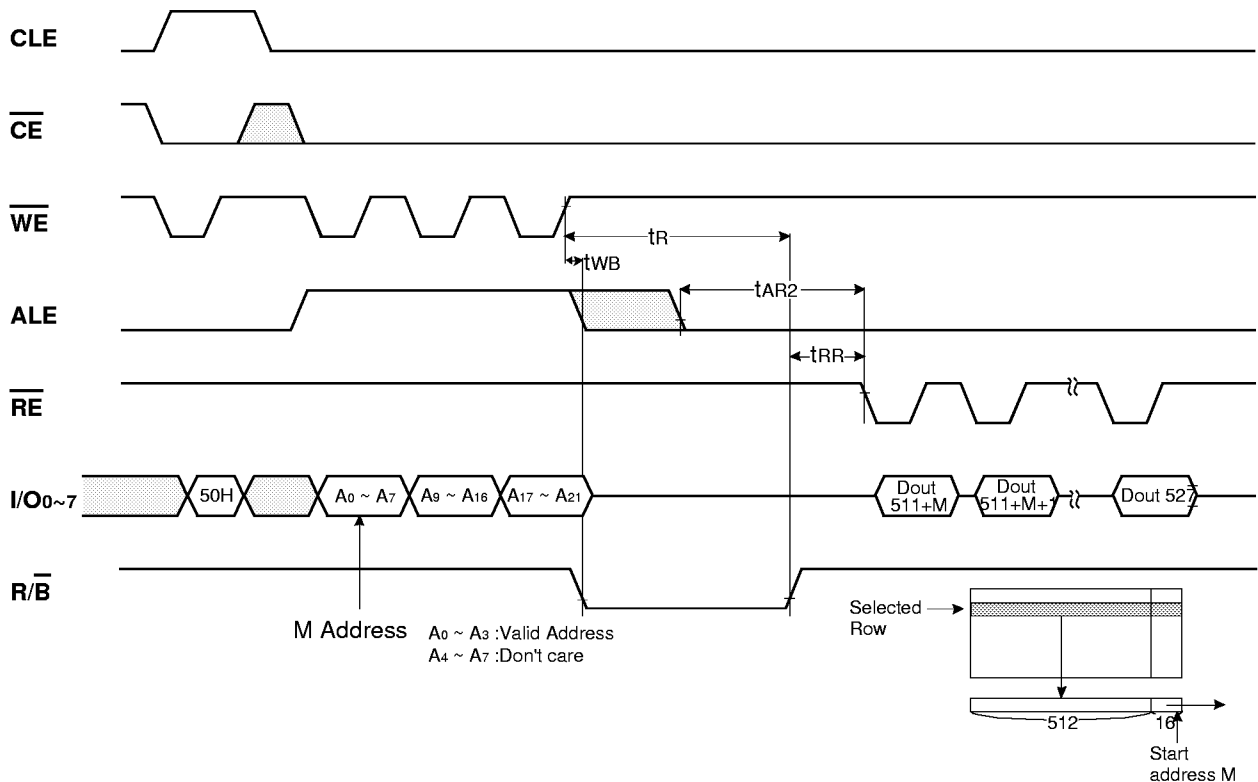

SEQUENTIAL ROW READ OPERATION

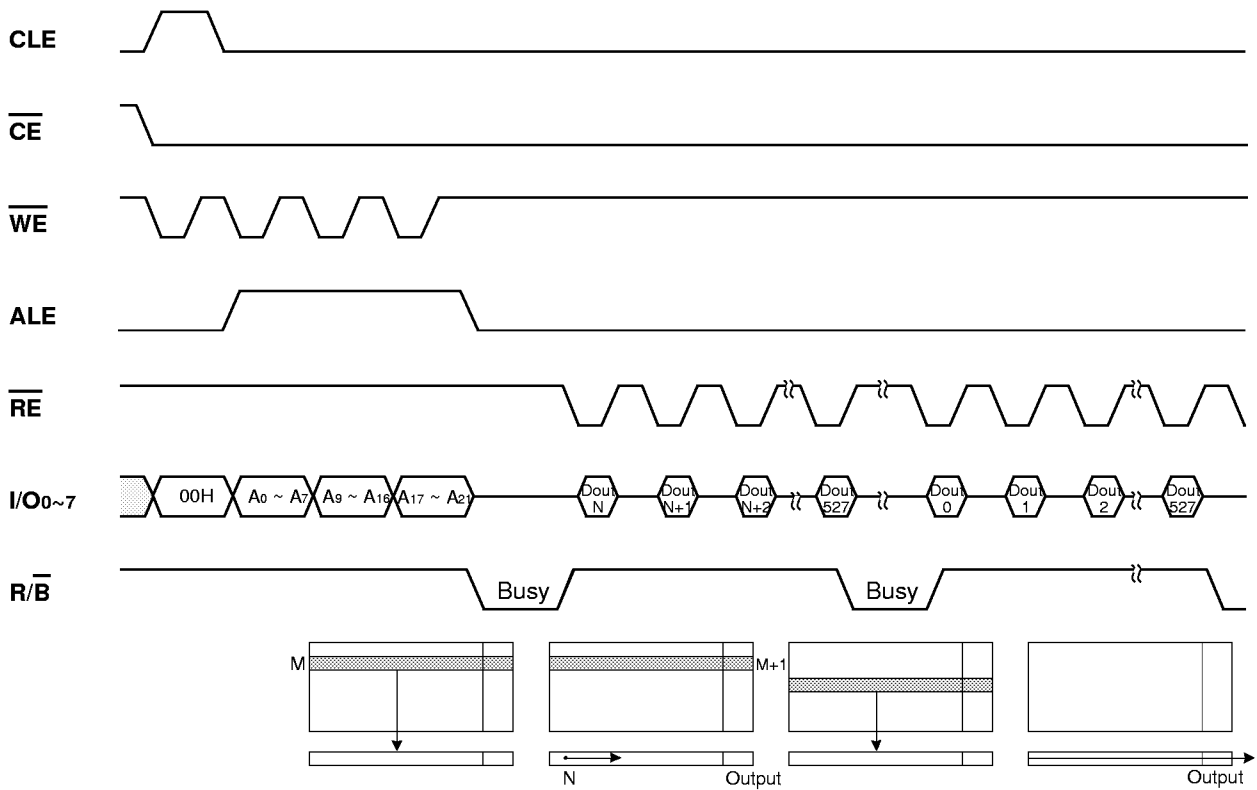

PAGE PROGRAM OPERATION

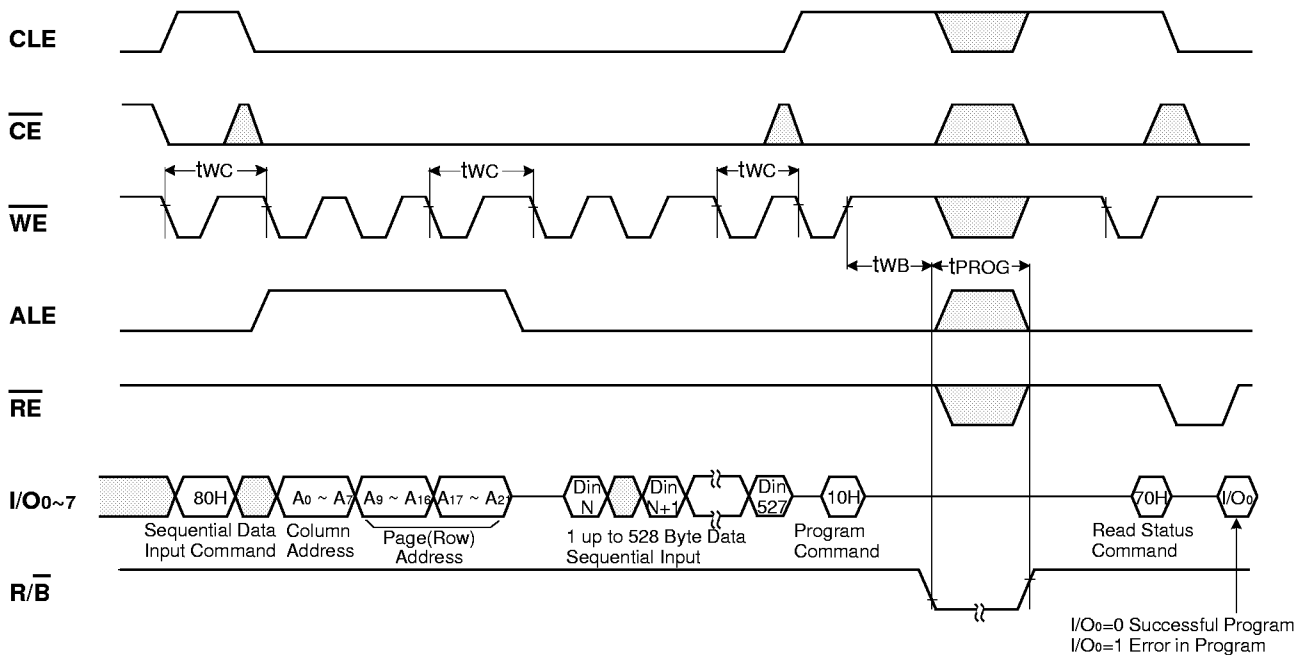



BLOCK ERASE OPERATION (ERASE ONE BLOCK)

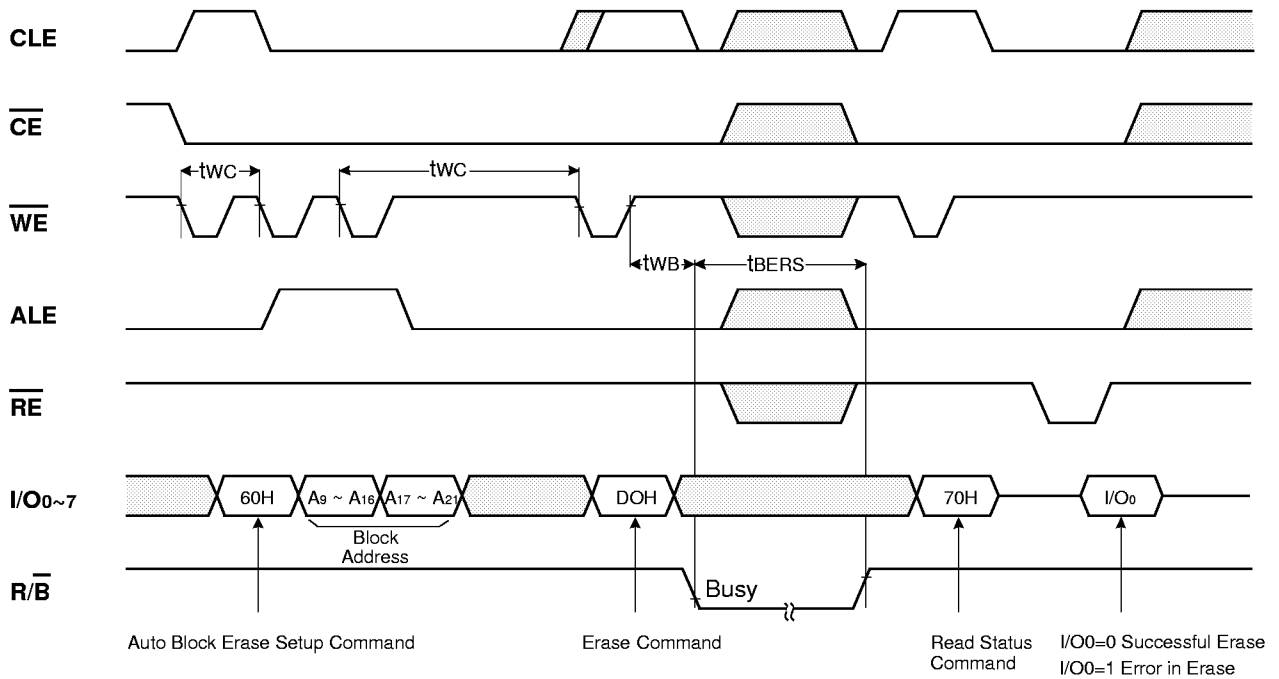

SUSPEND & RESUME OPERATION DURING BLOCK ERASE

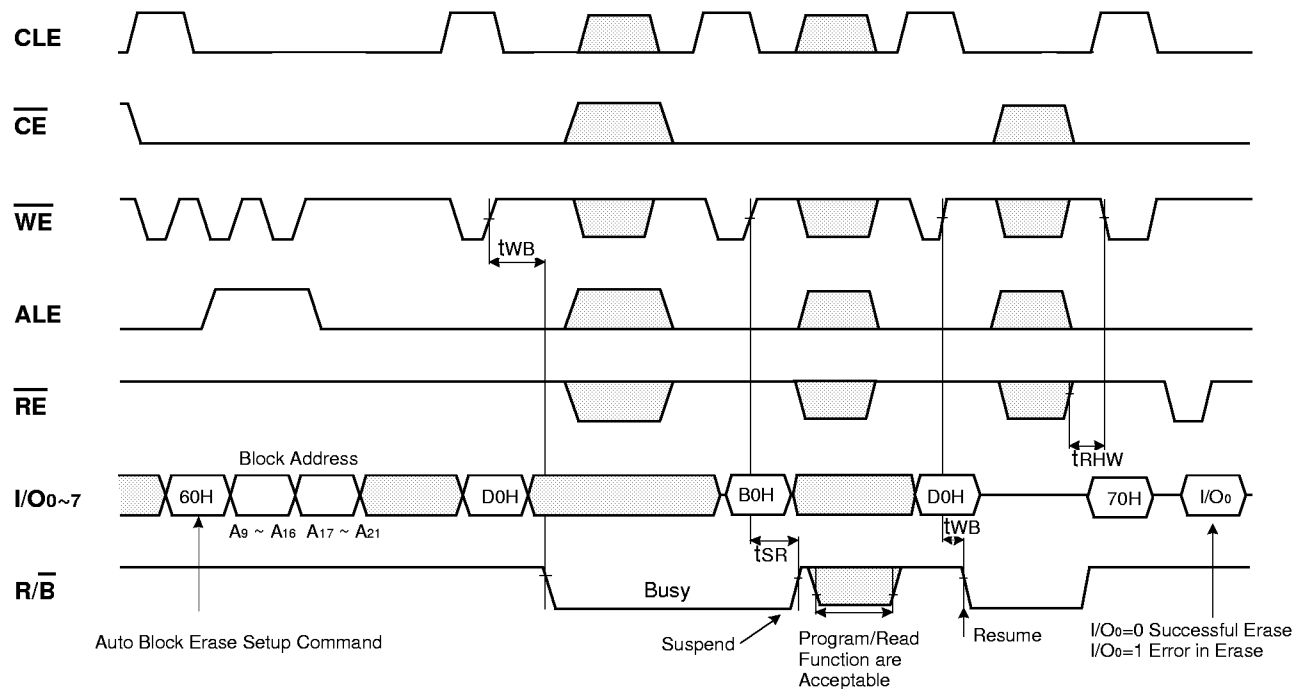

MANUFACTURE & DEVICE ID READ OPERATION

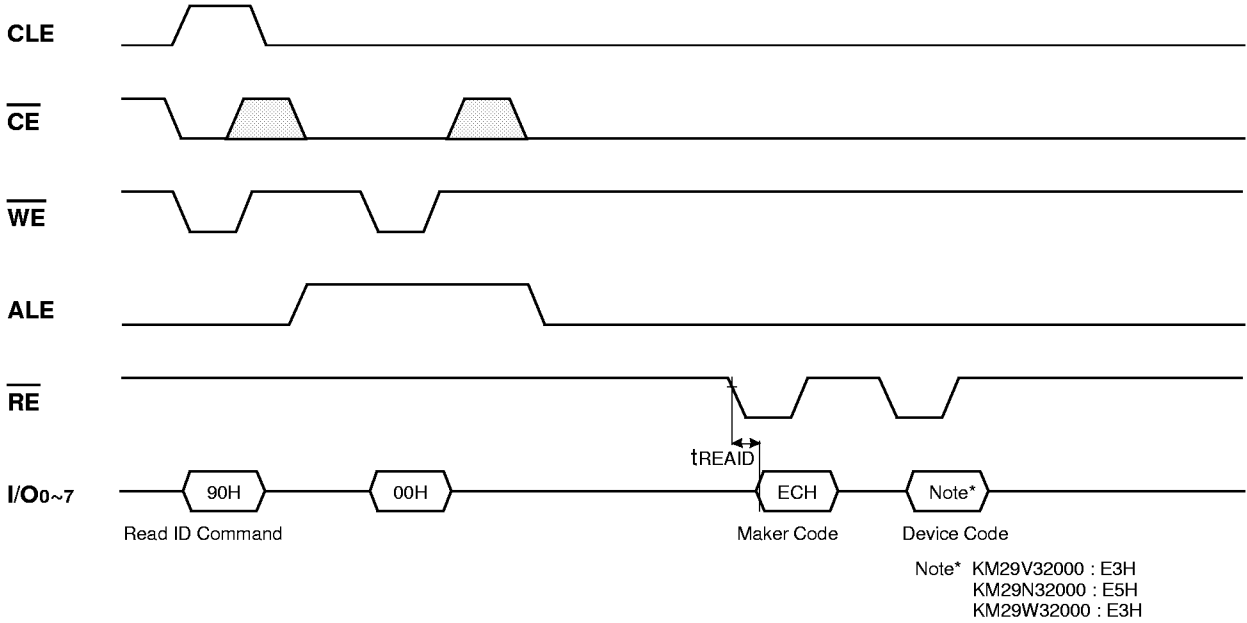

DEVICE OPERATION

PAGE READ

Upon initial device power up, the device defaults to Read1 mode. This operation is also initiated by writing 00H to the command register along with three address cycles. Once the command is latched, it does not need to be written for the following page read operation. Three types of operations are available : random read, serial page read and sequential read.

The random read mode is enabled when the page address is changed. The 528 bytes of data within the selected page are transferred to the data registers in less than 10  $\mu$ s( $t_R$ ). The CPU can detect the completion of this data transfer( $t_R$ ) by analyzing the output of  $\overline{R/B}$  pin. Once the data in a page is loaded into the registers, they may be read out in 50ns cycle time by sequentially pulsing  $\overline{RE}$  with  $\overline{CE}$  staying low. High to low transitions of the  $\overline{RE}$  clock output the data starting from the selected column address up to the last column address(column 511 or 527 depending on state of  $\overline{SE}$  pin).

After the data of last column address is clocked out, the next page is automatically selected for sequential read.

Waiting 10 $\mu$ s again allows for reading of the selected page. The sequential read operation is terminated by bringing  $\overline{CE}$  high. The way the Read1 and Read2 commands work is like a pointer set to either the main area or the spare area. The spare area of bytes 512 to 527 may be selectively accessed by writing the Read2 command with  $\overline{SE}$  pin low. Addresses  $A_0$  to  $A_3$  set the starting address of the spare area while addresses  $A_4$  to  $A_7$  are ignored. Unless the operation is aborted, the page address is automatically incremented for sequential read as in Read1 operation and spare sixteen bytes of each page may be sequentially read. The Read1 command(00H/01H) is needed to move the pointer back to the main area. Figures 3 thru 6 show typical sequence and timings for each read operation.

Figure 3. Read1 Operation

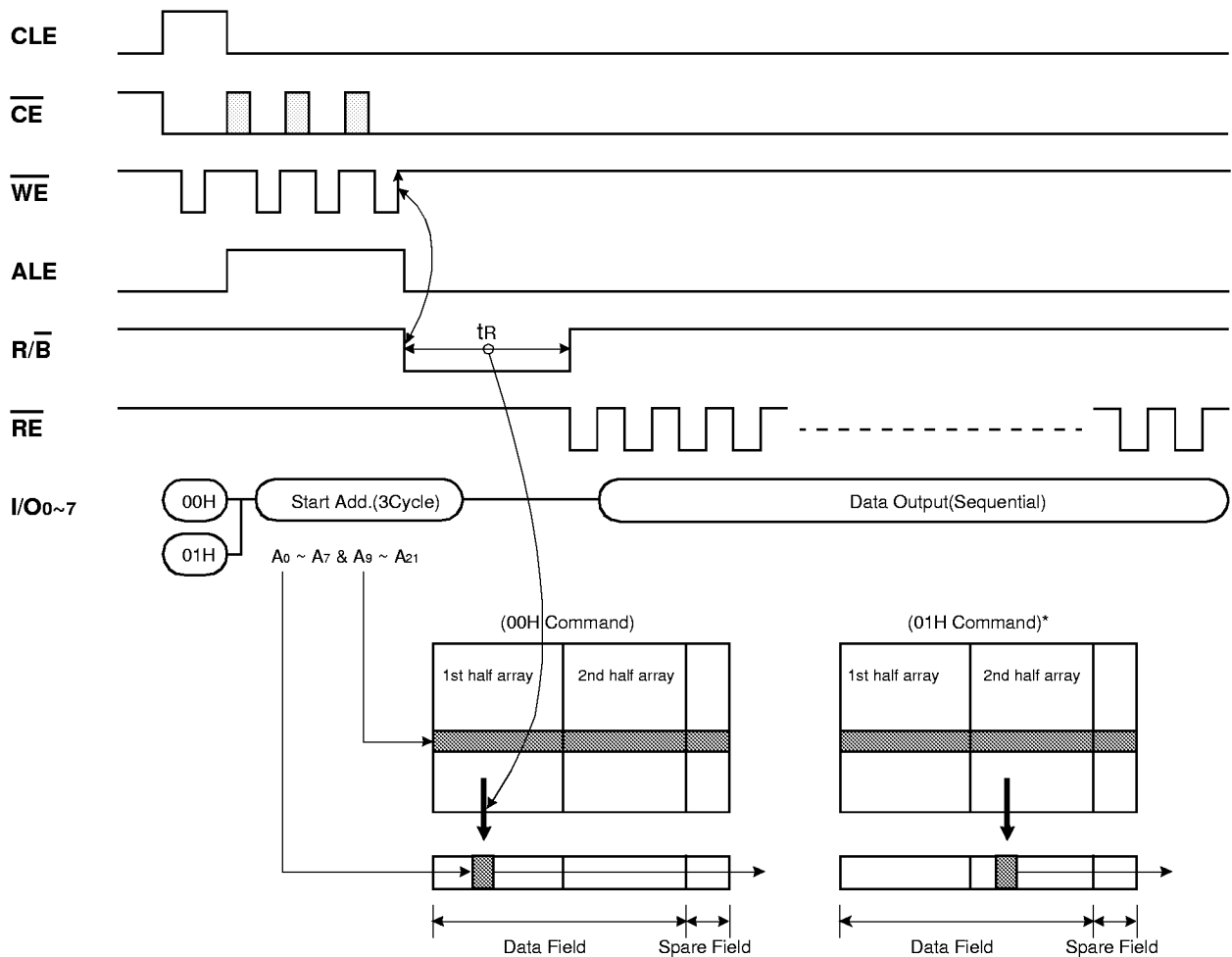

\* After data access on 2nd half array by 01H command, the start pointer is automatically moved to 1st half array (00H) at next cycle.

Figure 4. Read2 Operation

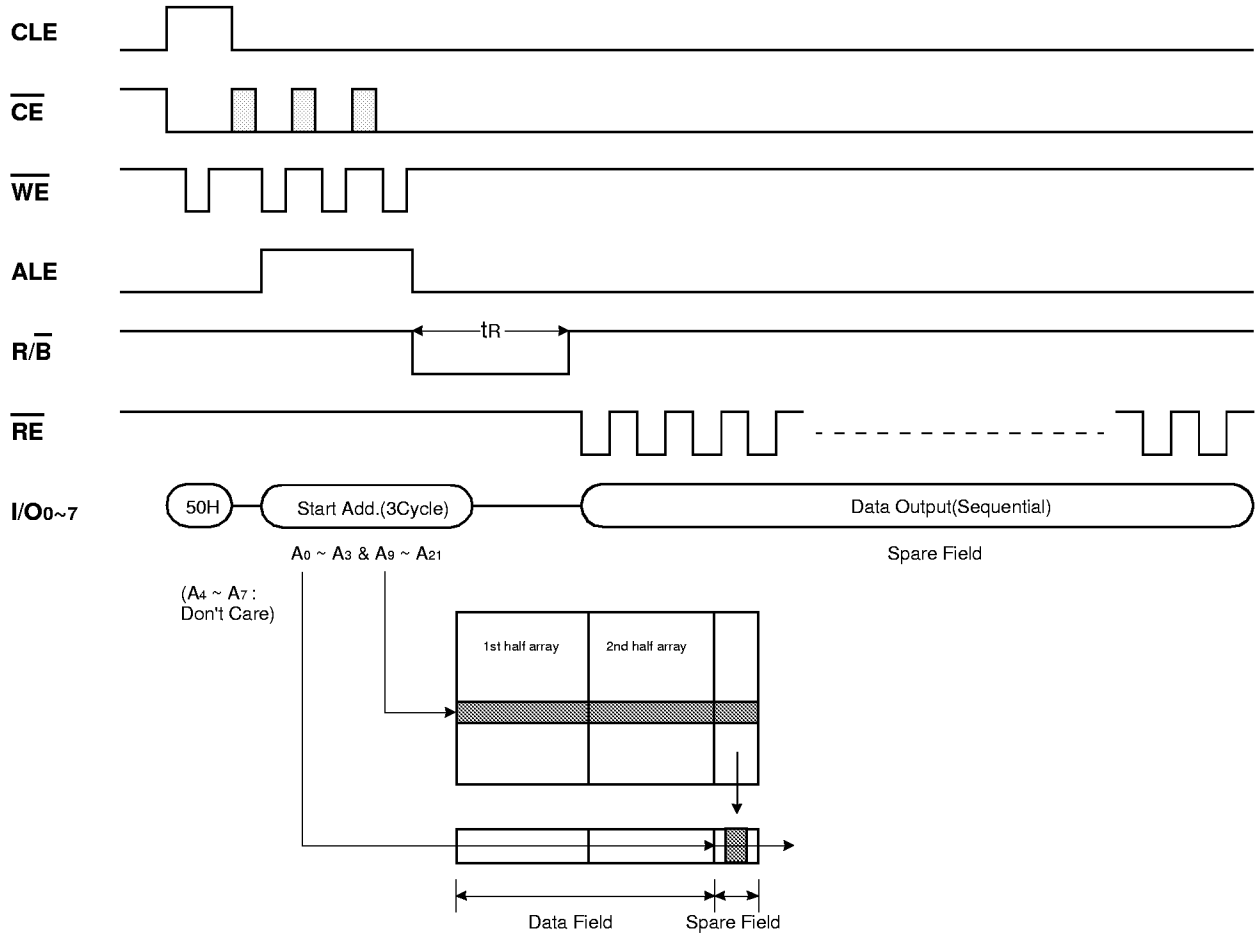

Figure 5. Sequential Row Read1 Operation

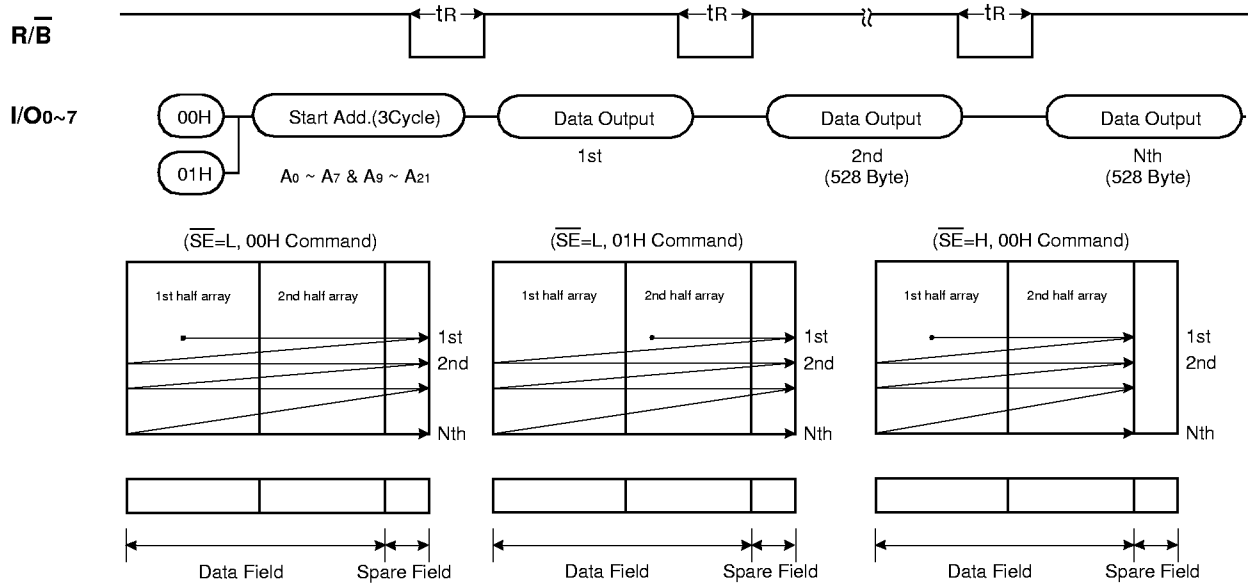
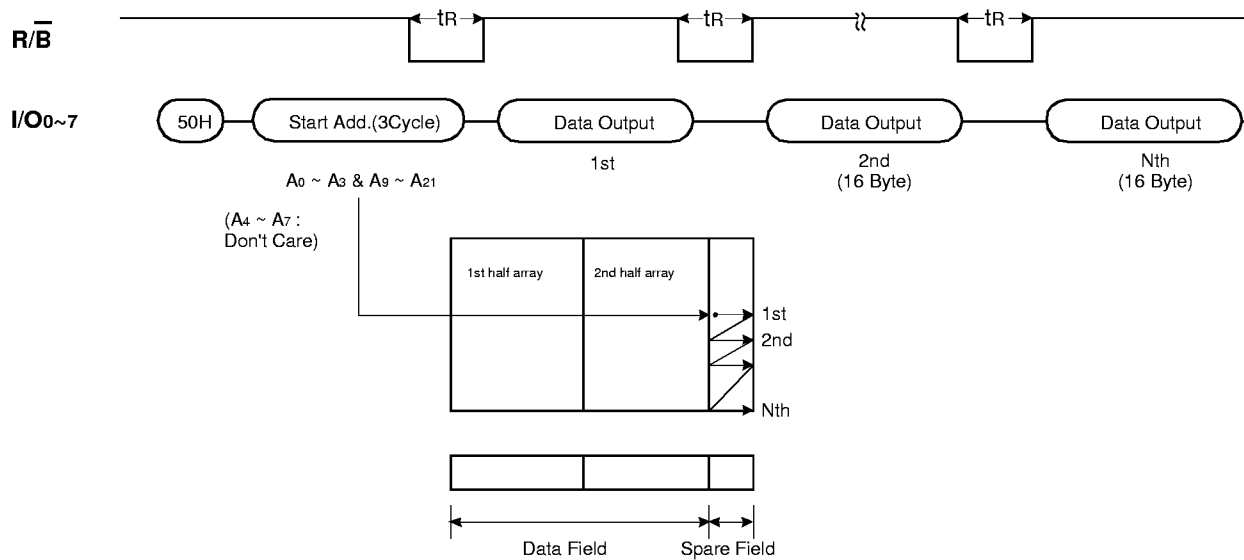

Figure 6. Sequential Read2 Operation ( $\overline{SE}$ =fixed low)



**PAGE PROGRAM**

The device is programmed basically on a page basis, but it does allow multiple partial page programming of a byte or consecutive bytes up to 528, in a single page program cycle. The number of consecutive partial page programming operation within the same page without an intervening erase operation must not exceed ten. The addressing may be done in any random order in a block. A page program cycle consists of a serial data loading period in which up to 528 bytes of data may be loaded into the page register, followed by a nonvolatile programming period where the loaded data is programmed into the appropriate cell. Serial data loading can be started from 2nd half array. About the pointer operation, please refer to the attached technical notes. The serial data loading period begins by inputting the Serial Data Input command(80H), followed by the three cycle address input and then serial data loading. The bytes other than those to be programmed do not need to be loaded.

The Page Program confirm command(10H) initiates the programming process. Writing 10H alone without perviously entering the serial data will not initiate the programming process. The internal write controller automatically executes the algorithms and timings necessary for program and verify, thereby freeing the CPU for other tasks. Once the program process starts, the Read Status Register command may be entered, with  $\overline{RE}$  and  $\overline{CE}$  low, to read the status register. The CPU can detect the completion of a program cycle by monitoring the R/B output, or the Status bit(I/O6) of the Status Register. Only the Read Status command and Reset command are valid while programming is in progress. When the Page Program is complete, the Write Status Bit(I/O0) may be checked(Figure 7). The internal write verify detects only errors for "1"s that are not successfully programmed to "0"s. The command register remains in Read Status command mode until another valid command is written to the command register.

Figure 7. Program & Read Status Operation

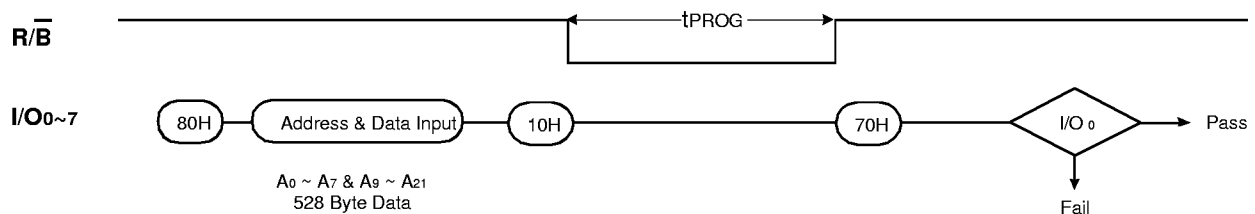

**BLOCK ERASE**

The Erase operation can erase on a block(8K Byte) basis. Block address loading is accomplished in two cycles initiated by an Erase Setup command(60H). Only address A<sub>13</sub> to A<sub>21</sub> is valid while A<sub>9</sub> to A<sub>12</sub> is ignored. The addresses of the block to be erased to FFH. The Erase Confirm command(D0H) following the block address loading initiates the internal erasing process. This two-step sequence of setup followed by execution ensures that memory contents are not accidentally erased due to external noise conditions. At the rising edge of WE after the erase confirm command input, the internal write controller handles erase, erase-verify and pulse repetition where required. If an erase operation error is detected, the internal verify is halted and erase operation is terminated. When the erase operation is completed, the Write Status Bit(I/O<sub>0</sub>) may be checked. Figure 8 details the sequence.

**Figure 8. Block Erase Operation**

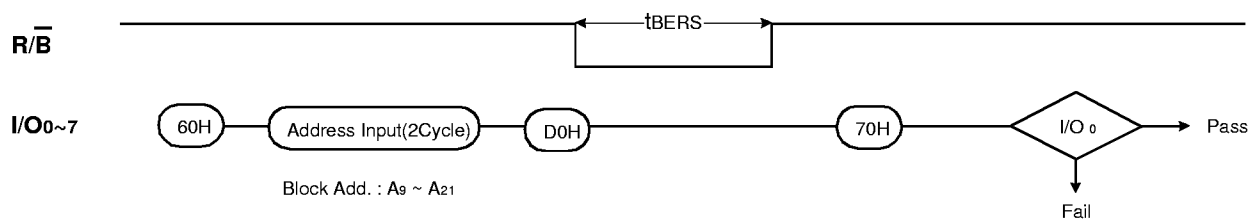

**ERASE SUSPEND/ERASE RESUME**

The Erase Suspend allows interruption during any erase operation in order to read or program data to or from another block of memory. Once an erase process begins, writing the Erase Suspend command (B0H) to the command register suspends the internal erase process, and the  $\overline{R/B}$  signal return to "1". Erase Suspend Status bit will be also set to "1" when the Status Register is read. At this time, blocks other than the suspended block can be read or programmed. The Status Register and  $\overline{R/B}$  operation will function as usual. After the Erase Resume command is written to it, the erase process is restarted from the beginning of the erasing period. The Erase Suspend Status bit and  $\overline{R/B}$  will return to "0". Refer to Figure 9 for operation sequence.

**Figure 9. Erase Suspend & Erase Resume Operation**

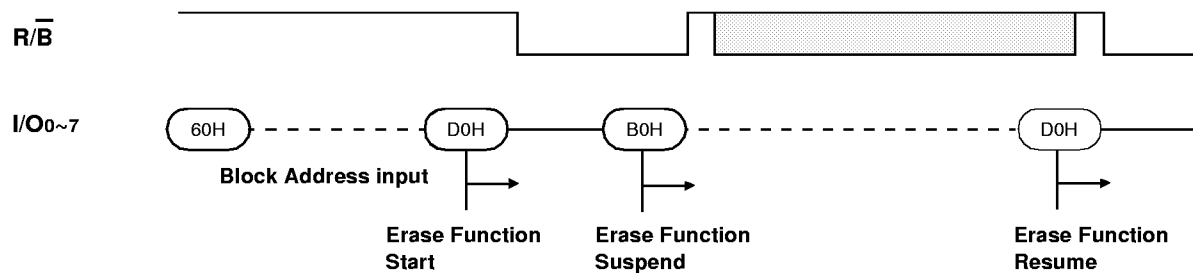

**READ STATUS**

The device contains a Status Register which may be read to find out whether program or erase operation is complete, and whether the program or erase operation completed successfully. After writing 70H command to the command register, a read cycle outputs the contents of the Status Register to the I/O pins on the falling edge of  $\overline{CE}$  or  $\overline{RE}$ , whichever occurs last. This two line control allows the system to poll the progress of each device in multiple memory connections even when R/  $\overline{B}$  pins are common-wired.  $\overline{RE}$  or  $\overline{CE}$  does not need to be toggled for updated status. Refer to table 2 for specific Status Register definitions. The command register remains in Status Read mode until further commands are issued to it. Therefore, if the status register is read during a random read cycle, a read command(00H or 50H) should be given before sequential page read cycle.

**Table2. Status Register Definition**

SR	Status	Definition
I/O <sub>0</sub>	Program / Erase	"0" : Successful Program / Erase "1" : Error in Program / Erase
I/O <sub>1</sub>	Reserved for Future Use	"0"
I/O <sub>2</sub>		"0"
I/O <sub>3</sub>		"0"
I/O <sub>4</sub>		"0"
I/O <sub>5</sub>	Erase Suspend	"0" : Erase in Progress / Completed "1" : Suspended
I/O <sub>6</sub>	Device Operation	"0" : Busy                    "1" : Ready
I/O <sub>7</sub>	Write Protect	"0" : Protected            "1" : Not Protected

**READ ID**

The device contains a product identification mode, initiated by writing 90H to the command register, followed by an address input of 00H. Two read cycles sequentially output the manufacture code(ECH), and the device code (Note\*) respectively. The command register remains in Read ID mode until further commands are issued to it. Figure 9 shows the operation sequence.

**Figure 9. Read ID Operation**

Note\* KM29V32000 : E3H  
KM29N32000 : E5H  
KM29W32000 : E3H

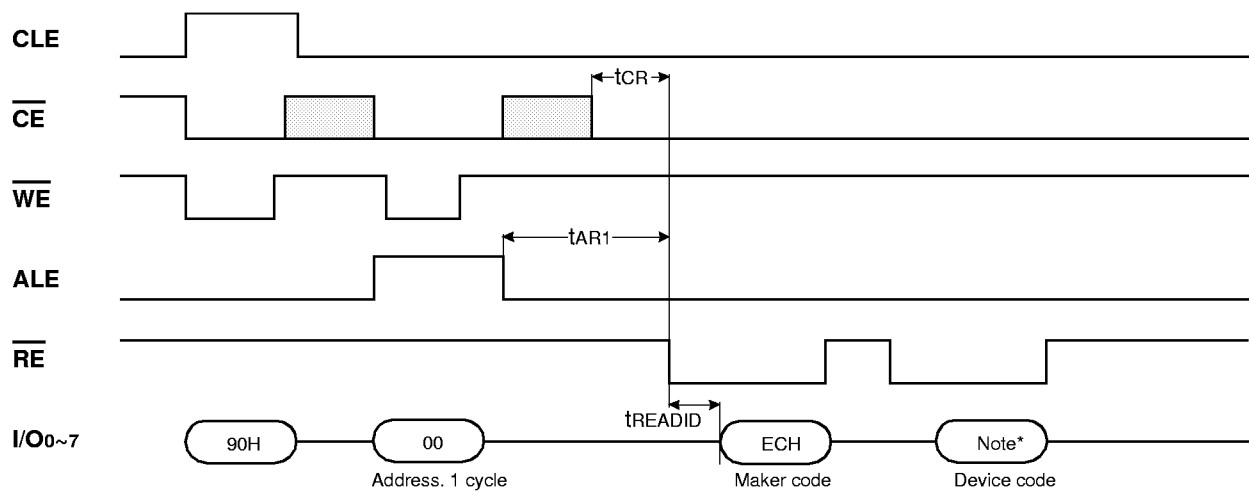

**RESET**

The device offers a reset feature, executed by writing FFH to the command register. When the device is in Busy state during random read, program or erase modes, the reset operation will abort these operation. The contents of memory cells being altered are no longer valid, as the data will be partially programmed or erased. Internal address registers are cleared to "0"s and data registers to "1"s. The command register is cleared to wait for the next command, and the Status Register is cleared to value C0H when  $\overline{WP}$  is high. Refer to table 3 for device status after reset operation. If the device is already in reset state a new reset command will not be accepted by the command register. The  $\overline{R/\overline{B}}$  pin transitions to low for  $t_{RST}$  after the Reset command is written. Reset command is not necessary for normal operation. Refer to Figure 10 below.

Figure 10. RESET Operation

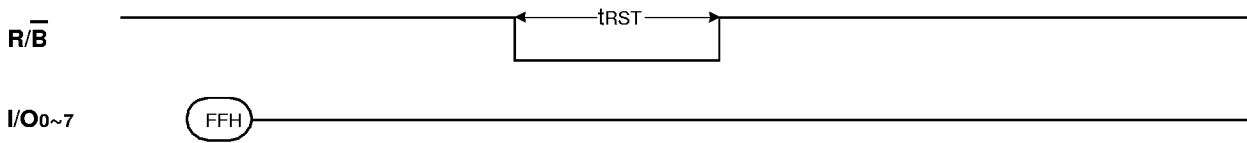

Table3. Device Status

	After Power-up	After Reset
Operation Mode	Read 1	Waiting for next command

**DATA PROTECTION**

The device is designed to offer protection from any involuntary program/erase during power-transitions. An internal voltage detector disables all functions whenever  $V_{cc}$  is below about 2V.  $\overline{WP}$  pin provides hardware protection and is recommended to be kept at  $V_{IL}$  during power-up and power-down as shown in Figure 8. The two step command sequence for program/erase provides additional software protection.

Figure 8. AC Waveforms for Power Transition

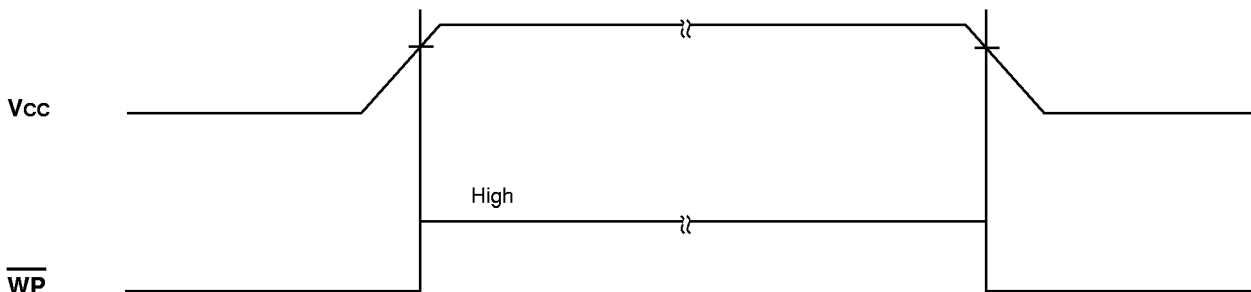



**READY/BUSY**

The device has a  $\overline{R/B}$  output that provides a hardware method of indicating the completion of a page program, erase and random read completion. The  $\overline{R/B}$  pin is normally high but transitions to low after program or erase command is written to the command register or random read is begin after address loading. It returns to high when the internal controller has finished the operation. The pin is an open-drain driver thereby allowing two or more  $\overline{R/B}$  outputs to be Or-tied. An appropriate pull-up resistor is required for proper operation and the value may be calculated by following equation.

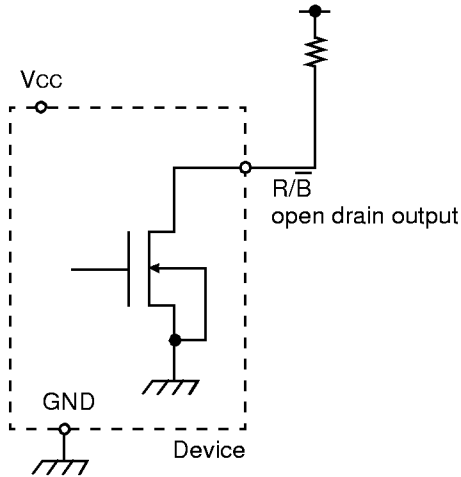

$$R_p = \frac{V_{CC}(\text{Max.}) - V_{OL}(\text{Max.})}{I_{OL} + \sum I_L} = \frac{\text{Note}^*}{8\text{mA} + \sum I_L}$$

where  $I_L$  is the sum of the input currents of all devices tied to the  $\overline{R/B}$  pin.

- Note\* KM29V32000 : 3.2V
- KM29N32000 : 5.1V
- KM29W32000 : 5.1V When  $V_{CC}=3.6\sim 5.5V$
- 3.2V When  $V_{CC}=2.7\sim 3.6V$

# KM29V32000T, KM29V32000IT

# FLASH MEMORY

## PACKAGE DIMENSIONS

44(40) LEAD PLASTIC THIN SMALL OUT-LINE PACKAGE TYPE(II)

