

## FEATURES

- Interpolation up to 1.45 million pulses per second
- Linear, circular, parabolic, logarithmic and exponential interpolations
- Reduces software design necessary for interpolation
- Can be interfaced directly with an 8 bit microprocessor
- Interrupts the microprocessor at the end of the move
- 32 bit data length
- Up to 16 MHz clock frequency
- 28 pin plastic dual in-line package
- Single +5V power supply
- Output for pen up/down control
- On-board general purpose 32 bit counter

## APPLICATIONS

- Motion control systems
- Robotics
- Drawing machines
- Electrical discharge machines
- Special machinery

## INTERPOLATION

The interpolation pulse distribution rate depends on the clock pulse (CP) frequency and the internal calculation time. The internal calculation requires 11 clocks in the case of linear interpolation and 21 clocks in the case of circular or other interpolations.

Interpolation	Interpolation Pulse Distribution Rate
Linear interpolation	1.45 MPPs
Circular or other	725 KPPs

## PURCHASING INFORMATION

Description	Order Code
Interpolation Coprocessor	KM3701BD

## INTERPOLATION COPROCESSOR

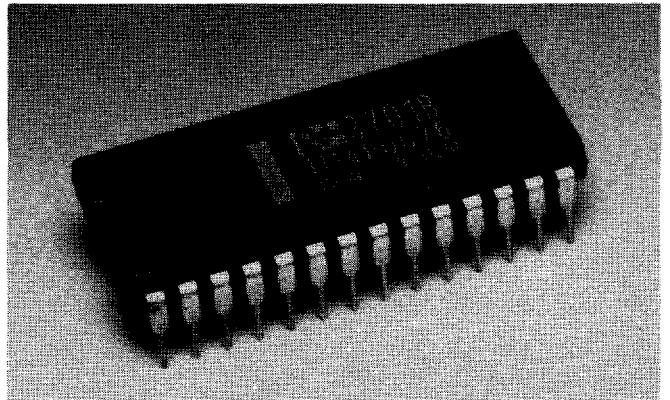

## DESCRIPTION

The KM3701B is a CMOS LSI developed as an interpolation pulse generator for motion control systems. The KM3701B incorporates linear and circular as well as parabolic, logarithmic and exponential interpolations. The functions and coordinate values for linear, circular or other interpolations are set by the microprocessor. Internal calculations are performed with the input of Feed Pulses. Interpolation pulses are then distributed to both the X and Y axes. The frequency of the output pulses from the KM3701B does not depend on the slope of a particular move (when  $\sqrt{2}$  control is enabled). Each KM3701B generates pulses to interpolate 2 axes. When used with the KM3702A (LSI for servo motor control), motion control systems can be built easily, thus reducing development costs and enabling smaller units to be made.

## BLOCK DIAGRAM

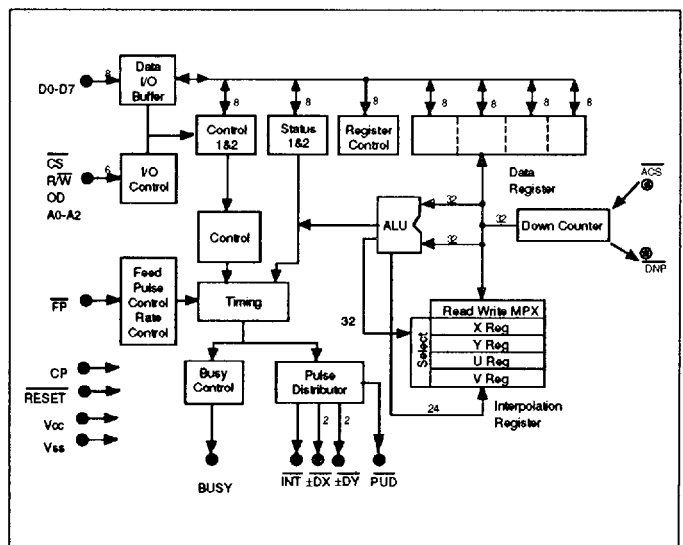

## REGISTER FUNCTIONS

The DATA I/O buffer interfaces with the microprocessor which inputs and outputs 8 bits of data (D0-D7) and is interfaced with 8 internal registers. Each register can be selected according to the address designation (A0-A2). CONTROL WORDS are 8 bit ports for both READ and WRITE and determine the interpolation profile, direction,  $\sqrt{2}$  control, terminal quadrant parameter and function of the 32 bit counter.

STATUS registers are 8-bit ports which represent the internal status of the KM3701B. DATA REGISTER inputs and outputs the coordinate value for interpolation and is interfaced with the interpolation registers. REGISTER CONTROL WORD causes data to be transferred between the data register and one of the internal registers.

## PIN ASSIGNMENT

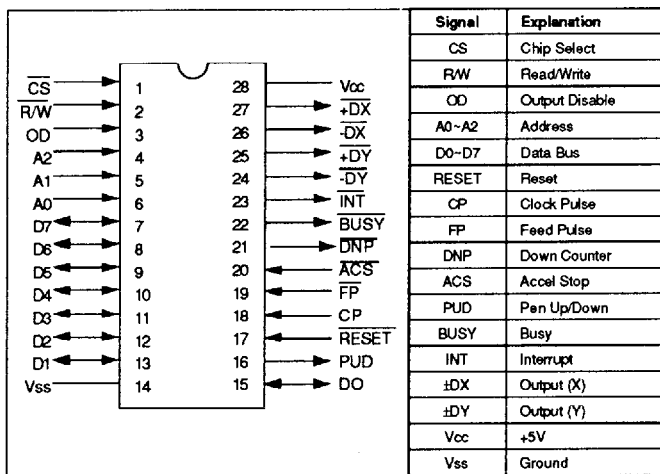

## APPLICATIONS

1. Control of 2 axes can be accomplished by using one KM3701B and two KM3702A's.

2. One KM3701B can control two stepper motors.

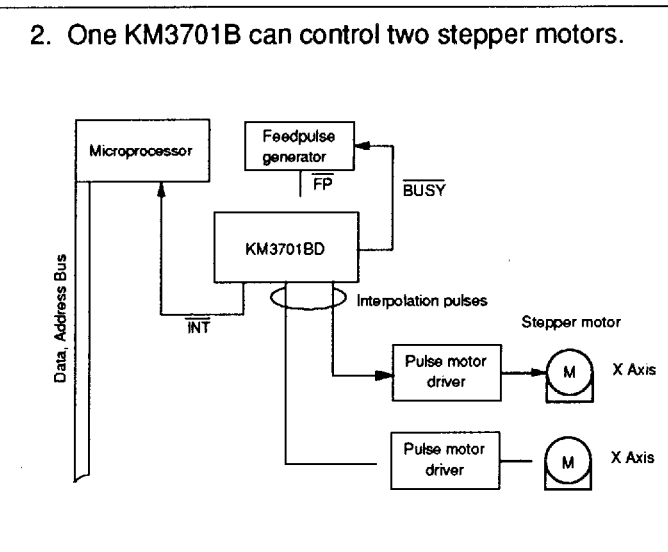
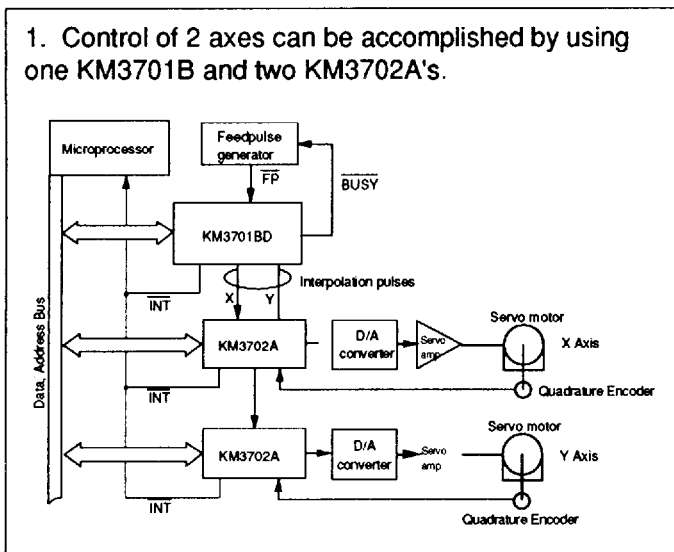

The information furnished by TOKO, Inc. is believed to be accurate and reliable. However, TOKO reserves the right to make changes or improvements in the design, specification or manufacture of its products without further notice. TOKO does not assume any liability arising from the application or use of any product or circuit described herein, nor for any infringements of patents or other rights of third parties which may result from the use of its products. No license is granted by implication or otherwise under any patent or patent rights of TOKO, Inc.



Toko America, Inc.  
1250 Feehanville Drive, Mt. Prospect, IL 60056  
Tel: (708) 297-0070 Fax: (708) 699-7864

### TOKO SALES LOCATIONS

**TOKO America, Inc.**  
1250 Feehanville Drive  
Mount Prospect, IL 60056  
Tel: (708) 297-0070  
Fax: (708) 699-7864

**TOKO America, Inc.**  
2480 North First Street  
Suite 260  
San Jose, CA 95131  
Tel: (408) 432-8281  
Fax: (408) 943-9790

**TOKO America, Inc.**  
107 Mill Plain Road  
Danbury, CT 06811  
Tel: (203) 748-6871  
Fax: (203) 797-1223

**TOKO America, Inc.**  
201 Finney Drive  
Huntsville, AL 35824  
Tel: (205) 772-8004  
Fax: (205) 772-8955