

SEMICONDUCTOR

Numerical Control IC for Rotary Encoder Interface **KM3703D**

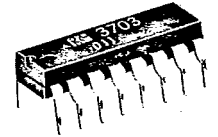

DESCRIPTION

The KM3703D is a rotary encoder interface developed for servo system control.

In operation two-phase pulses from the rotary encoder are decoded to generate pulses for discrimination of the rotating direction of the motor. Output pulses are then synchronized with the basic clock and used as feedback pulses, $\overline{+FB}$, $\overline{-FB}$, to the KM3702.

FEATURES

1. Output pulses can be selected in multiples of X1, X2, and X4.
2. CMOS structure for the input and output and drive is possible at the output.

APPLICATIONS

1. For use in rotary encoder.
2. As a feedback pulse decoder for the Toko KM3702.

MAXIMUM RATINGS

Supply Voltage	V_{DD}	$V_{SS} - 0.3V \sim V_{SS} + 12V$
Power Dissipation	P_D	540mW *
Input voltage	V_{IN}	$V_{SS} - 0.3V \sim V_{DD} + 0.3V$
Output voltage	V_{OUT}	$V_{SS} - 0.3V \sim V_{DD} + 0.3V$
Operating Temperature	T_{OP}	0°C to +70°C
Storage Temperature	T_{stg}	-55°C to +125°C

*Above 25°C, power consumption decreases at rate of 5.4mW/°C

DIMENSIONS

(Unit = mm)

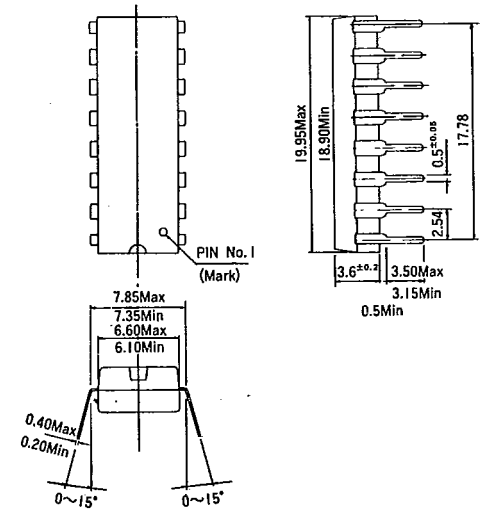

PIN ASSIGNMENT

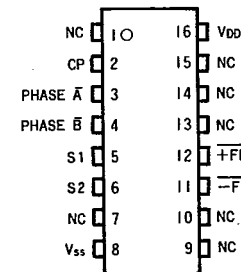

FUNCTIONAL BLOCK DIAGRAM

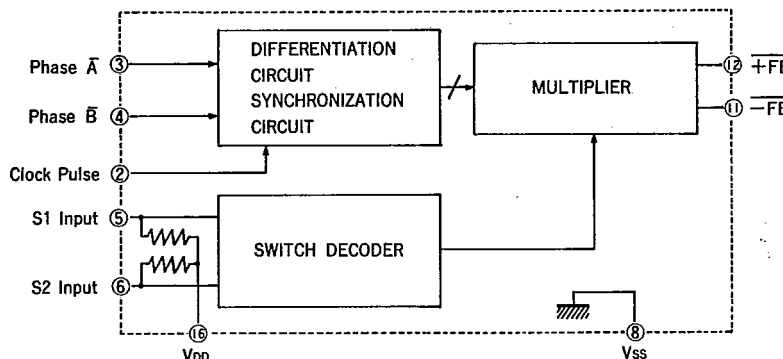

Test Item	Symbol	Ratings			Unit	Test Condition	
		Min.	Std.	Max.			
DC CHARACTERISTICS							
Operating Voltage Range	V _{DD}	4.75	5.0	5.25	V		
Power Supply Current	I _{DD}			4.0	mA	V _{DD} = 5V	
"L" Level Input Voltage	V _{IL}	-0.3		0.6	V	I _{IL} = -10μA	
"H" Level Input Voltage	V _{IH}	3.5		5.25	V	I _{IH} = 10μA	
"L" Level Output Voltage	V _{OL}			0.4	V	I _{OL} = 400μA	
"H" Level Output Voltage	V _{OH}	2.4			V	I _{OH} = -200μA	
S1 & S2 Terminal	Shorted to Vcc Current	I _{PU}	-50	-200	-500	μA	
	Open Circuit Voltage	V _{PU}	4.0			V	
AC CHARACTERISTICS							
Clock Pulse Period	T _{cyc}	0.65	1	10	μS	Frequency = 1MHz	
Clock Pulse Width	T _{cw}	150		$\frac{T_{cyc}}{2}$	nS		
Clock Pulse Rise Time	T _{cr}			30	nS		
Clock Pulse Fall Time	T _{cf}			30	nS		
Duty for Input	T _{dy}		50		%		
Pulse Width for Input	T _{iw}	2 T _{cyc}			nS		
Output Delay Time	T _d			300	nS	C _L = 60pF	

Notes : V_{IL} : CP, phase \bar{A} , phase \bar{B} , S1, S2.

V_{IH} : CP, phase \bar{A} , phase \bar{B} .

V_{OL}, V_{OH} : +FB, -FB.

I_{PU}, V_{PU} : S1, S2.

CLOCK PULSE : CP.

Input : phase \bar{A} , phase \bar{B} .

Output : +FB, -FB.

WAVEFORMS

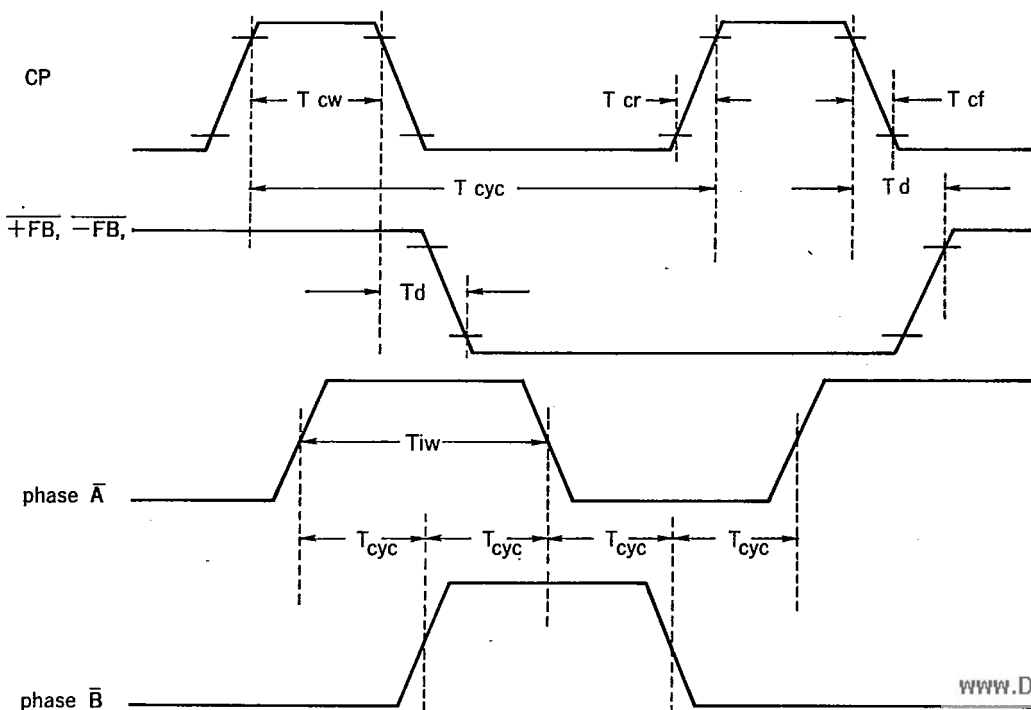

TIMING CHART

T-52-13-25

www.DataSheet4U.com

■ CLOCKWISE (Positive)

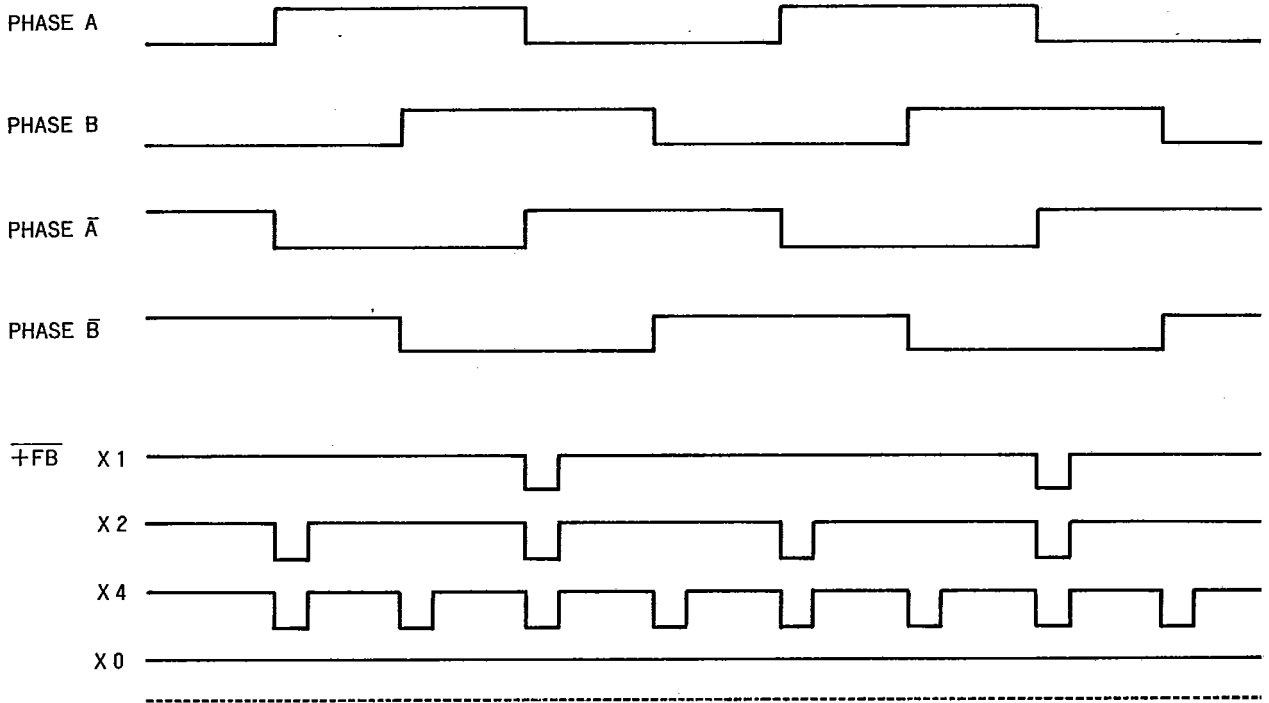

■ COUNTERCLOCKWISE (Negative)

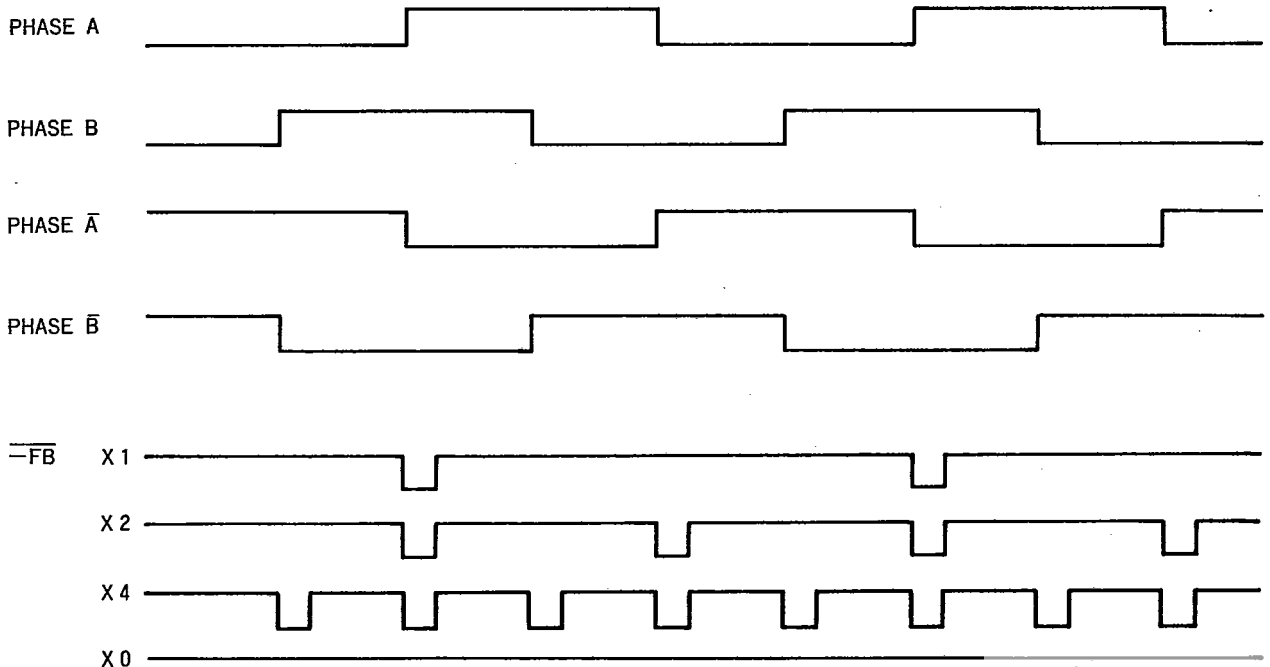

T-52-13-25

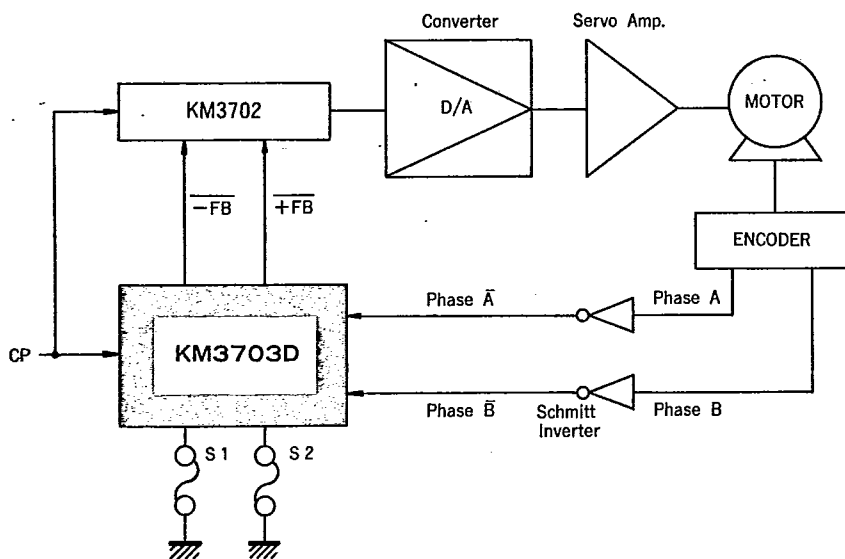

S 1	S 2	MULTIPLIER
OPEN	OPEN	× 1
Vss	OPEN	× 2
OPEN	Vss	× 4
Vss	Vss	× 0

DESCRIPTION OF FUNCTIONS

The two outputs, A and B with 90 degree phase shift from the external encoder are waveshaped with an external Schmitt inverter.

The lead or lag of Phase A or B is detected to determine the rotating direction of the motor.

Then one clock width of the feedback pulse, +FB or -FB, is generated in the positive or negative direction synchronized with the fall of the clock pulse.

With combination of switches S1 and S2, the multiplication function, X1, X2, and X4, is available.

S1 and S2 are "pulled up" to VDD with internal resistors; depending on the mode in use, connections are open or closed (refer to table).

PRECAUTIONS IN USE

1. Due to CMOS structure, when voltage other than 5V is used, there will be a change in characteristics of input and output levels.
2. Maximum input frequency to phase A and B is approximately 250kHz.

*Specifications given herein are subject to change without notice. Please confirm when ordering.

YOUR DISTRIBUTOR



TOKO, INC.

HEAD OFFICE : 1-17, 2-clgime, Higashi-Yukigaya, Ohta-ku, Tokyo, 145 Japan

Tel : Tokyo 727-1161 Telex : RCL TOKO J22696 Cable : "RADIO COILA B" TOKYO

● TOKO, INC. HONG KONG BRANCH Tel : 3-428131~6 Telex : 802-39126(39126 TOKOM HX)

● TOKO, INC. SINGAPORE BRANCH Tel : 2554000 Telex : 87-21444(SP TOKO RS 21444)