

General Description

This Trench MOSFET has better characteristics, such as fast switching time, low on resistance, low gate charge and excellent avalanche characteristics. It is mainly suitable for Back-light Inverter and Power Supply.

FEATURES

- $V_{DSS}=40V$, $I_D=54A$.
- Low Drain-Source ON Resistance.
 - : $R_{DS(ON)}=8.5m\ \Omega$ (Max.) @ $V_{GS}=10V$
 - : $R_{DS(ON)}=11m\ \Omega$ (Max.) @ $V_{GS}=4.5V$
- Super High Dense Cell Design.
- High Power and Current Handling Capability.

MAXIMUM RATING (Ta=25 °C Unless otherwise Noted)

| CHARACTERISTIC | | SYMBOL | N-Ch | UNIT |
|---|--------------------------------|------------|----------|--------------|
| Drain-Source Voltage | | V_{DSS} | 40 | V |
| Gate-Source Voltage | | V_{GSS} | ± 20 | V |
| Drain Current | DC@ $T_C=25\ ^\circ C$ (Note1) | I_D | 54 | A |
| | Pulsed (Note2) | I_{DP} | 100 | |
| Drain-Source-Diode Forward Current | | I_S | 100 | A |
| Drain Power Dissipation | @ $T_C=25\ ^\circ C$ (Note1) | P_D | 45 | W |
| | @ $T_a=25\ ^\circ C$ (Note2) | | 3.1 | |
| Maximum Junction Temperature | | T_j | 150 | $^\circ C$ |
| Storage Temperature Range | | T_{stg} | -55~150 | $^\circ C$ |
| Thermal Resistance, Junction to Case (Note1) | | R_{thJC} | 2.8 | $^\circ C/W$ |
| Thermal Resistance, Junction to Ambient (Note2) | | R_{thJA} | 40 | $^\circ C/W$ |

Note 1) R_{thJC} means that the infinite heat sink is mounted.

Note 2) Surface Mounted on 1" × 1" Pad of 2 oz copper.

PIN CONNECTION (TOP VIEW)

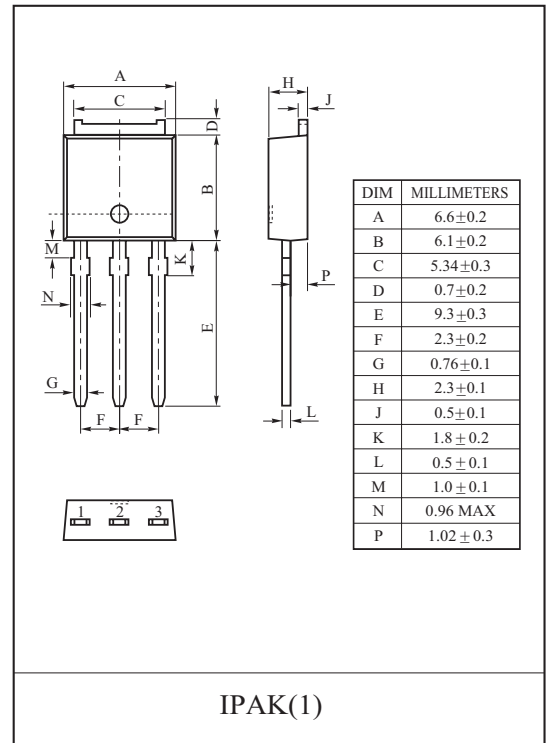
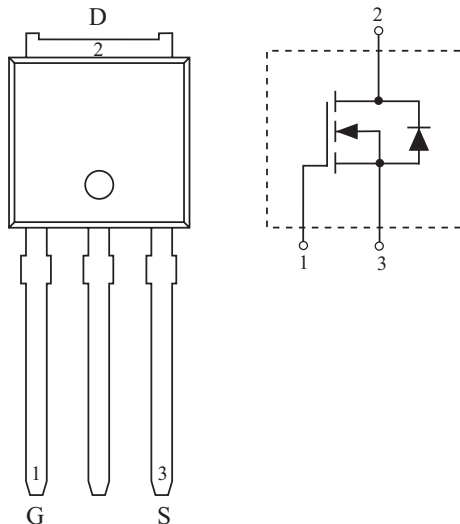

Marking

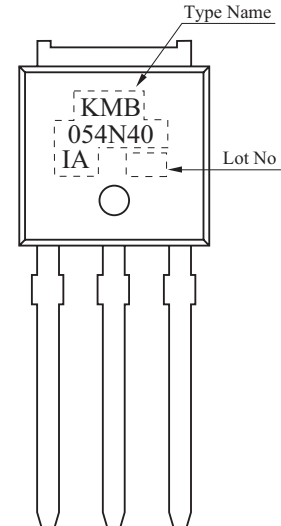

KMB054N40IA

ELECTRICAL CHARACTERISTICS (Ta=25 °C)

| CHARACTERISTIC | SYMBOL | TEST CONDITION | MIN. | TYP. | MAX. | UNIT | | |
|--|----------------|--|---|------|-----------|------------|---|----|
| Static | | | | | | | | |
| Drain-Source Breakdown Voltage | BV_{DSS} | $V_{GS}=0V, I_D=250\mu A$ | 40 | - | - | V | | |
| Drain Cut-off Current | I_{DSS} | $V_{GS}=0V, V_{DS}=32V$ | - | - | 1 | μA | | |
| Gate Leakage Current | I_{GSS} | $V_{GS}=\pm 20V, V_{DS}=0V$ | - | - | ± 100 | nA | | |
| Gate Threshold Voltage | V_{th} | $V_{DS}=V_{GS}, I_D=250\mu A$ | 1 | 1.9 | 3 | V | | |
| Drain-Source ON Resistance | $R_{DS(ON)*}$ | $V_{GS}=10V, I_D=14A$ | - | 6.5 | 8.5 | m Ω | | |
| | | $V_{GS}=4.5V, I_D=11A$ | - | 8.5 | 11 | | | |
| | | $V_{GS}=10V, I_D=14A, T_j=125^\circ C$ | - | 10.4 | 14 | | | |
| Forward Transconductance | g_{fs*} | $V_{DS}=10V, I_D=20A$ | - | 58 | - | S | | |
| Dynamic | | | | | | | | |
| Input Capacitance | C_{iss} | $V_{DS}=20V, f=1MHz, V_{GS}=0V$ | - | 1280 | - | pF | | |
| Output Capacitance | C_{oss} | | - | 250 | - | | | |
| Reverse Transfer Capacitance | C_{rss} | | - | 125 | - | | | |
| Total Gate Charge | $V_{GS}=10V$ | $V_{DS}=20V, V_{GS}=10V, I_D=14A$ | - | 25.4 | - | nC | | |
| | $V_{GS}=5V$ | | - | 13.8 | - | | | |
| Gate-Source Charge | Q_{gs}^* | | - | 5.7 | - | | | |
| Gate-Drain Charge | Q_{gd}^* | | - | 5.4 | - | | | |
| Turn-On Delay Time | $t_{d(on)}^*$ | | $V_{DD}=20V, V_{GS}=10V$ $I_D=1A, R_G=6\Omega$ | - | 19 | | - | ns |
| Turn-On Rise Time | t_r^* | | | - | 16 | | - | |
| Turn-Off Delay Time | $t_{d(off)}^*$ | - | | 60 | - | | | |
| Turn-Off Fall Time | t_f^* | - | | 14 | - | | | |
| Source-Drain Diode Ratings | | | | | | | | |
| Source-Drain Forward Voltage | V_{SDF}^* | $V_{GS}=0V, I_S=14A$ | - | 0.8 | 1.2 | V | | |
| Note>* Pulse Test : Pulse width <300 μs , Duty cycle < 2% | | | | | | | | |

KMB054N40IA

Fig1. $I_D - V_{DS}$

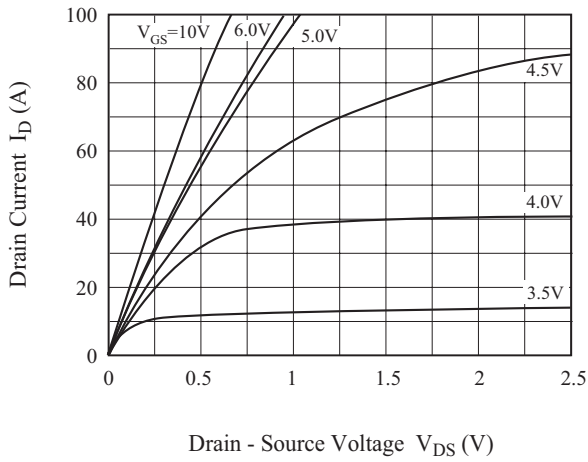

Fig2. $R_{DS(ON)} - I_D$

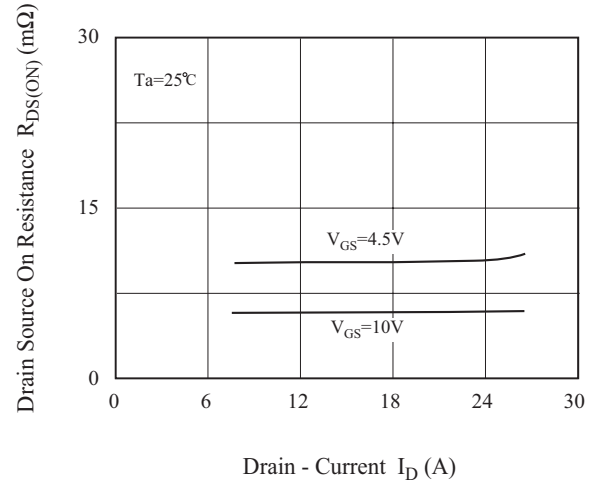

Fig3. $I_D - V_{GS}$

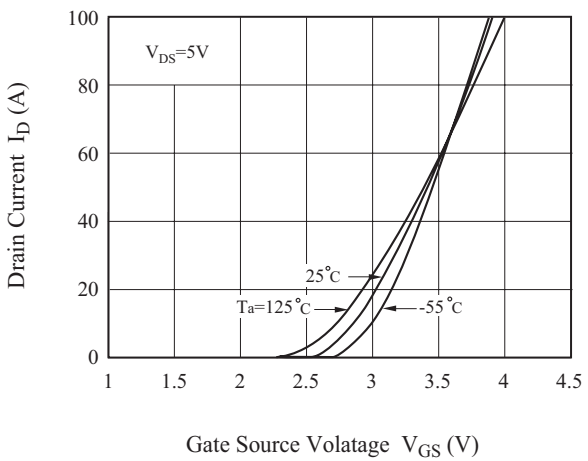

Fig4. $R_{DS(on)} - T_j$

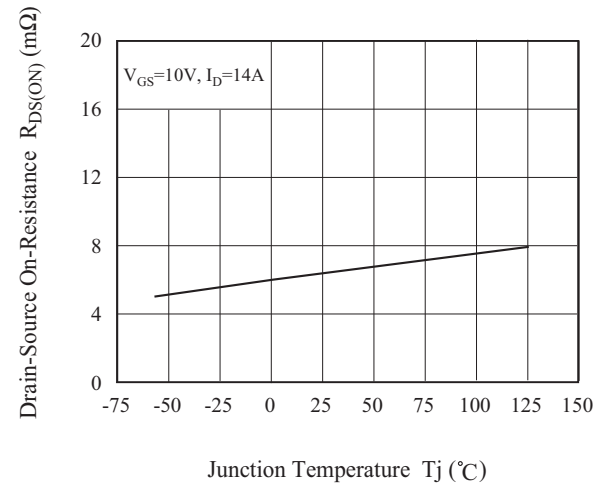

Fig5. $V_{th} - T_j$

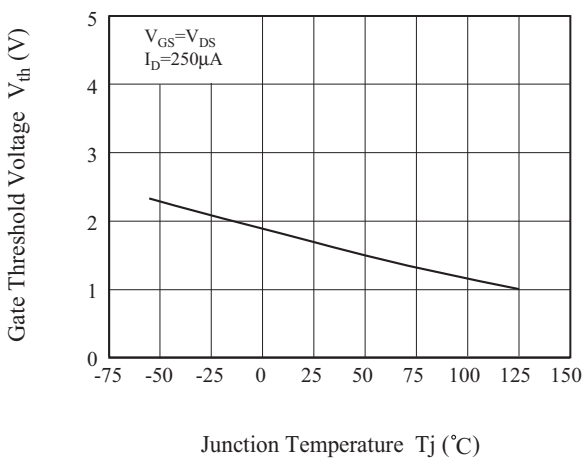
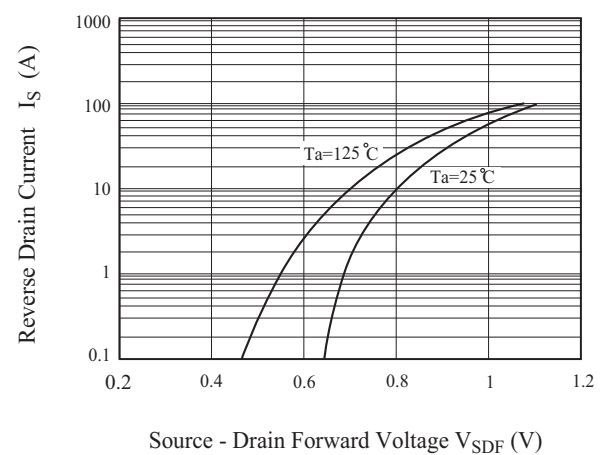

Fig6. $I_S - V_{SDF}$



KMB054N40IA

Fig 7. $V_{GS} - Q_g$

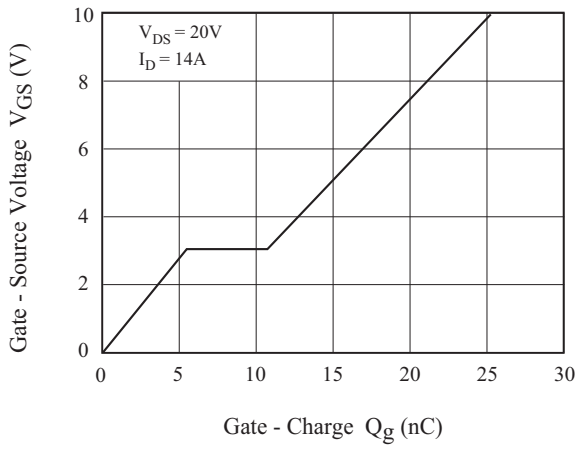

Fig 8. $C - V_{DS}$

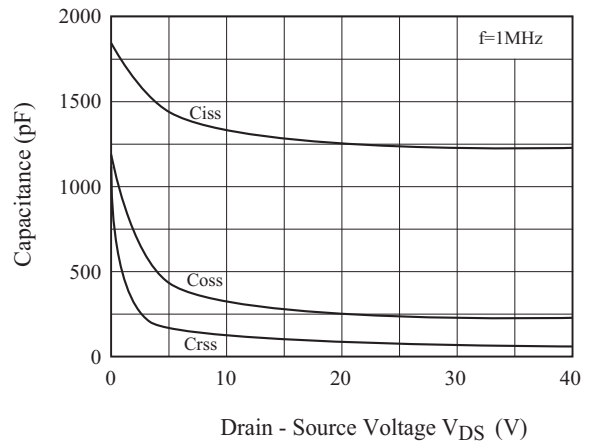

Fig9. Safe Operation Area

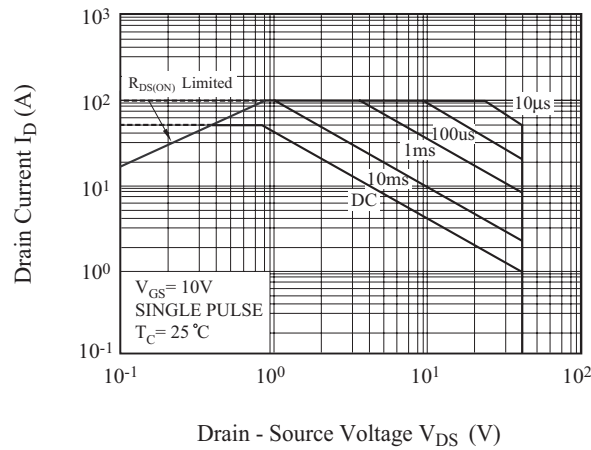

Fig10. Transient Thermal Response Curve

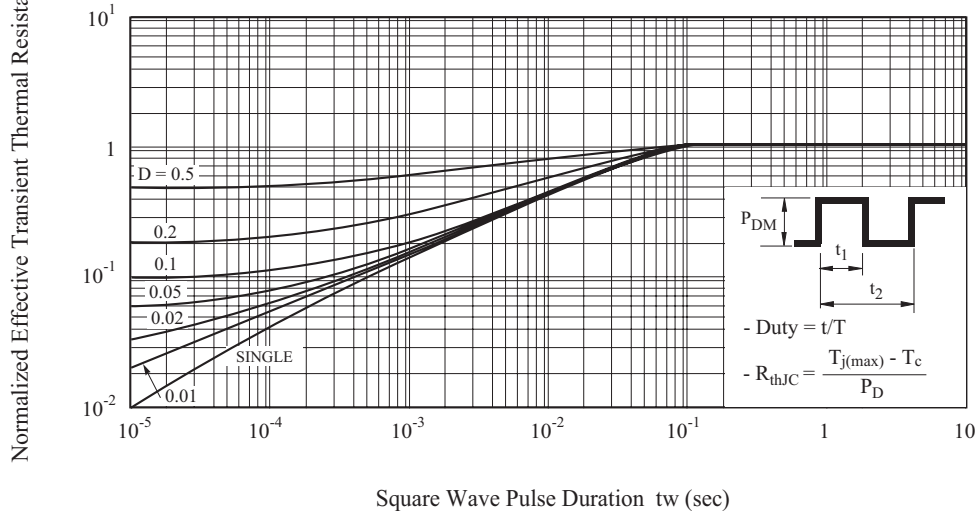

Fig11. Gate Charge Circuit and Wave Form

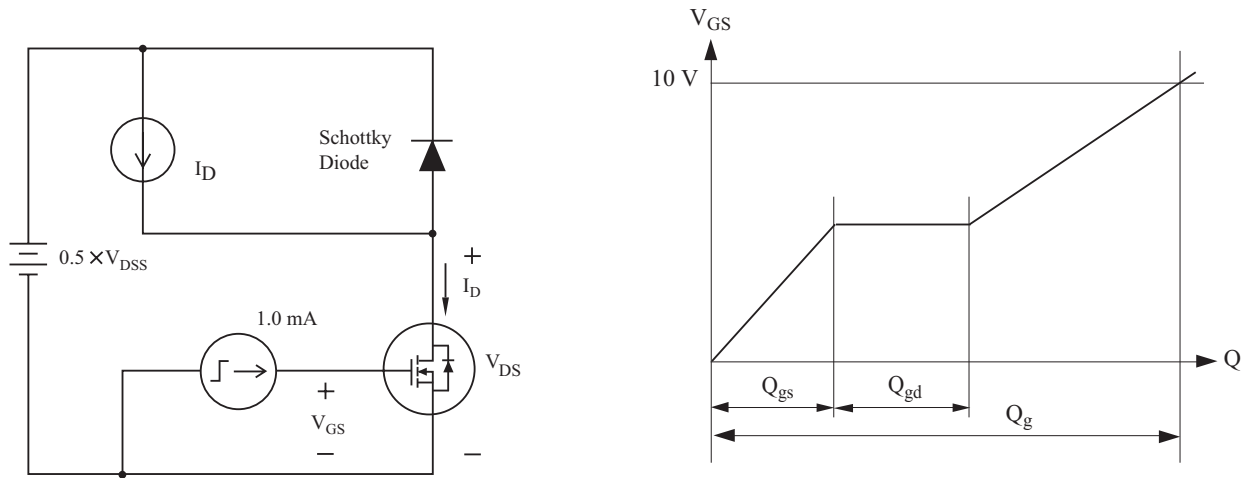

Fig12. Resistive Load Switching

