

KME-M001C

The KME-M001C UV Sensor combines a High Power UV LED with LTV Sensor, Band pass filter.

FEATURES

- Difficult for dust and debris to come onto element
- Easy equipping
- Detection of the Existence for a Fluorescent Material

APPLICATIONS

- ATM
- Vending Machine
- etc

DIMENSION

(Unit : mm)

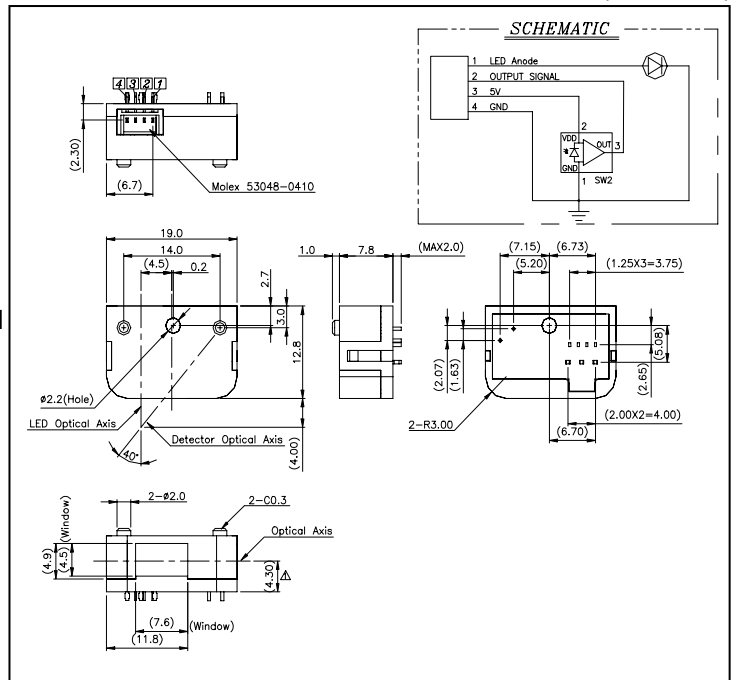

MAXIMUM RATINGS

(Ta=25°C)

Parameter	Symbol	Rating	Unit	
Input	Power Dissipation	P_D	60	mW
	Forward Current	I_F	25	mA
	Peak Forward Current ⁽¹⁾	I_{FP}	80	mA
	Reverse Current	I_R	60	mA
Output	Supply Voltage	V_{DD}	6	V
	Output Current	I_O	10	mA
Operating Temperature		T_{opr}	-20 ~ 75	°C
Storage Temperature Range		T_{stg}	-25 ~ 85	°C
ESD Withstand Voltage (Human Body Model)		V_{ESD}	±2.0	kV

Note 1. Pulse width ≤ 500usec ; Duty factor : 1%

ELECTRO-OPTICAL CHARACTERISTICS

(Ta=25°C)

Parameter	Symbol	Conditions	Min.	Typ.	Max.	Unit
Input	Forward Voltage	$I_F=20mA$	-	3.5	4.0	V
	Peak Wavelength	$I_F=20mA$	-	375	-	nm
Output	Supply Voltage	-	4.5	5.0	5.5	V
	Dark Voltage	$E_e=0$	0	-	15	mV
	Maximum Output Voltage	$V_{DD}=4.5V$	-	4.49	-	V
Transmission	Forward Current	$L=4mm, V_{DD}=5V,$ $V_{TAR}^{(2)}=4.5V,$ Fluorescent Paper	2	-	20	mA
	Low Level Output Voltage	$L=4mm, V_{DD}=5V,$ $I_{TAR}^{(3)},$ Non- Fluorescent Paper	-	-	1	V
Response Time	Rise Time		-	160	-	μs
	Fall Time		-	150	-	μs

Note 2. V_{TAR} = Target Voltage = 4.5V

Note 3. I_{TAR} = I_F (Forward Current) when V_{TAR}

Note 4. Fluorescent Paper = HP Bright white inkjet paper (C5977B)

KME-M001C

Forward current Vs. Forward voltage

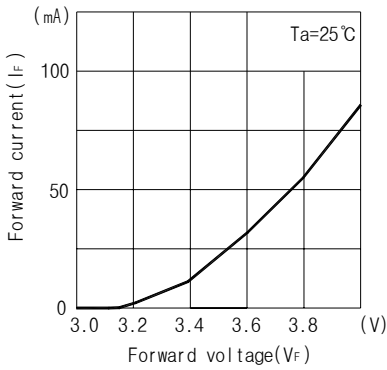

Duty Ratio Vs. Allowable Forward Current

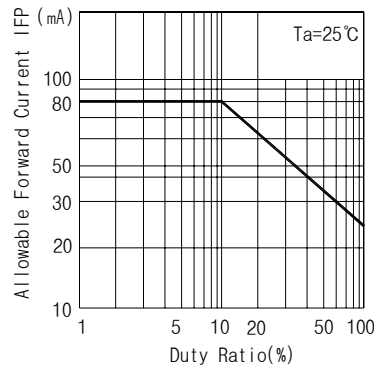

Relative Collector Current Vs. Ambient temperature

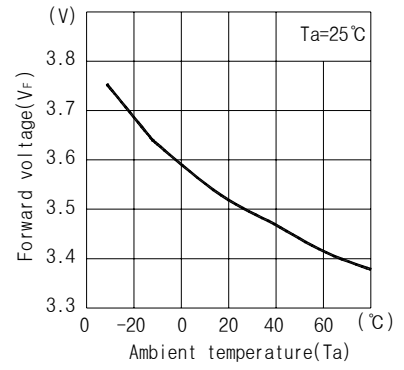

Output Voltage Vs. Forward Current

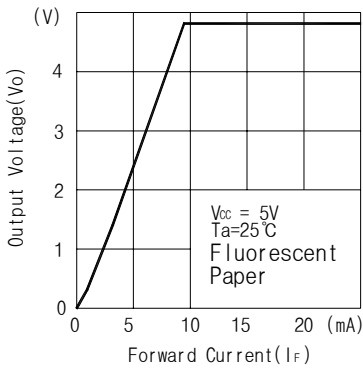

Ambient temperature

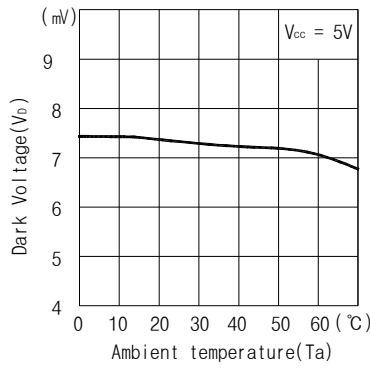

Relative Output Voltage Vs. Moving distance

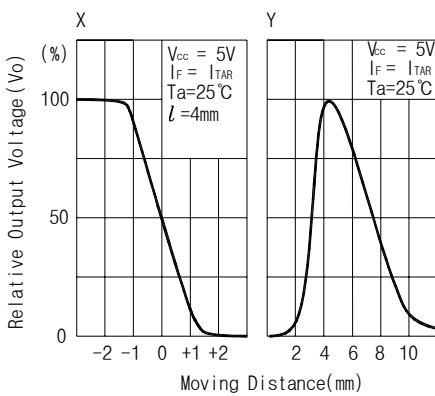

Method of measuring position detection characteristic

