

Features

1. Compact dual-in-line package.
2. 600V peak blocking voltage.
3. Isolation voltage between input and output (Viso:5000Vrms).

For 115/240 Vac (rms) Application:

1. Solenoid/Valve Controls.
2. Lighting Controls.
3. Static Power Switches.
4. AC Motor Drives.
5. Temperature Controls.
6. E. M. Contactors.
7. AC Motor Staters.
8. Solid State Relays.
9. Programmable controllers.

Outside Dimension:Unit (mm)

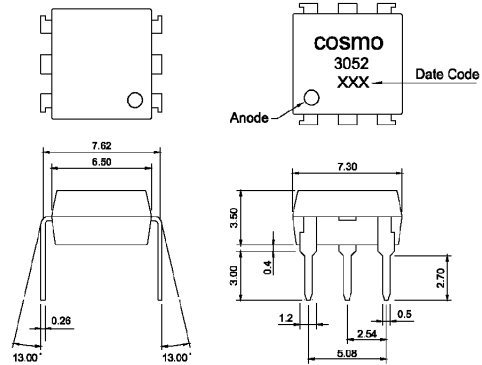

Schematic:Top View

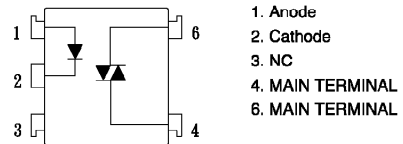

Absolute Maximum Ratings

(Ta=25°C)

Parameter	Symbol	Rating	Unit
Input	Forward current	IF	50 mA
	Peak forward current (100us)	IFM	1 A
	Reverse voltage	VR	6 V
	Power dissipation	PD	70 mW
Output	Off-State Output Terminal voltage	VDRM	600 Vpeak
	On-State R. M. S. Current	IT(RMS)	100 mA
	Peak Repetitive Surget Current (PW=10ms, DC 10%)	ITSM	1 A
	Power dissipation	PD	300 mW
Total power dissipation	Ptot	330 mW	
Isolation voltage 1 minute	Viso	5000 Vrms	
Operating temperature	Topr	-40 to +85 °C	
Storage temperature	Tstg	-50 to +125 °C	
Soldering temperature 10 second	Tsol	260 °C	

Electro-optical Characteristics

(Ta=25°C)

Parameter	Symbol	Conditions	MIN.	TYP.	MAX.	Unit
Input	Forward voltage	IF=10mA	—	1.2	1.4	V
	Peak forward voltage	IFM=0.5A	—	—	3.5	V
	Reverse Leakage Current	VR=4V	—	—	10	µA
Output	Peak Blocking Current	VDRM=600V	—	—	100	nA
	ON-State Voltage	ITM=100mA	—	1.6	2.8	V
Transfer characteristics	Holding Current		—	1.0	—	mA
	Critical rate of rise of OFF-state voltage	VDRM= (1/√2) *Rated	600	1000	—	V/µS
	Isolation resistance	DC500V	5x10 ¹⁰	10 ¹¹	—	ohm
	Minimum trigger current	Main Terminal Voltage=3V	—	—	10	mA
	Turn-on time	Vd=6V, RL=100 ohm, IF=20mA	—	—	100	µS

