

For 115/240 Vac (rms) Application:

1. Solenoid/Valve Controls
2. Lighting Controls
3. Static Power Switches
4. Ac Motor Drives
5. Temperature Controls
6. E.M. Contactors
7. Ac Motor Starters
8. Solid State Relays
9. Available package : DIP/ SMD/ H.

Outside Dimension : Unit (mm)

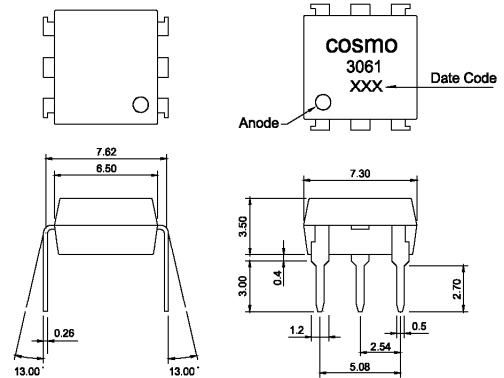

Schematic : Top View

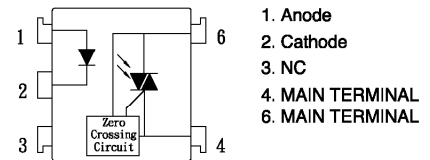

Absolute Maximum Ratings

(Ta=25°C)

Parameter	Symbol	Rating	Unit
Input	Forward current	IF	50 mA
	Peak forward current	IFM	1 A
	Reverse voltage	VR	6 V
	Power dissipation	PD	70 mW
Output	Off-State Output Terminal voltage	VDRM	600 Vpeak
	Peak Repetitive Surget Current	ITSM	1 A
	Power dissipation	Pd	300 mW
Total power dissipation		Ptot	330 mW
Isolation voltage 1 minute		Viso	5000 Vrms
Operating temperature		Topr	-40 to +80 °C
Storage temperature		Tstg	-40 to +125 °C
Soldering temperature 10 seconds		Tsol	260 °C

Electro-optical Characteristics

(Ta=25°C)

Parameter	Symbol	Conditions	MIN.	TYP.	MAX.	Unit
Input	Forward voltage	IF = 10mA	—	1.2	1.4	V
	Reverse Leakage Current	VR = 4V	—	—	10	UA
Output	Peak Blocking Current	VDRM = Rated	—	60	500	nA
	ON-State Voltage	ITM = 100mA	—	1.8	3	V
	Critical rate of rise of OFF-state voltage	VDRM = (1/√2) * Rated	600	—	—	V/μS
Transfer characteristics	Holding Current		—	100	—	uA
	Inhibit Voltage (MT1-MT2 Voltage above which device not trigger.)	IF = 15mA	—	5	20	V
	Leakage in Inhibited State	IF = Rated IFT, Rated VDRM, Off State	—	—	500	uA
	Isolation resistance	DC500V	5x10 ¹⁰	10 ¹¹	—	ohm
	Minimum trigger current	Main Terminal Voltage=3V	—	—	15	mA

