

EM-CCD Color Camera

KP-DE500

Specifications

(Revision 1.0)

7810009 1/

DWN		• •		Hitachi Kokusai Electric Inc. Tokyo Japan	7810009 1/
DSGN		• •			
CHKD		• •			
APPD		• •			

1. General

The KP-DE500 is ultra high sensitivity color camera that installed the electron multiplication type CCD (EM-CCD) image sensor.

2. Principal features

1) Ultra high sensitivity

It has materialized ultra high sensitivity because it is doing multiply charge directly in the charge domain before conversion to voltage.

Image is not fuzzy like a picture picked up a moving objects and walking person at very dark condition.

2) High color fidelity

By RGB primary color mosaic filters, the picture of high vertical resolution and high color fidelity can be acquired.

3) New digital signal processor (DSP)

The clear picture of a high signal to noise ratio (S/N) is obtained by the new digital signal processor (DSP) adoption which has improved luminance signal processing, such as 5H enhancer processing.

4) Electronic shutter

The electronic shutter can be set in 7 steps from standard 1/60 second to 1/2000 second. Auto electronic shutter (AES) operates to 1/2000 second. Even with a fixed iris lens, the shutter speed responds to the amount of light to keep the signal output at optimum level.

5) White balance

a) Auto-tracking white balance [ATW] (detecting white color in the scene at a color temperature form 2,500K to 8,000K)

b) Preset white balance [AWC]

c) Manual white balance. (R, B gain control)

A

B

C

D

E

F

7810009 2/

DWN	/	.	.
DSGN	/	.	.
CHKD	/	.	.
APPD	/	.	.

Hitachi Kokusai Electric Inc.
Tokyo Japan

7810009 2/

6) Color- Monochrome (B/W MODE)

Clear color video in the daytime, very high sensitivity of monochrome video at night by the automatic change function. This function is suitable for the day / night continuous surveillance.

7) Picture quality menus

A wide variety of modes and parameters can be selected from menus and adjusted by using rear panel key buttons.

8) Others.....

- a) Video signal polarity (Selectable negative/positive)
- b) Text display
- c) Remote control (Via RS-232C)

A

B

C

D

E

F

7810009 3/

DWN	/	.	.
DSGN	/	.	.
CHKD	/	.	.
APPD	/	.	.

Hitachi Kokusai Electric Inc.
Tokyo Japan

7810009 3/

3. Specifications

- 1) Imaging device : 1/2-inch progressive scan frame interline CCD
(with on-chip microlenses)
- Total number of pixels : 680(H) x 500(V)
No. of effective pixels : 658(H) x 489(V)
Scanning area : 6.58(H) x 4.89(V) mm
Unit cell size : 10.0(H) x 10.0(V) μ m (Square pixel)
Color filter : R, G, B primary color mosaic filters on chip
- 2) Scanning system : 2:1 interlace scan (NTSC mode)
- 3) Frequency Horizontal : 15.734 kHz
Vertical : 59.94 Hz
- 4) Sync system : Internal
- 5) Video signal output : Composite video : 1.0 Vp-p/75 unbalanced
Video : 0.7 Vp-p positive or negative
(negative picture)
Sync : 0.3 Vp-p negative
Burst : 0.3 Vp-p more than 8 cycles
Subcarrier frequency : 3.579545 MHz \pm 75Hz
Connector : BNC type
- 6) Video signal processing : Digital processing (input 10 bits)
- 7) S/N (Y signal) : More than 50dB (AGC, enhancer and gamma off)
- 8) Resolution (Y signal at center)
Horizontal : 480 TV lines
Vertical : 350 TV lines
- 9) Minimum illumination : 0.009 lx (Color, F1.4, AGC ON, SENS UP OFF, 50IRE)
0.0005 lx
(Monochrome, F1.4, AGC ON, SENS UP OFF, 50IRE)
- 10) Sensitivity selection : AGC OFF / ON (Factory setting is ON)
Manual Gain Adjustable at AGC OFF
Limit Gain Adjustable at AGC ON
- 11) Electric shutter speed : Selectable in 7 steps & AES (Factory setting is 1/60)
1/60, 1/100, 1/125, 1/250, 1/500, 1/1000, 1/2000
AES : From 1/60 second to 1/2000 second
- 12) Integration multiple [SENS UP] setting : Automatic or Manual (fixed) (Factory setting is OFF)
Automatic : 2, 4, 6, 8, 10, 12, 16, 32, 64 times
Manual : 2, 4, 6, 8, 10, 12, 16, 32, 64, 88, 128 times

Note: When the SENS UP scale factor increased, white spot and fixed pattern noise increase and picture quality may fall off.

DWN		.	.		Hitachi Kokusai Electric Inc. Tokyo Japan	7810009 4/
DSGN		.	.			
CHKD		.	.			
APPD		.	.			

- 13) Light control mode (The auto level control system of AES, lens iris[DC], AGC and SESN UP.)
 : AVERAGE / PEAK&AVERAGE / BLC
 (Factory setting is AVERAGE)
 BLC : Scanning area is selectable from 9 area.
- 14) Auto-iris lens outputs : DC / VIDEO (Factory setting is DC)
 Iris control voltage input (galvanometer) type lens [DC]
 Coupling coil impedance
 Damper : 1,150 ± 10%, Drive : 190 ± 10%
 Video signal input type lens [VIDEO]
 Luminance signal : 1.0 Vp-p/high impedance
 Power supply : 12 VDC 60 mA
- 15) White balance : Selectable in 3 modes (Factory setting is ATW)
 Auto-tracking[ATW] / preset[AWC] /
 R/B gain manual control[MANUAL]
- 16) B/W mode : Selectable in 3 modes (Factory setting is OFF)
 OFF : Color mode
 ON : Monochrome mode
 AUTO : Mode selected in response to brightness.
 Can be set for high, medium or low.
- 17) DNR (Noise reduction) : Selectable in 3 modes (Factory setting is AUTO(HI))
 OFF / AUTO / ON
- 18) Text display : 24 alpha-numeric characters in one line
- 19) Picture adjustment : Modes and settings can be selected and adjusted from
 on-screen menu
- 20) Remote control : Modes and settings can be selected and adjusted from PC.
 RS-232C level, Connector: 12pin
- 21) Power supply : 12 VDC ± 10 %
- 22) Power consumption : Approx. 1.5A (Omitting 60mA for auto-iris lens)
- 23) Lens mount : C/CS mount (Flange-back adjustment)
- 24) Ambient temperature
 Operating : -10 to +50 , 30 to 80 %RH
 Storage : -20 to +60 , 20 to 90 %RH
 Note : If operated continuously, be sure to use at less than +40 (104F)
 for long term stable performance.
- 25) Vibration endurance : 24.5 m/s² (10 to 200Hz, 30 minutes each on XYZ axes)
 Note : Do not subject to strong vibration for long periods of time.

A

B

C

D

E

F

7810009 5/

DWN	/	.	.	Hitachi Kokusai Electric Inc. Tokyo Japan	7810009 5/
DSGN	/	.	.		
CHKD	/	.	.		
APPD	/	.	.		

1

2

3

4

- 26) External dimensions : 78(W) x 63(H) x 170(D)
(not including lens and protrusions)
- 27) Mass : Approx. 610g (without lens)
- 28) Supplied equipment : Camera 1
Operating instructions 1
DC input plug (R03-P3F) 1

A

B

C

D

E

F

7810009 6/

DWN	/	.	.
DSGN		.	.
CHKD		.	.
APPD		.	.

Hitachi Kokusai Electric Inc.
Tokyo Japan

7810009 6/

1

2

3

29) External view

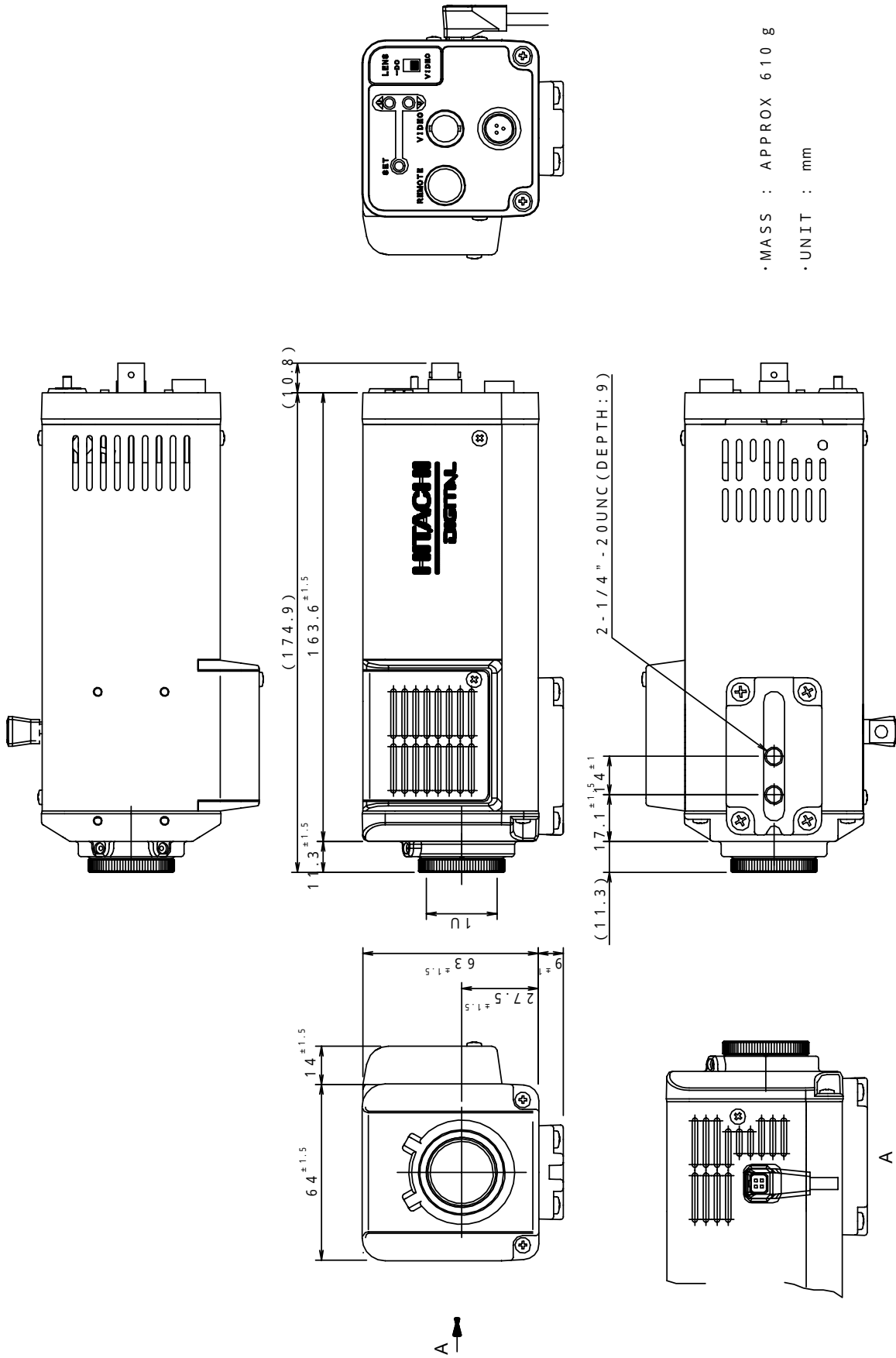

7/ 7810009

DWN	/	.	.
DSGN	/	.	.
CHKD	/	.	.
APPD	/	.	.

Hitachi Kokusai Electric Inc.
Tokyo Japan

7/ 7810009

1 3 4

A B C D E F

1 2 3

Notice:

These specifications are subject to change without prior notice due to product improvement. Confirm the most recent specifications at time of order.

Hitachi Kokusai Electric certifies this product complies with the standard warranty conditions of Hitachi Kokusai Electric, and that quality control is implemented to the extent required to comply with these conditions.

Operating notice

The camera pays attention be sufficient that the followings handling notice of the camera handling will be maintained good picture quality.

1) The camera should not use in dusty place and/or where closes a fan, because it is cooling CCD with a peltier-element and fan.

2) When camera operating temperature goes up, the white spots of CCD and dark current increase and picture quality decrease noticeably.

In case of the camera is installed into camera housing, the inside temperature of the housing should be keep below 40 and maintained with cooling FAN to prevent rise in temperature.

3) In case of the camera with housing continuously operates the long time, recommend the FAN of the camera housing is exchanged regularly every 3 years. If the FAN does not work properly, a white spot and fixed pattern noise increase then picture quality comes down.

Warranty and service:

1) The guarantee period is one year after the data purchase. However, the defects due to erroneous use or intentional act are excluded.

2) As the defect after expiration of the guarantee period, where product repair is possible, repair will be performed at charge.

3) The present Warranty pertains only to the camera unit. Secondary malfunctions attributable to camera failure as well as expenses incurred by disassembly and reassembly of the related system, are beyond the scope of this Warranty.

4) Compensation for loss of business, loss or damage to software, database and other contingent losses are beyond the scope of this Warranty.

5) Hitachi Kokusai Electric Inc. is not liable for the losses caused when the equipment is used in a system, use for business trades, production process, medical fields, crime prevention applications, etc.

6) The parts used in the equipment have their respective lives. The lives of such parts will be shortened under the environments of high temperature or high humidity. When the stable operation is required for a long time, it is recommended to perform periodical maintenance and inspection every year or every two years.

7810009 8/

DWN	/	.	.	Hitachi Kokusai Electric Inc. Tokyo Japan	7810009 8/
DSGN	/	.	.		
CHKD	/	.	.		
APPD	/	.	.		

A

B

C

D

E

F

