

# KP2670A/2800V

\*\*\*\*\*

## HIGH POWER THYRISTOR FOR PHASE CONTROL APPLICATIONS

### Features:

- . All Diffused Structure
- . Spoke Amplifying Gate Configuration
- . Blocking capability up to 2800 volts
- . High dV/dt Capability
- . Pressure Assembled Device

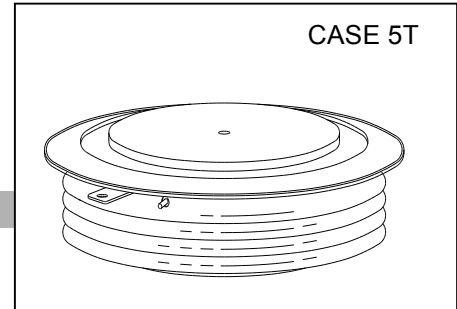

## ELECTRICAL CHARACTERISTICS AND RATINGS

### Blocking - Off State

Device Type	V <sub>RRM</sub> (1)	V <sub>DRM</sub> (1)	V <sub>RSM</sub> (1)
KP2670A	2800	2800	2900

- V<sub>RRM</sub> = Repetitive peak reverse voltage  
 V<sub>DRM</sub> = Repetitive peak off state voltage  
 V<sub>RSM</sub> = Non repetitive peak reverse voltage (2)

Repetitive peak reverse leakage and off state leakage	I <sub>RRM</sub> /I <sub>DRM</sub>	10 mA 200 mA (3)
Critical rate of voltage rise	dV/dt (4)	1000 V/μsec

### Notes:

- All ratings are specified for T<sub>j</sub>=25 °C unless otherwise stated.
- (1) All voltage ratings are specified for an applied 50Hz/60Hz sinusoidal waveform over the temperature range -40 to +125 °C.
  - (2) 10 msec. max. pulse width
  - (3) Maximum value for T<sub>j</sub> = 125 °C.
  - (4) Minimum value for linear and exponential waveshape to 70% rated V<sub>DRM</sub>. Gate open. T<sub>j</sub> = 125 °C.
  - (5) Non-repetitive value.

### Conducting - on state

Parameter	Symbol	Min.	Max.	Typ.	Units	Conditions
Average value of on-state current	I <sub>T(AV)</sub>		2670		A	Sinewave, 180° conduction, T <sub>c</sub> =70°C
RMS value of on-state current	I <sub>TRMS</sub>		4270		A	Nominal value
Peak one cycle surge (non repetitive) current	I <sub>TSM</sub>		42000		A	8.3 msec (60Hz), sinusoidal waveshape, 180° conduction, T <sub>j</sub> = 125 °C 10.0 msec (50Hz), sinusoidal waveshape, 180° conduction, T <sub>j</sub> = 125 °C
			38200		A	
I square t	I <sup>2</sup> t		5.1x10 <sup>6</sup>		A <sup>2</sup> s	8.3 msec and 10.0 msec
Latching current	I <sub>L</sub>		1500		mA	V <sub>D</sub> = 24 V; R <sub>L</sub> = 12 ohms
Holding current	I <sub>H</sub>		250		mA	V <sub>D</sub> = 24 V; I = 2.5 A
Peak on-state voltage	V <sub>TM</sub>		1.55		V	I <sub>TM</sub> = 4000 A
Critical rate of rise of on-state current (5)	di/dt		300		A/μs	Switching from V <sub>DRM</sub> ≤ 800 V, non-repetitive
Critical rate of rise of on-state current	di/dt		100		A/μs	Switching from V <sub>DRM</sub> ≤ 800 V

# KP2670A/2800V

## Gating

Parameter	Symbol	Min.	Max.	Typ.	Units	Conditions
Peak gate power dissipation	$P_{GM}$		200		W	$t_p = 40 \mu s$
Average gate power dissipation	$P_{G(AV)}$		5		W	
Peak gate current	$I_{GM}$		20		A	
Gate current	$I_{GT}$		300		mA	
Gate voltage	$V_{GT}$	0.30	3.5		V	

## Dynamic

Parameter	Symbol	Min.	Max.	Typ.	Units	Conditions
Delay time	$t_d$				$\mu s$	
Turn-off time (with $V_R = -50 V$ )	$t_q$				$\mu s$	

## THERMAL AND MECHANICAL CHARACTERISTICS AND RATINGS

Parameter	Symbol	Min.	Max.	Typ.	Units	Conditions
Operating temperature	$T_j$	-40	+125		$^{\circ}C$	
Storage temperature	$T_{stg}$	-40	+150		$^{\circ}C$	
Thermal resistance - junction to case	$R_{\theta(j-c)}$		0.012		$^{\circ}C/W$	Double sided cooled Single sided cooled
Thermal resistance - case to sink	$R_{\theta(c-s)}$		0.002		$^{\circ}C/W$	Double sided cooled * Single sided cooled *
Mounting force	P	8000	10000		lb. kN	
Weight	W				Lb. Kg.	

\* Mounting surfaces smooth, flat and greased

Note : for case outline and dimensions, see case outline drawing

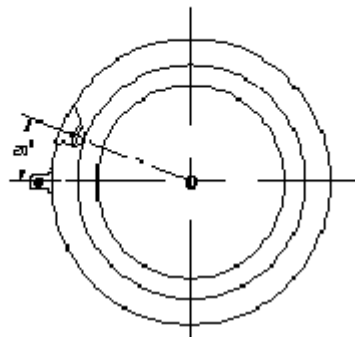

A: 73 MM  
B: 109 MM  
C: 99 MM  
E: 26 MM

