

Feature

- Hermetic ceramics-metal stud structure
- Capacity of supporting high surge current

Typical Application

- DC motor control, Control DC power supply
- AC switch and thermal control, Synchronous motor excitation

$I_{T(AV)}$	500A
V_{DRM}/V_{RRM}	100-3000V
I_{TSM}	2836A
I^2t	163 KA ² s

Voltage Ratings

Type number	Voltage Code	V_{DRM}/V_{RRM} max. repetitive peak and off-state voltage (1) V	V_{RSM} non-repetitive voltage (2) V	maximum peak	I_{DRM}/I_{RRM} @ $T_J=T_J$ mA
KP500A	10	100	150		30
	20	200	300		
	40	400	500		
	60	600	700		
	80	800	900		
	100	1000	1100		
	120	1200	1300		
	140	1400	1500		
	160	1600	1700		

On-state Conduction

Symbol	Characteristic	KP500A	Units	Conditions		
$I_{T(AV)}$	Max. average on-state current @ Case temperature	500	A	180°C sinusoidal conduction		
$I_{T(RMS)}$	Max. RMS on-state current	360	A			
I_{TSM}	Max. peak, one-cycle non-repetitive surge current	5700	A	t=10ms	No voltage reapplied	Sinusoidal half wave Initial $T_J=T_J$ Max
		5970		t=8.3ms		
		4800		t=10ms	100% V_{RRM} reapplied	
		5000		t=8.3ms		
I^2t	Maximum I^2t for fusing	148	KA ² s	t=10ms	No voltage	
		163		t=8.3ms		
		105		t=10ms	100% V_{RRM} reapplied	
		115		t=8.3ms		
$V_{T(TO)1}$	Low level value of threshold voltage	0.90	V	$(16.7\% \times I_{T(AV)} < I < \pi \times I_{T(AV)}, T_J=T_J \text{ Max}$		
$V_{T(TO)2}$	High level value of threshold voltage	0.92		$(I > \pi \times I_{T(AV)}), T_J=T_J \text{ Max}$		
R_{t1}	Low level value of on-state slope resistance	0.88	mΩ	$(16.7\% \times I_{T(AV)} < I < \pi \times I_{T(AV)}, T_J=T_J \text{ Max}$		
R_{t2}	High level value of on-state slope resistance	0.81		$(I > \pi \times I_{T(AV)}), T_J=T_J \text{ Max}$		
V_{TM}	Max. on-state voltage	1.55	V	$I_{PK}=79A, T_J=25^\circ\text{C}$		
I_H	Maximum holding current	600	mA	$T_J=25^\circ\text{C}$, Anode supply 6V, resistive load		
I_L	Latching current	100				

Symbol	Charteristic	KP500A	Units	Conditions
di/dt	Critical rate of rise of on-state current $V_{DRM} \leq 600V$ $V_{DRM} \leq 800V$ $V_{DRM} \leq 1000V$ $V_{DRM} \leq 1600V$	1000	A/us	$T_J = T_J \text{ max.}, V_{DM} = V_{DRM}$ $, 15 \Omega, t_q = 6\mu s,$ $t_r = 0.1\mu s \text{ max}$ $I_{TM} = (2 \times \text{rated di/dt}) A$
t_{qt}	Typical turn-on time	1.0		$T_J = 25^\circ C$
t_{rr}	Typical reverse recovery time	100	us	$A_t = V_{DRM}/V_{RRM}, T_J = 125^\circ C$ $T_J = T_J \text{ max,}$ $I_{TM} = I_{T(AV)}, t_q > 200\mu s, di/dt = -10A/\mu s$
t_q	Typical turn-off time	110		$T_J = T_J \text{ max, } I_{TM} = I_{T(AV)}, t_q > 200\mu s, V_R = 100V$ $di/dt = -10A/\mu s, dv/dt = -20A/\mu s, V_{DM} = 67\% V_{DRM}$ $0V-100W$
dv/dt	Max. critical rate of rise of off-state voltage	500	V/us	$T_J = T_J \text{ max, } V_{DM} = 67\% V_{DRM}$
I_{DRM}, I_{RRM}	Gate trigger current	30	mA	$T_J = T_J \text{ max, rated } V_{DRM}/V_{RRM} \text{ applied}$
P_{GM}	Gate trigger voltage	10	W	$T_J = T_J \text{ max}$
$P_{G(AV)}$	Stored temperature	2.0	W	$T_J = T_J \text{ max}$
I_{GM}	Thermal impedance node to the shell	3.0	A	$T_J = T_J \text{ max}$
+ V_{GM}	Thermal impedance (shell to powder)	20	V	
- V_{GM}	Mounting torque	5	V	
I_{GT}	Approximate weight	180 90 40	mA	$T_J = -40^\circ C$ $T_J = 25^\circ C$ $T_J = 125^\circ C$
V_{GT}	Critical rate of rise of on-state current $V_{DRM} \leq 600V$ $V_{DRM} \leq 800V$ $V_{DRM} \leq 1000V$ $V_{DRM} \leq 1600V$	2.9 1.8 1.2	V	$T_J = -45^\circ C$ $T_J = 25^\circ C$ $T_J = 125^\circ C$
I_{GD}	Typical turn-on time	10	mA	$T_J = T_J \text{ max, } V_{DRM} = 67\% V_{DRM}$
V_{GD}	Typical reverse recovery time	0.25	V	$T_J = T_J \text{ max, } V_{DRM} = 67\% V_{DRM}$
T_J	Typical turn-off time	-40-125	$^\circ C$	
T_{stg}	Max. critical rate of rise of off-state voltage	-40-125	$^\circ C$	
$R_{th(j-c)}$	Gate trigger current	0.195	K/W	
$R_{th(c-s)}$	Gate trigger voltage	0.08	K/W	
T	Stored temperature	15.5	Nm	
W_t	Thermal impedance node to the shell	327	g	

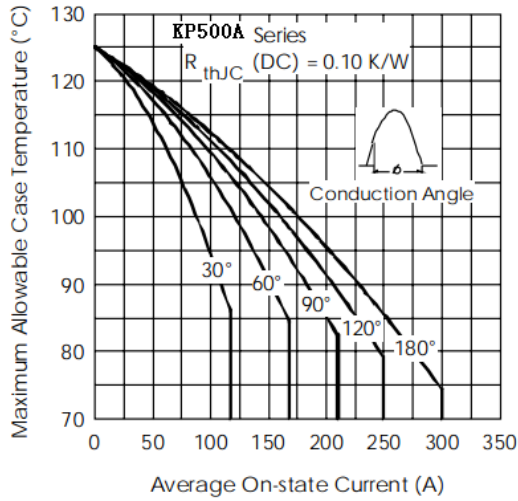

Fig. 1 - Current Ratings Characteristics

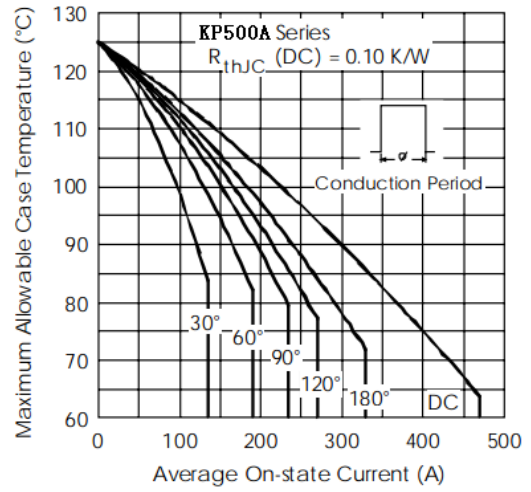

Fig. 2 - Current Ratings Characteristics

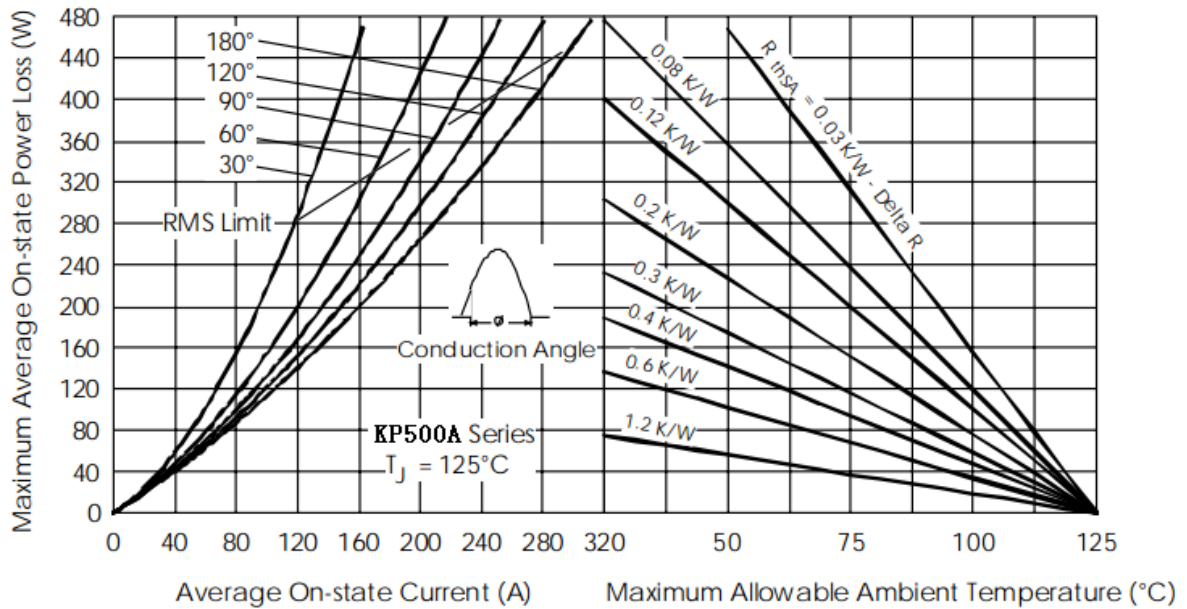

Fig. 3 - On-state Power Loss Characteristics

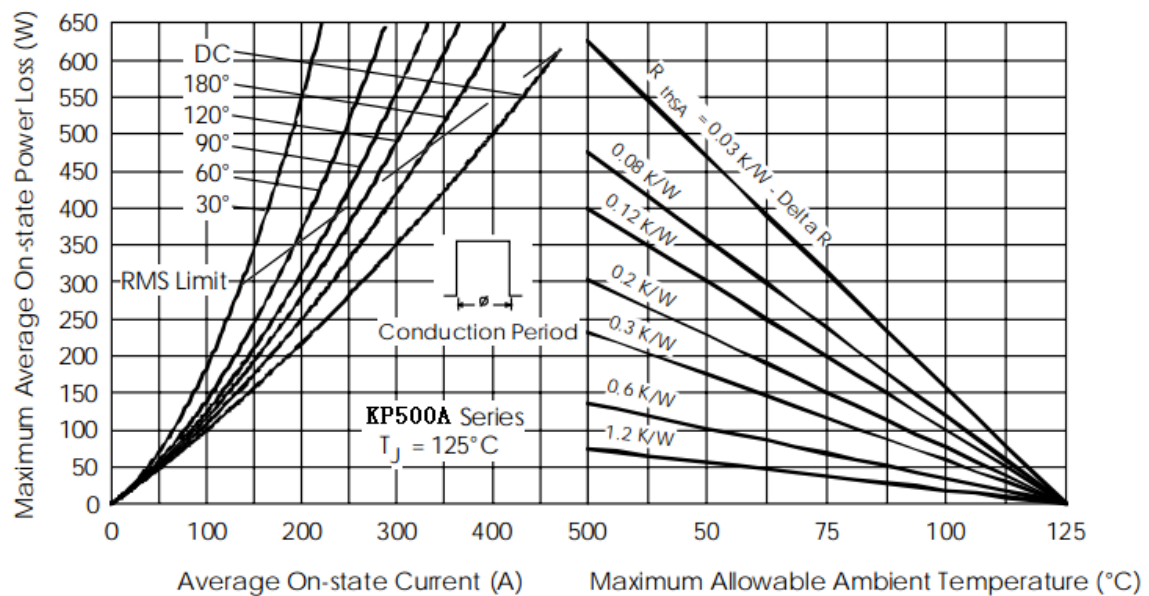

Fig. 4 - On-state Power Loss Characteristics

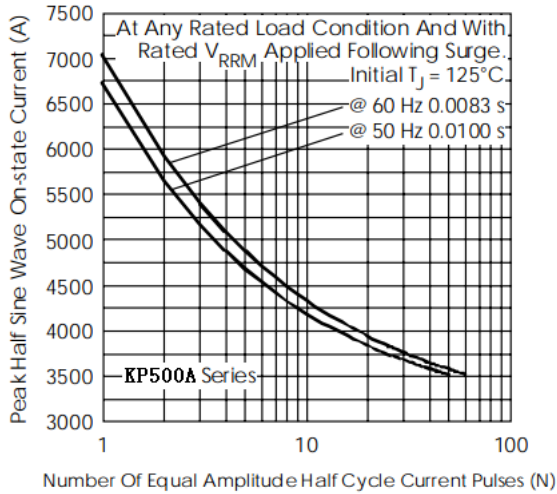

Fig. 5 - Maximum Non-Repetitive Surge Current

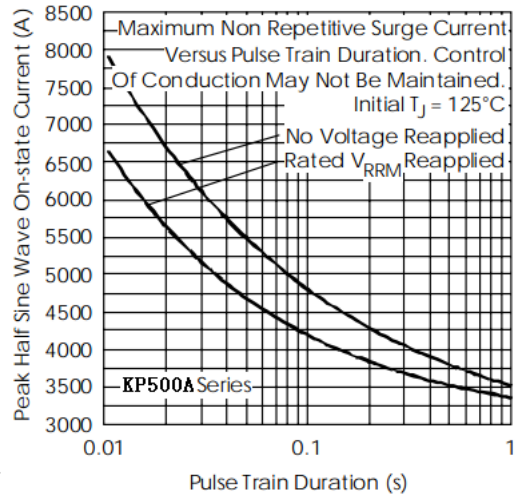

Fig. 6 - Maximum Non-Repetitive Surge Current

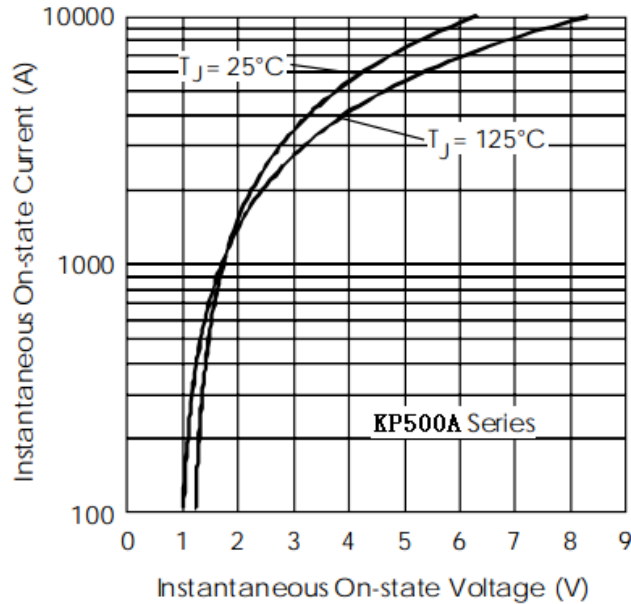

Fig. 7 - On-state Voltage Drop Characteristics

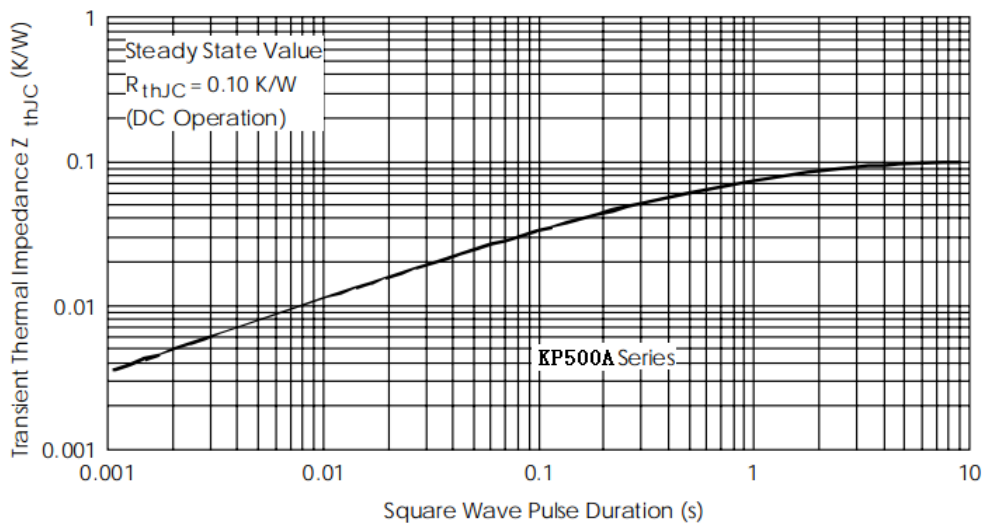
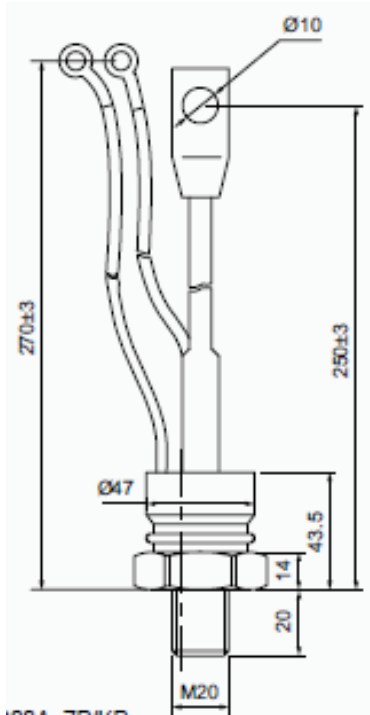

Fig. 8 - Thermal Impedance Z_{thJC} Characteristic

Outline:



1