

**KP500B 特性****Pyroelectric infrared sensor**

型号 Type	KP500B-P
封装 Encapsulation	T0-5
灵敏元面积 Element Size/Type	2.0mm × 1.1mm × Gap 0.9mm Dual,双元
基片材料 Window Material	硅 Si
基片厚度 Window Thickness	0.5mm
窗口尺寸 Window Size	4×3mm
工作波长 Pass Band	5-14 μm (www.tzoic.cn)
平均透过率 Transmittance	>75%
输出信号 Signal [Vp-p]	>2.2V (420° k 黑体1Hz 调制频率 0.3-3.0Hz 带宽 72.5db 增益)
灵敏度 Sensitivity	3300V/W
探测率 (D*) Detectivity	$1.5 \times 10^8$ cmHz <sup>1/2</sup> /W
噪声 Noise (Vp-p)	<200mV (mVp-p) (25°C)
平衡度 Balance	<20%
工作电压 Operating Voltage	2.2-15V
工作电流 Operating Current	8.5-24 μA (V <sub>b</sub> =10V, R <sub>s</sub> =47k Ω, 25°C)
源极电压 Source Voltage	0.3-1.1V (V <sub>b</sub> =10V, R <sub>s</sub> =47k Ω, 25°C)
工作温度 Operating Temperature	-30°C - +70°C
保存温度 Storage Temperature	-40°C - +80°C
视场 Field of View	中心角 138° × 125°

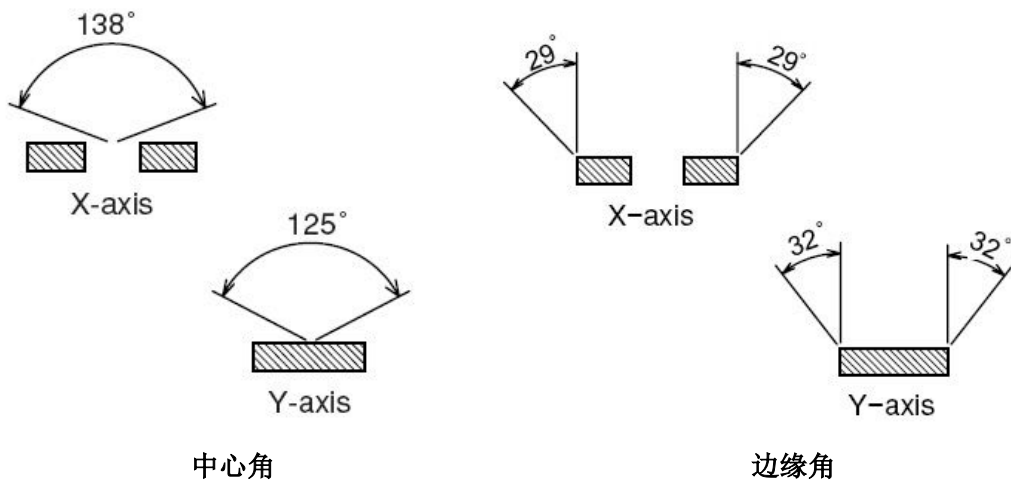

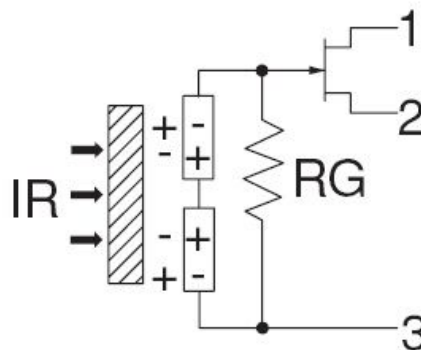
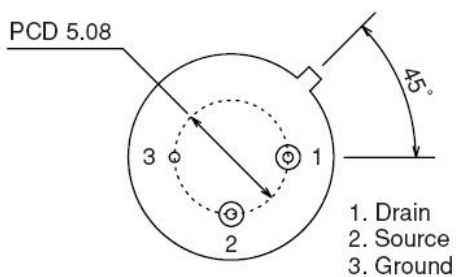
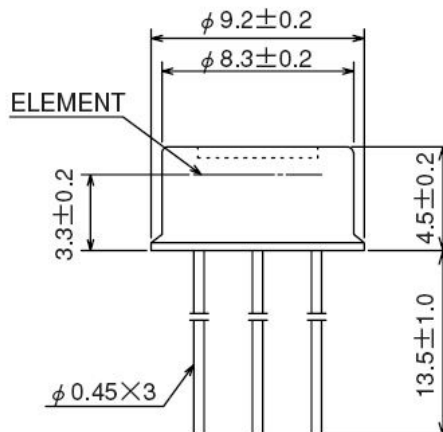
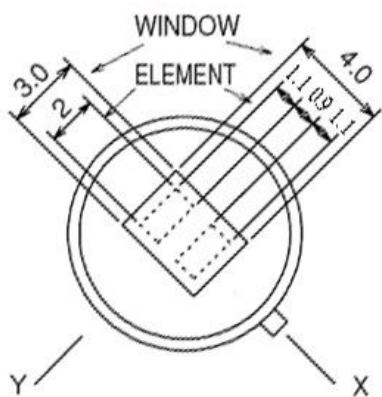

应用电路图见下页:

應用電路

一、基本电路

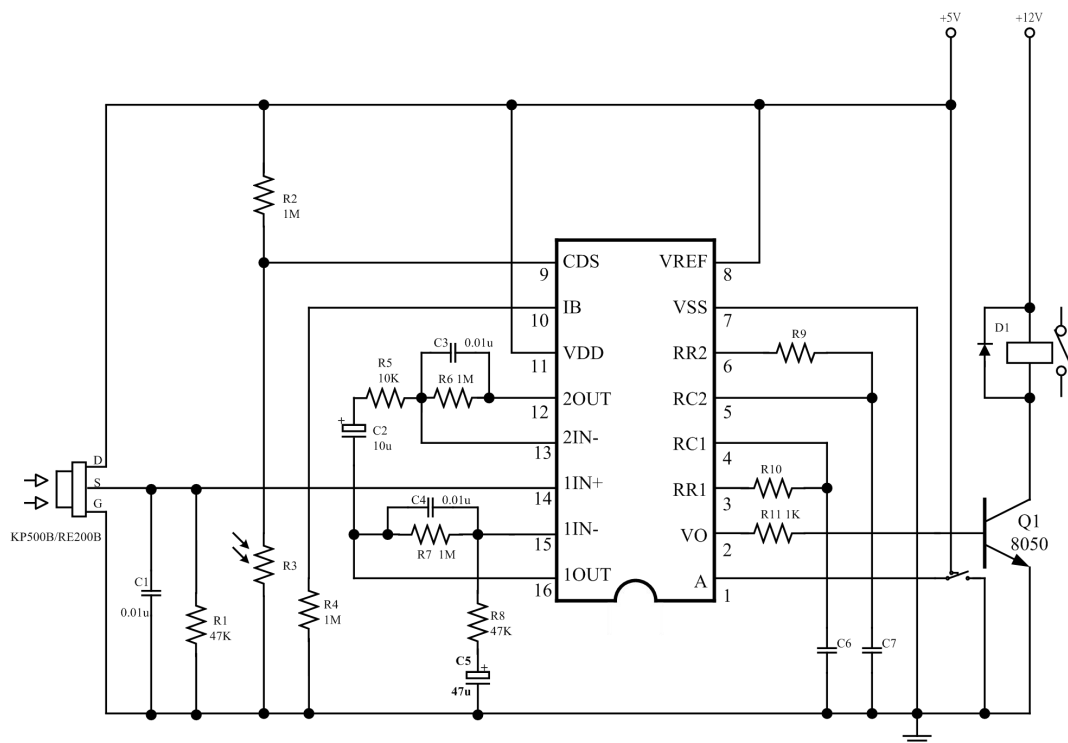

二、DC 电路

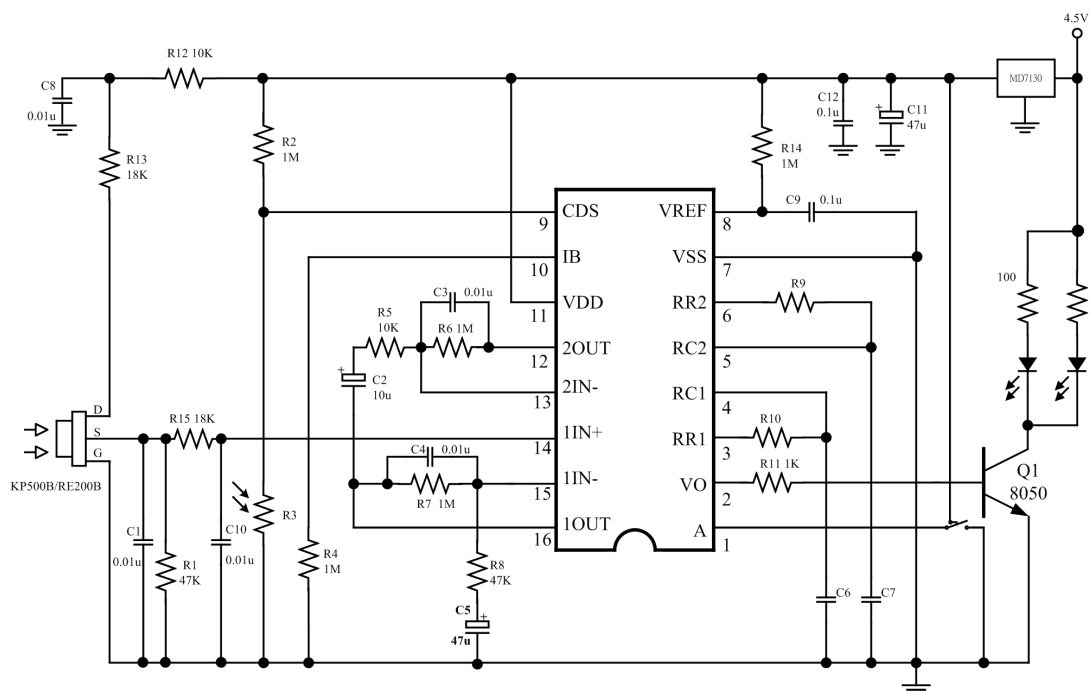

三、AC 电路

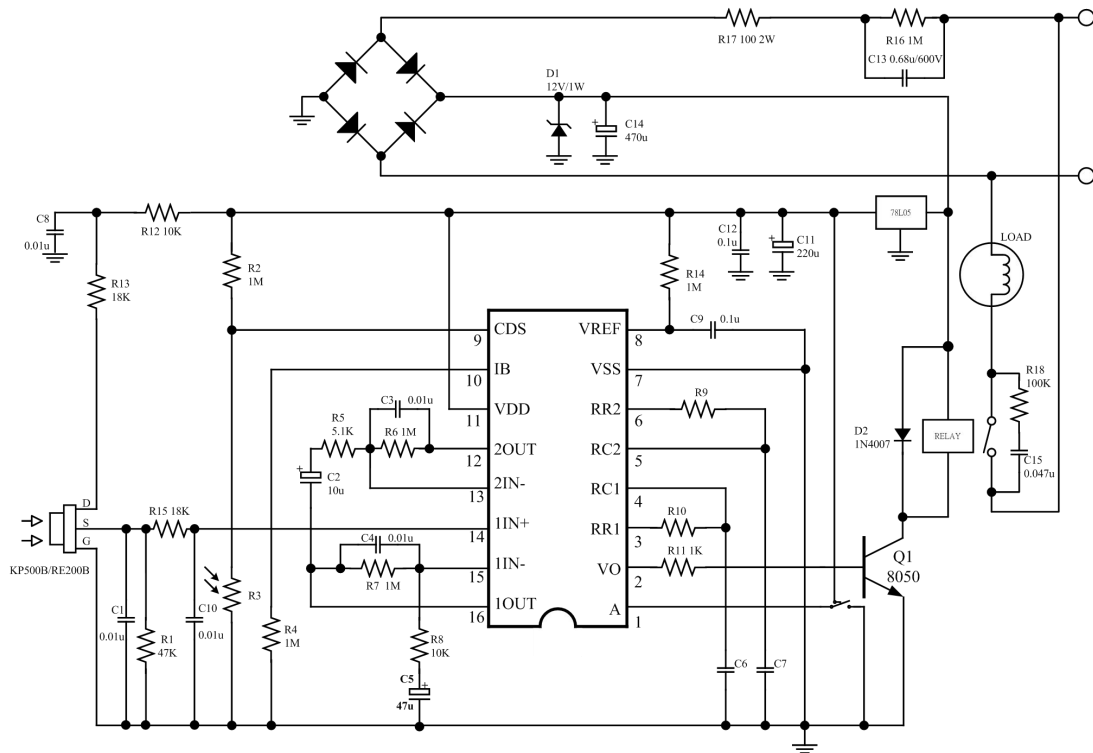

Tx 輸出延遲時間大約值

C6=1000p			C6=0.01u		
R10	F <sub>TX</sub>	T <sub>x</sub>	R10	F <sub>TX</sub>	T <sub>x</sub>
1M	1.8KHz	27.4 秒	100K	1.8KHz	27.4 秒
100K	16.9KHz	2.94 秒	10K	12.7KHz	3.86 秒
10K	116KHz	0.41 秒	1K	48.4KHz	1.5 秒

Ti 輸出封鎖時間大約值

R9	C7	F <sub>Ti</sub>	T <sub>i</sub>
1M	0.01u	189Hz	0.48 秒
1M	0.1u	15.8Hz	3.1 秒

\*产品功能如有更改，恕不另行通知！请查询 <http://www.tzoic.cn>