

High Reliability Photo Coupler

Features

- High current transfer ratio (V_{CEO} : 300V MIN)
(CTR: MIN.600% at $I_F=1\text{mA}$, $V_{ce}=2\text{V}$)
- High isolation voltage between input and output
(Viso: 5000Vrms)
- Compact dual-in-line package
- Available package: DIP / SMD / H

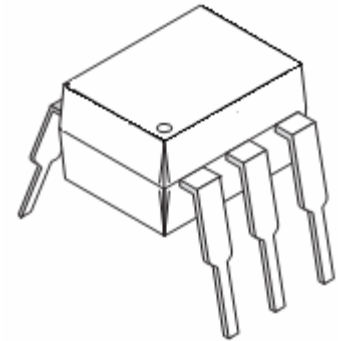

QRCTA16P



Applications

- System appliances, measuring instruments
- Industrial robots
- Copies, automatic vending machines
- Signal transmission between circuits of different potentials and impedances
- Telephone sets
- Copiers, facsimiles
- Interface with various power supply circuits, power distribution boards
- Numerical control machines

Absolute Maximum Ratings (Ta=25°C)

Parameter		Symbol	Rating	Unit
Input	Forward Current	IF	50	mA
	Peak forward current	IFM	1	A
	Reverse voltage	VR	6	V
	Power dissipation	PD	70	mW
Output	Collector-emitter voltage	VCEO	300	V
	Collector-base voltage	VCBO	300	V
	Emitter-base voltage	VEBO	6	V
	Collector current	IC	150	mA
	Collector power dissipation	PC	200	mW
Total power dissipation		Ptot	200	mW
Isolation voltage 1 minute		Viso	5000	Vrms
Operating Temperature		Topr	-30 ~ +100	°C
Storage Temperature		Tstg	-55 ~ +125	°C
Soldering temperature 10 second		Tsol	260	°C

Electro-Optical Characteristics (Ta=25°C)

Parameter		Symbol	Min.	Typ.	Max.	Unit	Condition
Input	Forward Voltage	VF	----	1.2	1.4	V	IF =20mA
	Peak forward voltage	VFM	----	----	3.5	V	IFM =0.5A
	Reverse current	IR	----	----	10	uA	VR =4V
	Terminal capacitance	Ct	----	30	----	pF	V =0, f =1kHz
Output	Collector dark current	ICEO	----	----	1	uA	VCE =200V, IF =0
Transfer Characteristics	Current transfer ratio	CTR	600	----	9000	%	IF =1mA, VCE =2V
	Collector-emitter saturation voltage	VCE(sat)	----	----	1.5	V	IF =20mA, IC =5mA
	Isolation resistance	Riso	5x10 ¹⁰	----	----	ohm	DC500V
	Floating capacitance	Cf	----	0.6	1.0	pF	V =0, f =1MHz
	Cut-off frequency	fc	----	7	----	kHz	VCC=5V, IC =2mA, RL=100ohm
	Response time (Rise)	tr	----	60	300	us	VCE=2V, IC =20mA RL=100ohm
Response time (Fall)	tf	----	50	250	us		

Typical Electro-Optical Characteristics Curves

Fig.1 Current Transfer Ratio vs. Forward Current

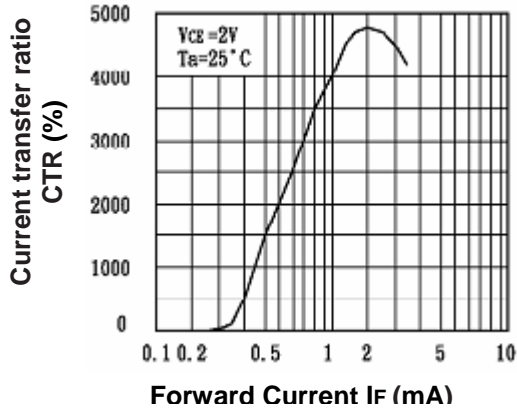

Fig.2 Collector Power Dissipation vs. Ambient Temperature

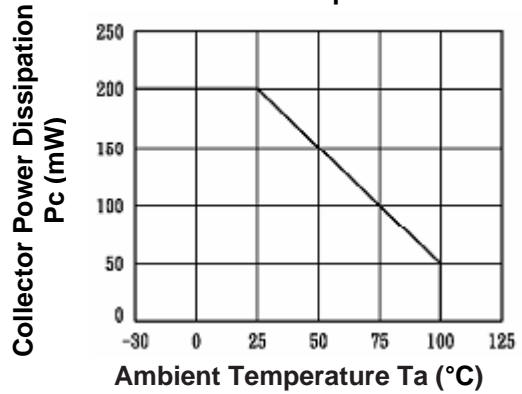

Fig.3 Collector Dark Current vs. Ambient Temperature

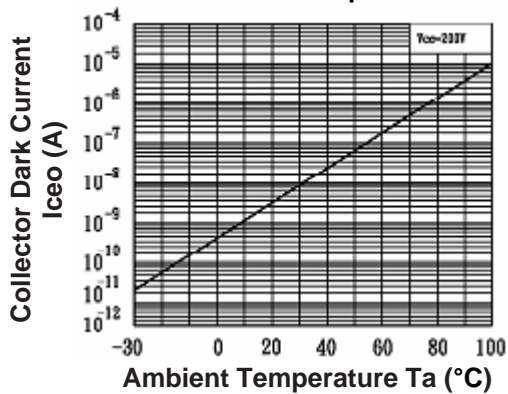

Fig.4 Forward Current vs. Ambient Temperature

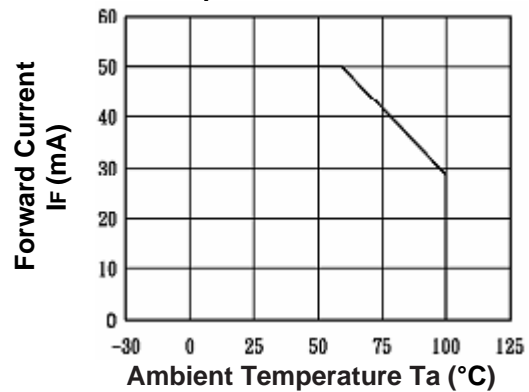

Fig.5 Forward Current vs. Forward Voltage

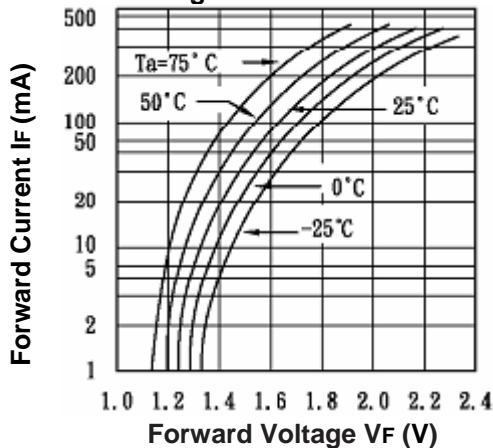

Fig.6 Collector Current vs. Collector Emitter Voltage

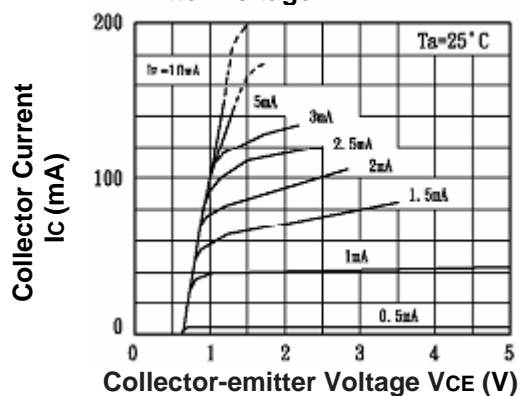

Fig.7 Relative Current Transfer Ratio vs. Ambient Temperature

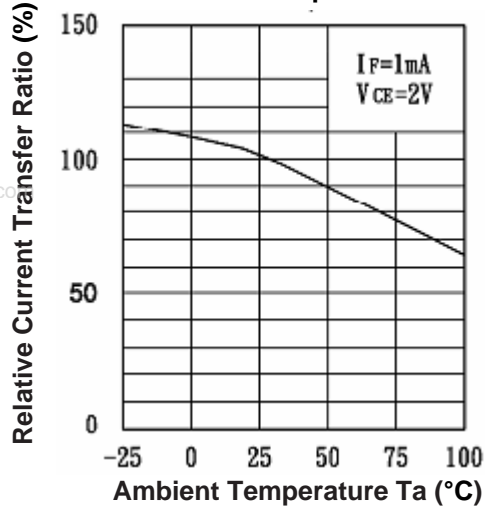

Fig.8 Collector-emitter Saturation Voltage vs. Forward Current

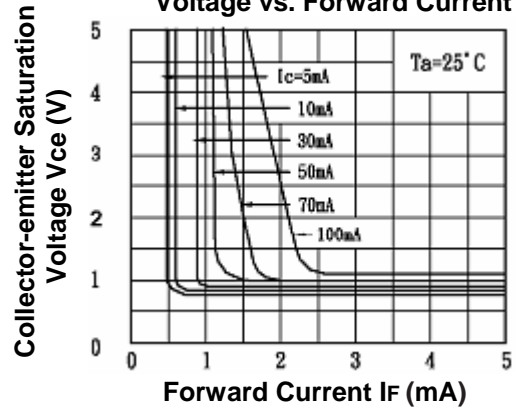
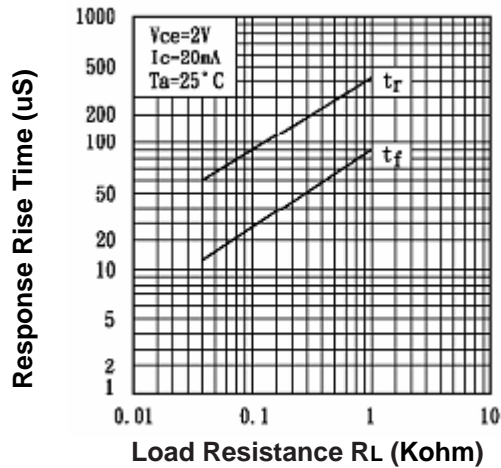

Fig.9 Response Time vs. Load Resistance



Classification table of current transfer ratio is shown below.

Model No.	Rank mark	CTR (%)
*KP5010	A	600 to 2000
KP5010	B	1500 to 4000
KP5010	C	3000 to 6000
*KP5010	D	5000 to 9000
KP5010	E	60 to 9000

*SPECIAL OPTION

Package Dimensions (In mm)

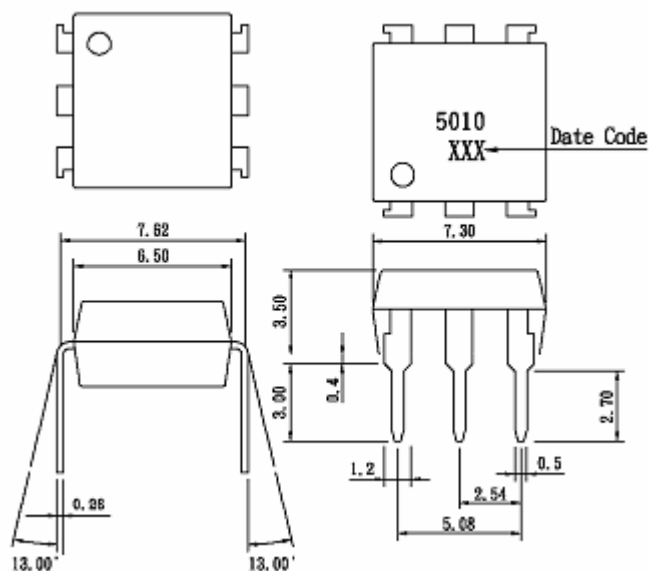

- Note:** 1. Dimensions are in millimeters
2. Tolerances unless dimensions $\pm 0.2\text{mm}$

Schematic: Top View

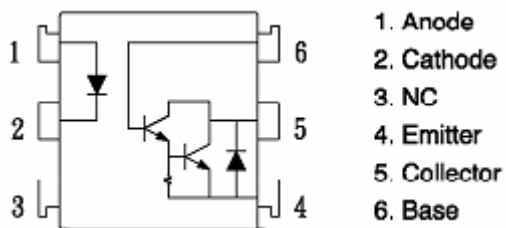

How to contact us

US HEADQUARTERS

28040 WEST HARRISON PARKWAY, VALENCIA, CA 91355-4162

Tel: (800) TAITRON (800) 247-2232 (661) 257-6060

Fax: (800) TAITFAX (800) 824-8329 (661) 257-6415

Email: taitron@taitroncomponents.com

Http://www.taitroncomponents.com

TAITRON COMPONENTS MEXICO, S.A .DE C.V.

BOULEVARD CENTRAL 5000 INTERIOR 5 PARQUE INDUSTRIAL ATITALAQUIA, HIDALGO

C.P. 42970 MEXICO

Tel: +52-55-5560-1519

Fax: +52-55-5560-2190

TAITRON COMPONETS INCORPORATED E REPRESENTAÇÕES DO BRASIL LTDA

RUA DOMINGOS DE MORAIS, 2777, 2.ANDAR, SALA 24 SAÚDE - SÃO PAULO-SP 04035-001

BRAZIL

Tel: +55-11-5574-7949

Fax: +55-11-5572-0052

TAITRON COMPONETS INCORPORATED, SHANGHAI REPRESENTATIVE OFFICE

CROSS REGION PLAZA, 899 LINLING ROAD, SUITE 18C, SHANGHAI, 200030, CHINA

Tel: +86-21-54249942

Fax: +86-21-5424-9931