

FEATURES

- Collector-Emitter Voltage : 55V Min.
- Current Transfer Ratio
CTR : MIN. 50% at $I_F=5\text{mA}$, $V_{CE}=5\text{V}$.
- High Input Output Isolation Voltage : $V_{ISO}=2500V_{rms}$
(UL Recognized : E177885)
- Compact Dual-In-Line Package.
- KPC117 : 1-Channel Type.

APPLICATIONS

- Computer terminals.
- Switching Mode Power Supply.
- System appliances, Measuring instruments.
- Registers, Copiers, Automatic vending machines.
- Electric home appliances such as fan heaters, etc.
- Medical instruments, physical and chemical equipment.
- Signal transmission between circuits of different potentials and impedances.

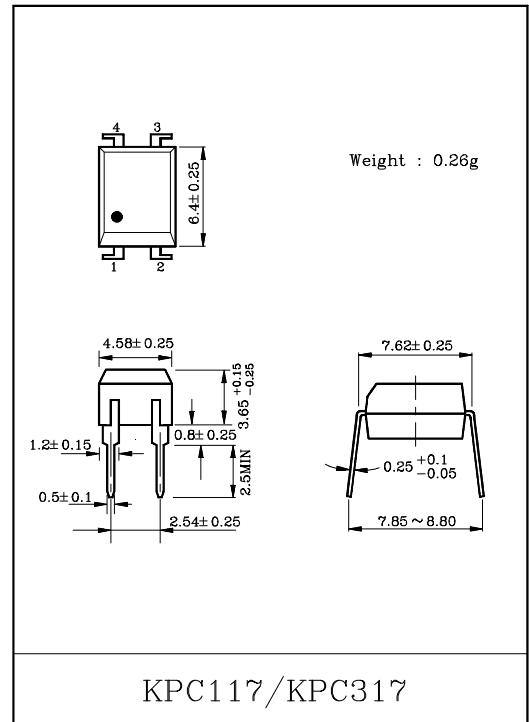

CURRENT TRANSFER RATIO

TYPE	CLASSIFI- CATION *1	CURRENT TRANSFER RATIO (%) (I_C/I_F)		MARKING OF CLASSIFICATION
		$I_F=5\text{mA}$, $V_{CE}=5\text{V}$ $T_a=25^\circ\text{C}$		
		MIN.	MAX.	
KPC117	(None)	50	600	BLANK, Y, Y · G, G · , B, B · , GB
	Rank Y	50	150	Y, Y ·
	Rank GRL	100	200	G
	Rank GRH	150	300	G ·
	Rank GR	100	300	G, G ·
	Rank YG	50	300	Y, Y · , G, G ·
	Rank BL	200	600	B, B ·
	Rank GB	100	600	G, G · , B, B · , GB

PIN CONFIGURATIONS (TOP VIEW)

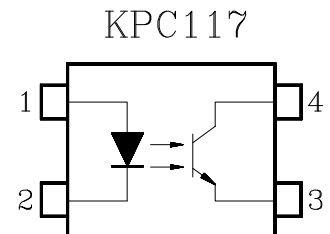

- 1: ANODE
- 2: CATHODE
- 3: EMITTER
- 4: COLLECTOR

Note : Application type name for certification test,
please use standard product type name, i.e.
KPC117(GB) : KPC117

KPC117

MAXIMUM RATINGS (Ta=25°C)

CHARACTERISTIC		SYMBOL	RATING	UNIT
L E D	Forward Current	I_F	70	mA
	Forward Current Derating	$\Delta I_F/^\circ\text{C}$	-0.7 (Ta \geq 39°C)	mA/°C
	Pulse Forward Current	I_{FP}	1 (100 μ pulse, 100pps)	A
	Reverse Voltage	V_R	5	V
	Junction Temperature	T_j	125	°C
D E T E C T O R	Collector-Emitter Voltage	V_{CEO}	55	V
	Emitter-Collector Voltage	V_{ECO}	7	V
	Collector Current	I_C	50	mA
	Collector Power Dissipation	P_C	150	mW
	Collector Power Dissipation Derating (Ta \geq 25°C)	$\Delta P_C/^\circ\text{C}$	-1.5	mW/°C
	Junction Temperature	T_j	125	°C
Storage Temperature Range		T_{stg}	-55~125	°C
Operating Temperature Range		T_{opr}	-55~100	°C
Lead Soldering Temperature		T_{sold}	260 (10 sec.)	°C
Total Package Power Dissipation		P_T	250	mW
Total Package Power Dissipation Derating (Ta \geq 25°C)		$\Delta P_T/^\circ\text{C}$	-2.5	mW/°C
Isolation Voltage		BV_S	2500 (AC, 1 min., RH \leq 60%)	V_{rms}

KPC117

INDIVIDUAL ELECTRICAL CHARACTERISTICS (Ta=25°C)

CHARACTERISTIC		SYMBOL	TEST CONDITION	MIN.	TYP.	MAX.	UNIT
L E D	Forward Voltage	V_F	$I_F=10\text{mA}$	1.0	1.15	1.3	V
	Reverse Current	I_R	$V_R=5\text{V}$	-	-	10	μA
	Capacitance	C_T	$V=0, f=1\text{MHz}$	-	30	-	pF
D E T E C T O R	Collector-Emitter Breakdown Voltage	$V_{(BR)CEO}$	$I_C=0.5\text{mA}$	55	-	-	V
	Emitter-Collector Breakdown Voltage	$V_{(BR)ECO}$	$I_E=0.1\text{mA}$	7	-	-	V
	Collector Dark Current	I_{CEO}	$V_{CE}=24\text{V}$	-	10	100	nA
			$V_{CE}=24\text{V}, T_a=85^\circ\text{C}$	-	2	50	μA
Capacitance (Collector to Emitter)	C_{CE}	$V=0, f=1\text{MHz}$	-	10	-	pF	

COUPLED ELECTRICAL CHARACTERISTICS (Ta=25°C)

CHARACTERISTIC	SYMBOL	TEST CONDITION	MIN.	TYP.	MAX.	UNIT
Current Transfer Ratio	I_C/I_F	$I_F=5\text{mA}, V_{CE}=5\text{V}$ Rank GB	50	-	600	%
			100	-	600	
Saturated CTR	I_C/I_F (sat)	$I_F=1\text{mA}, V_{CE}=0.4\text{V}$ Rank GB	-	60	-	%
			30	-	-	
Collector-Emitter Saturation Voltage	$V_{CE}(\text{sat})$	$I_C=2.4\text{mA}, I_F=8\text{mA}$	-	-	0.4	V

ISOLATION CHARACTERISTICS (Ta=25°C)

CHARACTERISTIC	SYMBOL	TEST CONDITION	MIN.	TYP.	MAX.	UNIT
Capacitance (Input to Output)	C_S	$V_S=0, f=1\text{MHz}$	-	0.8	-	pF
Isolation Resistance	R_S	$V_S=500\text{V}, \text{R.H.} \leq 60\%$	-	10^{11}	-	Ω
Isolation Voltage	BV_S	AC, 1 minute	2500	-	-	Vrms

KPC117

SWITCHING CHARACTERISTICS (Ta=25°C)

CHARACTERISTIC	SYMBOL	TEST CONDITION	MIN.	TYP.	MAX.	UNIT
Rise Time	t_r	$V_{CC}=10V$ $I_C=2mA$ $R_L=100\Omega$	-	2	-	μs
Fall Time	t_f		-	3	-	
Turn-on Time	t_{on}		-	3	-	
Turn-off Time	t_{OFF}		-	3	-	
Turn-on Time	t_{on}	$R_L=1.9k\Omega$ (Fig.1) $V_{CC}=5V, I_F=16mA$	-	2	-	μs
Storage Time	t_s		-	15	-	
Turn-off Time	t_{OFF}		-	25	-	

RECOMMENDED OPERATING CONDITIONS

CHARACTERISTIC	SYMBOL	MIN.	TYP.	MAX.	UNIT
Supply Voltage	V_{CC}	-	5	24	V
Forward Current	I_F	-	16	20	mA
Collector Current	I_C	-	1	10	mA
Operating Temperature	T_{OPR}	-25	-	85	°C

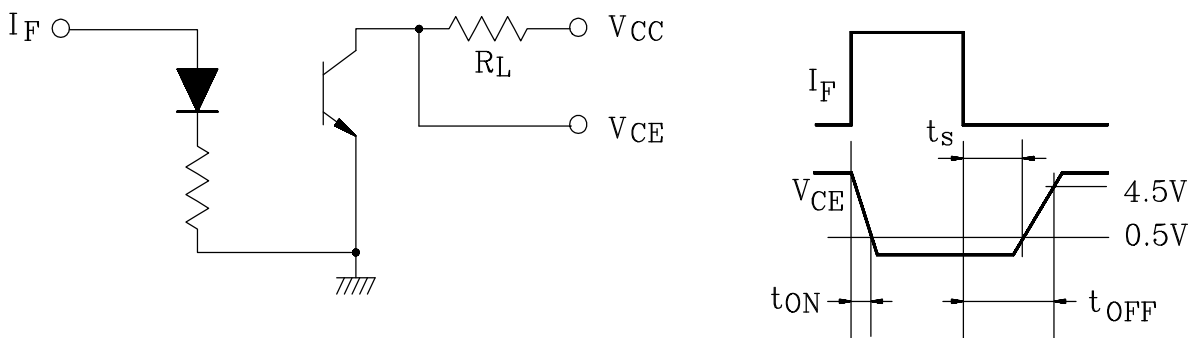
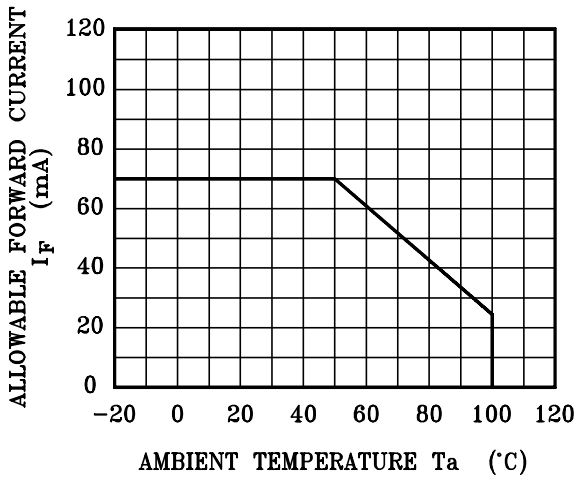

Fig.1 Switching Time Test Circuit

KPC117

$I_F - T_a$



$P_C - T_a$

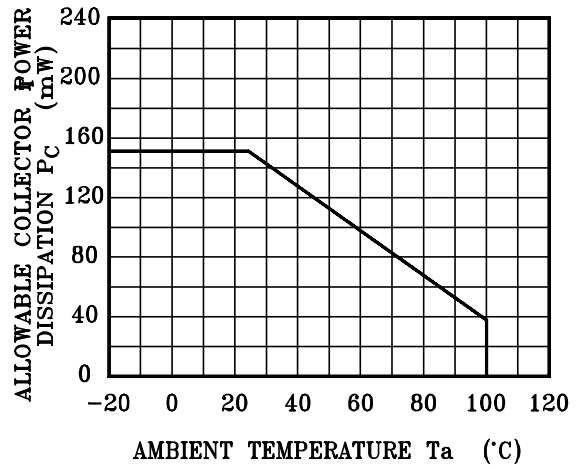

$I_{FP} - D_R$

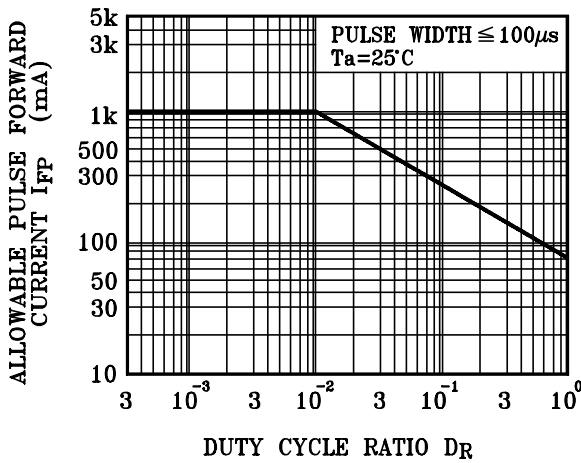

$I_F - V_F$

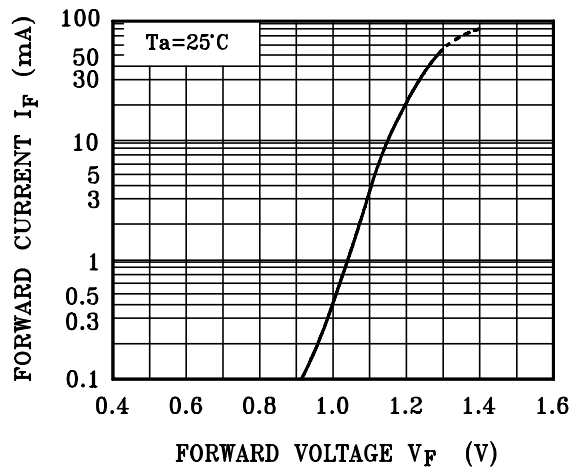

$\Delta V_F / \Delta T_a - I_F$

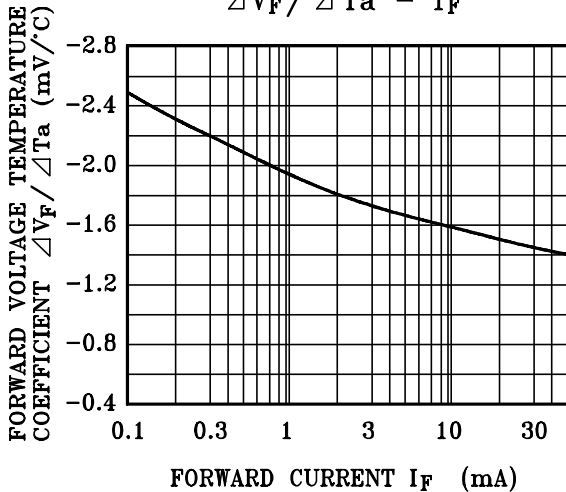

$I_{FP} - V_{FP}$

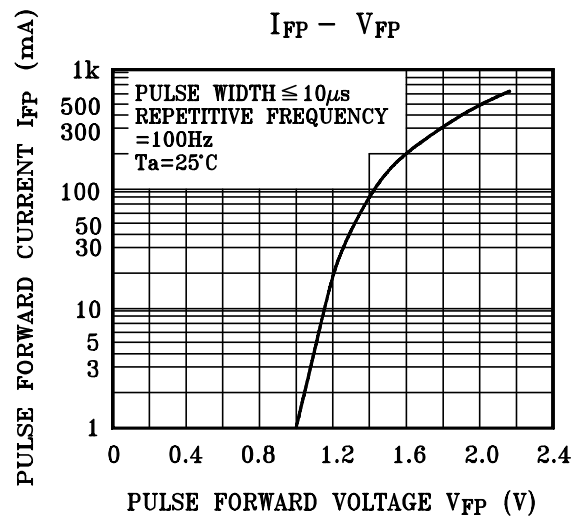

KPC117

$I_{CE0} - T_a$

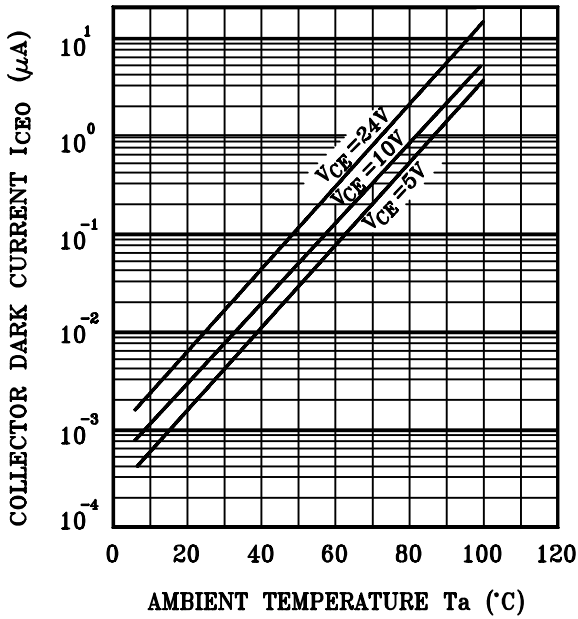

$I_C - V_{CE}$

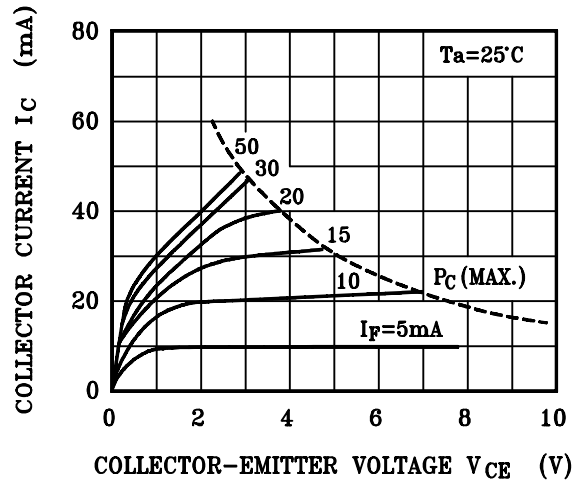

$I_C - V_{CE}$

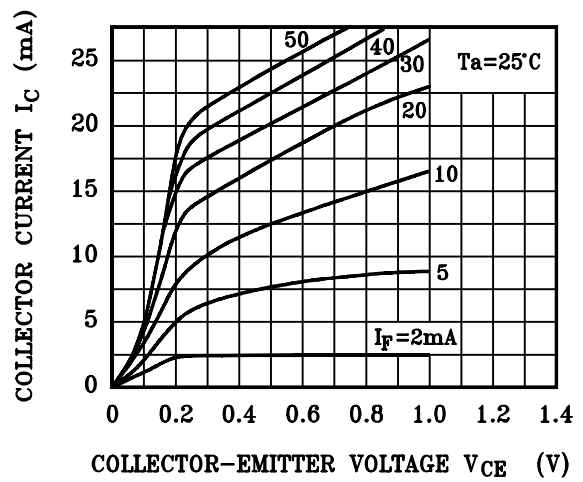

$I_C - I_F$

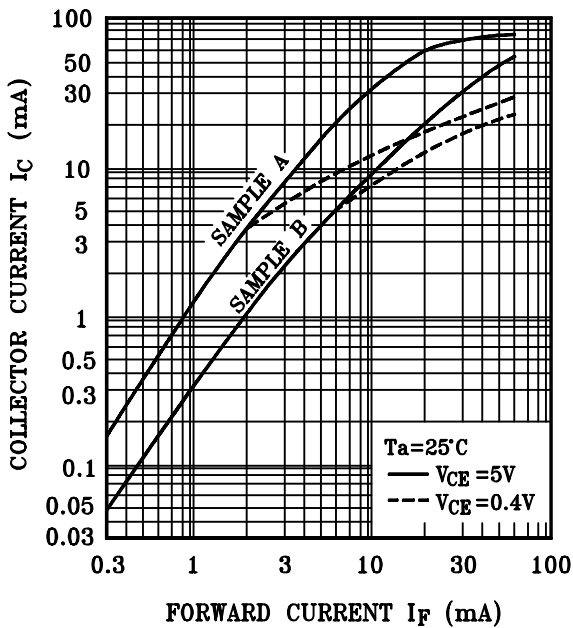

$I_C/I_F - I_F$

