

PRODUCT SPECIFICATION

DATE:2/17/2005

cosmo ELECTRONICS CORPORATION	Photolink :	NO.60F00008	REV.
	KPLT1320A	SHEET 1 OF 5	1

FIBER OPTIC TRANSMITTING MODULE FOR DIGITAL AUDIO EQUIPMENT

Features

- TTL interface.
- LED is driven by differential circuit.
- A Self-tapping hole for easy attachment to audio Equipment panels.

Applications

- Audio equipment.
- DVD player.
- Automobile.

Outline Dimensions

(Unit:mm)

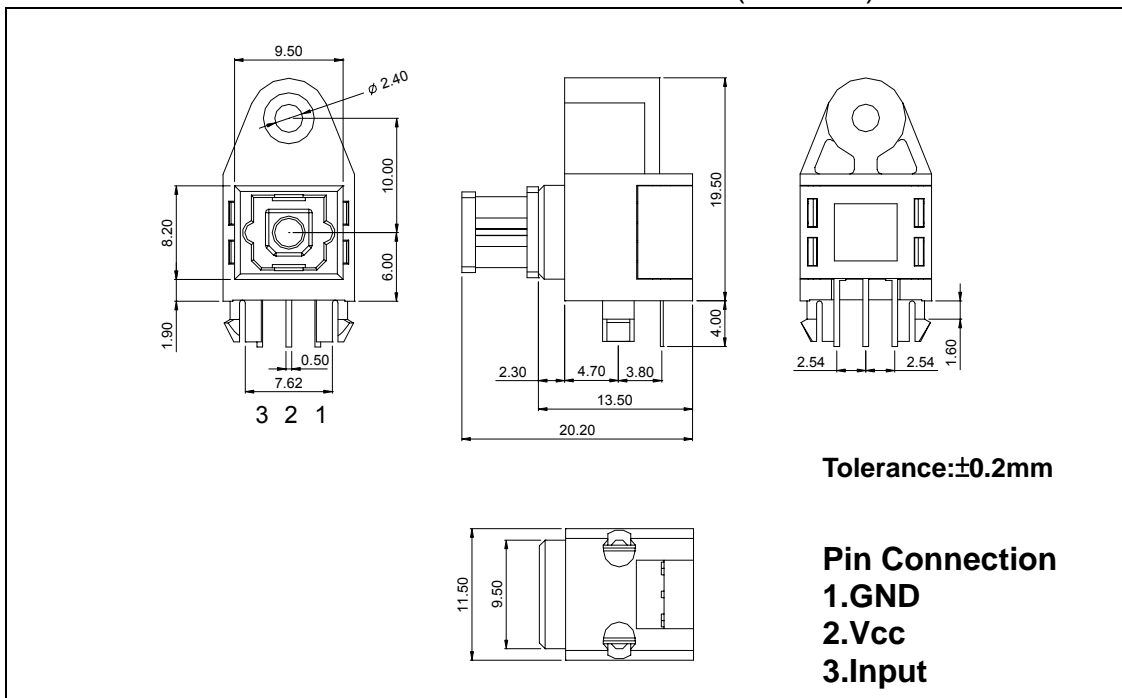

PRODUCT SPECIFICATION

DATE: 2/17/2005

cosmo ELECTRONICS CORPORATION	Photolink : KPLT1320A	NO.60F00008	REV.
		SHEET 2 OF 5	1

1. Maximum Ratings (Ta=25°C)

Parameter	Symbol	Rating	Unit
Storage Temperature	T _{stg}	-40~80	°C
Operating Temperature	T _{opr}	-20~70	°C
Power Dissipation	P _{max}	120	mW
Supply Voltage	V _{CC}	-0.5~7	V
Input Voltage	V _{IN}	-0.5~V _{CC} +0.5	V
Soldering Temperature	T _{sol}	260 ^(Note 1)	°C

Note 1 : Soldering time \leq 10 seconds (At a distance of 1 mm from the package) .

2. Recommended Operating Conditions

Parameter	Symbol	Min	Typ.	Max	Unit
Supply Voltage	V _{CC}	4.75	5.0	5.25	V
High-Level Input Voltage	V _{IH}	2.0	-	V _{CC}	V
Low-Level Input Voltage	V _{IL}	0	-	0.8	V

3. Electrical and Optical Characteristics (Ta=25°C , V_{CC}=5V)

Parameter	Symbol	Condition	Min	Typ.	Max	Unit
Data Rate		NRZ Signal ^(Note 2)	DC	-	13.2	Mb/s
Transmission Distance		Using APF ^(Note 3)	0.2	-	5	m
Fiber Output Power ^(Note 4)	P _f		-21	-	-15	dBm
Peak Emission Wavelength	λ_p		630	650	690	nm
Current Consumption	I _{CC}		-	-	13	mA
High Level Input Voltage	V _{IH}		2.0	-	-	V
Low Level Input Voltage	V _{IL}		-	-	0.8	V
Low->High Propagation delay time	t _{PLH}				150	ns
High -> Low Propagation delay time	t _{PHL}				150	ns
Pulse Width Distortion	Δtw	6Mbps NRZ Signal	-25	-	25	ns
Jitter Time	Δtj				25	ns

Note 2 : LED is on when input signal is high, and off when it is low.

The duty factor must be maintained between 25 to 75%.

Note 3 : All Plastic Fiber (970 / 1000nm) .

Note 4 : Measure with a standard optical fiber, peak value.

PRODUCT SPECIFICATION

DATE:2/17/2005

cosmo ELECTRONICS CORPORATION	Photolink : KPLT1320A	NO.60F00008	REV.
		SHEET 3 OF 5	1

4. Measuring method

(1).Measuring method of optical output coupling fiber

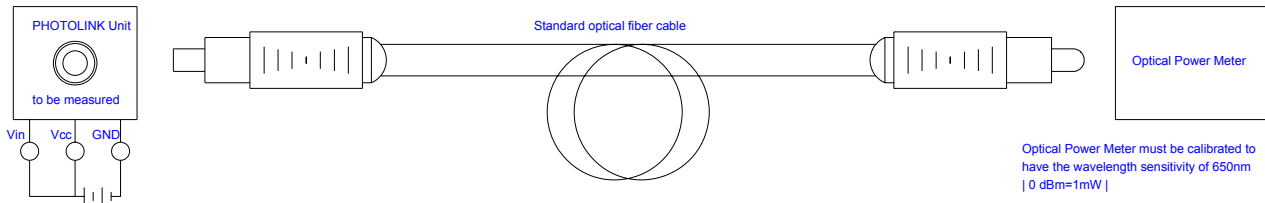

(2).Measuring method of power dissipation current and input voltage

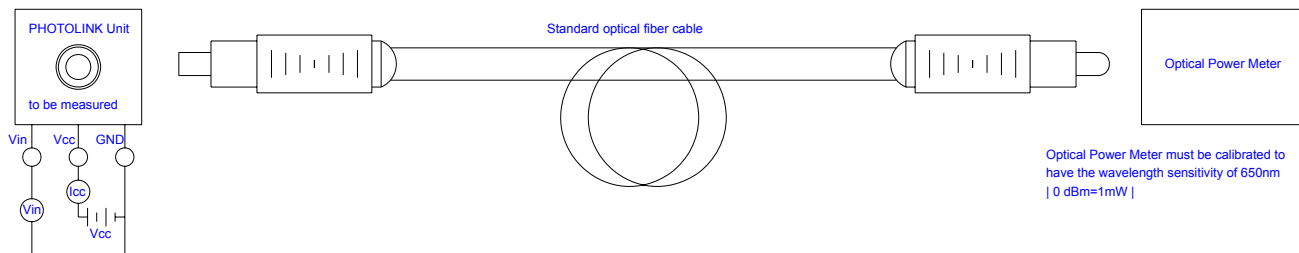

(3).Measuring method of Pulse response

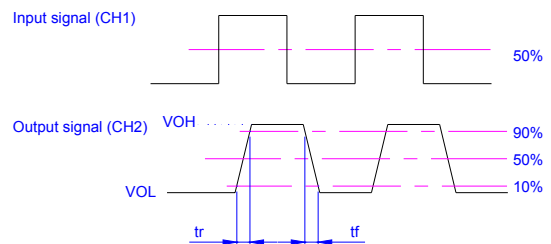
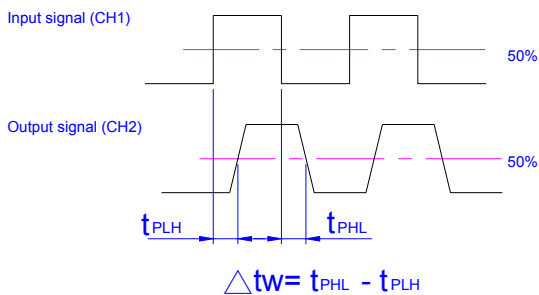
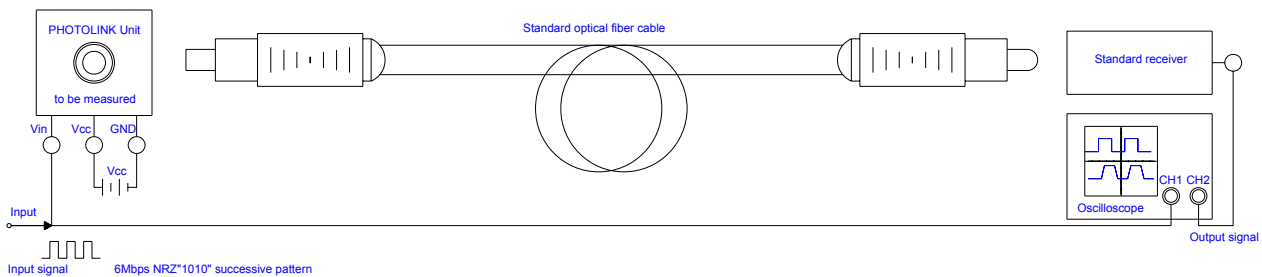

PRODUCT SPECIFICATION

DATE:2/17/2005

cosmo ELECTRONICS CORPORATION	Photolink : KPLT1320A	NO.60F00008	REV.
		SHEET 4 OF 5	1

(4).Measuring method of Jitter

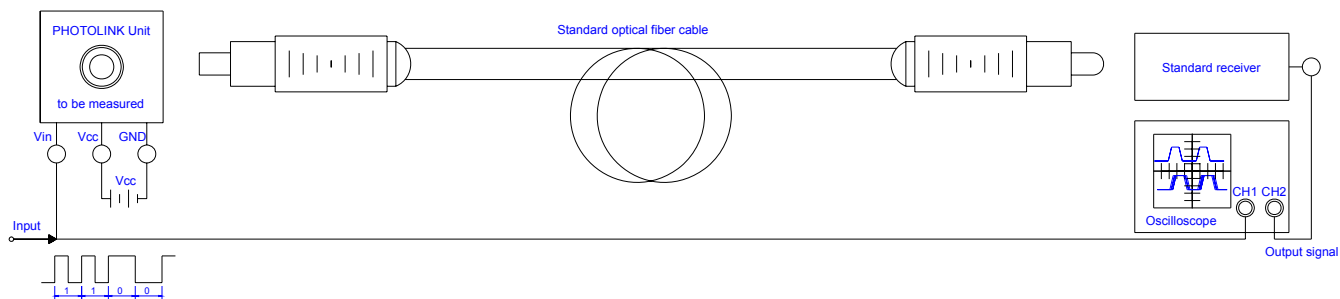

Input signal (CH1)

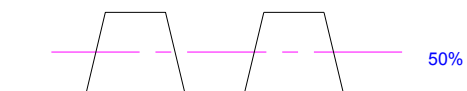

Output signal (CH2)

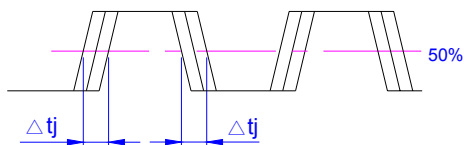

5.Recommended PCB Layout

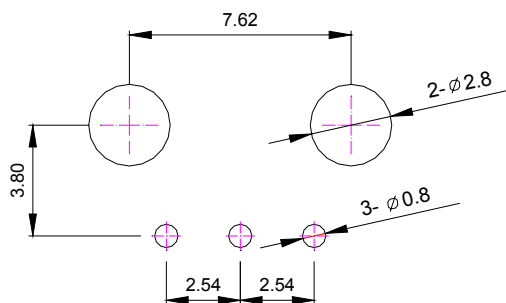

Notes:

1.Unit:mm

2.tolerance:±0.3mm

PRODUCT SPECIFICATION

DATE:2/17/2005

cosmo ELECTRONICS CORPORATION	Photolink : KPLT1320A	NO.60F00008 SHEET 5 OF 5	REV. 1
---	---------------------------------	-----------------------------	-----------

6.Package Information

Item	Quantity	Total	Size(Long*Width*High)
Tube	50	50 pcs	640*24.4*26.4 mm
Inner Box	20 Tube/Box	1000 pcs	660*156*122 mm
Outer Box	4 Inner Box/Outer Box	4000 pcs	690*342*284 mm

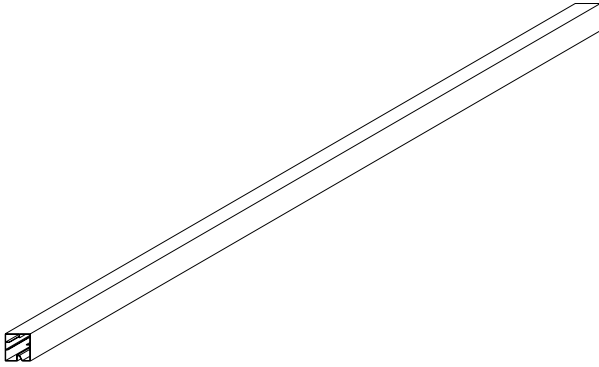

50pcs/Tube

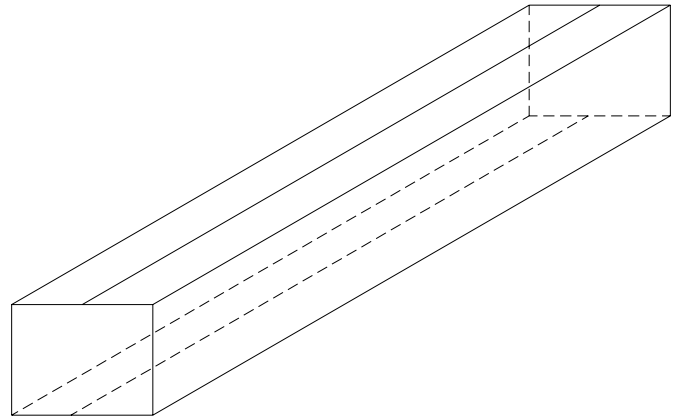

1000pcs/Inner Box

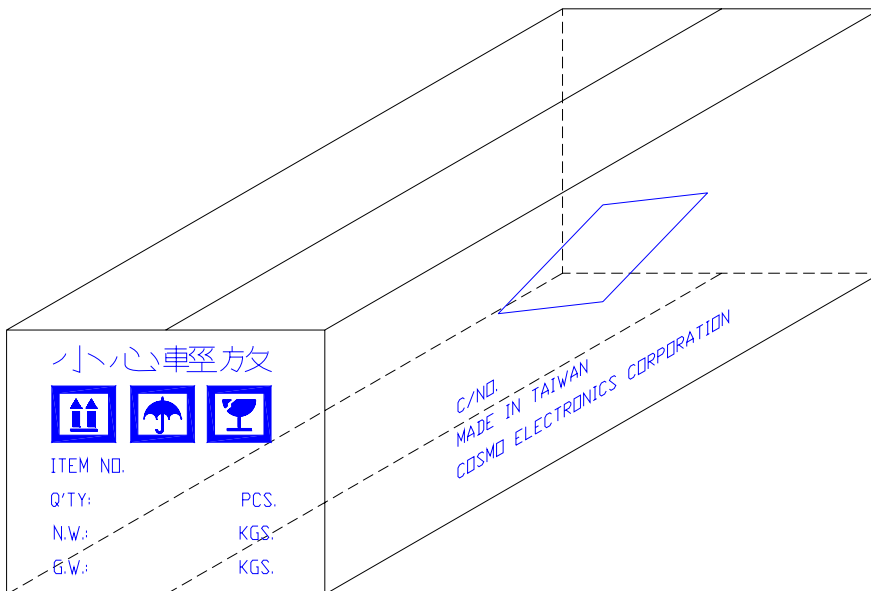

4000pcs/Outer Box