

KPR-3010 series Piezo Telephone Ringer

FREQUENCY RESPONSE

[actual curve of type]

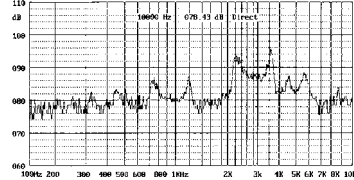

applied voltage: 12Vp-p, 1/2 duty, square wave distance for measurement: 30cm

Model No	KPR-3010
Rated Voltage	12Vp-p Square Wave
Max. Allowable Voltage	30Vp-p Square Wave
Max. Rated Current	4mA at 1.3KHz/12Vp-p Square Wave
Min. Sound Pressure Level	75dB at 1.3KHz/12Vp-p Square Wave/30cm
Resonant Frequency	1.3±0.5KHz
Operating Temperature	-20~+60±æ
Weight	3g

* Value applying at rated voltage



color Black
ABS Housing Material
Lead Terminal

DIMENSIONS

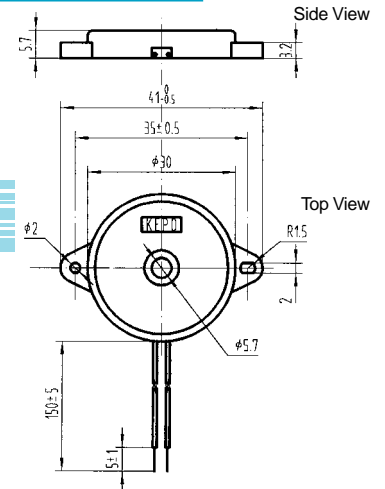

all dimensions are in mm

KPR-3210L series Piezo Telephone Ringer

FREQUENCY RESPONSE

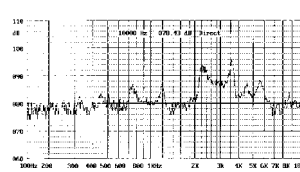

applied voltage: 12 Vp-p, 1/2 duty, square wave distance for mea-

Model No	KPR-3210L
Rated Voltage	12Vp-p
Operating Voltage	3±30Vp-p
Max. Rated Current	15mA at 12Vp-p
Min. Sound Pressure Level	90dB at 12Vp-p/30cm
Resonant Frequency	3.7±0.5KHZ
Capacitance	20nF±30%
Housing Material/Color	ABS/White
Operating Temperature	-20±+60
Store Temperature	-30±+70
Weight	8g

* Value applying at rated voltage



color white
ABS Housing Material
Lead Terminal

DIMENSIONS

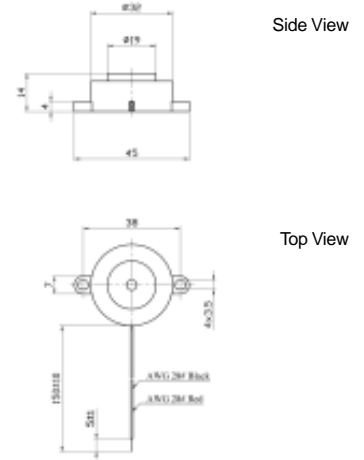

all dimensions are in mm

KPR-3013 series Piezo Telephone Ringer

FREQUENCY RESPONSE

[actual curve of type]

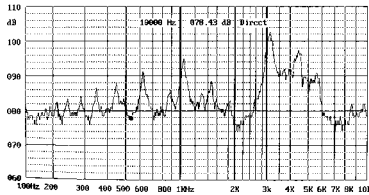

applied voltage: 12Vp-p, 1/2 duty, square wave distance for measurement: 30cm

Model No	KPR-3013
Rated Voltage	12Vp-p Square Wave
Max. Allowable Voltage	30Vp-p Square Wave
Max. Rated Current	4mA at 1.3KHz/12Vp-p Square Wave
Min. Sound Pressure Level	75dB at 1.3KHz/12Vp-p Square Wave/30cm
Resonant Frequency	1.3±0.5KHz
Operating Temperature	-20~+60±æ
Weight	4g

* Value applying at rated voltage

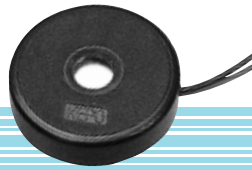

color Black
ABS Housing Material
Lead Terminal

DIMENSIONS

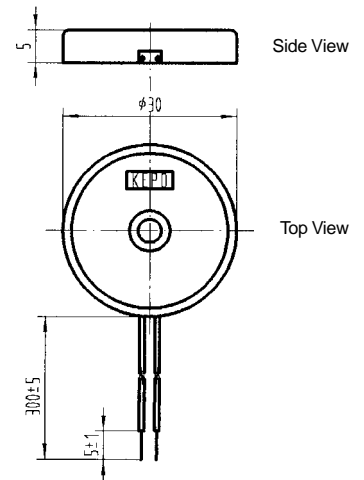

all dimensions are in mm