

Package Dimensions

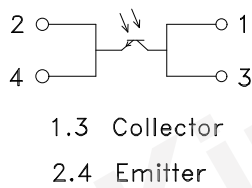
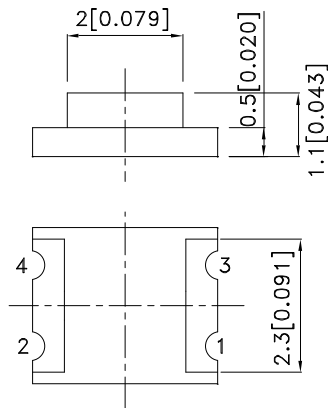
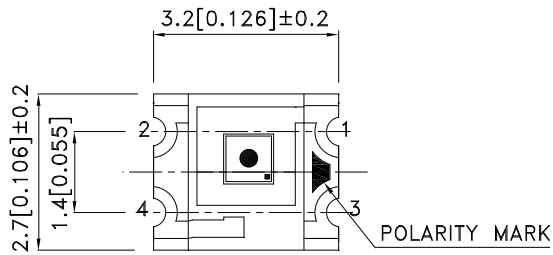

Part Number: KPS-3227SP1C

Description

The KPS-3227SP1C is a NPN silicon phototransistor, It is a good effective solution to the power saving of display backlighting appliances and the device is sensitive to the visible spectrum.

Features

- *Lead-free package.
- *Component in accordance with RoHS.
- *Adapted to human eye responsive.
- *Wide angle of half sensitivity.
- *Moisture sensitivity level : level 3.
- * Package:2000 pcs/ Reel.

Applications

Detection of ambient light to control display backlighting in:

- *Mobile phones
- *PDAs
- *Note books
- *Video cameras

Notes:

1. All dimensions are in millimeters (inches).
2. Tolerance is ± 0.1 (0.004") unless otherwise noted.
3. The specifications, characteristics and technical data described in the datasheet are subject to change without prior notice.



*Absolute Maximum Ratings(Ta=25°C)

Parameter	Symbol	Rating	Unit	Notice
Collector Emitter Voltage	V_{ce0}	60	V	$I_{ce0}=100\mu A$
Emitter-Collector Voltage	V_{eco}	4	V	$I_{eco}=100\mu A$
Operating Temperature	T_{opr}	-40 to +85	°C	-
Storage Temperature	T_{stg}	-40 to +85	°C	-

*Electrical and Optical Characteristics (Ta=25°C)

Parameter	Symbol	Value			Unit	Conditions
		Min.	TYP.	Max.		
Collector Emitter Breakdown Voltage	BVceo	60	-	-	V	I _{ceo} =100μA
Emitter Collector Breakdown Voltage	BVeco	4	-	-	V	I _{eco} =100μA
Collector dark current	I _D	-	10	100	nA	V _{CE} =5V E _V =0Lx
Light Current(1)	I _{PH1}	-	6	-	μA	V _{CE} =5V, E _V =100 Lx ^[1]
Light Current(2)	I _{PH2}	-	130	-	μA	V _{CE} =5V, E _V =1000 Lx ^[1]
Light Current(3)	I _{PH3}	-	950	-	μA	V _{CE} =5V, E _V =1000 Lx ^[2]
Light Current(4)	I _{PH4}	-	420	-	μA	V _{CE} =5V, E _V =1000 Lx ^[3]
Saturation Output Voltage	V _O	4.5	4.7	-	V	V _{CC} =5V, E _V =1000Lx ^[1] , R _L =75KΩ
Peak Wavelength	λ _P	-	580	-	nm	-
Response Wavelength	λ	390	-	700	nm	>10% Response
Collector Emitter Saturation Voltage	V _{CE (sat)}	-	-	0.4	V	I _C =10 mA

Notes:

1. White Fluorescent light (Color Temperature = 6200K) is used as light source.
2. Illuminance by CIE standard illuminant-A/2856K, incandescet lamp.
3. Sunlight (Color Temperature = 4600K) is used as light source.

Fig.1 Illuminance vs. Output Phtocurrent

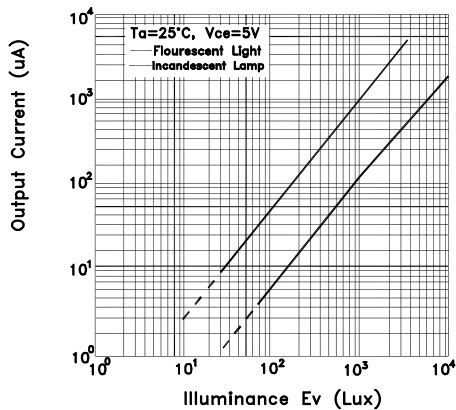
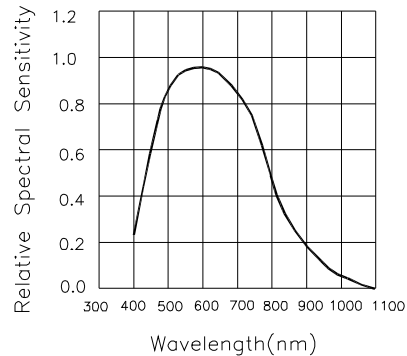
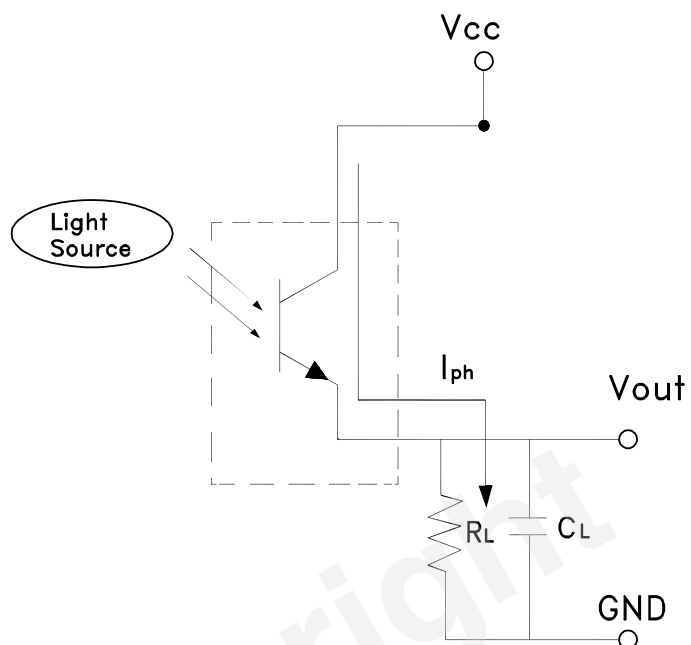

Fig.2 Relative Spectral Responsivity vs. Wavelength



Converting Photocurrent to Voltage



Notes:

1. The output voltage (V_{out}) is the product of photocurrent (I_{PH}) and loading resistor (R_L)
2. A right loading resistor shall be chosen to meet the requirement of maximum ambient light, and output saturation voltage:

$$V_{out(max)} = I_{out(max)} \times R_L \leq V_{out(saturation)} = V_{cc} - 0.3V$$

KPS-3227SP1C

Reflow soldering is recommended and the soldering profile is shown below.
Other soldering methods are not recommended as they might cause damage to the product.

Reflow Soldering Profile For Lead-free SMT Process.

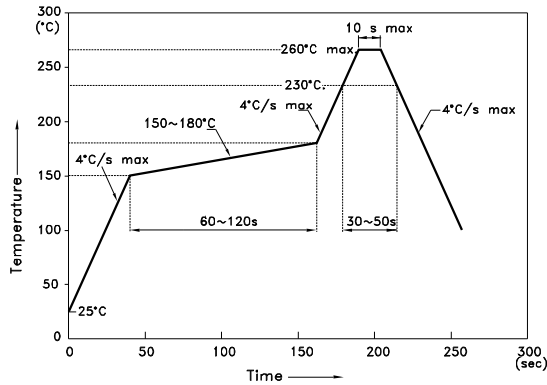

NOTES:

1. We recommend the reflow temperature 245°C(+/-5°C). The maximum soldering temperature should be limited to 260°C.
2. Don't cause stress to the epoxy resin while it is exposed to high temperature.
3. Number of reflow process shall be 2 times or less.

Recommended Soldering Pattern (Units : mm; Tolerance: ± 0.1)

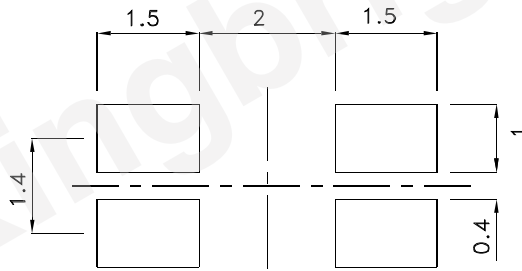

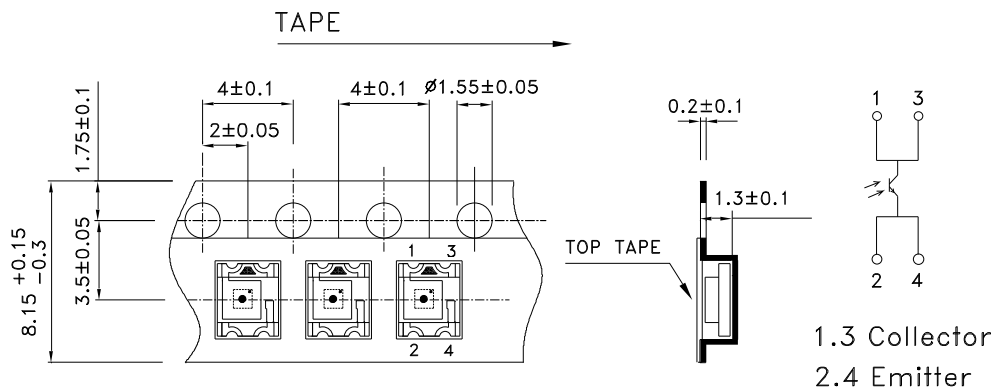

Tape Specifications (Units : mm)

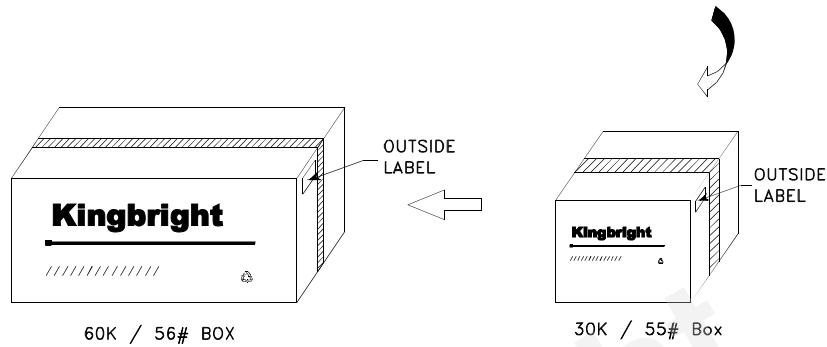
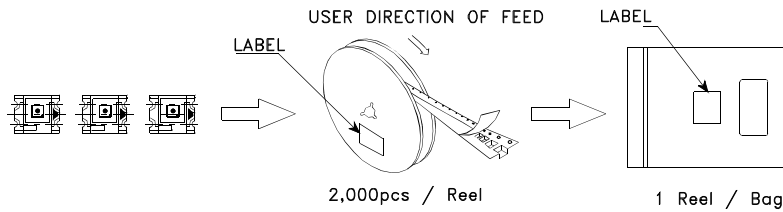

PACKING & LABEL SPECIFICATIONS

KPS-3227SP1C



Kingbright	
P/NO: KPS-3227xxx	
QTY: 2,000 pcs	Q.C. XX-XX-XXXX PASSED
S/N: XXXX	
CODE: XXX	
LOT NO:	
	
RoHS Compliant	

Terms and conditions for the usage of this document

- 1.The information included in this document reflects representative usage scenarios and is intended for technical reference only.
- 2.The part number, type, and specifications mentioned in this document are subject to future change and improvement without notice. Before production usage customer should refer to the latest datasheet for the updated specifications.
- 3.When using the products referenced in this document, please make sure the product is being operated within the environmental and electrical limits specified in the datasheet. If customer usage exceeds the specified limits, Kingbright will not be responsible for any subsequent issues.
- 4.The information in this document applies to typical usage in consumer electronics applications. If customer's application has special reliability requirements or have life-threatening liabilities, such as automotive or medical usage, please consult with Kingbright representative for further assistance.
- 5.The contents and information of this document may not be reproduced or re-transmitted without permission by Kingbright.
- 6.All design applications should refer to Kingbright application notes available at http://www.kingbright.com/application_notes