

● Description

The KPS28010T series is DC-input single channel which contains a light emitting diode optically coupled to a phototransistor. It is packaged in a 4-pin SSOP package. The input-output isolation voltage is rated at 3750Vrms.

● Schematic

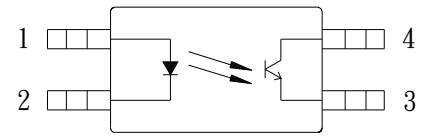

1. Anode
2. Cathode
3. Emitter
4. Collector

● Features

1. Halogen free
2. Pb free and RoHS compliant
3. High isolation voltage (Viso=3750Vrms)
4. Small and thin package (4pin SSOP, pin pitch 1.27mm)
5. Low input current type ($I_F=1.0\text{mA}$)
6. Current transfer ratio
(CTR : 100~600% at $I_F=1.0\text{mA}$, $V_{ce}=5\text{V}$).
7. High collector to emitter voltage ($V_{CE0}=80\text{V}$).
8. High-speed switching $t_r=3\mu\text{s}$ (typ.), $t_f=5\mu\text{s}$ (typ.).
9. MSL class 1
10. Agency Approvals:
 - UL Approved (No. E169586): UL1577
 - c-UL Approved (No. E169586)
 - VDE Approved (No. 40010469): DIN EN60747-5-5
 - FIMKO Approved: EN60065, EN60950
 - SEMKO Approved: EN60065, EN60950
 - CQC Approved: GB8898-2011, GB4943.1-2011

● Applications

- Programmable logic controllers
- Measuring instruments
- Power supply
- Hybrid IC

● **Outside Dimension**

Unit : mm

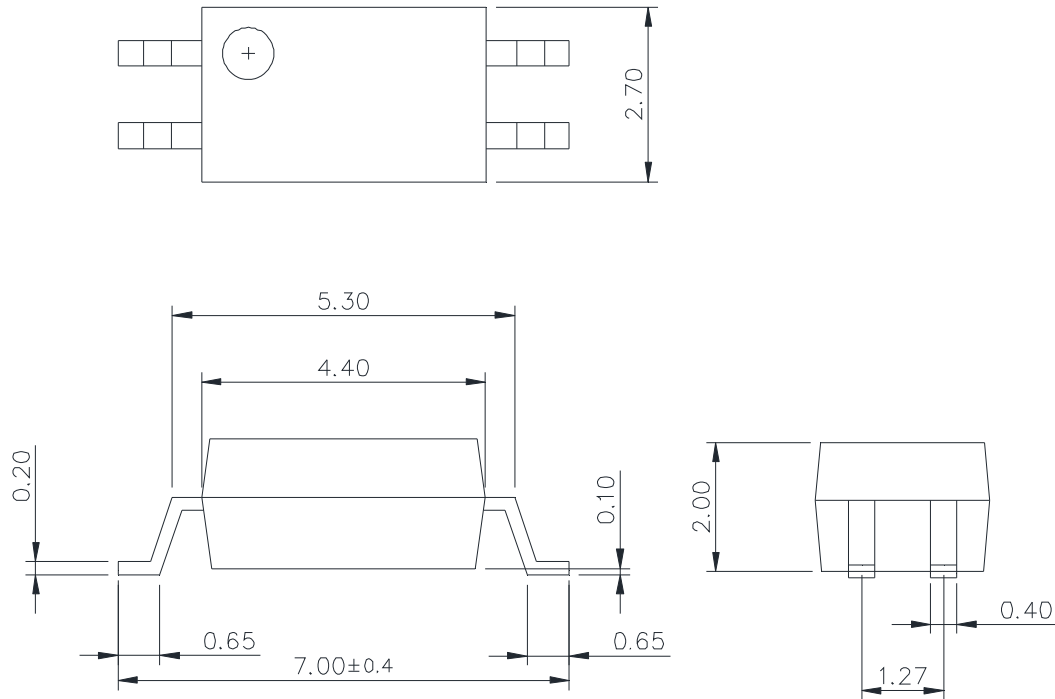

TOLERANCE : ±0.2mm

● **Device Marking**



Notes:

2801

YWW

Y: Year code / WW: Week code

● Absolute Maximum Ratings

(Ta=25°C)

Parameter		Symbol	Rating	Unit
Input	Forward current	I_F	50	mA
	Peak forward current(*1)	I_{FP}	1	A
	Reverse voltage	V_R	6	V
	Power dissipation	P_D	60	mW
	Power dissipation derating	$P_D/^\circ C$	0.6	mW/°C
Output	Collector-Emitter voltage	V_{CEO}	80	V
	Emitter-Collector voltage	V_{ECO}	6	V
	Collector current	I_C	50	mA
	Collector power dissipation	P_C	160	mW
	Collector power dissipation derating	$P_C/^\circ C$	1.2	mW/°C
Isolation voltage 1 minute(*2)		Viso	3750	Vrms
Operating temperature		Topr	-55 to +115	°C
Storage temperature		Tstg	-55 to +125	°C

*1 PW=100μs,Duty Cycle=1%.

*2 AC voltage for 1minute at T =25°C ,RH=60% between input and output.

● Electro-optical Characteristics

(Ta=25°C)

Parameter		Symbol	Conditions	Min.	Typ.	Max.	Unit
Input	Forward voltage	V_F	$I_F=5mA$	-	1.1	1.4	V
	Reverse current	I_R	$V_R=5V$	-	-	5	μA
	Terminal capacitance	C_t	$V=0, f=1MHz$	-	60	-	pF
Output	Collector dark current	I_{CEO}	$V_{CE}=50V, I_F=0mA$	-	-	100	nA
Transfer characteristics	Current transfer ratio	CTR	$I_F=1mA, V_{CE}=5V$	100	-	600	%
	Collector-Emitter saturation voltage	$V_{CE(sat)}$	$I_F=10mA, I_C=2mA$	-	0.1	0.2	V
	Isolation resistance	Riso	DC500V	5×10^{10}	10^{11}	-	Ω
	Floating capacitance	C_f	$V=0, f=1MHz$	-	0.4	-	pF
	Response time (Rise) (*3)	tr	$V_{ce}=5V, I_C=2mA, R_L=100\Omega$	-	4	18	μs
	Response time (Fall) (*3)	tf		-	3	18	μs

*3 Test Circuit for Switching Time

Classification table of current transfer ratio is shown below.

CTR Rank.	CTR (%)
KPS28010TA	100 TO 600
KPS28010TB	200 TO 500
KPS28010TC	160 TO 400
KPS28010TD	120 TO 300
KPS28010TE	100 TO 200

Fig.1 Current Transfer Ratio vs. Forward Current

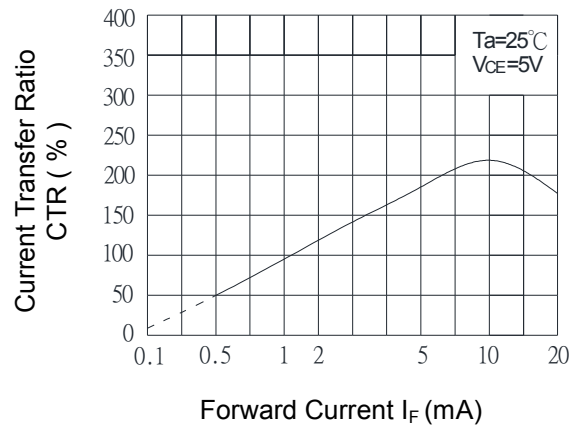

Fig.2 Collector Power Dissipation vs. Ambient Temperature

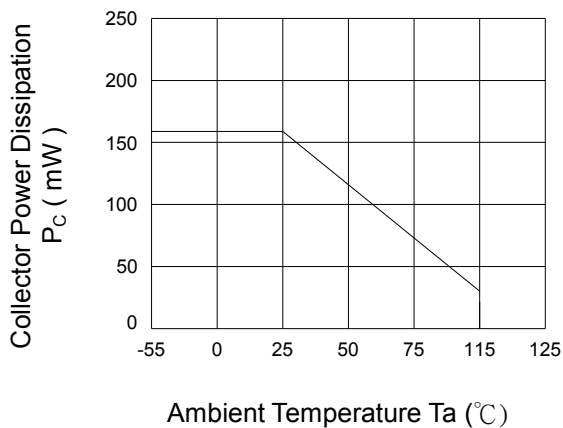

Fig.3 Collector Dark Current vs. Ambient Temperature

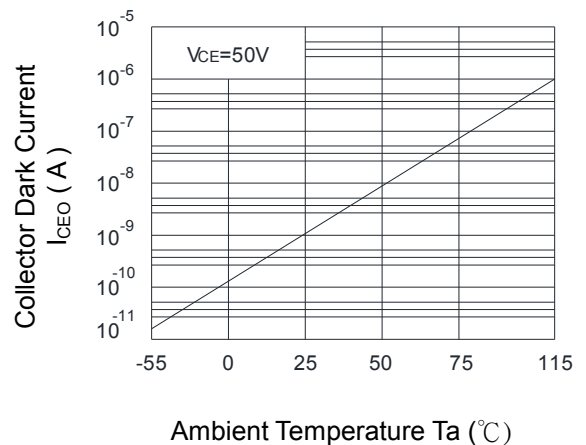

Fig.4 Forward Current vs. Ambient Temperature

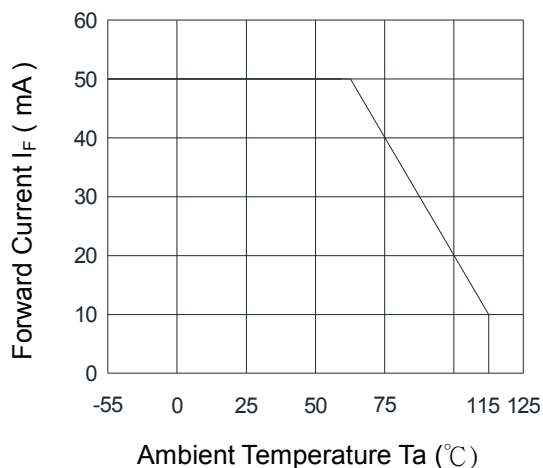

Fig.5 Forward Current vs. Forward Voltage

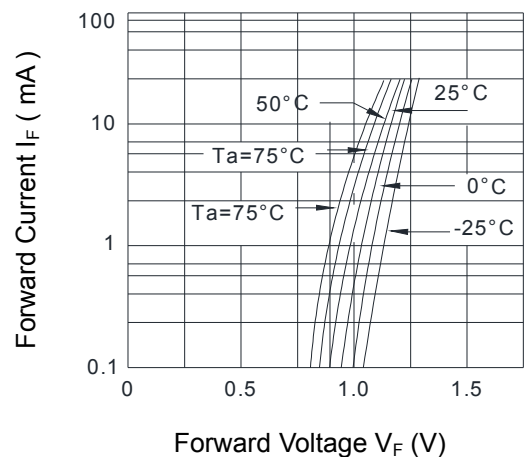

Fig.6 Collector Current vs. Collector-Emitter Voltage

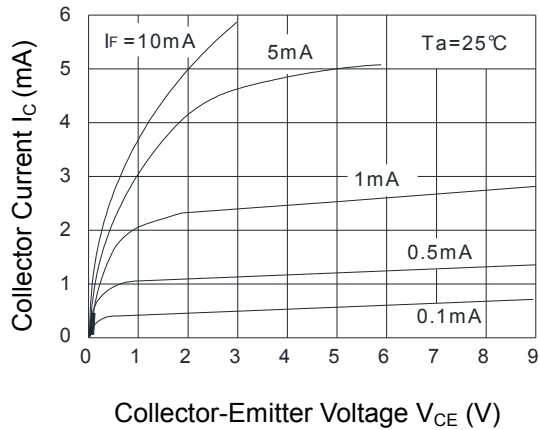

Fig.7 Relative Current Transfer Ratio vs. Ambient Temperature

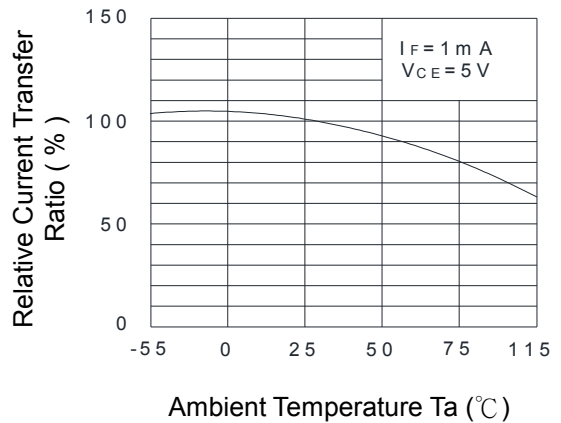

Fig.8 Collector-Emitter Saturation Voltage vs. Ambient Temperature

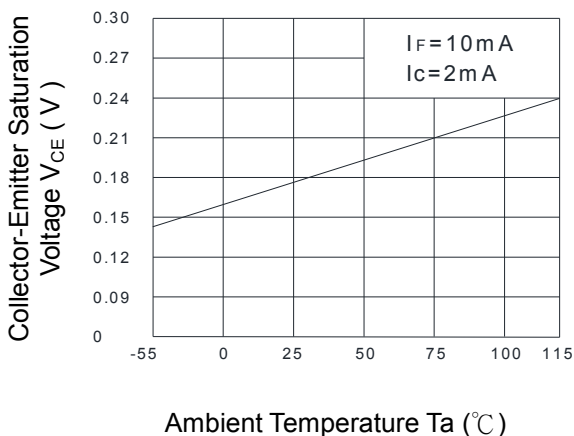

Fig.9 Collector-Emitter Saturation Voltage vs. Forward Current

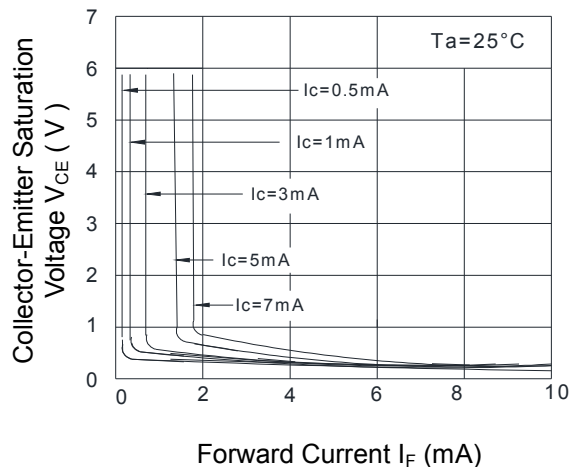

Fig.10 Response Time (Rise) vs. Load Resistance

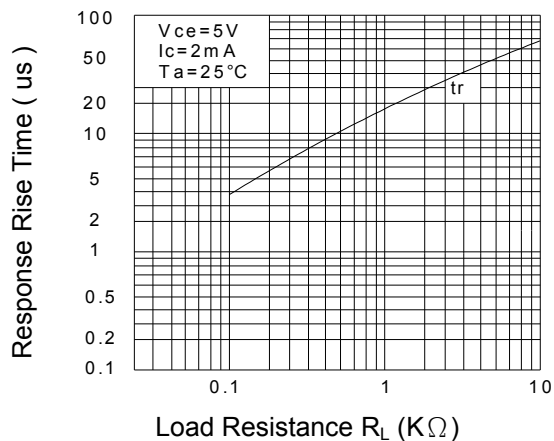
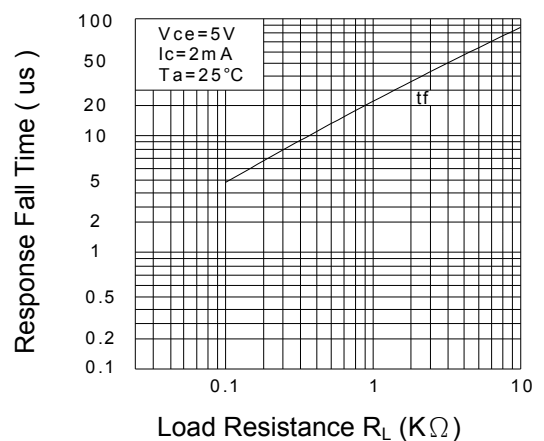
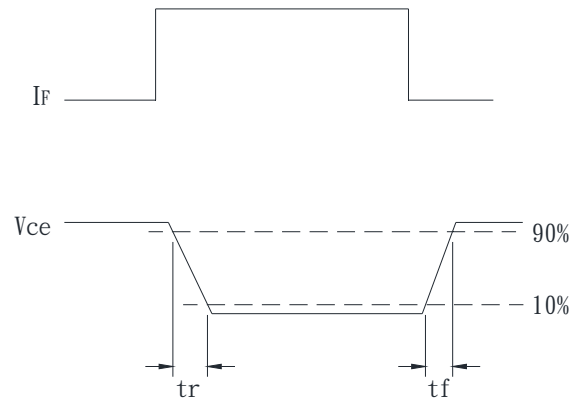
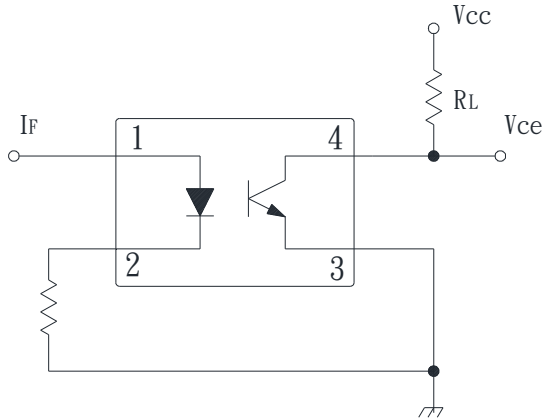

Fig.11 Response Time (Fall) vs. Load Resistance



● Test Circuit for Response Time



● Recommended Soldering Conditions

(a) Infrared reflow soldering :

- Peak reflow soldering : 260°C or below (package surface temperature)
- Time of peak reflow temperature : 10 sec
- Time of temperature higher than 230°C : 30-60 sec
- Time to preheat temperature from 180~190°C : 60-120 sec
- Time(s) of reflow : Two
- Flux : Rosin flux containing small amount of chlorine (The flux with a maximum chlorine content of 0.2 Wt% is recommended.)

Recommended Temperature Profile of Infrared Reflow

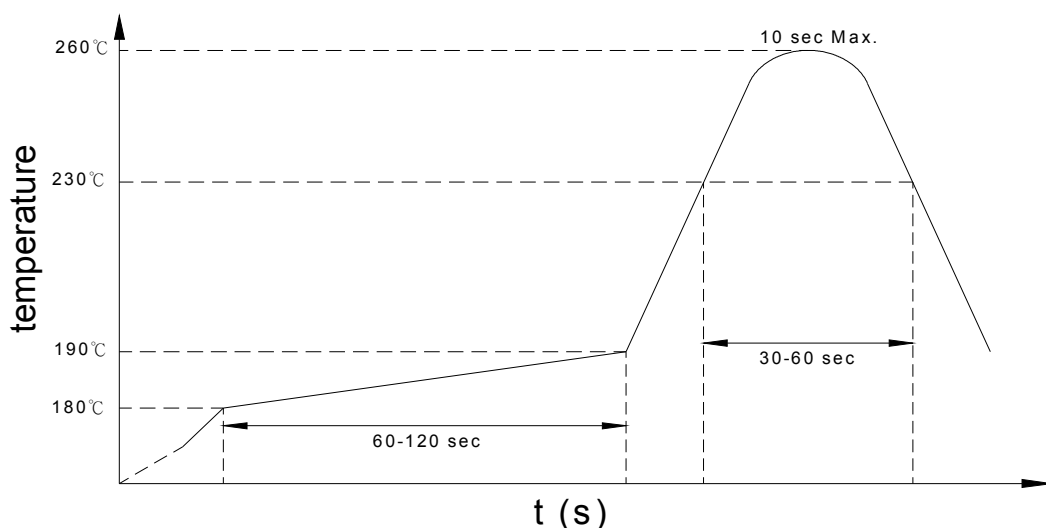

(b) Wave soldering :

- Temperature : 260°C or below (molten solder temperature)
- Time : 10 seconds or less
- Preheating conditions : 120°C or below (package surface temperature)
- Time(s) of reflow : One
- Flux : Rosin flux containing small amount of chlorine (The flux with a maximum chlorine content of 0.2 Wt% is recommended.)

(c) Cautions :

- Fluxes : Avoid removing the residual flux with freon-based and chlorine-based cleaning solvent.
- Avoid shorting between portion of frame and leads.

● **Numbering System**

KPS28010T Y (Z)

Notes:

KPS28010T = Part No.

Y = CTR rank option (A ~ E)

Z = Tape and reel option (TLD、TRU)

Option	Description	Packing quantity
TLD	TLD tape & reel option	3000 units per reel
TRU	TRU tape & reel option	3000 units per reel

● **Recommended Pad Layout for Surface Mount Lead Form**

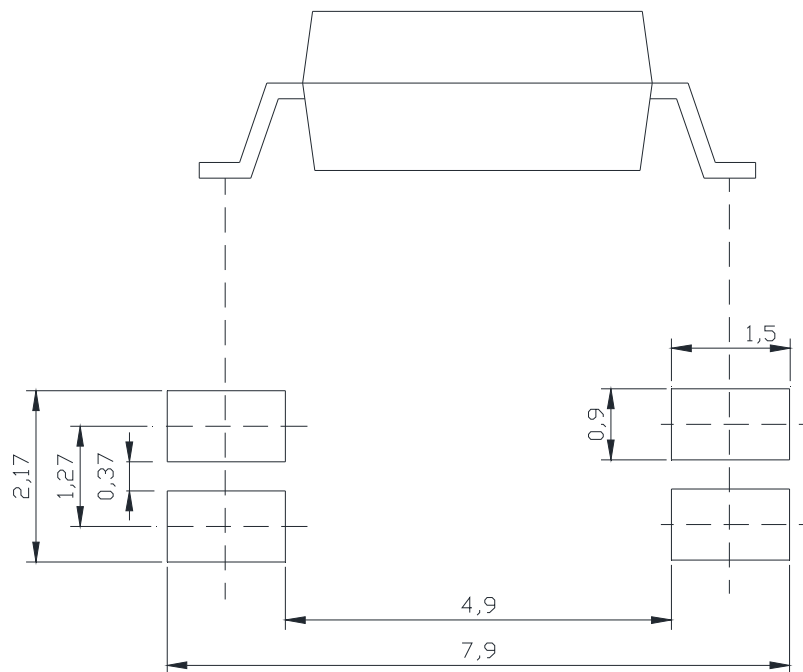

Unit :mm

● 4-pin SSOP Carrier Tape & Reel

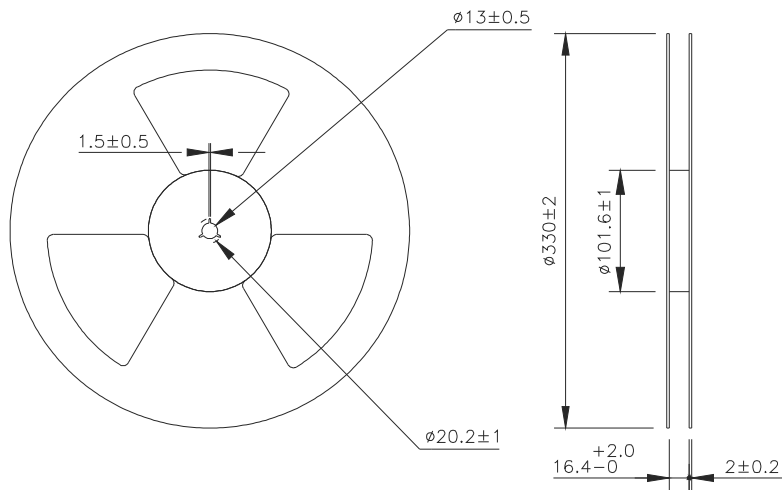
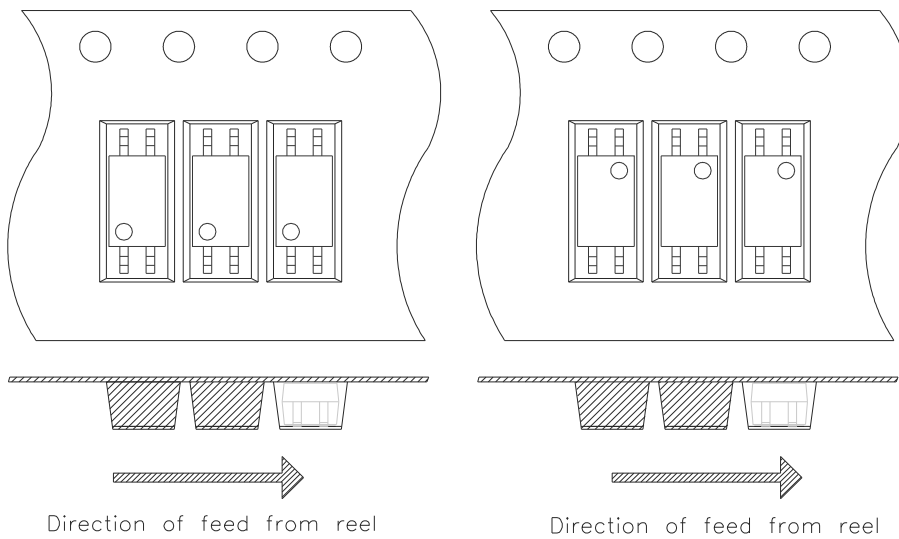
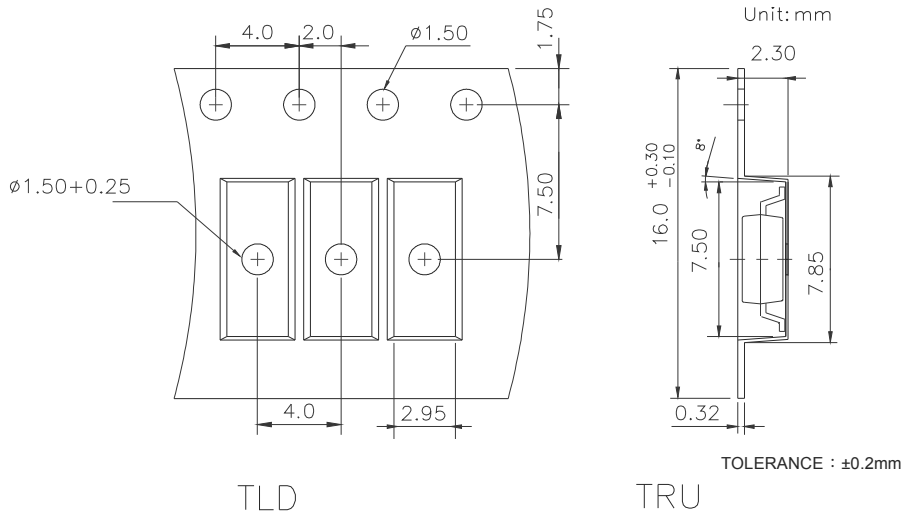



KPS28010T Series

4PIN SSOP LOW INPUT CURRENT PHOTOCOUPLER

● Application Notice

The content of datasheet is the guidance for product use only. cosmo takes no responsibility to the accuracy of the information provided here. For continuously improving all of products, including quality, reliability, function...etc., cosmo reserves the right to change the specification, characteristics, data, materials, and structure of products without notice. Please contact with cosmo to obtain the latest specification.

It would be required to comply with the absolute maximum ratings listed in the specification. cosmo has no liability and responsibility to the damage caused by improper use of the products.

cosmo products are intended to be designed for use in general electronics application list below:

- a. Personal computer
- b. OA machine
- c. Audio / Video
- d. Instrumentation
- e. Electrical application
- f. Measurement equipment
- g. Consumer electronics
- h. Telecommunication

cosmo devices shall not be used or related with equipment requiring higher level of quality / reliability, or malfunction, or failure which may cause loss of human life, bodily injury, includes, without limitation:

- a. Medical and other life supporting equipments
- b. Space application
- c. Telecommunication equipment (trunk lines)
- d. Nuclear power control
- e. Equipment used for automotive vehicles, trains, ships...etc.

This publication is the property of cosmo. No part of this publication may be reproduced or copied in any form or any means electronically or mechanically for any purpose, in whole or in part without any written permission expressed from cosmo.