

# 1

## PRODUCT OVERVIEW

### OVERVIEW

The KS57C2302/C2304 single-chip CMOS microcontroller has been designed for high performance using Samsung's newest 4-bit CPU core, SAM47 (Samsung Arrangeable Microcontrollers).

With features such as, LCD direct drive capability, 8-bit timer/counter, and watch timer, the KS57C2302/C2304 offers an excellent design solution for a wide variety of applications that require LCD functions.

Up to 16 pins of the 64-pin QFP package, it can be dedicated to I/O. Four vectored interrupts provide fast response to internal and external events. In addition, the KS57C2302/C2304 's advanced CMOS technology provides for low power consumption and a wide operating voltage range.

### OTP

The KS57C2302/C2304 microcontroller is also available in OTP (One Time Programmable) version, KS57P2304 . The KS57P2304 microcontroller has an on-chip 4-Kbyte one-time-programmable EPROM instead of masked ROM. The KS57P2304 is comparable to KS57C2302/C2304, both in function and in pin configuration.

## FEATURES

### Memory

- 288 × 4-bit RAM
- 2048 × 8-bit ROM (KS57C2302)
- 4096 × 8-bit ROM (KS57C2304)

### I/O Pins

- Input only: 4 pins
- I/O: 12 pins
- Output: 8 pins sharing with segment driver outputs

### LCD Controller/Driver

- Maximum 16-digit LCD direct drive capability
- 32 segment, 4 common pins
- Display modes: Static, 1/2 duty (1/2 bias)  
1/3 duty (1/2 or 1/3 bias), 1/4 duty (1/3 bias)

### 8-Bit Basic Timer

- Programmable interval timer
- Watchdog timer

### 8-Bit Timer/Counter

- Programmable 8-bit timer
- External event counter
- Arbitrary clock frequency output

### Watch Timer

- Real-time and interval time measurement
- Four frequency outputs to BUZ pin
- Clock source generation for LCD

### Bit Sequential Carrier

- Support 16-bit serial data transfer in arbitrary format

### Interrupts

- Two internal vectored interrupts
- Two external vectored interrupts
- Two quasi-interrupts

### Memory-Mapped I/O Structure

- Data memory bank 15

### Two Power-Down Modes

- Idle mode (only CPU clock stops)
- Stop mode (main or sub system oscillation stops)

### Oscillation Sources

- Crystal, ceramic, or RC for main system clock
- Crystal or external oscillator for subsystem clock
- Main system clock frequency: 4.19 MHz (typical)
- Subsystem clock frequency: 32.768 kHz
- CPU clock divider circuit (by 4, 8, or 64)

### Instruction Execution Times

- 0.95, 1.91, 15.3  $\mu$ s at 4.19 MHz (main)
- 122  $\mu$ s at 32.768 kHz (subsystem)

### Operating Temperature

- -40 °C to 85 °C

### Operating Voltage Range

- 2.0 V to 5.5 V at 4.19 MHz
- 1.8 V to 5.5 V at 3 MHz

### Package Type

- 64-pin QFP

## BLOCK DIAGRAM

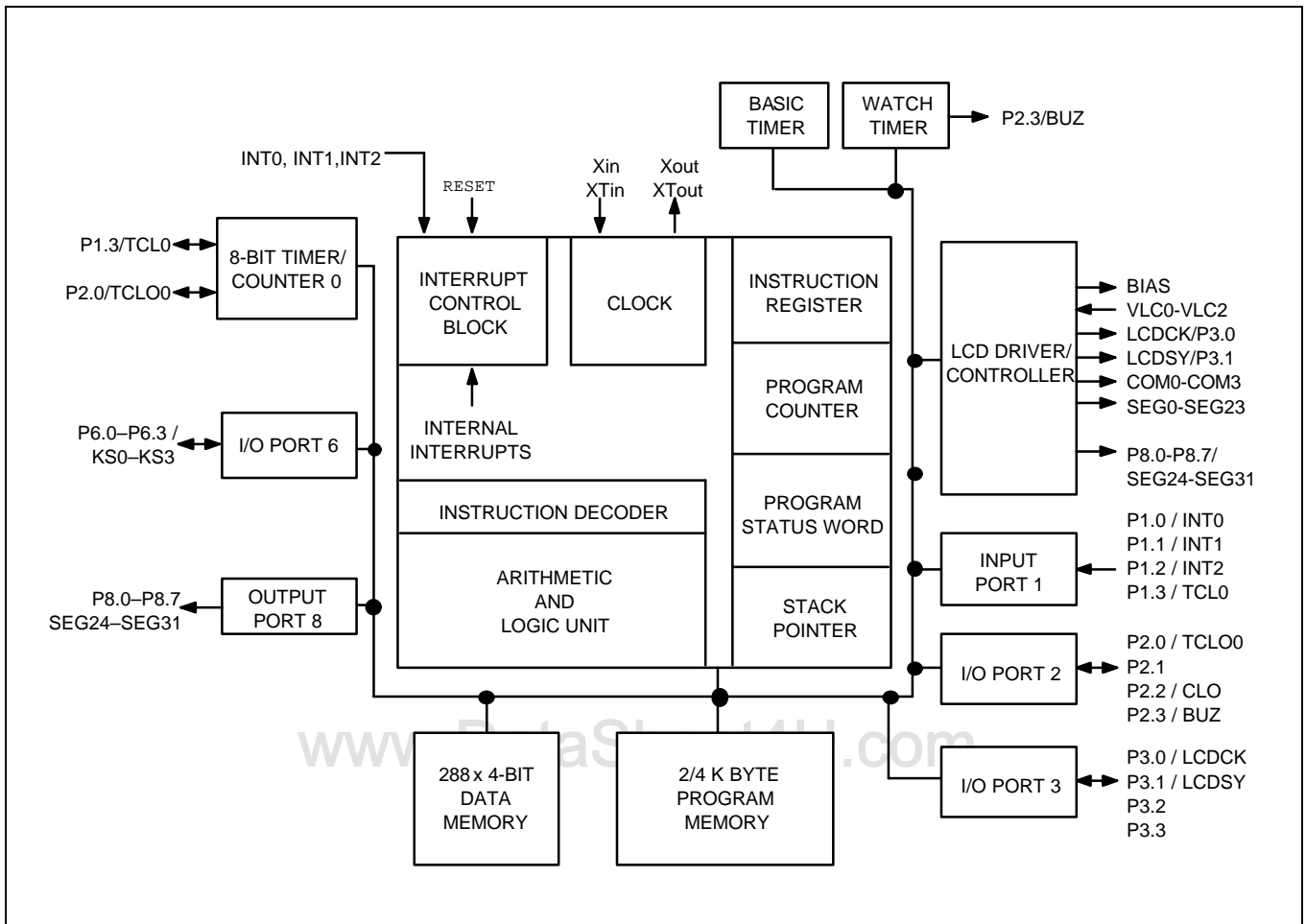

Figure 1-1. KS57C2302/C2304 Simplified Block Diagram

PIN ASSIGNMENTS

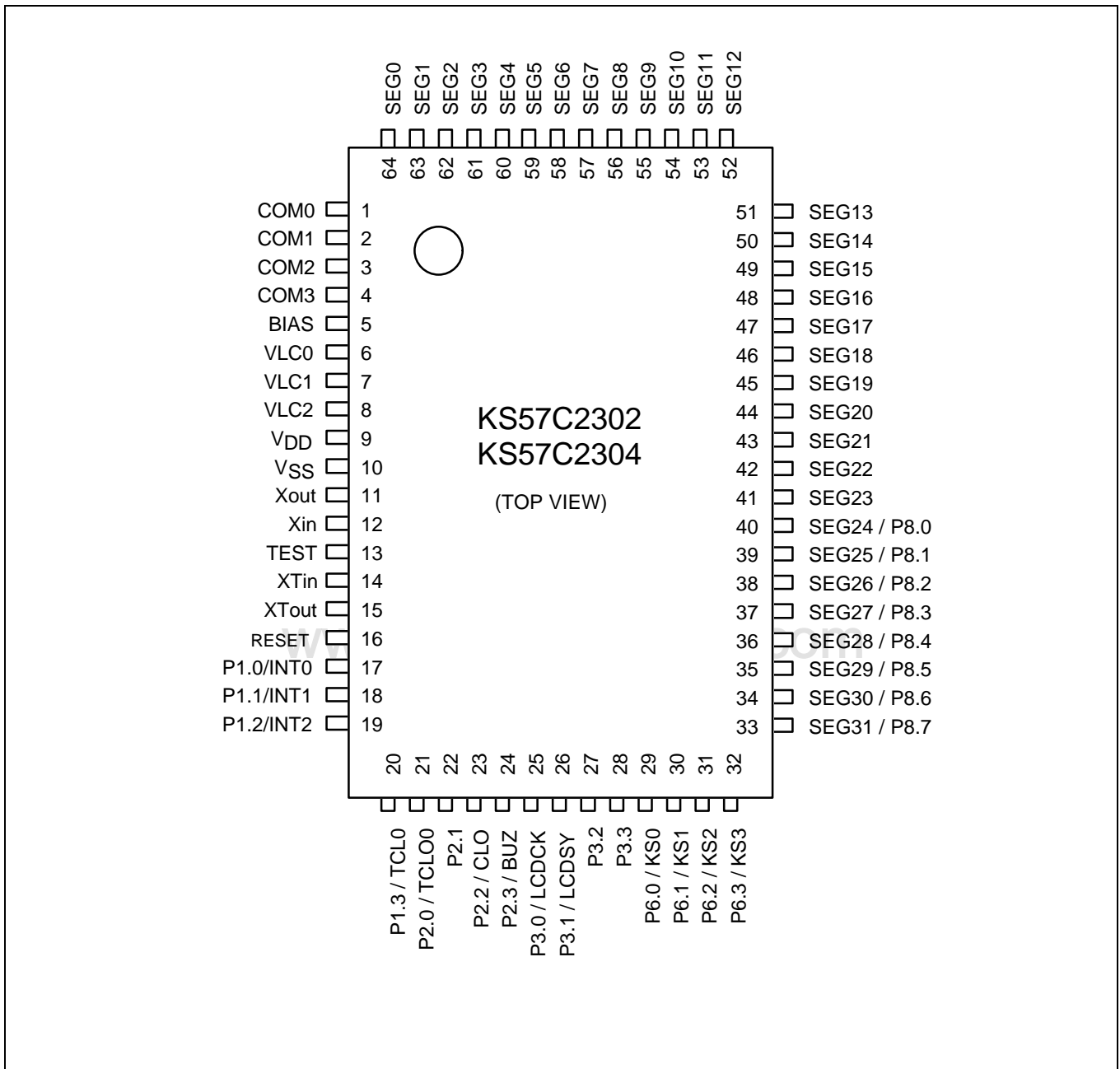

Figure 1-2. KS57C2302/C2304 64-QFP Pin Assignment

## PIN DESCRIPTIONS

Table 1-1. KS57C2302/C2304 Pin Descriptions

Pin Name	Pin Type	Description	Number	Share Pin	Reset Value	Circuit Type
P1.0 P1.1 P1.2 P1.3	I	4-bit input port. 1-bit or 4-bit read and test is possible. 4-bit pull-up resistors are software assignable.	17 18 19 20	INT0 INT1 INT2 TCL0	Input	A-4
P2.0 P2.1 P2.2 P2.3	I/O	4-bit I/O port. 1-bit and 4-bit read/write and test is possible. 4-bit pull-up resistors are software assignable.	21 22 23 24	TCLO0 – CLO BUZ	Input	D
P3.0 P3.1 P3.2 P3.3	I/O	4-bit I/O port. 1-bit and 4-bit read/write and test is possible. Each individual pin can be specified as input or output. 4-bit pull-up resistors are software assignable.	25 26 27 28	LCDCK LCDSY	Input	D
P6.0–P6.3	I/O	4-bit I/O ports. Pins are individually software configurable as input or output. 1-bit and 4-bit read/write and test is possible. 4-bit pull-up resistors are software assignable.	29–32	KS0–KS3	Input	D
P8.0–P8.7	O	Output port for 1-bit data (for use as CMOS driver only)	40–33	SEG24– SEG31	Output	H-1
SEG0–SEG23	O	LCD segment signal output	64–41	–	Output	H
SEG24–SEG31	O	LCD segment signal output	40–33	P8.0–P8.7	Output	H-1
COM0–COM3	O	LCD common signal output	1–4	–	Output	H
$V_{LC0}$ – $V_{LC2}$	–	LCD power supply. Built-in voltage dividing resistors	6–8	–	–	–
BIAS	–	LCD power control	5	–	–	–
LCDCK	I/O	LCD clock output for display expansion	25	P3.0	Input	D

Table 1-1. KS57P2304 Pin Descriptions (Continued)

Pin Name	Pin Type	Description	Number	Share Pin	Reset Value	Circuit Type
LCDSY	I/O	LCD synchronization clock output for LCD display expansion	26	P3.1	Input	D
TCL0	I	External clock input for timer/counter 0	20	P1.3	Input	A-4
TCLO0	I/O	Timer/counter 0 clock output	21	P2.0	Input	D
INT0 INT1	I	External interrupt. The triggering edge for INT0 and INT1 is selectable. Only INT0 is synchronized with the system clock.	17 18	P1.0 P1.1	Input	A-4
INT2	I	Quasi-interrupt with detection of rising edge signals.	19	P1.2	Input	A-4
KS0–KS3	I/O	Quasi-interrupt input with falling edge detection.	29–32	P6.0–P6.3	Input	D
CLO	I/O	CPU clock output	23	P2.2	Input	D
BUZ	I/O	2, 4, 8 or 16 kHz frequency output for buzzer sound with 4.19 MHz main system clock or 32.768 kHz subsystem clock.	24	P2.3	Input	D
X <sub>IN</sub> , X <sub>OUT</sub>	–	Crystal, ceramic or RC oscillator pins for main system clock. (For external clock input, use X <sub>IN</sub> and input X <sub>IN</sub> 's reverse phase to X <sub>OUT</sub> )	12,11	–	–	–
XT <sub>IN</sub> , XT <sub>OUT</sub>	–	Crystal oscillator pins for subsystem clock. (For external clock input, use XT <sub>IN</sub> and input XT <sub>IN</sub> 's reverse phase to XT <sub>OUT</sub> )	14,15	–	–	–
V <sub>DD</sub>	–	Main power supply	9	–	–	–
V <sub>SS</sub>	–	Ground	10	–	–	–
RESET	–	Reset signal	16	–	Input	B
TEST	–	Test signal input (must be connected to V <sub>SS</sub> )	13	–	–	–

**NOTE:** Pull-up resistors for all I/O ports automatically disabled if they are configured to output mode.

PIN CIRCUIT DIAGRAMS

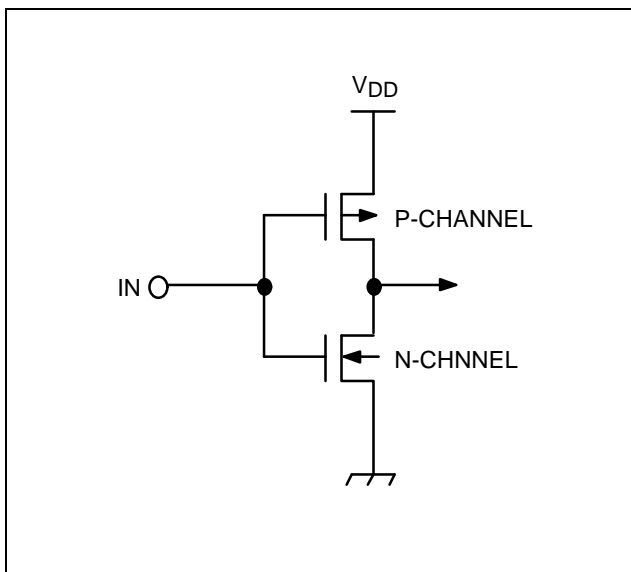

Figure 1-3. Pin Circuit Type A

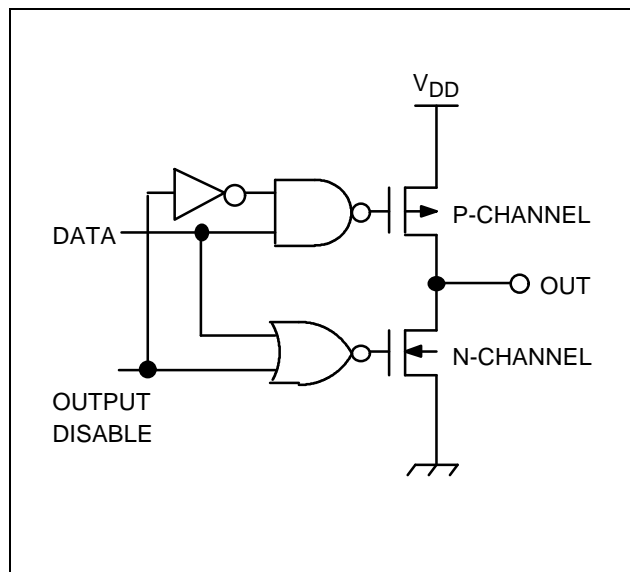

Figure 1-5. Pin Circuit Type C

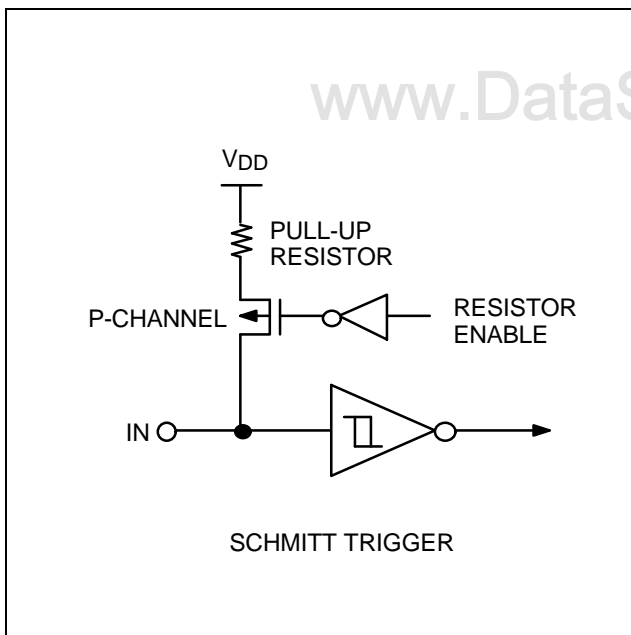

Figure 1-4. Pin Circuit Type A-4 (P1)

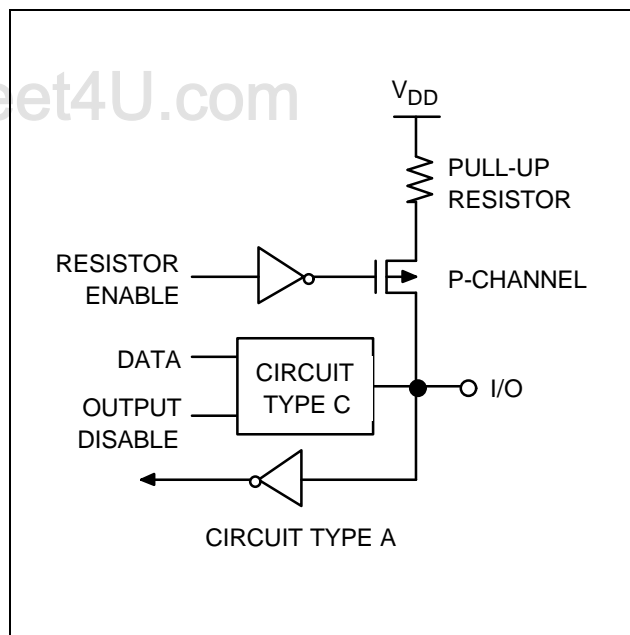

Figure 1-6. Pin Circuit Type D (P2, P3, and P6)

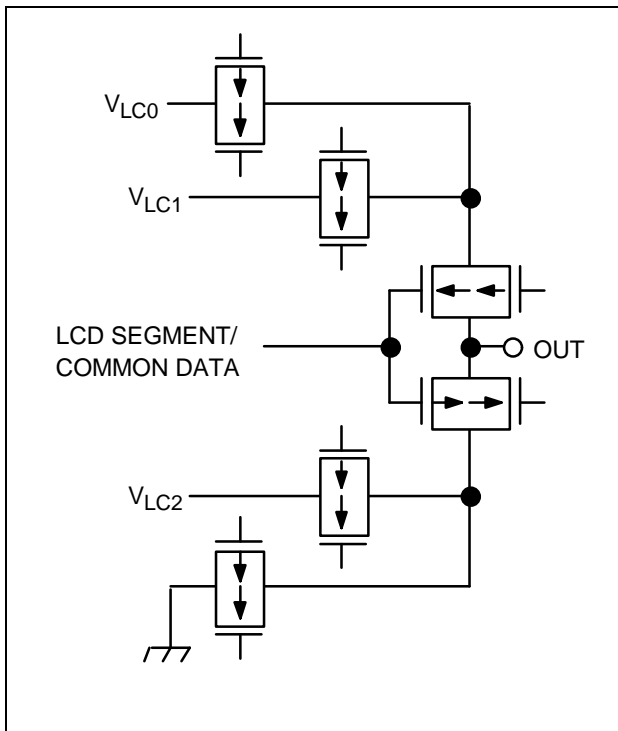

Figure 1-7. Pin Circuit Type H (SEG/COM)

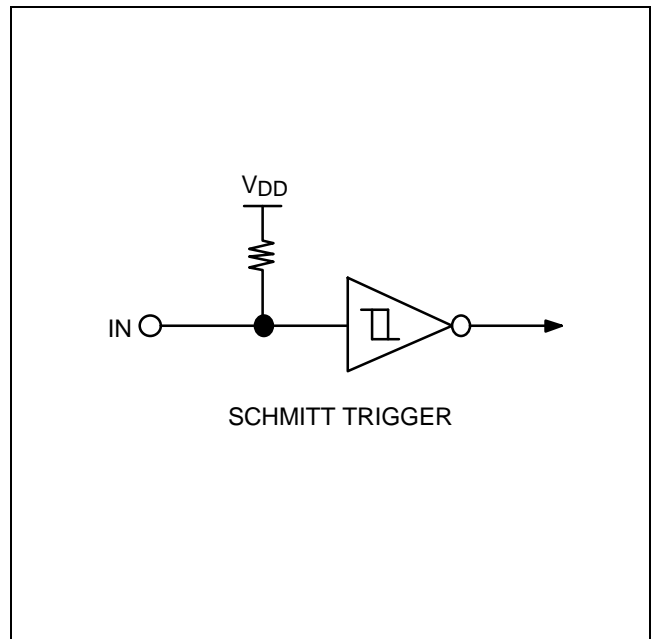

Figure 1-9. Pin Circuit Type B (RESET)

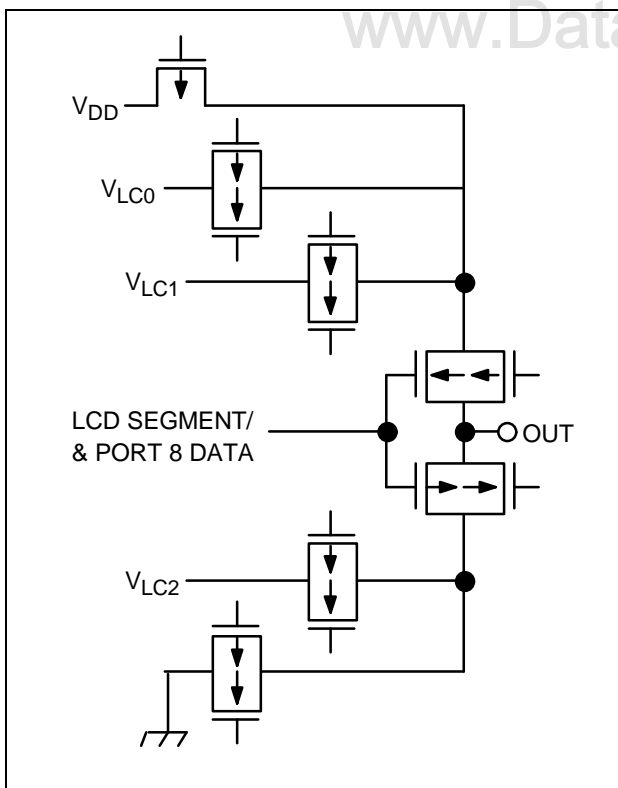

Figure 1-8. Pin Circuit Type H-1 (P8)



# 2 ADDRESS SPACES

## PROGRAM MEMORY (ROM)

### OVERVIEW

ROM maps for KS57C2302/C2304 devices are mask programmable at the factory. KS57C2302 has  $2K \times 8$ -bit program memory and KS57C2304 has  $4K \times 8$ -bit program memory, aside from the differences in the ROM size the two products are identical in other features. In its standard configuration, the device's  $4,096 \times 8$ -bit program memory has four areas that are directly addressable by the program counter (PC):

- 12-byte area for vector addresses
- 96-byte instruction reference area
- 20-byte general-purpose area
- 1920-byte general-purpose area (KS57C2302)  
3968-byte general-purpose area (KS57C2304)

### General-Purpose Program Memory

Two program memory areas are allocated for general-purpose use: One area is 20 bytes in size and the other is 1,920 bytes (KS57C2302) or 3,968 bytes (KS57C2304).

### Vector Addresses

A 12-byte vector address area is used to store the vector addresses required to execute system resets and interrupts. Start addresses for interrupt service routines are stored in this area, along with the values of the enable memory bank (EMB) and enable register bank (ERB) flags that are used to set their initial value for the corresponding service routines. The 12-byte area can be used alternately as general-purpose ROM.

### REF Instructions

Locations 0020H–007FH are used as a reference area (look-up table) for 1-byte REF instructions. The REF instruction reduces the byte size of instruction operands. REF can reference one 2-byte instruction, two 1-byte instructions, and 3-byte instructions which are stored in the look-up table. Unused look-up table addresses can be used as general-purpose ROM.

**Table 2-1. Program Memory Address Ranges**

ROM Area Function	Address Ranges	Area Size (in Bytes)
Vector address area	0000H–000BH	12
General-purpose program memory	000CH–001FH	20
REF instruction look-up table area	0020H–007FH	96
General-purpose program memory	0080H–7FFFH (KS57C2302) 0080H–0FFFH (KS57C2304)	1920 (KS57C2302) 3968 (KS57C2304)

## GENERAL-PURPOSE MEMORY AREAS

The 20-byte area at ROM locations 000CH–001FH and the 3,968-byte area at ROM locations 0080H–0FFFH are used as general-purpose program memory. Unused locations in the vector address area and REF instruction look-up table areas can be used as general-purpose program memory. However, care must be taken not to overwrite live data when writing programs that use special-purpose areas of the ROM.

## VECTOR ADDRESS AREA

The 12-byte vector address area of the ROM is used to store the vector addresses for executing system resets and interrupts. The starting addresses of interrupt service routines are stored in this area, along with the enable memory bank (EMB) and enable register bank (ERB) flag values that are needed to initialize the service routines. 12-byte vector addresses are organized as follows:

EMB	ERB	0	0	PC11	PC10	PC9	PC8
PC7	PC6	PC5	PC4	PC3	PC2	PC1	PC0

To set up the vector address area for specific programs, use the instruction VENTn. The programming tips on the next page explain how to do this.

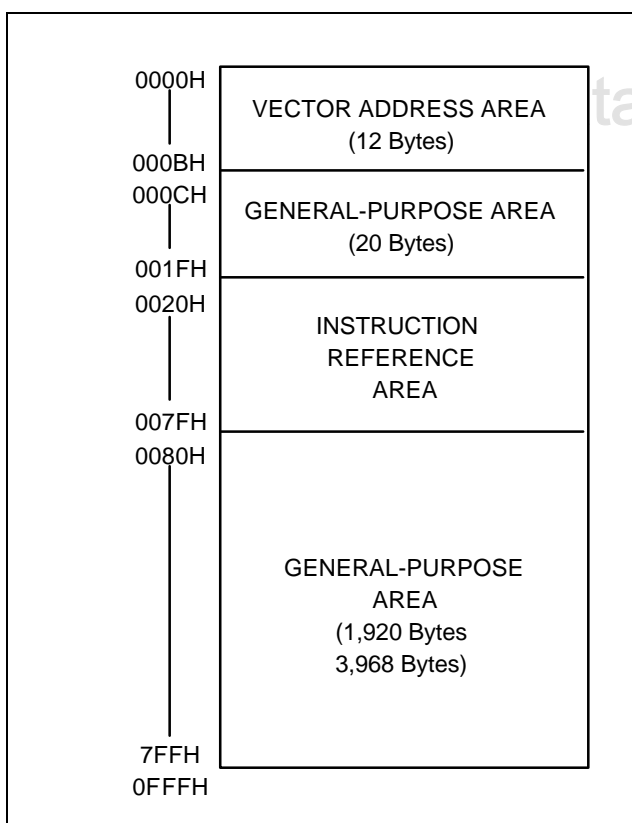

Figure 2-1. ROM Address Structure

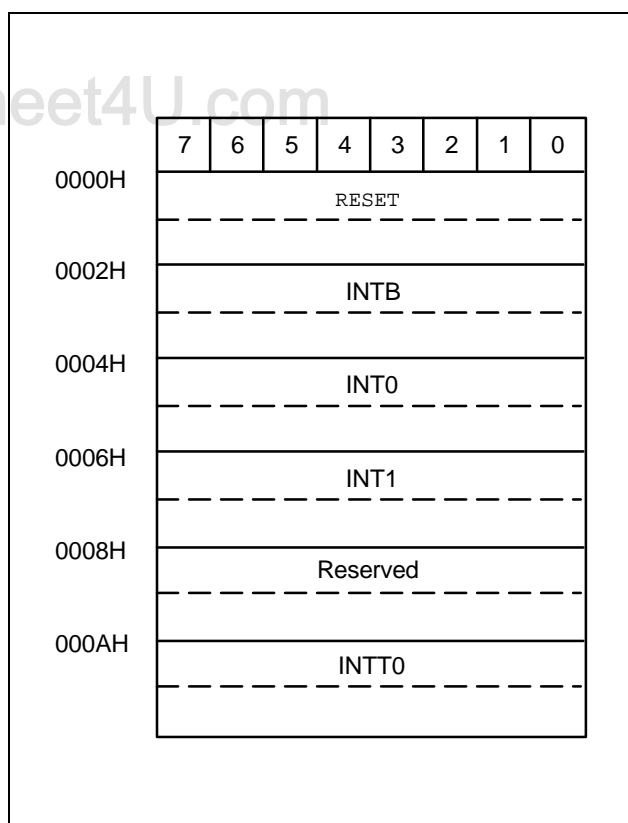

Figure 2-2. Vector Address Structure

### PROGRAMMING TIP — Defining Vectored Interrupts

The following examples show you several ways you can define the vectored interrupt and instruction reference areas in program memory:

1. When all vector interrupts are used:

```

ORG      0000H

VENT0    1,0,RESET          ; EMB ← 1, ERB ← 0; Jump to RESET address
VENT1    0,0,INTB           ; EMB ← 0, ERB ← 0; Jump to INTB address
VENT2    0,0,INT0           ; EMB ← 0, ERB ← 0; Jump to INT0 address
VENT3    0,0,INT1           ; EMB ← 0, ERB ← 0; Jump to INT1 address

```

```

ORG      000AH

VENT5    0,0,INTT0          ; EMB ← 0, ERB ← 0; Jump to INTT0 address

```

2. When a specific vectored interrupt such as INT0, and INTT0 is not used, the unused vector interrupt locations must be skipped with the assembly instruction ORG so that jumps will address the correct locations:

```

ORG      0000H

VENT0    1,0,RESET          ; EMB ← 1, ERB ← 0; Jump to RESET address
VENT1    0,0,INTB           ; EMB ← 0, ERB ← 0; Jump to INTB address
ORG      0006H              ; INT0 interrupt not used
VENT3    0,0,INT1           ; EMB ← 0, ERB ← 0; Jump to INT1 address

```

```

ORG      0010H

```

3. If an INT0 interrupt is not used and if its corresponding vector interrupt area is not fully utilized, or if it is not written by a ORG instruction as in Example 2, a CPU malfunction will occur:

```

ORG      0000H

VENT0    1,0,RESET          ; EMB ← 1, ERB ← 0; Jump to RESET address
VENT1    0,0,INTB           ; EMB ← 0, ERB ← 0; Jump to INTB address
VENT3    0,0,INT1           ; EMB ← 0, ERB ← 0; Jump to INT0 address
VENT5    0,0,INTT0          ; EMB ← 0, ERB ← 0; Jump to INT1 address

```

```

ORG      0010H

```

General-purpose ROM area

In this example, when an INT1 interrupt is generated, the corresponding vector area is not VENT3 INT1, but VENT5 INTT0. This causes an INT1 interrupt to jump incorrectly to the INTT0 address and causes a CPU malfunction to occur.

## INSTRUCTION REFERENCE AREA

Using 1-byte REF instructions, you can easily reference instructions with larger byte sizes that are stored in addresses 0020H–007FH of program memory. This 96-byte area is called the REF instruction reference area, or look-up table. Locations in the REF look-up table may contain two one-byte instructions, a single two-byte instruction, or three-byte instruction such as a JP (jump) or CALL. The starting address of the instruction you are referencing must always be an even number. To reference a JP or CALL instruction, it must be written to the reference area in a two-byte format: for JP, this format is TJP; for CALL, it is TCALL.

By using REF instructions to execute instructions larger than one byte, you can improve program execution time considerably by reducing the number of program steps. In summary, there are three ways you can use the REF instruction:

- Using the 1-byte REF instruction to execute one 2-byte or two 1-byte instructions,
- Branching to any location by referencing a branch instruction stored in the look-up table,
- Calling subroutines at any location by referencing a call instruction stored in the look-up table.

### PROGRAMMING TIP — Using the REF Look-Up Table

Here is one example of how to use the REF instruction look-up table:

	ORG	0020H	
JMAIN	TJP	MAIN	; 0, MAIN
KEYCK	BTSF	KEYFG	; 1, KEYFG CHECK
WATCH	TCALL	CLOCK	; 2, CALL CLOCK
INCHL	LD	@HL,A	; 3, (HL) ← A
	INCS	HL	
	•		
	•		
	•		
ABC	LD	EA,#00H	; 47, EA ← #00H
	ORG	0080H	
MAIN	NOP		
	NOP		
	•		
	•		
	•		
	REF	KEYCK	; BTSF KEYFG (1-byte instruction)
	REF	JMAIN	; KEYFG = 1, jump to MAIN (1-byte instruction)
	REF	WATCH	; KEYFG = 0, CALL CLOCK (1-byte instruction)
	REF	INCHL	; LD @HL,A
			; INCS HL
	REF	ABC	; LD EA,#00H (1-byte instruction)
	•		
	•		
	•		

## DATA MEMORY (RAM)

### OVERVIEW

In its standard configuration, the 288 x 4-bit data memory has three areas:

- 32 x 4-bit working register area in bank 0
- 224 x 4-bit general-purpose area in bank 0 which is also used as the stack area
- 32 x 4-bit area for LCD data in bank 1
- 128 x 4-bit area in bank 15 for memory-mapped I/O addresses

To make it easier to reference, the data memory area has three memory banks — bank 0, bank 1, and bank 15. The select memory bank instruction (SMB) is used to select the bank you want to select as working data memory. Data stored in RAM locations are 1-, 4-, and 8-bit addressable. One exception is the LCD data register area, which is 1-bit and 4-bit addressable only.

Initialization values for the data memory area are not defined by hardware and must therefore be initialized by program software following power reset. However, when RESET signal is generated in power-down mode, the data memory contents are held.

www.DataSheet4U.com

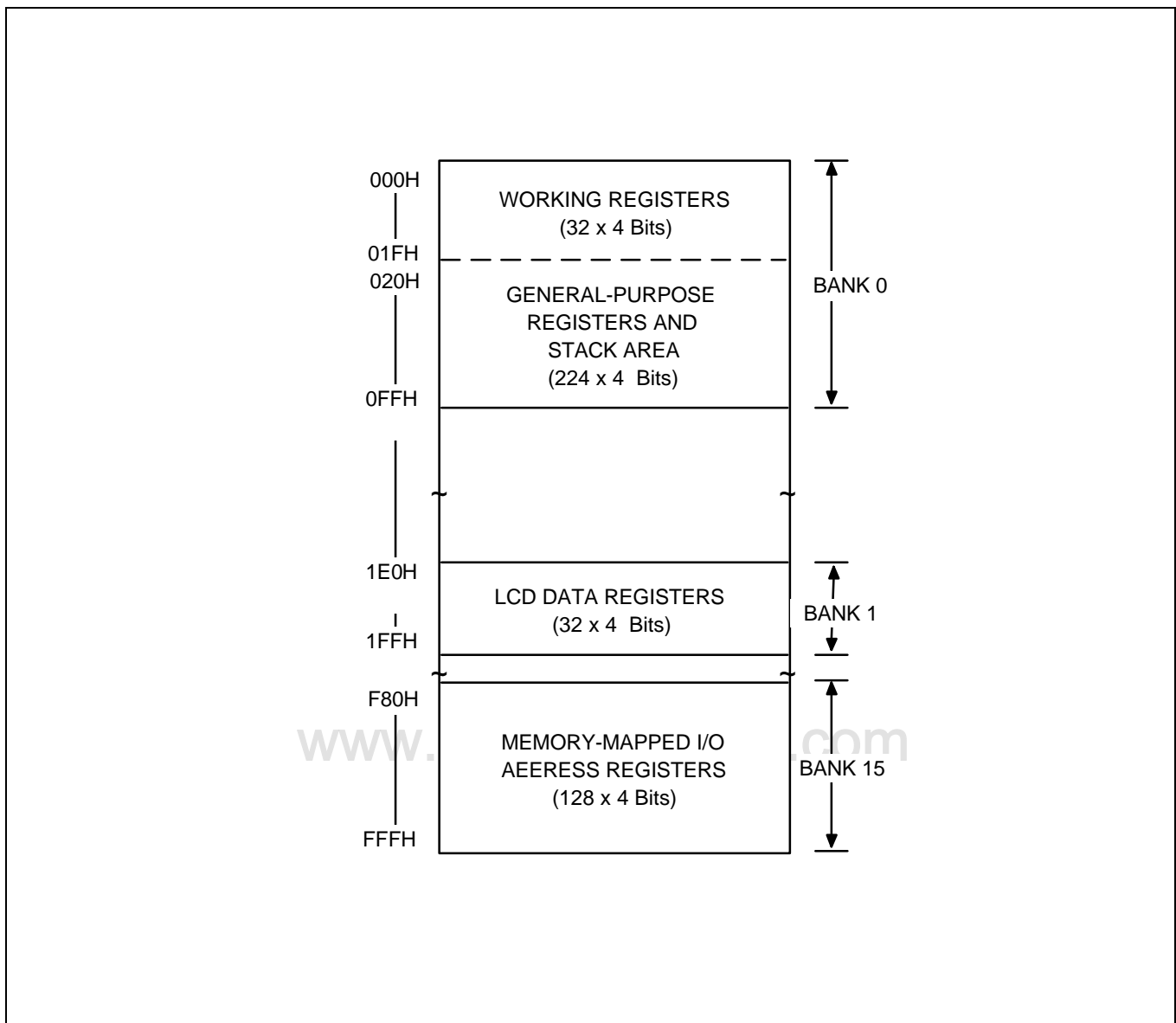

Figure 2-3. Data Memory (RAM) Map

### Memory Banks 0, 1, and 15

Bank 0	(000H–0FFH)	The lowest 32 nibbles of bank 0 (000H–01FH) are used as working registers; the next 224 nibbles (020H–0FFH) can be used both as stack area and as general-purpose data memory. Use the stack area for implementing subroutine calls and returns, and for interrupt processing.
Bank 1	(1E0H–1FFH)	32 nibbles of bank 1 are used as display registers or general purpose memory.
Bank 15	(F80H–FFFH)	The microcontroller uses bank 15 for memory-mapped peripheral I/O. Fixed RAM locations for each peripheral hardware address are mapped into this area.

### Data Memory Addressing Modes

The enable memory bank (EMB) flag controls the addressing mode for data memory banks 0, 1, or 15. When the EMB flag is logic zero, the addressable area is restricted to specific locations, depending on whether direct or indirect addressing is used. With direct addressing, you can access locations 000H–07FH of bank 0 and bank 15. With indirect addressing, only bank 0 (000H–0FFH) can be accessed. When the EMB flag is set to logic one, all three data memory banks can be accessed according to the current SMB value.

For 8-bit addressing, two 4-bit registers are addressed as a register pair. Also, when using 8-bit instructions to address RAM locations, remember to use the even-numbered register address as the instruction operand.

### Working Registers

The RAM working register area in data memory bank 0 is further divided into four *register* banks (bank 0, 1, 2, and 3). Each register bank has eight 4-bit registers and paired 4-bit registers are 8-bit addressable.

Register A is used as a 4-bit accumulator and register pair EA as an 8-bit extended accumulator. The carry flag bit can also be used as a 1-bit accumulator. Register pairs WX, WL, and HL are used as address pointers for indirect addressing. To limit the possibility of data corruption due to incorrect register addressing, it is advisable to use register bank 0 for the main program and banks 1, 2, and 3 for interrupt service routines.

### LCD Data Register Area

Bit values for LCD segment data are stored in data memory bank 1. Register locations in this area that are not used to store LCD data can be assigned to general-purpose use.

Table 2-2. Data Memory Organization and Addressing

Addresses	Register Areas	Bank	EMB Value	SMB Value
000H–01FH	Working registers	0	0, 1	0
020H–0FFH	Stack and general-purpose registers			
1E0H–1FFH	LCD Data registers	1	1	1
F80H–FFFH	I/O-mapped hardware registers	15	0, 1	15

 **PROGRAMMING TIP — Clearing Data Memory Banks 0 and 1**

Clear banks 0 and 1 of the data memory area:

```

RAMCLR   BITS   EMB
          SMB    1           ; RAM (1E0H–1FFH) clear
          LD    HL, #0E0H
          LD    A, #0H
RMCL1    LD    @HL, A
          INCS HL
          JR    RMCL1

          SMB    0           ; RAM (010H–0FFH) clear
RMCL0    LD    HL, #10H
          LD    @HL, A
          INCS HL
          JR    RMCL0

```



## WORKING REGISTERS

Working registers, mapped to RAM address 000H–01FH in data memory bank 0, are used to temporarily store intermediate results during program execution, as well as pointer values used for indirect addressing. Unused registers may be used as general-purpose memory. Working register data can be manipulated as 1-bit units, 4-bit units or, using paired registers, as 8-bit units.

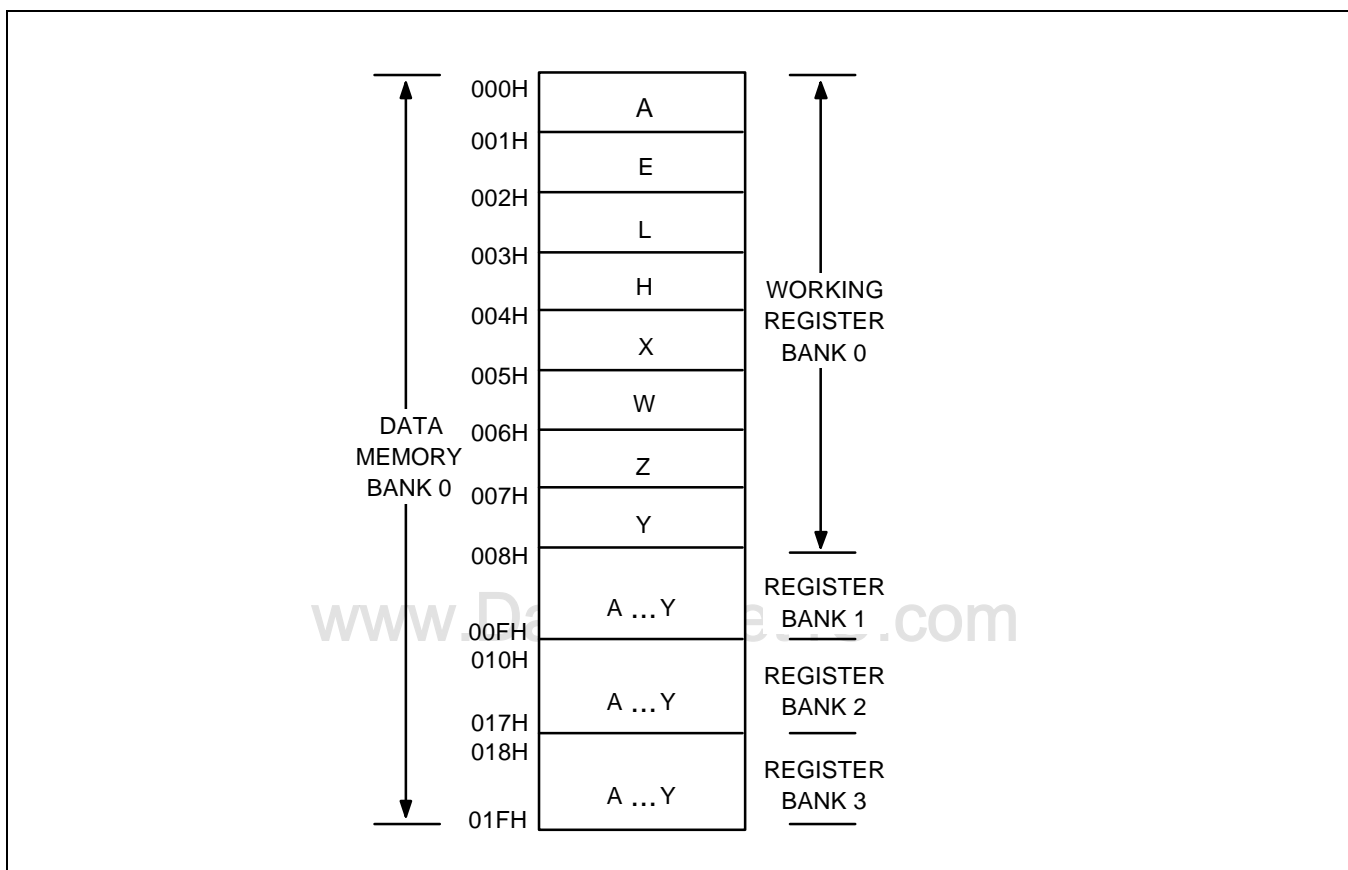

Figure 2-4. Working Register Map

### Working Register Banks

For addressing purposes, the working register area is divided into four register banks — bank 0, bank 1, bank 2, and bank 3. Any one of these banks can be selected as the working register bank by the register bank selection instruction (SRB n) and by setting the status of the register bank enable flag (ERB).

Generally, working register bank 0 is used for the main program, and banks 1, 2, and 3 for interrupt service routines. Following this convention helps to prevent possible data corruption during program execution due to contention in register bank addressing.

**Table 2-3. Working Register Organization and Addressing**

ERB Setting	SRB Settings				Selected Register Bank
	3	2	1	0	
0	0	0	–	–	Always set to bank 0
1	0	0	0	0	Bank 0
			0	1	Bank 1
			1	0	Bank 2
			1	1	Bank 3

### Paired Working Registers

Each of the register banks is subdivided into eight 4-bit registers. These registers, named Y, Z, W, X, H, L, E, and A, can either be manipulated individually using 4-bit instructions, or together as register pairs for 8-bit data manipulation.

The names of the 8-bit register pairs in each register bank are EA, HL, WX, YZ, and WL. Registers A, L, X, and Z always become the lower nibble when registers are addressed as 8-bit pairs. This makes a total of eight 4-bit registers or four 8-bit double registers in each of the four working register banks.

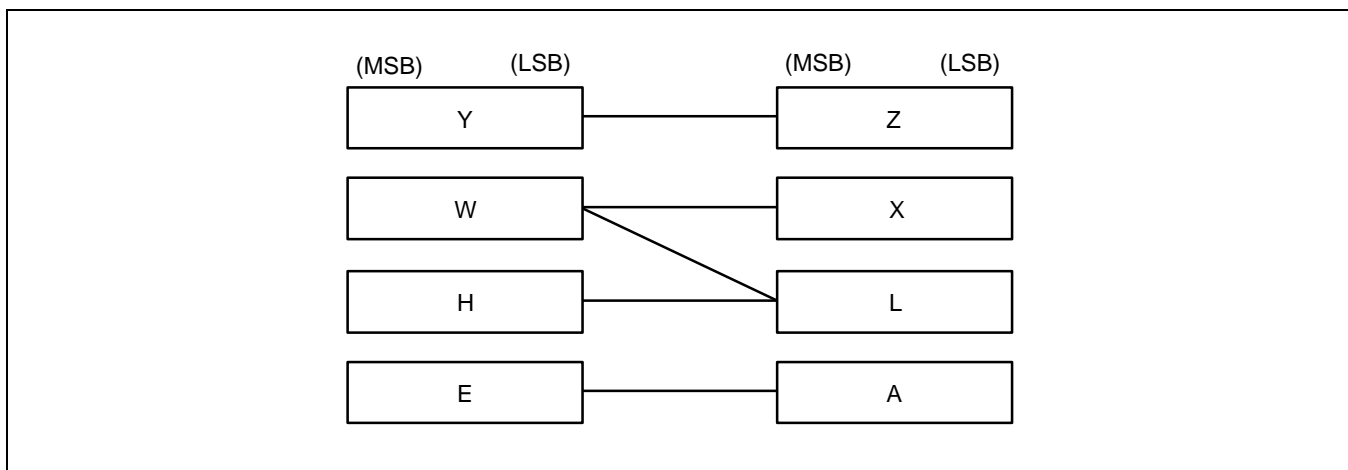

**Figure 2-5. Register Pair Configuration**

### Special-Purpose Working Registers

Register A is used as a 4-bit accumulator and double register EA as an 8-bit accumulator. The carry flag can also be used as a 1-bit accumulator.

8-bit double registers WX, WL, and HL are used as data pointers for indirect addressing. When the HL register serves as a data pointer, the instructions LDI, LDD, XCHI, and XCHD can make very efficient use of working registers as program loop counters by letting you transfer a value to the L register and increment or decrement it using a single instruction.

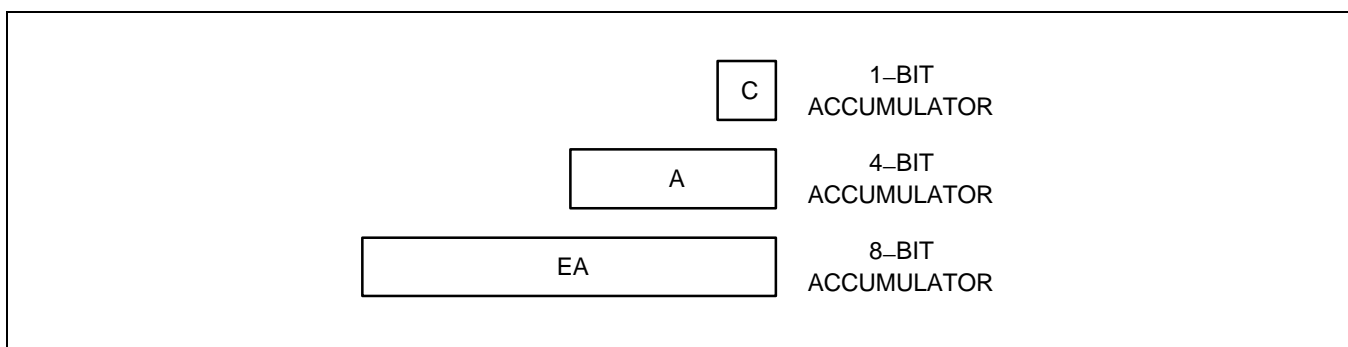

Figure 2-6. 1-Bit, 4-Bit, and 8-Bit Accumulator

### Recommendation for Multiple Interrupt Processing

If more than four interrupts are being processed at one time, you can avoid possible loss of working register data by using the PUSH RR instruction to save register contents to the stack before the service routines are executed in the same register bank. When the routines have executed successfully, you can restore the register contents from the stack to working memory using the POP instruction.

### PROGRAMMING TIP — Selecting the Working Register Area

The following examples show the correct programming method for selecting working register area:

#### 1. When ERB = "0":

```

VENT2  1,0,INT0          ; EMB ← 1, ERB ← 0, Jump to INT0 address

INT0   PUSH   SB          ; PUSH current SMB, SRB
       SRB    2           ; Instruction does not execute because ERB = "0"
       PUSH   HL          ; PUSH HL register contents to stack
       PUSH   WX          ; PUSH WX register contents to stack
       PUSH   YZ          ; PUSH YZ register contents to stack
       PUSH   EA          ; PUSH EA register contents to stack
       SMB    0
       LD     EA,#00H
       LD     80H,EA
       LD     HL,#40H
       INCS   HL
       LD     WX,EA
       LD     YZ,EA
       POP    EA          ; POP EA register contents from stack
       POP    YZ          ; POP YZ register contents from stack
       POP    WX          ; POP WX register contents from stack
       POP    HL          ; POP HL register contents from stack
       POP    SB          ; POP current SMB, SRB
       IRET

```

The POP instructions execute alternately with the PUSH instructions. If an SMB n instruction is used in an interrupt service routine, a PUSH and POP SB instruction must be used to store and restore the current SMB and SRB values, as shown in Example 2 below.

#### 2. When ERB = "1":

```

VENT2  1,1,INT0          ; EMB ← 1, ERB ← 1, Jump to INT0 address

INT0   PUSH   SB          ; Store current SMB, SRB
       SRB    2           ; Select register bank 2 because of ERB = "1"
       SMB    0
       LD     EA,#00H
       LD     80H,EA
       LD     HL,#40H
       INCS   HL
       LD     WX,EA
       LD     YZ,EA
       POP    SB          ; Restore SMB, SRB
       IRET

```

## STACK OPERATIONS

### STACK POINTER (SP)

The stack pointer (SP) is an 8-bit register that stores the address used to access the stack, an area of data memory set aside for temporary storage of data and addresses. The SP can be read or written by 8-bit control instructions. When addressing the SP, bit 0 must always remain cleared to logic zero.

F80H	SP3	SP2	SP1	"0"
F81H	SP7	SP6	SP5	SP4

There are two basic stack operations: writing to the top of the stack (push), and reading from the top of the stack (pop). A push decrements the SP and a pop increments it so that the SP always points to the top address of the last data to be written to the stack.

The program counter contents and program status word (PSW) are stored in the stack area prior to the execution of a CALL or a PUSH instruction, or during interrupt service routines. Stack operation is a LIFO (Last In-First Out) type. The stack area is located in general-purpose data memory bank 0.

During an interrupt or a subroutine, the PC value and the PSW are saved to the stack area. When the routine has completed, the stack pointer is referenced to restore the PC and PSW, and the next instruction is executed.

The SP can address stack registers in bank 0 (addresses 000H–0FFH) regardless of the current value of the enable memory bank (EMB) flag and the select memory bank (SMB) flag. Although general-purpose register areas can be used for stack operations, be careful to avoid data loss due to simultaneous use of the same register(s).

Since the reset value of the stack pointer is not defined in firmware, we recommend that you initialize the stack pointer by program code to location 00H. This sets the first register of the stack area to 0FFH.

#### NOTE

A subroutine call occupies six nibbles in the stack; an interrupt requires six. When subroutine nesting or interrupt routines are used continuously, the stack area should be set in accordance with the maximum number of subroutine levels. To do this, estimate the number of nibbles that will be used for the subroutines or interrupts and set the stack area correspondingly.

### PROGRAMMING TIP — Initializing the Stack Pointer

To initialize the stack pointer (SP):

1. When EMB = "1":

```
SMB      15          ; Select memory bank 15
LD       EA,#00H    ; Bit 0 of SP is always cleared to "0"
LD       SP,EA      ; Stack area initial address (0FFH) ← (SP) – 1
```

2. When EMB = "0":

```
LD       EA,#00H
LD       SP,EA      ; Memory addressing area (00H–7FH, F80H–FFFH)
```

## PUSH OPERATIONS

Three kinds of push operations reference the stack pointer (SP) to write data from the source register to the stack: PUSH instructions, CALL instructions, and interrupts. In each case, the SP is *decreased* by a number determined by the type of push operation and then points to the next available stack location.

### PUSH Instructions

A PUSH instruction references the SP to write two 4-bit data nibbles to the stack. Two 4-bit stack addresses are referenced by the stack pointer: one for the upper register value and another for the lower register. After the PUSH has executed, the SP is decreased *by two* and points to the next available stack location.

### CALL Instructions

When a subroutine call is issued, the CALL instruction references the SP to write the PC's contents to six 4-bit stack locations. Current values for the enable memory bank (EMB) flag and the enable register bank (ERB) flag are also pushed to the stack. Since six 4-bit stack locations are used per CALL, you may nest subroutine calls up to the number of levels permitted in the stack.

### Interrupt Routines

An interrupt routine references the SP to push the contents of the PC and the program status word (PSW) to the stack. Six 4-bit stack locations are used to store this data. After the interrupt has executed, the SP is decreased *by six* and points to the next available stack location. During an interrupt sequence, subroutines may be nested up to the number of levels which are permitted in the stack area.

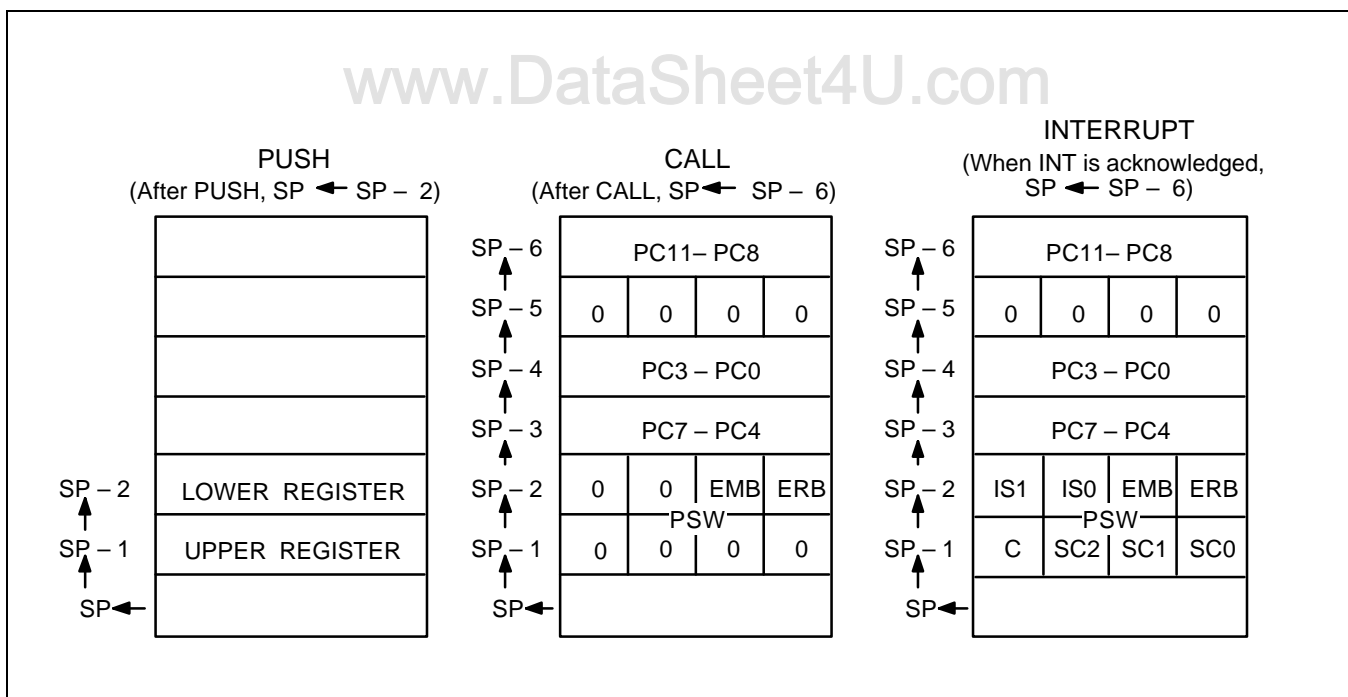

Figure 2-7. Push-Type Stack Operations

## POP OPERATIONS

For each push operation there is a corresponding pop operation to write data from the stack back to the source register or registers: for the PUSH instruction it is the POP instruction; for CALL, the instruction RET or SRET; for interrupts, the instruction IRET. When a pop operation occurs, the SP is *incremented* by a number determined by the type of operation and points to the next free stack location.

### POP Instructions

A POP instruction references the SP to write data stored in two 4-bit stack locations back to the register pairs and SB register. The value of the lower 4-bit register is popped first, followed by the value of the upper 4-bit register. After the POP has executed, the SP is incremented *by two* and points to the next free stack location.

### RET and SRET Instructions

The end of a subroutine call is signaled by the return instruction, RET or SRET. The RET or SRET uses the SP to reference the six 4-bit stack locations used for the CALL and to write this data back to the PC, the EMB, and the ERB. After the RET or SRET has executed, the SP is incremented *by six* and points to the next free stack location.

### IRET Instructions

The end of an interrupt sequence is signaled by the instruction IRET. IRET references the SP to locate the six 4-bit stack addresses used for the interrupt and to write this data back to the PC and the PSW. After the IRET has executed, the SP is incremented *by six* and points to the next free stack location.

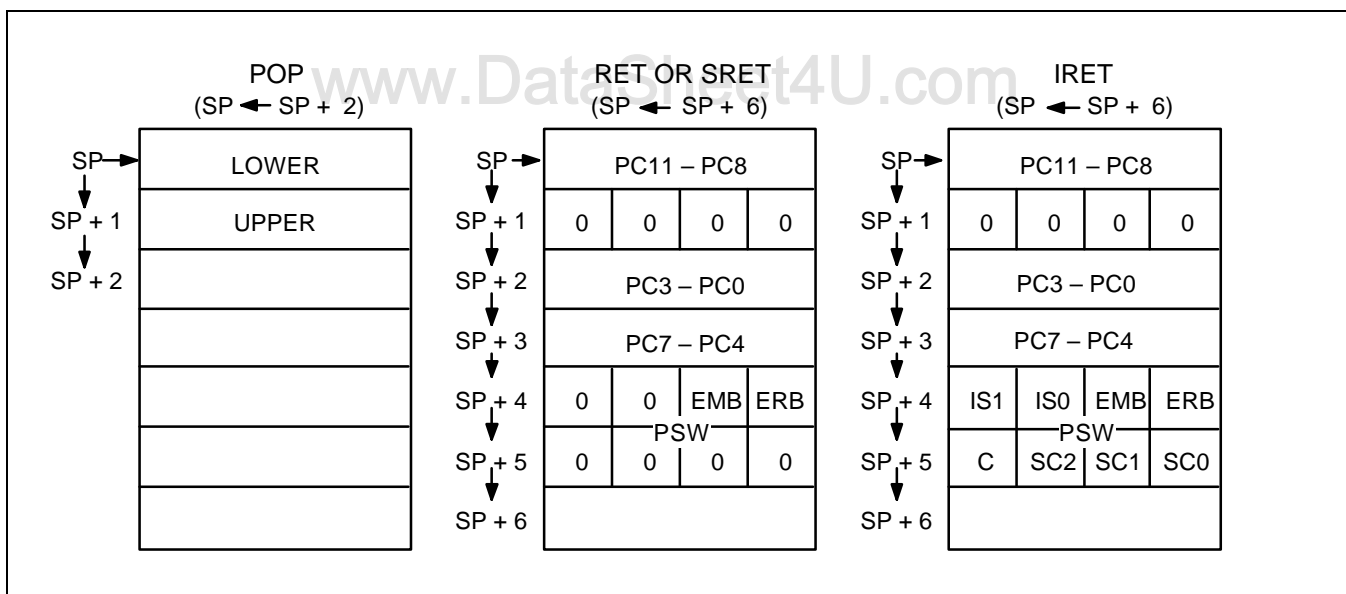

Figure 2-8. Pop-Type Stack Operations

## BIT SEQUENTIAL CARRIER (BSC)

The bit sequential carrier (BSC) is a 16-bit general register that can be manipulated using 1-, 4-, and 8-bit RAM control instructions. RESET clears all BSC bit values to logic zero.

Using the BSC, you can specify sequential addresses and bit locations using 1-bit indirect addressing (memb.@L). (Bit addressing is independent of the current EMB value.) In this way, programs can process 16-bit data by moving the bit location sequentially and then incrementing or decreasing the value of the L register.

BSC data can also be manipulated using direct addressing. For 8-bit manipulations, the 4-bit register names BSC0 and BSC2 must be specified and the upper and lower 8 bits manipulated separately.

If the values of the L register are 0H at BSC0.@L, the address and bit location assignment is FC0H.0. If the L register content is FH at BSC0.@L, the address and bit location assignment is FC3H.3.

**Table 2-4. BSC Register Organization**

Name	Address	Bit 3	Bit 2	Bit 1	Bit 0
BSC0	FC0H	BSC0.3	BSC0.2	BSC0.1	BSC0.0
BSC1	FC1H	BSC1.3	BSC1.2	BSC1.1	BSC1.0
BSC2	FC2H	BSC2.3	BSC2.2	BSC2.1	BSC2.0
BSC3	FC3H	BSC3.3	BSC3.2	BSC3.1	BSC3.0

### PROGRAMMING TIP — Using the BSC Register to Output 16-Bit Data

To use the bit sequential carrier (BSC) register to output 16-bit data (5937H) to the P3.0 pin:

```

BITS      EMB
SMB       15
LD        EA,#37H          ;
LD        BSC0,EA         ; BSC0 ← A, BSC1 ← E
LD        EA,#59H         ;
LD        BSC2,EA         ; BSC2 ← A, BSC3 ← E
SMB       0
LD        L,#0H           ;
AGN       LDB C,BSC0.@L   ;
LDB       P3.0,C          ; P3.0 ← C
INCS     L
JR        AGN
RET

```



## PROGRAM COUNTER (PC)

A 12-bit program counter (PC) stores addresses for instruction fetches during program execution. Whenever a reset operation or an interrupt occurs, bits PC11 through PC0 are set to the vector address.

Usually, the PC is incremented by the number of bytes of the instruction being fetched. One exception is the 1-byte REF instruction which is used to reference instructions stored in the ROM.

## PROGRAM STATUS WORD (PSW)

The program status word (PSW) is an 8-bit word that defines system status and program execution status and which permits an interrupted process to resume operation after an interrupt request has been serviced. PSW values are mapped as follows:

	(MSB)		(LSB)	
FB0H	IS1	IS0	EMB	ERB
FB1H	C	SC2	SC1	SC0

The PSW can be manipulated by 1-bit or 4-bit read/write and by 8-bit read instructions, depending on the specific bit or bits being addressed. The PSW can be addressed during program execution regardless of the current value of the enable memory bank (EMB) flag.

Part or all of the PSW is saved to stack prior to execution of a subroutine call or hardware interrupt. After the interrupt has been processed, the PSW values are popped from the stack back to the PSW address.

When a RESET is generated, the EMB and ERB values are set according to the RESET vector address, and the carry flag is left undefined (or the current value is retained). PSW bits IS0, IS1, SC0, SC1, and SC2 are all cleared to logical zero.

**Table 2-5. Program Status Word Bit Descriptions**

PSW Bit Identifier	Description	Bit Addressing	Read/Write
IS1, IS0	Interrupt status flags	1, 4	R/W
EMB	Enable memory bank flag	1	R/W
ERB	Enable register bank flag	1	R/W
C	Carry flag	1	R/W
SC2, SC1, SC0	Program skip flags	8	R

## INTERRUPT STATUS FLAGS (IS0, IS1)

PSW bits IS0 and IS1 contain the current interrupt execution status values. You can manipulate IS0 and IS1 flags directly using 1-bit RAM control instructions

By manipulating interrupt status flags in conjunction with the interrupt priority register (IPR), you can process multiple interrupts by anticipating the next interrupt in an execution sequence. The interrupt priority control circuit determines the IS0 and IS1 settings in order to control multiple interrupt processing. When both interrupt status flags are set to "0", all interrupts are allowed. The priority with which interrupts are processed is then determined by the IPR.

When an interrupt occurs, IS0 and IS1 are pushed to the stack as part of the PSW and are automatically incremented to the next higher priority level. Then, when the interrupt service routine ends with an IRET instruction, IS0 and IS1 values are restored to the PSW. Table 2-6 shows the effects of IS0 and IS1 flag settings.

**Table 2-6. Interrupt Status Flag Bit Settings**

IS1 Value	IS0 Value	Status of Currently Executing Process	Effect of IS0 and IS1 Settings on Interrupt Request Control
0	0	0	All interrupt requests are serviced
0	1	1	Only high-priority interrupt(s) as determined in the interrupt priority register (IPR) are serviced
1	0	2	No more interrupt requests are serviced
1	1	–	Not applicable; these bit settings are undefined

Since interrupt status flags can be addressed by write instructions, programs can exert direct control over interrupt processing status. Before interrupt status flags can be addressed, however, you must first execute a DI instruction to inhibit additional interrupt routines. When the bit manipulation has been completed, execute an EI instruction to re-enable interrupt processing.

### PROGRAMMING TIP — Setting ISx Flags for Interrupt Processing

The following instruction sequence shows how to use the IS0 and IS1 flags to control interrupt processing:

```

INTB      DI          ; Disable interrupt
BITR      IS1        ; IS1 ← 0
BITS      IS0        ; Allow interrupts according to IPR priority level
EI        ; Enable interrupt

```

**EMB FLAG (EMB)**

The EMB flag is used to allocate specific address locations in the RAM by modifying the upper 4 bits of 12-bit data memory addresses. In this way, it controls the addressing mode for data memory banks 0, 1, or 15.

When the EMB flag is "0", the data memory address space is restricted to bank 15 and addresses 000H–07FH of memory bank 0, regardless of the SMB register contents. When the EMB flag is set to "1", the general-purpose areas of bank 0, 1, and 15 can be accessed by using the appropriate SMB value.

**PROGRAMMING TIP — Using the EMB Flag to Select Memory Banks**

EMB flag settings for memory bank selection:

## 1. When EMB = "0":

SMB	1	; Non-essential instruction since EMB = "0"
LD	A,#9H	
LD	90H,A	; (F90H) ← A, bank 15 is selected
LD	34H,A	; (034H) ← A, bank 0 is selected
SMB	0	; Non-essential instruction since EMB = "0"
LD	90H,A	; (F90H) ← A, bank 15 is selected
LD	34H,A	; (034H) ← A, bank 0 is selected
SMB	15	; Non-essential instruction, since EMB = "0"
LD	20H,A	; (020H) ← A, bank 0 is selected
LD	90H,A	; (F90H) ← A, bank 15 is selected

## 2. When EMB = "1":

SMB	1	; Select memory bank 1
LD	A,#9H	
LD	0E0H,A	; (1E0H) ← A, bank 1 is selected
LD	0F0H,A	; (1F0H) ← A, bank 1 is selected
SMB	0	; Select memory bank 0
LD	90H,A	; (090H) ← A, bank 0 is selected
LD	34H,A	; (034H) ← A, bank 0 is selected
SMB	15	; Select memory bank 15
LD	20H,A	; Program error, but assembler does not detect it
LD	90H,A	; (F90H) ← A, bank 15 is selected

**ERB FLAG (ERB)**

The 1-bit register bank enable flag (ERB) determines the range of addressable working register area. When the ERB flag is "1", the working register area from register banks 0 to 3 is selected according to the register bank selection register (SRB). When the ERB flag is "0", register bank 0 is the selected working register area, regardless of the current value of the register bank selection register (SRB).

When an internal reset is generated, bit 6 of program memory address 0000H is written to the ERB flag. This automatically initializes the flag. When a vectored interrupt is generated, bit 6 of the respective address table in program memory is written to the ERB flag, setting the correct flag status before the interrupt service routine is executed.

During the interrupt routine, the ERB value is automatically pushed to the stack area along with the other PSW bits. Afterwards, it is popped back to the FB0H.0 bit location. The initial ERB flag settings for each vectored interrupt are defined using VENTn instructions.

** PROGRAMMING TIP — Using the ERB Flag to Select Register Banks**

ERB flag settings for register bank selection:

1. When ERB = "0":

SRB	1	; Register bank 0 is selected (since ERB = "0", the
		; SRB is configured to bank 0)
LD	EA,#34H	; Bank 0 EA ← #34H
LD	HL,EA	; Bank 0 HL ← EA
SRB	2	; Register bank 0 is selected
LD	YZ,EA	; Bank 0 YZ ← EA
SRB	3	; Register bank 0 is selected
LD	WX,EA	; Bank 0 WX ← EA

2. When ERB = "1":

SRB	1	; Register bank 1 is selected
LD	EA,#34H	; Bank 1 EA ← #34H
LD	HL,EA	; Bank 1 HL ← Bank 1 EA
SRB	2	; Register bank 2 is selected
LD	YZ,EA	; Bank 2 YZ ← BANK2 EA
SRB	3	; Register bank 3 is selected
LD	WX,EA	; Bank 3 WX ← Bank 3 EA

### SKIP CONDITION FLAGS (SC2, SC1, SC0)

The skip condition flags SC2, SC1, and SC0 in the PSW indicate the current program skip conditions and are set and reset automatically during program execution. Skip condition flags can only be addressed by 8-bit read instructions. Direct manipulation of the SC2, SC1, and SC0 bits is not allowed.

### CARRY FLAG (C)

The carry flag is used to save the result of an overflow or borrow when executing arithmetic instructions involving a carry (ADC, SBC). The carry flag can also be used as a 1-bit accumulator for performing Boolean operations involving bit-addressed data memory.

If an overflow or borrow condition occurs when executing arithmetic instructions with carry (ADC, SBC), the carry flag is set to "1". Otherwise, its value is "0". When a RESET occurs, the current value of the carry flag is retained during power-down mode, but when normal operating mode resumes, its value is undefined.

The carry flag can be directly manipulated by predefined set of 1-bit read/write instructions, independent of other bits in the PSW. Only the ADC and SBC instructions, and the instructions listed in Table 2-7, affect the carry flag.

**Table 2-7. Valid Carry Flag Manipulation Instructions**

Operation Type	Instructions	Carry Flag Manipulation
Direct manipulation	SCF	Set carry flag to "1"
	RCF	Clear carry flag to "0" (reset carry flag)
	CCF	Invert carry flag value (complement carry flag)
	BTST C	Test carry and skip if C = "1"
Bit transfer	LDB (operand) <sup>(1)</sup> , C	Load carry flag value to the specified bit
	LDB C, (operand) <sup>(1)</sup>	Load contents of the specified bit to carry flag
Boolean manipulation	BAND C, (operand) <sup>(1)</sup>	AND the specified bit with contents of carry flag and save the result to the carry flag
	BOR C, (operand) <sup>(1)</sup>	OR the specified bit with contents of carry flag and save the result to the carry flag
	BXOR C, (operand) <sup>(1)</sup>	XOR the specified bit with contents of carry flag and save the result to the carry flag
Interrupt routine	INTn <sup>(2)</sup>	Save carry flag to stack with other PSW bits
Return from interrupt	IRET	Restore carry flag from stack with other PSW bits

#### NOTES:

1. The operand has three bit addressing formats: mema.a, memb.@L, and @H + DA.b.
2. 'INTn' refers to the specific interrupt being executed and is not an instruction.

### PROGRAMMING TIP — Using the Carry Flag as a 1-Bit Accumulator

1. Set the carry flag to logic one:

```

SCF                ; C ← 1
LD      EA,#0C3H   ; EA ← #0C3H
LD      HL,#0AAH   ; HL ← #0AAH
ADC     EA,HL      ; EA ← #0C3H + #0AAH + #1H, C ← 1

```

2. Logical-AND bit 3 of address 3FH with P3.3 and output the result to P2.0:

```

LD      H,#3H      ; Set the upper four bits of the address to the H register
                          ; value
LDB     C,@H+0FH.3 ; C ← bit 3 of 3FH
BAND    C,P3.3     ; C ← C AND P3.3
LDB     P2.0,C     ; Output result from carry flag to P2.0

```

www.DataSheet4U.com

# 3 ADDRESSING MODES

## OVERVIEW

The enable memory bank flag, EMB, controls the two addressing modes for data memory. When the EMB flag is set to logic one, you can address the entire RAM area; when the EMB flag is cleared to logic zero, the addressable area in the RAM is restricted to specific locations.

The EMB flag works in connection with the select memory bank instruction, SMB n. You will recall that the SMB n instruction is used to select RAM bank 0, 1, or 15. The SMB setting is always contained in the upper four bits of a 12-bit RAM address. For this reason, both addressing modes (EMB = "0" and EMB = "1") apply specifically to the memory bank indicated by the SMB instruction, and any restrictions to the addressable area within banks 0, 1, or 15. Direct and indirect 1-bit, 4-bit, and 8-bit addressing methods can be used. Several RAM locations are addressable at all times, regardless of the current EMB flag setting.

Here are a few guidelines to keep in mind regarding data memory addressing:

- When you address peripheral hardware locations in bank 15, the mnemonic for the memory-mapped hardware component can be used as the operand in place of the actual address location.
- Always use an even-numbered RAM address as the operand in 8-bit direct and indirect addressing.
- With direct addressing, use the RAM address as the instruction operand; with indirect addressing, the instruction specifies a register which contains the operand's address.

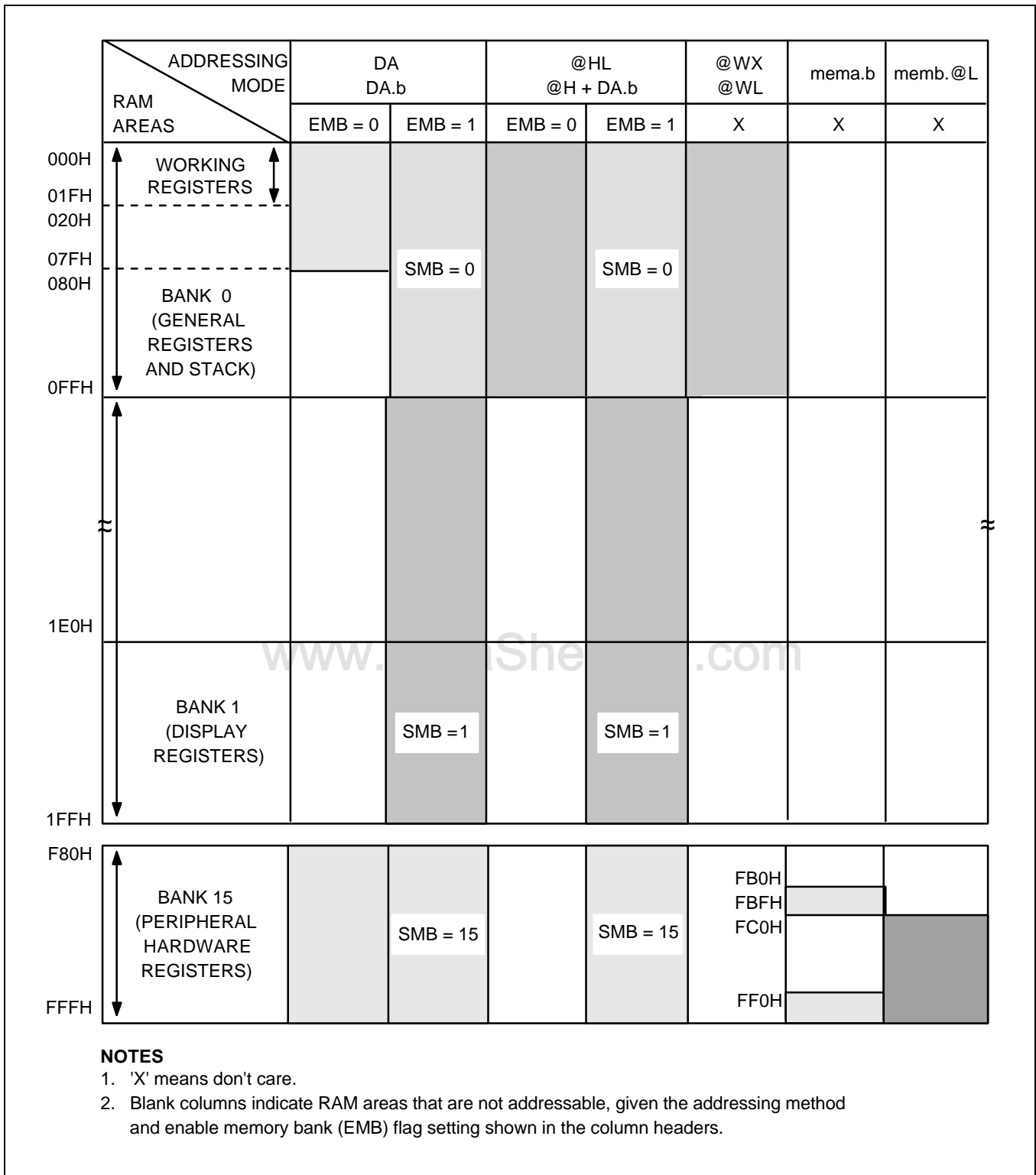

Figure 3-1. RAM Address Structure



## EMB AND ERB INITIALIZATION VALUES

The EMB and ERB flag bits are set automatically by the values of the RESET vector address and the interrupt vector address. When a RESET is generated internally, bit 7 of program memory address 0000H is written to the EMB flag, initializing it automatically. When a vectored interrupt is generated, bit 7 of the respective vector address table is written to the EMB. This automatically sets the EMB flag status for the interrupt service routine. When the interrupt is serviced, the EMB value is automatically saved to stack and then restored when the interrupt routine has completed.

At the beginning of a program, the initial EMB and ERB flag values for each vectored interrupt must be set by using VENT instruction. The EMB and ERB can be set or reset by bit manipulation instructions (BITS, BITR) despite the current SMB setting.

### PROGRAMMING TIP — Initializing the EMB and ERB Flags

The following assembly instructions show how to initialize the EMB and ERB flag settings:

```

ORG      0000H           ; ROM address assignment
VENT0    1,0,RESET      ; EMB ← 1, ERB ← 0, branch RESET
VENT1    0,1,INTB       ; EMB ← 0, ERB ← 1, branch INTB
VENT2    0,1,INT0       ; EMB ← 0, ERB ← 1, branch INT0
VENT3    0,1,INT1       ; EMB ← 0, ERB ← 1, branch INT1
ORG      000AH           ; ROM address assignment
VENT5    0,1,INTT0      ; EMB ← 0, ERB ← 1, branch INTT0
•
•
•
RESET    BITR           EMB

```

www.DataSheet4U.com

**ENABLE MEMORY BANK SETTINGS****EMB = "1"**

When the enable memory bank flag EMB is set to logic one, you can address the data memory bank specified by the select memory bank (SMB) value (0, 1, or 15) using 1-, 4-, or 8-bit instructions. You can use both direct and indirect addressing modes. The addressable RAM areas when EMB = "1" are as follows:

If SMB = 0,	000H–0FFH
If SMB = 1,	1E0H–1FFH
If SMB = 15,	F80H–FFFH

**EMB = "0"**

When the enable memory bank flag EMB is set to logic zero, the addressable area is defined independently of the SMB value, and is restricted to specific locations depending on whether a direct or indirect address mode is used.

If EMB = "0", the addressable area is restricted to locations 000H–07FH in bank 0 and to locations F80H–FFFH in bank 15 for direct addressing. For indirect addressing, only locations 000H–0FFH in bank 0 are addressable, regardless of SMB value.

To address the peripheral hardware register (bank 15) using indirect addressing, the EMB flag must first be set to "1" and the SMB value to "15". When a RESET occurs, the EMB flag is set to the value contained in bit 7 of ROM address 0000H.

**EMB-Independent Addressing**

At any time, several areas of the data memory can be addressed independent of the current status of the EMB flag. These exceptions are described in Table 3-1.

**Table 3-1. RAM Addressing Not Affected by the EMB Value**

Address	Addressing Method	Affected Hardware	Program Examples
000H–0FFH	4-bit indirect addressing using WX and WL register pairs; 8-bit indirect addressing using SP	Not applicable	LD A,@WX PUSH EA POP EA
FB0H–FBFH FF0H–FFFH	1-bit direct addressing	PSW, SCMOD, IE <sub>x</sub> , IRQ <sub>x</sub> , I/O	BITS EMB BITR IE4
FC0H–FFFH	1-bit indirect addressing using the L register	BSC, I/O	BTST FC3H.@L BAND C,P3.@L

### SELECT BANK REGISTER (SB)

The select bank register (SB) is used to assign the memory bank and register bank. The 8-bit SB register consists of the 4-bit select register bank register (SRB) and the 4-bit select memory bank register (SMB), as shown in Figure 3-2.

During interrupts and subroutine calls, SB register contents can be saved to stack in 8-bit units by the PUSH SB instruction. You later restore the value to the SB using the POP SB instruction.

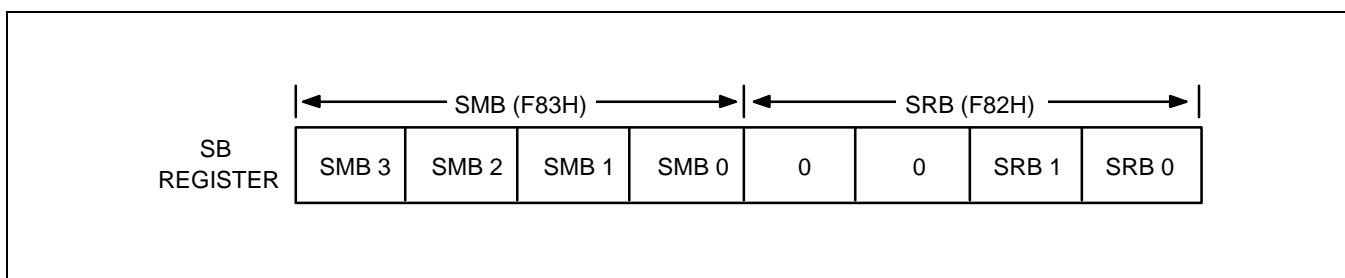

Figure 3-2. SMB and SRB Values in the SB Register

#### Select Register Bank (SRB) Instruction

The select register bank (SRB) value specifies which register bank is to be used as a working register bank. The SRB value is set by the 'SRB n' instruction, where n = 0, 1, 2, and 3.

One of the four register banks is selected by the combination of ERB flag status and the SRB value that is set using the 'SRB n' instruction. The current SRB value is retained until another register is requested by program software. PUSH SB and POP SB instructions are used to save and restore the contents of SRB during interrupts and subroutine calls. RESET clears the 4-bit SRB value to logic zero.

#### Select Memory Bank (SMB) Instruction

To select one of the four available data memory banks, you must execute an SMB n instruction specifying the number of the memory bank you want (0, 1, or 15). For example, the instruction 'SMB 1' selects bank 1 and 'SMB 15' selects bank 15. (And remember to enable the selected memory bank by making the appropriate EMB flag setting.)

The upper four bits of the 12-bit data memory address are stored in the SMB register. If the SMB value is not specified by software (or if a RESET does not occur) the current value is retained. RESET clears the 4-bit SMB value to logic zero.

The PUSH SB and POP SB instructions save and restore the contents of the SMB register to and from the stack area during interrupts and subroutine calls.

## DIRECT AND INDIRECT ADDRESSING

1-bit, 4-bit, and 8-bit data stored in data memory locations can be addressed directly using a specific register or bit address as the instruction operand.

Indirect addressing specifies a memory location that contains the required direct address. The KS57 instruction set supports 1-bit, 4-bit, and 8-bit indirect addressing. For 8-bit indirect addressing, an even-numbered RAM address must always be used as the instruction operand.

## 1-BIT ADDRESSING

**Table 3-2. 1-Bit Direct and Indirect RAM Addressing**

Operand Notation	Addressing Mode Description	EMB Flag Setting	Addressable Area	Memory Bank	Hardware I/O Mapping
DA.b	Direct: bit is indicated by the RAM address (DA), memory bank selection, and specified bit number (b).	0	000H–07FH	Bank 0	–
			F80H–FFFH	Bank 15	All 1-bit addressable peripherals (SMB = 15)
		1	000H–0FFH	Bank 0	
			1E0H–1FFH	Bank 1	
F80H–FFFH	Bank 15				
	mema.b	Direct: bit is indicated by addressable area (mema) and bit number (b).	x	FB0H–FBFH FF0H–FFFH	Bank 15
memb.@L	Indirect: lower two bits of register L as indicated by the upper 6 bits of RAM area (memb) and the upper two bits of register L.	x	FC0H–FFFH	Bank 15	BSCn.x Pn.n
@H + DA.b	Indirect: bit indicated by the lower four bits of the address (DA), memory bank selection, and the H register identifier.	0	000H–0FFH	Bank 0	–
			1	000H–0FFH	Bank 0
		1E0H–1FFH		Bank 1	
		F80H–FFFH		Bank 15	

**NOTE:** x = not applicable.

## PROGRAMMING TIP — 1-Bit Addressing Modes

### 1-Bit Direct Addressing

#### 1. If EMB = "0":

```

AFLAG EQU 34H.3
BFLAG EQU 85H.3
CFLAG EQU 0BAH.0
SMB 0
BITS AFLAG ; 34H.3 ← 1
BITS BFLAG ; 85H.3 ← 1
BTST CFLAG ; If FBAH.0 = 1, skip
BITS BFLAG ; Else if, FBAH.0 = 0, F85H.3 (BMOD.3) ← 1
BITS P3.0 ; FF3H.0 (P3.0) ← 1

```

#### 2. If EMB = "1":

```

AFLAG EQU 34H.3
BFLAG EQU 85H.3
CFLAG EQU 0BAH.0
SMB 0
BITS AFLAG ; 34H.3 ← 1
BITS BFLAG ; 85H.3 ← 1
BTST CFLAG ; If 0BAH.0 = 1, skip
BITS BFLAG ; Else if 0BAH.0 = 0, 085H.3 ← 1
BITS P3.0 ; FF3H.0 (P3.0) ← 1

```

### 1-Bit Indirect Addressing

#### 1. If EMB = "0":

```

AFLAG EQU 34H.3
BFLAG EQU 85H.3
CFLAG EQU 0BAH.0
SMB 0
LD H,#0BH ; H ← #0BH
BTSTZ @H+CFLAG ; If 0BAH.0 = 1, 0BAH.0 ← 0 and skip
BITS CFLAG ; Else if 0BAH.0 = 0, FBAH.0 ← 1

```

#### 2. If EMB = "1":

```

AFLAG EQU 34H.3
BFLAG EQU 85H.3
CFLAG EQU 0BAH.0
SMB 0
LD H,#0BH ; H ← #0BH
BTSTZ @H+CFLAG ; If 0BAH.0 = 1, 0BAH.0 ← 0 and skip
BITS CFLAG ; Else if 0BAH.0 = 0, 0BAH.0 ← 1

```

## 4-BIT ADDRESSING

Table 3-3. 4-Bit Direct and Indirect RAM Addressing

Operand Notation	Addressing Mode Description	EMB Flag Setting	Addressable Area	Memory Bank	Hardware I/O Mapping
DA	Direct: 4-bit address indicated by the RAM address (DA) and the memory bank selection	0	000H–07FH	Bank 0	–
			F80H–FFFH	Bank 15	All 4-bit addressable peripherals (SMB = 15)
		1	000H–0FFH	Bank 0	
			1E0H–1FFH F80H–FFFH	Bank 1 Bank 15	
@HL	Indirect: 4-bit address indicated by the memory bank selection and register HL	0	000H–0FFH	Bank 0	–
		1	000H–0FFH	Bank 0	All 4-bit addressable peripherals (SMB = 15)
			1E0H–1FFH F80H–FFFH	Bank 1 Bank 15	
@WX	Indirect: 4-bit address indicated by register WX	x	000H–0FFH	Bank 0	–
@WL	Indirect: 4-bit address indicated by register WL	x	000H–0FFH	Bank 0	–

**NOTE:** x = not applicable.

www.DataSheet4U.com

## PROGRAMMING TIP — 4-Bit Addressing Modes

### 4-Bit Direct Addressing

1. If EMB = "0":

```

ADATA EQU 46H
BDATA EQU 8EH
SMB 15 ; Non-essential instruction, since EMB = "0"
LD A,P3 ; A ← (P3)
SMB 0 ; Non-essential instruction, since EMB = "0"
LD ADATA,A ; (046H) ← A
LD BDATA,A ; (F8EH (LCON)) ← A

```

2. If EMB = "1":

```

ADATA EQU 46H
BDATA EQU 8EH
SMB 15
LD A,P3 ; A ← (P3)
SMB 0
LD ADATA,A ; (046H) ← A
LD BDATA,A ; (08EH) ← A

```

### 4-Bit Indirect Addressing

1. If EMB = "0", compare bank 0 locations 040H–046H with bank 0 locations 060H–066H:

```

ADATA EQU 46H
BDATA EQU 66H
SMB 1 ; Non-essential instruction, since EMB = "0"
LD HL,#BDATA
LD WX,#ADATA
COMP LD A,@WL ; A ← bank 0 (040H–046H)
CPSE A,@HL ; If bank 0 (060H–066H) = A, skip
SRET
DECS L
JR COMP
RET

```

2. If EMB = "0", exchange bank 0 locations 040H–046H with bank 0 locations 060H–066H:

```

ADATA EQU 46H
BDATA EQU 66H
SMB 1 ; Non-essential instruction, since EMB = "0"
LD HL,#BDATA
LD WX,#ADATA
TRANS LD A,@WL ; A ← bank 0 (040H–046H)
XCHD A,@HL ; Bank 0 (060H–066H) ↔ A
JR TRANS

```

## 8-BIT ADDRESSING

Table 3-4. 8-Bit Direct and Indirect RAM Addressing

Instruction Notation	Addressing Mode Description	EMB Flag Setting	Addressable Area	Memory Bank	Hardware I/O Mapping
DA	Direct: 8-bit address indicated by the RAM address ( <i>DA = even number</i> ) and memory bank selection	0	000H–07FH	Bank 0	All 8-bit addressable peripherals (SMB = 15)
			F80H–FFFH	Bank 15	
		1	000H–0FFH	Bank 0	
			1E0H–1FFH	Bank 1	
@HL	Indirect: the 8-bit address 4-bit indicated by the memory bank selection and register HL; (the L register value must be an even number)	0	000H–0FFH	Bank 0	All 8-bit addressable peripherals (SMB = 15)
			F80H–FFFH	Bank 15	
		1	000H–0FFH	Bank 0	
			1E0H–1FFH	Bank 1	
		F80H–FFFH	Bank 15		

www.DataSheet4U.com



## PROGRAMMING TIP — 8-Bit Addressing Modes

### 8-Bit Direct Addressing

1. If EMB = "0":

```

ADATA EQU 46H
BDATA EQU 8EH
LD EA, #0FFH
SMB 0
LD ADATA,EA ; (046H) ← A, (047H) ← E
LD BDATA,EA ; (F8EH) ← A, (F8FH) ← E

```

2. If EMB = "1":

```

ADATA EQU 46H
BDATA EQU 8EH
SMB 0
LD EA, #0FFH
LD ADATA,EA ; (046H) ← A, (047H) ← E
LD BDATA,EA ; (08EH) ← A, (08FH) ← E

```

### 8-Bit Indirect Addressing

1. If EMB = "0":

```

ADATA EQU 46H
SMB 1 ; Non-essential instruction, since EMB = "0"
LD HL,#ADATA
LD EA,@HL ; A ← (046H), E ← (047H)

```



NOTES

www.DataSheet4U.com

# 4

## MEMORY MAP

### OVERVIEW

To support program control of peripheral hardware, I/O addresses for peripherals are memory-mapped to bank 15 of the RAM. Memory mapping lets you use a mnemonic as the operand of an instruction in place of the specific memory location.

Access to bank 15 is controlled by the select memory bank (SMB) instruction and by the enable memory bank flag (EMB) setting. If the EMB flag is "0", bank 15 can be addressed using direct addressing, regardless of the current SMB value. 1-bit direct and indirect addressing can be used for specific locations in bank 15, regardless of the current EMB value.

### I/O MAP FOR HARDWARE REGISTERS

Table 4-1 contains detailed information about I/O mapping for peripheral hardware in bank 15 (register locations F80H–FFFH). Use the I/O map as a quick-reference source when writing application programs. The I/O map gives you the following information:

- Register address
- Register name (mnemonic for program addressing)
- Bit values (both addressable and non-manipulable)
- Read-only, write-only, or read and write addressability
- 1-bit, 4-bit, or 8-bit data manipulation characteristics

## MEMORY MAP

## KS57C2302/C2304/P2304 MICROCONTROLLER

Table 4-1. I/O Map for Memory Bank 15

Memory Bank 15							Addressing Mode		
Address	Register	Bit 3	Bit 2	Bit 1	Bit 0	R/W	1-Bit	4-Bit	8-Bit
F80H	SP	.3	.2	.1	"0"	R/W	No	No	Yes
F81H		.7	.6	.5	.4				
Locations F82H–F84H are not mapped.									
F85H	BMOD	.3	.2	.1	.0	W	.3	Yes	No
F86H	BCNT	.3	.2	.1	.0	R	No	No	Yes
F87H		.7	.6	.5	.4				
F88H	WMOD	.3	.2	.1	.0	W	.3 (1)	No	Yes
F89H		.7	"0"	.5	.4				
Locations F8AH–F8BH are not mapped.									
F8CH	LMOD	.3	.2	.1	.0	W	.3	No	Yes
F8DH		.7	.6	.5	.4				
F8EH	LCON	"0" (4)	.2	"0"	.0	W	No	Yes	No
Location F8FH is not mapped.									
F90H	TMOD0	.3	.2	"0"	"0"	W	.3	No	Yes
F91H		"0"	.6	.5	.4				
F92H		"u" (4)	TOE0	"u" (4)	"u" (4)	R/W	Yes	No	No
Location F93H is not mapped.									
F94H	TCNT0	.3	.2	.1	.0	R	No	No	Yes
F95H		.7	.6	.5	.4				
F96H	TREF0	.3	.2	.1	.0	W	No	No	Yes
F97H		.7	.6	.5	.4				
F98H	WDMOD	.3	.2	.1	.0	W	No	No	Yes
F99H		.7	.6	.5	.4				
F9AH	WDFLAG	.3	"0"	"0"	"0"	W	Yes	Yes	No
Locations F9BH–FAFH are not mapped.									
FB0H	PSW	IS1	IS0	EMB	ERB	R/W	Yes	Yes	Yes
FB1H		C (2)	SC2	SC1	SC0	R	No	No	
FB2H	IPR	IME	.2	.1	.0	W	IME	Yes	No
FB3H	PCON	.3	.2	.1	.0	W	No	Yes	No
FB4H	IMOD0	.3	"0"	.1	.0	W	No	Yes	No
FB5H	IMOD1	"0"	"0"	"0"	.0				
FB6H	IMOD2	"0"	"0"	.1	.0				
FB7H	SCMOD	.3	.2	"0"	.0	W	Yes	No	No

Table 4-1. I/O Map for Memory Bank 15 (Continued)

Memory Bank 15							Addressing Mode		
Address	Register	Bit 3	Bit 2	Bit 1	Bit 0	R/W	1-Bit	4-Bit	8-Bit
FB8H	INT (A)	"0"	"0"	IEB	IRQB	R/W	Yes	Yes	No
Location FB9H is not mapped									
FBAH	INT (B)	"0"	"0"	IEW	IRQW	R/W	Yes	Yes	No
Location FBBH is not mapped.									
FBCH	INT (C)	"0"	"0"	IET0	IRQT0	R/W	Yes	Yes	No
Location FBDH is not mapped.									
FBEH	INT (E)	IE1	IRQ1	IE0	IRQ0	R/W	Yes	Yes	No
FBFH	INT (F)	"0"	"0"	IE2	IRQ2				
FC0H	BSC0	.3	.2	.1	.0	R/W	Yes	Yes	Yes
FC1H	BSC1	.3	.2	.1	.0				
FC2H	BSC2	.3	.2	.1	.0				
FC3H	BSC3	.3	.2	.1	.0				
FD0H	CLMOD	.3	"0"	.1	.0	W	No	Yes	No
Locations FD1H–FDBH are not mapped.									
FDCH	PUMOD	PM.3	PM.2	PM.1	"0"	W	No	No	Yes
FDDH		"0"	PM.6	"0"	"0"				
Locations FDEH–FE7H are not mapped.									
FE8H	PMG1	PM3.3	PM3.2	PM3.1	PM3.0	W	No	No	Yes
FE9H		PM6.3	PM6.2	PM6.1	PM6.0				
Locations FEAH–FEBH are not mapped.									
FECH	PMG2	"0"	PM2	"0"	"0"	W	No	No	Yes
FEDH		"0"	"0"	"0"	"0"				
Locations FEEH–FF0H are not mapped.									
FF1H	Port 1	.3	.2	.1	.0	R	Yes	Yes	No
FF2H	Port 2	.3	.2	.1	.0	R/W	Yes	Yes	No
FF3H	Port 3	.3	.2	.1	.0	R/W	Yes	Yes	No
Locations FF4H–FF5H are not mapped.									
FF6H	Port 6	.3	.2	.1	.0	R/W	Yes	Yes	No
Locations FF7H–FFFH are not mapped.									

**NOTES:**

1. Bit 3 in the WMOD register is read only.
2. The carry flag can be read or written by specific bit manipulation instructions only.
3. The LCON.3 register must be set to "0".
4. "u" means that the value is undetermined.

## REGISTER DESCRIPTIONS

In this section, register descriptions are presented in a consistent format to familiarize you with the memory-mapped I/O locations in bank 15 of the RAM. Figure 4-1 describes features of the register description format. Register descriptions are arranged in alphabetical order. Programmers can use this section as a quick-reference source when writing application programs.

Counter registers and reference registers, as well as the stack pointer and port I/O latches, are not included in these descriptions. More detailed information about how these registers are used is included in Part II of this manual, "Hardware Descriptions," in the context of the corresponding peripheral hardware module descriptions.

www.DataSheet4U.com

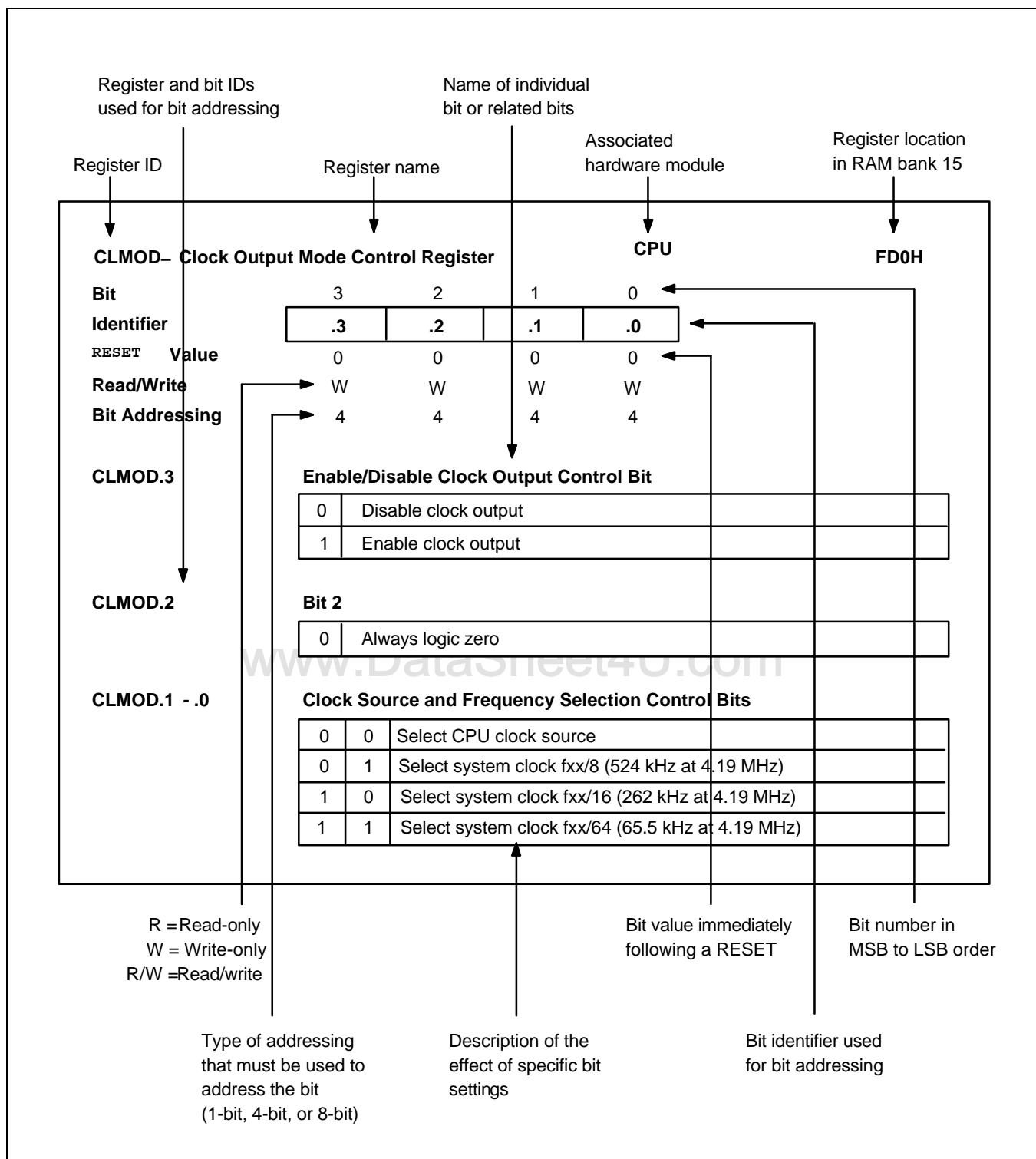

Figure 4-1. Register Description Format

**BMOD** — Basic Timer Mode Register

F85H

Bit	3	2	1	0
Identifier	<b>.3</b>	<b>.2</b>	<b>.1</b>	<b>.0</b>
RESET Value	0	0	0	0
Read/Write	W	W	W	W
Bit Addressing	1/4	4	4	4

**.3 Basic Timer Restart Bit**

1	Restart basic timer, then clear IRQB flag, BCNT and BMOD.3 to logic zero
---	--

**.2–.0 Input Clock Frequency and Signal Stabilization Interval Control Bits**

0	0	0	Input clock frequency: Signal stabilization interval:	$f_{xx} / 2^{12}$ (1.02 kHz) $2^{20} / f_{xx}$ (250 ms)
0	1	1	Input clock frequency: Signal stabilization interval:	$f_{xx} / 2^9$ (8.18 kHz) $2^{17} / f_{xx}$ (31.3 ms)
1	0	1	Input clock frequency: Signal stabilization interval:	$f_{xx} / 2^7$ (32.7 kHz) $2^{15} / f_{xx}$ (7.82 ms)
1	1	1	Input clock frequency: Signal stabilization interval:	$f_{xx} / 2^5$ (131 kHz) $2^{13} / f_{xx}$ (1.95 ms)

**NOTES:**

- Signal stabilization interval is the time required to stabilize clock signal oscillation after stop mode is terminated by an interrupt. The stabilization interval can also be interpreted as "Interrupt Interval Time".
- When a RESET occurs, the oscillation stabilization time is 31.3 ms ( $2^{17}/f_{xx}$ ) at 4.19 MHz.
- 'fxx' is the system clock rate given a clock frequency of 4.19 MHz.



**CLMOD** — Clock Output Mode Register

FD0H

Bit	3	2	1	0
Identifier	.3	"0"	.1	.0
RESET Value	0	0	0	0
Read/Write	W	W	W	W
Bit Addressing	4	4	4	4

**.3 Enable/Disable Clock Output Control Bit**

0	Disable clock output
1	Enable clock output

**.2 Bit 2**

0	Always logic zero
---	-------------------

**.1–.0 Clock Source and Frequency Selection Control Bits**

0	0	Select CPU clock source fx/4, fx/8, fx/64 or fxt/4 (1.05 MHz, 524 kHz, 65.5 kHz or 8.192KHz)
0	1	Select system clock fxx/8 (524 kHz)
1	0	Select system clock fxx/16 (262 kHz)
1	1	Select system clock fxx/64 (65.5 kHz)

**NOTE:** 'fxx' and 'fx' is the system clock and the main clock respectively, given a clock frequency of 4.19 MHz.  
'fxt' is the sub clock, given a clock frequency of 32.768KHz.

**IE0, 1, IRQ0, 1 — INT0, 1 Interrupt Enable/Request Flags****FBEH**

<b>Bit</b>	3	2	1	0
<b>Identifier</b>	<b>IE1</b>	<b>IRQ1</b>	<b>IE0</b>	<b>IRQ0</b>
<b>RESET Value</b>	0	0	0	0
<b>Read/Write</b>	R/W	R/W	R/W	R/W
<b>Bit Addressing</b>	1/4	1/4	1/4	1/4

**IE1****INT1 Interrupt Enable Flag**

0	Disable interrupt requests at the INT1 pin
1	Enable interrupt requests at the INT1 pin

**IRQ1****INT1 Interrupt Request Flag**

–	Generate INT1 interrupt (This bit is set and cleared by hardware when rising or falling edge detected at INT1 pin.)
---	---

**IE0****INT0 Interrupt Enable Flag**

0	Disable interrupt requests at the INT0 pin
1	Enable interrupt requests at the INT0 pin

**IRQ0****INT0 Interrupt Request Flag**

–	Generate INT0 interrupt (This bit is set and cleared automatically by hardware when rising or falling edge detected at INT0 pin.)
---	---

**IE2, IRQ2 — INT2 Interrupt Enable/Request Flags****FBFH**

Bit	3	2	1	0
Identifier	"0"	"0"	IE2	IRQ2
RESET Value	0	0	0	0
Read/Write	R/W	R/W	R/W	R/W
Bit Addressing	1/4	1/4	1/4	1/4

**.3–2****Bits 3–2**

0	Always logic zero
---	-------------------

**IE2****INT2 Interrupt Enable Flag**

0	Disable INT2 interrupt requests at the INT2 pin
1	Enable INT2 interrupt requests at the INT2 pin

**IRQ2****INT2 Interrupt Request Flag**

–	Generate INT2 quasi-interrupt (This bit is set and is <u>not</u> cleared automatically by hardware when a rising or falling edge is detected at INT2. Since INT2 is a quasi-interrupt, IRQ2 flag must be cleared by software.)
---	--

www.DataSheet4U.com



ELECTRONICS

**IEB, IRQB — INTB Interrupt Enable/Request Flags****FB8H**

Bit	3	2	1	0
Identifier	"0"	"0"	IEB	IRQB
RESET Value	0	0	0	0
Read/Write	R/W	R/W	R/W	R/W
Bit Addressing	1/4	1/4	1/4	1/4

**.3–2****Bits 3–2**

0	Always logic zero
---	-------------------

**IEB****INTB Interrupt Enable Flag**

0	Disable INTB interrupt requests
1	Enable INTB interrupt requests

**IRQB****INTB Interrupt Request Flag**

–	Generate INTB interrupt (This bit is set and cleared automatically by hardware when reference interval signal received from basic timer.)
---	---

www.DataSheet4U.com

**IETO, IRQT0 — INTT0 Interrupt Enable/Request Flags****FBCH**

Bit	3	2	1	0
Identifier	"0"	"0"	IETO	IRQT0
RESET Value	0	0	0	0
Read/Write	R/W	R/W	R/W	R/W
Bit Addressing	1/4	1/4	1/4	1/4

**.3–2****Bits 3–2**

0	Always logic zero
---	-------------------

**IETO****INTT0 Interrupt Enable Flag**

0	Disable INTT0 interrupt requests
1	Enable INTT0 interrupt requests

**IRQT0****INTT0 Interrupt Request Flag**

–	Generate INTT0 interrupt (This bit is set and cleared automatically by hardware when contents of TCNT0 and TREF0 registers match.)
---	--

www.DataSheet4U.com

**IEW, IRQW — INTW Interrupt Enable/Request Flags****FBAH**

Bit	3	2	1	0
Identifier	"0"	"0"	IEW	IRQW
RESET Value	0	0	0	0
Read/Write	R/W	R/W	R/W	R/W
Bit Addressing	1/4	1/4	1/4	1/4

**.3–2****Bits 3–2**

0	Always logic zero
---	-------------------

**IEW****INTW Interrupt Enable Flag**

0	Disable INTW interrupt requests
1	Enable INTW interrupt requests

**IRQW****INTW Interrupt Request Flag**

–	Generate INTW interrupt (This bit is set when the timer interval is set to 0.5 seconds or 3.91 milliseconds.)
---	---

**NOTE:** Since INTW is a quasi-interrupt, the IRQW flag must be cleared by software.

www.DataSheet4U.com

**IMOD0** — External Interrupt 0 (INT0) Mode Register

FB4H

<b>Bit</b>	3	2	1	0
<b>Identifier</b>	<b>.3</b>	<b>"0"</b>	<b>.1</b>	<b>.0</b>
<b>RESET Value</b>	0	0	0	0
<b>Read/Write</b>	W	W	W	W
<b>Bit Addressing</b>	4	4	4	4

**.3****Interrupt Sampling Clock Selection Bit**

0	Select CPU clock as a sampling clock
1	Select sampling clock frequency of the selected system clock (f <sub>xx</sub> /64)

**.2****Bit 2**

0	Always logic zero
---	-------------------

**.1–0****External Interrupt Mode Control Bits**

0	0	Interrupt requests are triggered by a rising signal edge
0	1	Interrupt requests are triggered by a falling signal edge
1	0	Interrupt requests are triggered by both rising and falling signal edges
1	1	Interrupt request flag (IRQ0) cannot be set to logic one

**IMOD1** — External Interrupt 1 (INT1) Mode Register

FB5H

Bit	3	2	1	0
Identifier	"0"	"0"	"0"	<b>IMOD1.0</b>
RESET Value	0	0	0	0
Read/Write	W	W	W	W
Bit Addressing	4	4	4	4

.3–1

**Bits 3–1**

0	Always logic zero
---	-------------------

.0

**External Interrupt 1 Edge Detection Control Bit**

0	Rising edge detection
1	Falling edge detection

www.DataSheet4U.com



**IMOD2** — External Interrupt 2 (INT2) Mode Register

FB6H

Bit	3	2	1	0
Identifier	"0"	"0"	IMOD2.1	IMOD2.0
RESET Value	0	0	0	0
Read/Write	W	W	W	W
Bit Addressing	4	4	4	4

.3–2

**Bits 3–2**

0	Always logic zero
---	-------------------

.1–0

**External Interrupt 2 Edge Detection Selection Bit**

0	0	Select rising edge at INT2 pin
0	1	Reserved
1	0	Select falling edge at KS2–KS3
1	1	Select falling edge at KS0–KS3

www.DataSheet4U.com

**IPR — Interrupt Priority Register****FB2H**

<b>Bit</b>	3	2	1	0
<b>Identifier</b>	<b>IME</b>	<b>.2</b>	<b>.1</b>	<b>.0</b>
<b>RESET Value</b>	0	0	0	0
<b>Read/Write</b>	W	W	W	W
<b>Bit Addressing</b>	1/4	4	4	4

**IME****Interrupt Master Enable Bit**

0	Disable all interrupt processing
1	Enable processing for all interrupt service requests

**.2–.0****Interrupt Priority Assignment Bits**

0	0	0	Normal interrupt handling according to default priority settings
0	0	1	Process INTB interrupt at highest priority
0	1	0	Process INT0 interrupt at highest priority
0	1	1	Process INT1 interrupt at highest priority
1	0	0	Reserved
1	0	1	Process INTT0 interrupt at highest priority

**LCON** — LCD Output Control Register

F8EH

Bit	3	2	1	0
Identifier	"0"	.2	"0"	.0
RESET Value	0	0	0	0
Read/Write	W	W	W	W
Bit Addressing	4	4	4	4

**.3 LCD Bias Selection Bit**

0	This bit is used for internal testing only; always logic zero.
---	--

**.2 LCD Clock Output Disable/Enable Bit**

0	Disable LCDCK and LCDSY signal outputs.
1	Enable LCDCK and LCDSY signal outputs.

**.1 Bit 1**

0	Always logic zero
---	-------------------

**.0 LCD Display Control Bit**

0	LCD output low, turns display off: cut off current to dividing resistor, and output port 8 latch contents.
1	If LMOD.3 = "0": turn display off; output port 8 latch contents; If LMOD.3 = "1": COM and SEG output in display mode; LCD display on.

**NOTES:**

1. You can manipulate LCON.0, when you try to turn ON/OFF LCD display internally. If you want to control LCD ON/OFF or LCD contrast externally, you should set the LCON.0 to "0". refer to chapter 12, if you need more information.
2. To select the LCD bias, you must properly configure both LCON.0 and the external LCD bias circuit connection.
3. The LCON.3 register must be set to "0".

**LMOD** — LCD Mode Register

F8DH, F8CH

Bit	7	6	5	4	3	2	1	0
Identifier	.7	.6	.5	.4	.3	.2	.1	.0
RESET Value	0	0	0	0	0	0	0	0
Read/Write	W	W	W	W	W	W	W	W
Bit Addressing	8	8	8	8	1/8	8	8	8

.7–.6

**LCD Output Segment and Pin Configuration Bits**

0	0	Segments 24–27; and 28–31
0	1	Segment 24–27; 1-bit output at P8.4–P8.7
1	0	Segment 28–31; 1-bit output at P8.0–P8.3
1	1	1-bit output only at P8.0–P8.3, and P8.4–P8.7

.5–.4

**LCD Clock (LCDCK) Frequency Selection Bits**

0	0	$f_w/2^9 = 64$ Hz
0	1	$f_w/2^8 = 128$ Hz
1	0	$f_w/2^7 = 256$ Hz
1	1	$f_w/2^6 = 512$ Hz

.3–.0

**Duty and Bias Selection for LCD Display**

0	–	–	–	LCD display off
1	0	0	0	1/4 duty, 1/3 bias
1	0	0	1	1/3 duty, 1/3 bias
1	0	1	0	1/2 duty, 1/2 bias
1	0	1	1	1/3 duty, 1/2 bias
1	1	0	0	Static

**NOTE:** Watch timer frequency( $f_w$ ) is assumed to be 32.768KHz.

**PCON** — Power Control Register

FB3H

<b>Bit</b>	3	2	1	0
<b>Identifier</b>	<b>.3</b>	<b>.2</b>	<b>.1</b>	<b>.0</b>
<b>RESET Value</b>	0	0	0	0
<b>Read/Write</b>	W	W	W	W
<b>Bit Addressing</b>	4	4	4	4

**.3–2****CPU Operating Mode Control Bits**

0	0	Enable normal CPU operating mode
0	1	Initiate idle power-down mode
1	0	Initiate stop power-down mode

**.1–0****CPU Clock Frequency Selection Bits**

0	0	If SCMOD.0 = "0", fx/64; if SCMOD.0 = "1", fxt/4
1	0	If SCMOD.0 = "0", fx/8; if SCMOD.0 = "1", fxt/4
1	1	If SCMOD.0 = "0", fx/4; if SCMOD.0 = "1", fxt/4

**NOTE:** 'fx' is the main system clock; 'fxt' is the subsystem clock.

www.DataSheet4U.com

**PMG1 — Port I/O Mode Flags (Group 1: Ports 3 and 6)****FE9H, FE8H**

Bit	7	6	5	4	3	2	1	0
Identifier	<b>PM6.3</b>	<b>PM6.2</b>	<b>PM6.1</b>	<b>PM6.0</b>	<b>PM3.3</b>	<b>PM3.2</b>	<b>PM3.1</b>	<b>PM3.0</b>
RESET Value	0	0	0	0	0	0	0	0
Read/Write	W	W	W	W	W	W	W	W
Bit Addressing	8	8	8	8	8	8	8	8

**PM6.3 P6.3 I/O Mode selection Flag**

0	Set P6.3 to input mode
1	Set P6.3 to output mode

**PM6.2 P6.2 I/O Mode Selection Flag**

0	Set P6.2 to input mode
1	Set P6.2 to output mode

**PM6.1 P6.1 I/O Mode Selection Flag**

0	Set P6.1 to input mode
1	Set P6.1 to output mode

**PM6.0 P6.0 I/O Mode Selection Flag**

0	Set P6.0 to input mode
1	Set P6.0 to output mode

**PM3.3 P3.3 I/O Mode Selection Flag**

0	Set P3.3 to input mode
1	Set P3.3 to output mode

**PM3.2 P3.2 I/O Mode Selection Flag**

0	Set P3.2 to input mode
1	Set P3.2 to output mode

**PM3.1 P3.1 I/O Mode Selection Flag**

0	Set P3.1 to input mode
1	Set P3.1 to output mode

**PM3.0 P3.0 I/O Mode Selection Flag**

0	Set P3.0 to input mode
1	Set P3.0 to output mode

**PMG2 — Port I/O Mode Flags (Group 2: Port 2)**

FEDH, FECH

Bit	7	6	5	4	3	2	1	0
Identifier	"0"	"0"	"0"	"0"	"0"	PM2	"0"	"0"
RESET Value	0	0	0	0	0	0	0	0
Read/Write	W	W	W	W	W	W	W	W
Bit Addressing	8	8	8	8	8	8	8	8

.7–3

**Bits 7–3**

0	Always logic zero
---	-------------------

PM2

**P2 I/O Mode Selection Flag**

0	Set P2 to input mode
1	Set P2 to output mode

.1–0

**Bits 1–0**

0	Always logic zero
---	-------------------

www.DataSheet4U.com

**PSW — Program Status Word****FB1H, FB0H**

Bit	7	6	5	4	3	2	1	0
Identifier	<b>C</b>	<b>SC2</b>	<b>SC1</b>	<b>SC0</b>	<b>IS1</b>	<b>IS0</b>	<b>EMB</b>	<b>ERB</b>
RESET Value	(1)	0	0	0	0	0	0	0
Read/Write	R/W	R	R	R	R/W	R/W	R/W	R/W
Bit Addressing	(2)	8	8	8	1/4	1/4	1	1

**C Carry Flag**

0	No overflow or borrow condition exists
1	An overflow or borrow condition exists

**SC2–SC0 Skip Condition Flags**

0	No skip condition exists; no direct manipulation of these bits is allowed
1	A skip condition exists; no direct manipulation of these bits is allowed

**IS1, IS0 Interrupt Status Flags**

0	0	Service all interrupt requests
0	1	Service only the high-priority interrupt(s) as determined in the interrupt priority register (IPR)
1	0	Do not service any more interrupt requests
1	1	Undefined

**EMB Enable Data Memory Bank Flag**

0	Restrict program access to data memory to bank 15 (F80H–FFFH) and to the locations 000H–07FH in the bank 0 only
1	Enable full access to data memory banks 0, 1, 2, and 15

**ERB Enable Register Bank Flag**

0	Select register bank 0 as working register area
1	Select register banks 0, 1, 2, or 3 as working register area in accordance with the select register bank (SRB) instruction operand

**NOTES:**

1. The value of the carry flag after a RESET occurs during normal operation is undefined. If a RESET occurs during power-down mode (IDLE or STOP), the current value of the carry flag is retained.
2. The carry flag can only be addressed by a specific set of 1-bit manipulation instructions. See Section 2 for detailed information.



**PUMOD — Pull-Up Resistor Mode Register**

FDDH, FDCH

Bit	7	6	5	4	3	2	1	0
Identifier	"0"	PUR6	"0"	"0"	PUR3	PUR2	PUR1	"0"
RESET Value	0	0	0	0	0	0	0	0
Read/Write	W	W	W	W	W	W	W	W
Bit Addressing	8	8	8	8	8	8	8	8

.7

**Bit 7**

0	Always logic zero
---	-------------------

PUR6

**Connect/Disconnect Port 6 Pull-Up Resistor Control Bit**

0	Disconnect port 6 pull-up resistor
1	Connect port 6 pull-up resistor

.5–4

**Bits 5–4**

0	Always logic zero
---	-------------------

PUR3

**Connect/Disconnect Port 3 Pull-Up Resistor Control Bit**

0	Disconnect port 3 pull-up resistor
1	Connect port 3 pull-up resistor

PUR2

**Connect/Disconnect Port 2 Pull-Up Resistor Control Bit**

0	Disconnect port 2 pull-up resistor
1	Connect port 2 pull-up resistor

PUR1

**Connect/Disconnect Port 1 Pull-Up Resistor Control Bit**

0	Disconnect port 1 pull-up resistor
1	Connect port 1 pull-up resistor

.0

**Bit 0**

0	Always logic zero
---	-------------------

**NOTE:** Pull-up resistors for all I/O ports are automatically disabled when they are configured to output mode.

**SCMOD** — System Clock Mode Control Register

FB7H

Bit	3	2	1	0
Identifier	<b>.3</b>	<b>.2</b>	<b>"0"</b>	<b>.0</b>
RESET Value	0	0	0	0
Read/Write	W	W	W	W
Bit Addressing	1	1	1	1

**.3, .2 and .0****CPU Clock Selection and Main System Clock Oscillation Control Bits**

0	0	0	Select main system clock (fx); enable main system clock
0	1	0	Select main system clock (fx); disable sub system clock
0	0	1	Select sub system clock (fxt); enable main system clock
1	0	1	Select sub system clock (fxt); disable main system clock

**.1****Bit 1**

0	Always logic zero
---	-------------------

**NOTE:** SCMOD bits 3 and 0 cannot be modified simultaneously by a 4-bit instruction; they can only be modified by separate 1-bit instructions.

www.DataSheet4U.com

**TMOD0 — Timer/Counter 0 Mode Register****F91H, F90H**

Bit	7	6	5	4	3	2	1	0
Identifier	"0"	.6	.5	.4	.3	.2	"0"	"0"
RESET Value	0	0	0	0	0	0	0	0
Read/Write	W	W	W	W	W	W	W	W
Bit Addressing	8	8	8	8	1/8	8	8	8

**.7****Bit 7**

0	Always logic zero
---	-------------------

**.6–4****Timer/Counter 0 Input Clock Selection Bits**

0	0	0	External clock input at TCL0 pin on rising edge
0	0	1	External clock input at TCL0 pin on falling edge
1	0	0	Select clock: $f_{xx}/2^{10}$ (4.09 kHz at 4.19 MHz)
1	0	1	Select clock: $f_{xx}/2^8$ (16.4 kHz at 4.19 MHz)
1	1	0	Select clock: $f_{xx}/2^6$ (65.5 kHz at 4.19 MHz)
1	1	1	Select clock: $f_{xx}/2^4$ (262 kHz at 4.19 MHz)

**.3****Clear Counter and Resume Counting Control Bit**

1	Clear TCNT0, IRQT0, and TOL0 and resume counting immediately (This bit is cleared automatically when counting starts.)
---	--

**.2****Enable/Disable Timer/Counter 0 Bit**

0	Disable timer/counter 0; retain TCNT0 contents
1	Enable timer/counter 0

**.1–0****Bits 1–0**

0	Always logic zero
---	-------------------

**TOE** — Timer Output Enable Flag Register

F92H

Bit	3	2	1	0
Identifier	"u"	<b>TOE0</b>	"u"	"u"
RESET Value	–	0	0	–
Read/Write	–	R/W	–	–
Bit Addressing	–	1	–	–

.3

**Bit3**

u	Unknown value
---	---------------

TOE0

**Timer/Counter 0 Output Enable Flag**

0	Disable timer/counter 0 output at the TCLO0 pin
1	Enable timer/counter 0 output at the TCLO0 pin

.1–0

**Bits 1–0**

u	Unknown value
---	---------------

**NOTES:**

1. "u" means that the bit is unknown.

www.DataSheet4U.com

**WDFLAG** — Watchdog Timer Counter Clear Flag Register

F9AH

Bit	3	2	1	0
Identifier	WDTCF	"0"	"0"	"0"
RESET Value	0	0	0	0
Read/Write	W	W	W	W
Bit Addressing	1/4	1/4	1/4	1/4

**WDTCF****Watchdog Timer Counter Clear Flag**

1	Clears the watchdog timer counter
---	-----------------------------------

**.2–0****Bits 2–0**

0	Always logic zero
---	-------------------

**NOTE:** After watchdog timer is cleared by writing "1", this bit is cleared to "0" automatically. Instruction that clear the watchdog timer ("BITS WDTCF") should be executed at proper points in a program within a given period. If not executed within a given period and watchdog timer overflows, RESET signal is generated and system is restarted with reset status.

www.DataSheet4U.com

**WDMOD — Watchdog Timer Mode Register****F99H, F98H**

Bit	7	6	5	4	3	2	1	0
Identifier	<b>.7</b>	<b>.6</b>	<b>.5</b>	<b>.4</b>	<b>.3</b>	<b>.2</b>	<b>.1</b>	<b>.0</b>
RESET Value	1	0	1	0	0	1	0	1
Read/Write	W	W	W	W	W	W	W	W
Bit Addressing	8	8	8	8	8	8	8	8

**WDMOD****Watchdog Timer Enable/Disable Control**

5AH	Disable watchdog timer function
Any other value	Enable watchdog timer function

www.DataSheet4U.com

**WMOD — Watch Timer Mode Register****F89H, F88H**

Bit	7	6	5	4	3	2	1	0
Identifier	<b>.7</b>	<b>"0"</b>	<b>.5</b>	<b>.4</b>	<b>.3</b>	<b>.2</b>	<b>.1</b>	<b>.0</b>
RESET Value	0	0	0	0	(note)	0	0	0
Read/Write	W	W	W	W	R	W	W	W
Bit Addressing	8	8	8	8	1	8	8	8

**.7 Enable/Disable Buzzer Output Bit**

0	Disable buzzer (BUZ) signal output
1	Enable buzzer (BUZ) signal output

**.6 Bit 6**

0	Always logic zero
---	-------------------

**.5–.4 Output Buzzer Frequency Selection Bits**

0	0	2 kHz buzzer (BUZ) signal output
0	1	4 kHz buzzer (BUZ) signal output
1	0	8 kHz buzzer (BUZ) signal output
1	1	16 kHz buzzer (BUZ) signal output

**.3 XT<sub>in</sub> Input Level Control Bit**

0	Input level to XT <sub>in</sub> pin is low; 1-bit read-only addressable for tests
1	Input level to XT <sub>in</sub> pin is high; 1-bit read-only addressable for tests

**.2 Enable/Disable Watch Timer Bit**

0	Disable watch timer and clear frequency dividing circuits
1	Enable watch timer

**.1 Watch Timer Speed Control Bit**

0	Normal speed; set IRQW to 0.5 seconds
1	High-speed operation; set IRQW to 3.91 ms

**.0 Watch Timer Clock Selection Bit**

0	Select system clock (f <sub>xx</sub> )/128 as the watch timer clock
1	Select a subsystem clock as the watch timer clock

**NOTE:** RESET sets WMOD.3 to the current input level of the subsystem clock, XT<sub>in</sub>. If the input level is high, WMOD.3 is set to logic one; if low, WMOD.3 is cleared to zero along with all the other bits in the WMOD register.

# 5 SAM47 INSTRUCTION SET

## OVERVIEW

The SAM47 instruction set includes 1-bit, 4-bit, and 8-bit instructions for data manipulation, logical and arithmetic operations, program control, and CPU control. I/O instructions for peripheral hardware devices are flexible and easy to use. Symbolic hardware names can be substituted as the instruction operand in place of the actual address. Other important features of the SAM47 instruction set include:

- 1-byte referencing of long instructions (REF instruction)
- Redundant instruction reduction (string effect)
- Skip feature for ADC and SBC instructions

Instruction operands conform to the operand format defined for each instruction. Several instructions have multiple operand formats.

Predefined values or labels can be used as instruction operands when addressing immediate data. Many of the symbols for specific registers and flags may also be substituted as labels for operations such DA, mema, memb, b, and so on. Using instruction labels can greatly simplify program writing and debugging tasks.

## INSTRUCTION SET FEATURES

In this Chapter, the following SAM47 instruction set features are described in detail:

- Instruction reference area
- Instruction redundancy reduction
- Flexible bit manipulation
- ADC and SBC instruction skip condition

### NOTE

The ROM size accessed by instruction may change for KS57C2302 and KS57C2304.



### Instruction Reference Area

Using the 1-byte REF (Reference) instruction, you can reference instructions stored in addresses 0020H–007FH of program memory (the REF instruction look-up table). The location referenced by REF may contain either two 1-byte instructions or a single 2-byte instruction. The starting address of the instruction being referenced must always be an even number.

3-byte instructions such as JP or CALL may also be referenced using REF. To reference these 3-byte instructions, the 2-byte pseudo commands TJP and TCALL must be written in the reference.

The PC is not incremented when a REF instruction is executed. After it executes, the program's instruction execution sequence resumes at the address immediately following the REF instruction. By using REF instructions to execute instructions larger than one byte, as well as branches and subroutines, you can reduce the program size. To summarize, the REF instruction can be used in three ways:

- Using the 1-byte REF instruction to execute one 2-byte or two 1-byte instructions;
- Branching to any location by referencing a branch address that is stored in the look-up table;
- Calling subroutines at any location by referencing a call address that is stored in the look-up table.

If necessary, a REF instruction can be circumvented by means of a skip operation prior to the REF in the execution sequence. In addition, the instruction immediately following a REF can also be skipped by using an appropriate reference instruction or instructions.

Two-byte instructions can be referenced by using a REF instruction. (An exception is XCH A,DA\*)  
If the MSB value of the first 1-byte instruction in the reference area is "0", the instruction cannot be referenced by a REF instruction. Therefore, if you use REF to reference two 1-byte instructions stored in the reference area, specific combinations must be used for the first and second 1-byte instruction. These combinations are described in Table5-1.

**Table 5-1. Valid 1-Byte Instruction Combinations for REF Look-Ups**

First 1-Byte Instruction		Second 1-Byte Instruction	
Instruction	Operand	Instruction	Operand
LD	A,#im	INCS*	R
		INCS	RRb
		DECS*	R
LD	A,@RRq	INCS*	R
		INCS	RRb
		DECS*	R
LD	@HL,A	INCS*	R
		INCS	RRb
		DECS*	R

**NOTE:** If the MSB value of the first one-byte binary code in instruction is "0", the instruction cannot be referenced by a REF instruction.

### Reducing Instruction Redundancy

When redundant instructions such as LD A,#im and LD EA,#imm are used consecutively in a program sequence, only the first instruction is executed. The redundant instructions which follow are ignored, that is, they are handled like a NOP instruction. When LD HL,#imm instructions are used consecutively, redundant instructions are also ignored.

In the following example, only the 'LD A, #im' instruction will be executed. The 8-bit load instruction which follows it is interpreted as redundant and is ignored:

```
LD      A,#im          ; Load 4-bit immediate data (#im) to accumulator
LD      EA,#imm        ; Load 8-bit immediate data (#imm) to extended
                          ; accumulator
```

In this example, the statements 'LD A,#2H' and 'LD A,#3H' are ignored:

```
BITR    EMB
LD      A,#1H          ; Execute instruction
LD      A,#2H          ; Ignore, redundant instruction
LD      A,#3H          ; Ignore, redundant instruction
LD      23H,A         ; Execute instruction, 023H ← #1H
```

If consecutive LD HL, #imm instructions (load 8-bit immediate data to the 8-bit memory pointer pair, HL) are detected, only the first LD is executed and the LDs which immediately follow are ignored. For example,

```
LD      HL,#10H        ; HL ← 10H
LD      HL,#20H        ; Ignore, redundant instruction
LD      A,#3H          ; A ← 3H
LD      EA,#35H        ; Ignore, redundant instruction
LD      @HL,A         ; (10H) ← 3H
```

If an instruction reference with a REF instruction has a redundancy effect, the following conditions apply:

- If the instruction *preceding* the REF has a redundancy effect, this effect is canceled and the referenced instruction is not skipped.
- If the instruction *following* the REF has a redundancy effect, the instruction following the REF is skipped.

### PROGRAMMING TIP — Example of the Instruction Redundancy Effect

```
ABC     ORG      0020H
        LD      EA,#30H          ; Stored in REF instruction reference area
        ORG      0080H
        .
        .
        .
        LD      EA,#40H          ; Redundancy effect is encountered
        REF     ABC              ; No skip (EA ← #30H)
        .
        .
        .
        REF     ABC              ; EA ← #30H
        LD      EA,#50H          ; Skip
```

### Flexible Bit Manipulation

In addition to normal bit manipulation instructions like set and clear, the SAM47 instruction set can also perform bit tests, bit transfers, and bit Boolean operations. Bits can also be addressed and manipulated by special bit addressing modes. Three types of bit addressing are supported:

- mema.b
- memb.@L
- @H+DA.b

The parameters of these bit addressing modes are described in more detail in Table 5-2.

**Table 5-2. Bit Addressing Modes and Parameters**

Addressing Mode	Addressable Peripherals	Address Range
mema.b	ERB, EMB, IS1, IS0, IEx, IRQx	FB0H–FBFH
	Ports 1, 2, 3, 6	FF0H–FFFH
memb.@L	Ports 1, 2, 3, 6, and BSC	FC0H–FFFH
@H+DA.b	All bit-manipulable peripheral hardware	All bits of the memory bank specified by EMB and SMB that are bit-manipulable

### Instructions Which Have Skip Conditions

The following instructions have a skip function when an overflow or borrow occurs:

XCHI	INCS
XCHD	DECS
LDI	ADS
LDD	SBS

If there is an overflow or borrow from the result of an increment or decrement, a skip signal is generated and a skip is executed. However, the carry flag value is unaffected.

The instructions BTST, BTSF, and CPSE also generate a skip signal and execute a skip when they meet a skip condition, and the carry flag value is also unaffected.

### Instructions Which Affect the Carry Flag

The only instructions which do not generate a skip signal, but which do affect the carry flag are as follows:

ADC	LDB	C,(operand)
SBC	BAND	C,(operand)
SCF	BOR	C,(operand)
RCF	BXOR	C,(operand)
CCF		

### ADC and SBC Instruction Skip Conditions

The instructions 'ADC A,@HL' and 'SBC A,@HL' can generate a skip signal, and set or clear the carry flag, when they are executed in combination with the instruction 'ADS A,#im'.

If an 'ADS A,#im' instruction immediately follows an 'ADC A,@HL' or 'SBC A,@HL' instruction in a program sequence, the ADS instruction does not skip the instruction following ADS, even if it has a skip function. If, however, an 'ADC A,@HL' or 'SBC A,@HL' instruction is immediately followed by an 'ADS A,#im' instruction, the ADC (or SBC) skips on overflow (or if there is no borrow) to the instruction immediately following the ADS, and program execution continues. Table 5-3 contains additional information and examples of the 'ADC A,@HL' and 'SBC A,@HL' skip feature.

**Table 5-3. Skip Conditions for ADC and SBC Instructions**

Sample Instruction Sequences		If the result of instruction 1 is:	Then, the execution sequence is:	Reason
ADC A,@HL	1	Overflow	1, 3, 4	ADS cannot skip instruction 3, even if it has a skip function.
ADS A,#im	2	No overflow	1, 2, 3, 4	
xxx	3			
xxx	4			
SBC A,@HL	1	Borrow	1, 2, 3, 4	ADS cannot skip instruction 3, even if it has a skip function.
ADS A,#im	2	No borrow	1, 3, 4	
xxx	3			
xxx	4			

www.DataSheet4U.com

## SYMBOLS and CONVENTIONS

Table 5-4. Data Type Symbols

Symbol	Data Type
d	Immediate data
a	Address data
b	Bit data
r	Register data
f	Flag data
i	Indirect addressing data
t	memc × 0.5 immediate data

Table 5-5. Register Identifiers

Full Register Name	ID
4-bit accumulator	A
4-bit working registers	E, L, H, X, W, Z, Y
8-bit extended accumulator	EA
8-bit memory pointer	HL
8-bit working registers	WX, YZ, WL
Select register bank 'n'	SRB n
Select memory bank 'n'	SMB n
Carry flag	C
Program status word	PSW
Port 'n'	Pn
'm'-th bit of port 'n'	Pn.m
Interrupt priority register	IPR
Enable memory bank flag	EMB
Enable register bank flag	ERB

Table 5-6. Instruction Operand Notation

Symbol	Definition
DA	Direct address
@	Indirect address prefix
src	Source operand
dst	Destination operand
(R)	Contents of register R
.b	Bit location
im	4-bit immediate data (number)
imm	8-bit immediate data (number)
#	Immediate data prefix
ADR	000H–1FFFH immediate address
ADRn	'n' bit address
R	A, E, L, H, X, W, Z, Y
Ra	E, L, H, X, W, Z, Y
RR	EA, HL, WX, YZ
RRa	HL, WX, WL
RRb	HL, WX, YZ
RRc	WX, WL
mema	FB0H–FBFH, FF0H–FFFH
memb	FC0H–FFFH
memc	Code direct addressing: 0020H–007FH
SB	Select bank register (8 bits)
XOR	Logical exclusive-OR
OR	Logical OR
AND	Logical AND
[(RR)]	Contents addressed by RR

## OPCODE DEFINITIONS

Table 5-7. Opcode Definitions (Direct)

Register	r2	r1	r0
A	0	0	0
E	0	0	1
L	0	1	0
H	0	1	1
X	1	0	0
W	1	0	1
Z	1	1	0
Y	1	1	1
EA	0	0	0
HL	0	1	0
WX	1	0	0
YZ	1	1	0

r = Immediate data for register

Table 5-8. Opcode Definitions (Indirect)

Register	i2	i1	i0
@HL	1	0	1
@WX	1	1	0
@WL	1	1	1

i = Immediate data for indirect addressing

## CALCULATING ADDITIONAL MACHINE CYCLES FOR SKIPS

A machine cycle is defined as one cycle of the selected CPU clock. Three different clock rates can be selected using the PCON register.

In this document, the letter 'S' is used in tables when describing the number of additional machine cycles required for an instruction to execute, given that the instruction has a skip function ('S' = skip). The addition number of machine cycles that will be required to perform the skip usually depends on the size of the instruction being skipped — whether it is a 1-byte, 2-byte, or 3-byte instruction. A skip is also executed for SMB and SRB instructions.

The values in additional machine cycles for 'S' for the three cases in which skip conditions occur are as follows:

- |  |              |
|--|--------------|
| Case 1: No skip                              | S = 0 cycles |
| Case 2: Skip is 1-byte or 2-byte instruction | S = 1 cycle  |
| Case 3: Skip is 3-byte instruction           | S = 2 cycles |

**NOTE:** REF instructions are skipped in one machine cycle.

## HIGH-LEVEL SUMMARY

This Chapter contains a high-level summary of the SAM47 instruction set in table format. The tables are designed to familiarize you with the range of instructions that are available in each instruction category.

These tables are a useful quick-reference resource when writing application programs.

If you are reading this user's manual for the first time, however, you may want to scan this detailed information briefly, and then return to it later on. The following information is provided for each instruction:

- Instruction name
- Operand(s)
- Brief operation description
- Number of bytes of the instruction and operand(s)
- Number of machine cycles required to execute the instruction

The tables in this Chapter are arranged according to the following instruction categories:

- CPU control instructions
- Program control instructions
- Data transfer instructions
- Logic instructions
- Arithmetic instructions
- Bit manipulation instructions

www.DataSheet4U.com

Table 5-9. CPU Control Instructions — High-Level Summary

Name	Operand	Operation Description	Bytes	Cycles
SCF		Set carry flag to logic one	1	1
RCF		Reset carry flag to logic zero	1	1
CCF		Complement carry flag	1	1
EI		Enable all interrupts	2	2
DI		Disable all interrupts	2	2
IDLE		Engage CPU idle mode	2	2
STOP		Engage CPU stop mode	2	2
NOP		No operation	1	1
SMB	n	Select memory bank	2	2
SRB	n	Select register bank	2	2
REF	memc	Reference code	1	3
VENTn	EMB (0,1) ERB (0,1) ADR	Load enable memory bank flag (EMB) and the enable register bank flag (ERB) and program counter to vector address, then branch to the corresponding location	2	2

Table 5-10. Program Control Instructions — High-Level Summary

Name	Operand	Operation Description	Bytes	Cycles
CPSE	R,#im	Compare and skip if register equals #im	2	2 + S
	@HL,#im	Compare and skip if indirect data memory equals #im	2	2 + S
	A,R	Compare and skip if A equals R	2	2 + S
	A,@HL	Compare and skip if A equals indirect data memory	1	1 + S
	EA,@HL	Compare and skip if EA equals indirect data memory	2	2 + S
	EA,RR	Compare and skip if EA equals RR	2	2 + S
JP	ADR12	Jump to direct address (12 bits)	3	3
JPS	ADR12	Jump direct in page (12 bits)	2	2
JR	#im	Jump to immediate address	1	2
	@WX	Branch relative to WX register	2	3
	@EA	Branch relative to EA	2	3
CALL	ADR12	Call direct address (12 bits)	3	4
CALLS	ADR11	Call direct address within 2 K (11 bits)	2	3
RET	–	Return from subroutine	1	3
IRET	–	Return from interrupt	1	3
SRET	–	Return from subroutine and skip	1	3 + S



Table 5-11. Data Transfer Instructions — High-Level Summary

Name	Operand	Operation Description	Bytes	Cycles
XCH	A,DA	Exchange A and direct data memory contents	2	2
	A,Ra	Exchange A and register (Ra) contents	1	1
	A,@RRa	Exchange A and indirect data memory	1	1
	EA,DA	Exchange EA and direct data memory contents	2	2
	EA,RRb	Exchange EA and register pair (RRb) contents	2	2
	EA,@HL	Exchange EA and indirect data memory contents	2	2
XCHI	A,@HL	Exchange A and indirect data memory contents; increment contents of register L and skip on carry	1	2 + S
XCHD	A,@HL	Exchange A and indirect data memory contents; decrement contents of register L and skip on carry	1	2 + S
LD	A,#im	Load 4-bit immediate data to A	1	1
	A,@RRa	Load indirect data memory contents to A	1	1
	A,DA	Load direct data memory contents to A	2	2
	A,Ra	Load register contents to A	2	2
	Ra,#im	Load 4-bit immediate data to register	2	2
	RR,#imm	Load 8-bit immediate data to register	2	2
	DA,A	Load contents of A to direct data memory	2	2
	Ra,A	Load contents of A to register	2	2
	EA,@HL	Load indirect data memory contents to EA	2	2
	EA,DA	Load direct data memory contents to EA	2	2
	EA,RRb	Load register contents to EA	2	2
	@HL,A	Load contents of A to indirect data memory	1	1
	DA,EA	Load contents of EA to data memory	2	2
	RRb,EA	Load contents of EA to register	2	2
@HL,EA	Load contents of EA to indirect data memory	2	2	
LDI	A,@HL	Load indirect data memory to A; increment register L contents and skip on carry	1	2 + S
LDD	A,@HL	Load indirect data memory contents to A; decrement register L contents and skip on carry	1	2 + S
LDC	EA,@WX	Load code byte from WX to EA	1	3
	EA,@EA	Load code byte from EA to EA	1	3
RRC	A	Rotate right through carry bit	1	1
PUSH	RR	Push register pair onto stack	1	1
	SB	Push SMB and SRB values onto stack	2	2
POP	RR	Pop to register pair from stack	1	1
	SB	Pop SMB and SRB values from stack	2	2

Table 5-12. Logic Instructions — High-Level Summary

Name	Operand	Operation Description	Bytes	Cycles
AND	A,#im	Logical-AND A immediate data to A	2	2
	A,@HL	Logical-AND A indirect data memory to A	1	1
	EA,RR	Logical-AND register pair (RR) to EA	2	2
	RRb,EA	Logical-AND EA to register pair (RRb)	2	2
OR	A, #im	Logical-OR immediate data to A	2	2
	A, @HL	Logical-OR indirect data memory contents to A	1	1
	EA,RR	Logical-OR double register to EA	2	2
	RRb,EA	Logical-OR EA to double register	2	2
XOR	A,#im	Exclusive-OR immediate data to A	2	2
	A,@HL	Exclusive-OR indirect data memory to A	1	1
	EA,RR	Exclusive-OR register pair (RR) to EA	2	2
	RRb,EA	Exclusive-OR register pair (RRb) to EA	2	2
COM	A	Complement accumulator (A)	2	2

Table 5-13. Arithmetic Instructions — High-Level Summary

Name	Operand	Operation Description	Bytes	Cycles
ADC	A,@HL	Add indirect data memory to A with carry	1	1
	EA,RR	Add register pair (RR) to EA with carry	2	2
	RRb,EA	Add EA to register pair (RRb) with carry	2	2
ADS	A, #im	Add 4-bit immediate data to A and skip on carry	1	1 + S
	EA,#imm	Add 8-bit immediate data to EA and skip on carry	2	2 + S
	A,@HL	Add indirect data memory to A and skip on carry	1	1 + S
	EA,RR	Add register pair (RR) contents to EA and skip on carry	2	2 + S
	RRb,EA	Add EA to register pair (RRb) and skip on carry	2	2 + S
SBC	A,@HL	Subtract indirect data memory from A with carry	1	1
	EA,RR	Subtract register pair (RR) from EA with carry	2	2
	RRb,EA	Subtract EA from register pair (RRb) with carry	2	2
SBS	A,@HL	Subtract indirect data memory from A; skip on borrow	1	1 + S
	EA,RR	Subtract register pair (RR) from EA; skip on borrow	2	2 + S
	RRb,EA	Subtract EA from register pair (RRb); skip on borrow	2	2 + S
DECS	R	Decrement register (R); skip on borrow	1	1 + S
	RR	Decrement register pair (RR); skip on borrow	2	2 + S
INCS	R	Increment register (R); skip on carry	1	1 + S
	DA	Increment direct data memory; skip on carry	2	2 + S
	@HL	Increment indirect data memory; skip on carry	2	2 + S
	RRb	Increment register pair (RRb); skip on carry	1	1 + S

Table 5-14. Bit Manipulation Instructions — High-Level Summary

Name	Operand	Operation Description	Bytes	Cycles
BTST	C	Test specified bit and skip if carry flag is set	1	1 + S
	DA.b	Test specified bit and skip if memory bit is set	2	2 + S
	mema.b			
	memb.@L			
	@H+DA.b			
BTSTZ	DA.b	Test specified memory bit and skip if bit equals "0"	2	2 + S
	mema.b			
	memb.@L			
	@H+DA.b			
BTSTZ	mema.b	Test specified bit; skip and clear if memory bit is set	2	2
	memb.@L			
	@H+DA.b			
BITS	DA.b	Set specified memory bit	2	2
	mema.b			
	memb.@L			
	@H+DA.b			
BITR	DA.b	Clear specified memory bit to logic zero	2	2
	mema.b			
	memb.@L			
	@H+DA.b			
BAND	C,mema.b	Logical-AND carry flag with specified memory bit	2	2
	C,memb.@L			
	C,@H+DA.b			
BOR	C,mema.b	Logical-OR carry with specified memory bit	2	2
	C,memb.@L			
	C,@H+DA.b			
BXOR	C,mema.b	Exclusive-OR carry with specified memory bit	2	2
	C,memb.@L			
	C,@H+DA.b			
LDB	mema.b,C	Load carry bit to a specified memory bit	2	2
	memb.@L,C	Load carry bit to a specified indirect memory bit		
	@H+DA.b,C			
	C,mema.b	Load specified memory bit to carry bit		
	C,memb.@L	Load specified indirect memory bit to carry bit		
	C,@H+DA.b			

## BINARY CODE SUMMARY

This Chapter contains binary code values and operation notation for each instruction in the SAM47 instruction set in an easy-to-read, tabular format. It is intended to be used as a quick-reference source for programmers who are experienced with the SAM47 instruction set. The same binary values and notation are also included in the detailed descriptions of individual instructions later in Chapter 5.

If you are reading this user's manual for the first time, please just scan this very detailed information briefly. Most of the general information you will need to write application programs can be found in the high-level summary tables in the previous Chapter. The following information is provided for each instruction:

- Instruction name
- Operand(s)
- Binary values
- Operation notation

The tables in this Chapter are arranged according to the following instruction categories:

- CPU control instructions
- Program control instructions
- Data transfer instructions
- Logic instructions
- Arithmetic instructions
- Bit manipulation instructions

Table 5-15. CPU Control Instructions — Binary Code Summary

Name	Operand	Binary Code								Operation Notation
SCF		1	1	1	0	0	1	1	1	$C \leftarrow 1$
RCF		1	1	1	0	0	1	1	0	$C \leftarrow 0$
CCF		1	1	0	1	0	1	1	0	$C \leftarrow c$
EI		1	1	1	1	1	1	1	1	$IME \leftarrow 1$
		1	0	1	1	0	0	1	0	
DI		1	1	1	1	1	1	1	0	$IME \leftarrow 0$
		1	0	1	1	0	0	1	0	
IDLE		1	1	1	1	1	1	1	1	$PCON.2 \leftarrow 1$
		1	0	1	0	0	0	1	1	
STOP		1	1	1	1	1	1	1	1	$PCON.3 \leftarrow 1$
		1	0	1	1	0	0	1	1	
NOP		1	0	1	0	0	0	0	0	No operation
SMB	n	1	1	0	1	1	1	0	1	$SMB \leftarrow n$ ( $n = 0, 1, 15$ )
		0	1	0	0	d3	d2	d1	d0	
SRB	n	1	1	0	1	1	1	0	1	$SRB \leftarrow n$ ( $n = 0, 1, 2, 3$ )
		0	1	0	1	0	0	d1	d0	
REF	memc	t7	t6	t5	t4	t3	t2	t1	t0	$PC11-0 = memc7-4, memc3-0 < 1$
VENTn	EMB (0,1) ERB (0,1) ADR	E	E	0	0	a11	a10	a9	a8	ROM (2 x n) 7-6 $\leftarrow$ EMB, ERB ROM (2 x n) 5-4 $\leftarrow$ 0 ROM (2 x n) 3-0 $\leftarrow$ PC11-8 ROM (2 x n+1) 7-0 $\leftarrow$ PC7-0 ( $n = 0, 1, 2, 3, 4, 5, 6, 7$ )
		M	R							
		B	B							
		a7	a6	a5	a4	a3	a2	a1	a0	

Table 5-16. Program Control Instructions — Binary Code Summary

Name	Operand	Binary Code								Operation Notation
CPSE	R,#im	1	1	0	1	1	0	0	1	Skip if R = im
		d3	d2	d1	d0	0	r2	r1	r0	
	@HL,#im	1	1	0	1	1	1	0	1	Skip if (HL) = im
		0	1	1	1	d3	d2	d1	d0	
	A,R	1	1	0	1	1	1	0	1	Skip if A = R
		0	1	1	0	1	r2	r1	r0	
	A,@HL	0	0	1	1	1	0	0	0	Skip if A = (HL)
EA,@HL	1	1	0	1	1	1	0	0	Skip if A = (HL), E = (HL+1)	
	0	0	0	0	1	0	0	1		
EA,RR	1	1	0	1	1	1	0	0	Skip if EA = RR	
	1	1	1	0	1	r2	r1	0		
JP	ADR12	1	1	0	1	1	0	1	1	PC11-0 ← ADR12
		0	0	0	0	a11	a10	a9	a8	
		a7	a6	a5	a4	a3	a2	a1	a0	
JPS	ADR12	1	0	0	1	a11	a10	a9	a8	PC11-0 ← ADR12
		a7	a6	a5	a4	a3	a2	a1	a0	
JR	#im *	www.DataSheet4U.com								PC11-0 ← ADR (PC-15 to PC+16)
	@WX	1	1	0	1	1	1	0	1	PC11-0 ← PC11-8 + (WX)
		0	1	1	0	0	1	0	0	
	@EA	1	1	0	1	1	1	0	1	PC11-0 ← PC11-8 + (EA)
0		1	1	0	0	0	0	0		
CALL	ADR12	1	1	0	1	1	0	1	1	[(SP-1) (SP-2)] ← EMB, ERB [(SP-3) (SP-4)] ← PC7-0
		0	1	0	0	a11	a10	a9	a8	[(SP-5) (SP-6)] ← PC11-8 SP ← SP - 6
		a7	a6	a5	a4	a3	a2	a1	a0	PC11-0 ← ADR12
CALLS	ADR11	1	1	1	0	1	a10	a9	a8	[(SP-1) (SP-2)] ← EMB, ERB [(SP-3) (SP-4)] ← PC7-0 [(SP-5) (SP-6)] ← PC11-8
		a7	a6	a5	a4	a3	a2	a1	a0	SP ← SP - 6 PC11 ← 0 PC10-0 ← ADR11

* JR #im	First Byte							Condition		
	0	0	0	1	a3	a2	a1	a0	PC ← PC+2 to PC+16	
	0	0	0	0	a3	a2	a1	a0	PC ← PC-1 to PC-15	

Table 5-16. Program Control Instructions — Binary Code Summary (Continued)

Name	Operand	Binary Code								Operation Notation
RET	—	1	1	0	0	0	1	0	1	PC11–8 ← (SP + 1) (SP) PC7–0 ← (SP + 2) (SP + 3) EMB,ERB ← (SP + 5) (SP + 4) SP ← SP + 6
IRET	—	1	1	0	1	0	1	0	1	PC11–8 ← (SP + 1) (SP) PC7–0 ← (SP + 2) (SP + 3) PSW ← (SP + 4) (SP + 5) SP ← SP + 6
SRET	—	1	1	1	0	0	1	0	1	PC11–8 ← (SP + 1) (SP) PC7–0 ← (SP + 3) (SP + 2) EMB,ERB ← (SP + 5) (SP + 4) SP ← SP + 6, then skip

Table 5-17. Data Transfer Instructions — Binary Code Summary

Name	Operand	Binary Code								Operation Notation
XCH	A,DA	0	1	1	1	1	0	0	1	A ↔ DA
		a7	a6	a5	a4	a3	a2	a1	a0	
	A,Ra	0	1	1	0	1	r2	r1	r0	A ↔ Ra
	A,@RRa	0	1	1	1	1	i2	i1	i0	A ↔ (RRa)
	EA,DA	1	1	0	0	1	1	1	1	A ↔ DA, E ↔ DA + 1
		a7	a6	a5	a4	a3	a2	a1	a0	
	EA,RRb	1	1	0	1	1	1	0	0	EA ↔ RRb
		1	1	1	0	0	r2	r1	0	
EA,@HL	1	1	0	1	1	1	0	0	A ↔ (HL), E ↔ (HL + 1)	
	0	0	0	0	0	0	0	1		
XCHI	A,@HL	0	1	1	1	1	0	1	0	A ↔ (HL), then L ← L+1; skip if L = 0H
XCHD	A,@HL	0	1	1	1	1	0	1	1	A ↔ (HL), then L ← L-1; skip if L = 0FH
LD	A,#im	1	0	1	1	d3	d2	d1	d0	A ← im
	A,@RRa	1	0	0	0	1	i2	i1	i0	A ← (RRa)
	A,DA	1	0	0	0	1	1	0	0	A ← DA
		a7	a6	a5	a4	a3	a2	a1	a0	
	A,Ra	1	1	0	1	1	1	0	1	A ← Ra
		0	0	0	0	1	r2	r1	r0	

Table 5-17. Data Transfer Instructions — Binary Code Summary (Continued)

Name	Operand	Binary Code								Operation Notation
LD	Ra,#im	1	1	0	1	1	0	0	1	Ra ← im
		d3	d2	d1	d0	1	r2	r1	r0	
	RR,#imm	1	0	0	0	0	r2	r1	1	RR ← imm
		d7	d6	d5	d4	d3	d2	d1	d0	
	DA,A	1	0	0	0	1	0	0	1	DA ← A
		a7	a6	a5	a4	a3	a2	a1	a0	
	Ra,A	1	1	0	1	1	1	0	1	Ra ← A
		0	0	0	0	0	r2	r1	r0	
	EA,@HL	1	1	0	1	1	1	0	0	A ← (HL), E ← (HL + 1)
		0	0	0	0	1	0	0	0	
	EA,DA	1	1	0	0	1	1	1	0	A ← DA, E ← DA + 1
		a7	a6	a5	a4	a3	a2	a1	a0	
	EA,RRb	1	1	0	1	1	1	0	0	EA ← RRb
		1	1	1	1	1	r2	r1	0	
	@HL,A	1	1	0	0	0	1	0	0	(HL) ← A
	DA,EA	1	1	0	0	1	1	0	1	DA ← A, DA + 1 ← E
a7		a6	a5	a4	a3	a2	a1	a0		
RRb,EA	1	1	0	1	1	1	0	0	RRb ← EA	
	1	1	1	1	0	r2	r1	0		
@HL,EA	1	1	0	1	1	1	0	0	(HL) ← A, (HL + 1) ← E	
	0	0	0	0	0	0	0	0		
LDI	A,@HL	1	0	0	0	1	0	1	0	A ← (HL), then L ← L+1; skip if L = 0H
LDD	A,@HL	1	0	0	0	1	0	1	1	A ← (HL), then L ← L-1; skip if L = 0FH
LDC	EA,@WX	1	1	0	0	1	1	0	0	EA ← [PC11-8 + (WX)]
	EA,@EA	1	1	0	0	1	0	0	0	EA ← [PC11-8 + (EA)]
RRC	A	1	0	0	0	1	0	0	0	C ← A.0, A3 ← C A.n-1 ← A.n (n = 1, 2, 3)
PUSH	RR	0	0	1	0	1	r2	r1	1	((SP-1)) ((SP-2)) ← (RR), (SP) ← (SP)-2
	SB	1	1	0	1	1	1	0	1	((SP-1)) ← (SMB), ((SP-2)) ← (SRB), (SP) ← (SP)-2
		0	1	1	0	0	1	1	1	



Table 5-17. Data Transfer Instructions — Binary Code Summary (Concluded)

Name	Operand	Binary Code								Operation Notation
POP	RR	0	0	1	0	1	r2	r1	0	$RR_L \leftarrow (SP), RR_H \leftarrow (SP + 1)$ $SP \leftarrow SP + 2$
	SB	1	1	0	1	1	1	0	1	$(SRB) \leftarrow (SP), SMB \leftarrow (SP + 1),$ $SP \leftarrow SP + 2$
		0	1	1	0	0	1	1	0	

Table 5-18. Logic Instructions — Binary Code Summary

Name	Operand	Binary Code								Operation Notation
AND	A,#im	1	1	0	1	1	1	0	1	$A \leftarrow A \text{ AND } im$
		0	0	0	1	d3	d2	d1	d0	
	A,@HL	0	0	1	1	1	0	0	1	$A \leftarrow A \text{ AND } (HL)$
	EA,RR	1	1	0	1	1	1	0	0	$EA \leftarrow EA \text{ AND } RR$
		0	0	0	1	1	r2	r1	0	
	RRb,EA	1	1	0	1	1	1	0	0	$RRb \leftarrow RRb \text{ AND } EA$
0		0	0	1	0	r2	r1	0		
OR	A, #im	1	1	0	1	1	1	0	1	$A \leftarrow A \text{ OR } im$
		0	0	1	0	d3	d2	d1	d0	
	A, @HL	0	0	1	1	1	0	1	0	$A \leftarrow A \text{ OR } (HL)$
	EA,RR	1	1	0	1	1	1	0	0	$EA \leftarrow EA \text{ OR } RR$
		0	0	1	0	1	r2	r1	0	
	RRb,EA	1	1	0	1	1	1	0	0	$RRb \leftarrow RRb \text{ OR } EA$
0		0	1	0	0	r2	r1	0		
XOR	A,#im	1	1	0	1	1	1	0	1	$A \leftarrow A \text{ XOR } im$
		0	0	1	1	d3	d2	d1	d0	
	A,@HL	0	0	1	1	1	0	1	1	$A \leftarrow A \text{ XOR } (HL)$
	EA,RR	1	1	0	1	1	1	0	0	$EA \leftarrow EA \text{ XOR } (RR)$
		0	0	1	1	0	r2	r1	0	
	RRb,EA	1	1	0	1	1	1	0	0	$RRb \leftarrow RRb \text{ XOR } EA$
0		0	1	1	0	r2	r1	0		
COM	A	1	1	0	1	1	1	0	1	$A \leftarrow A$
		0	0	1	1	1	1	1	1	

Table 5-19. Arithmetic Instructions — Binary Code Summary

Name	Operand	Binary Code								Operation Notation
ADC	A,@HL	0	0	1	1	1	1	1	0	$C, A \leftarrow A + (HL) + C$
	EA,RR	1	1	0	1	1	1	0	0	$C, EA \leftarrow EA + RR + C$
		1	0	1	0	1	r2	r1	0	
	RRb,EA	1	1	0	1	1	1	0	0	$C, RRb \leftarrow RRb + EA + C$
		1	0	1	0	0	r2	r1	0	
ADS	A,#im	1	0	1	0	d3	d2	d1	d0	$A \leftarrow A + im$ ; skip on carry
	EA,#imm	1	1	0	0	1	0	0	1	$EA \leftarrow EA + imm$ ; skip on carry
		d7	d6	d5	d4	d3	d2	d1	d0	
	A,@HL	0	0	1	1	1	1	1	1	$A \leftarrow A + (HL)$ ; skip on carry
	EA,RR	1	1	0	1	1	1	0	0	$EA \leftarrow EA + RR$ ; skip on carry
		1	0	0	1	1	r2	r1	0	
	RRb,EA	1	1	0	1	1	1	0	0	$RRb \leftarrow RRb + EA$ ; skip on carry
1		0	0	1	0	r2	r1	0		
SBC	A,@HL	0	0	1	1	1	1	0	0	$C, A \leftarrow A - (HL) - C$
	EA,RR	1	1	0	1	1	1	0	0	$C, EA \leftarrow EA - RR - C$
		1	1	0	0	1	r2	r1	0	
	RRb,EA	1	1	0	1	1	1	0	0	$C, RRb \leftarrow RRb - EA - C$
		1	1	0	0	0	r2	r1	0	
SBS	A,@HL	0	0	1	1	1	1	0	1	$A \leftarrow A - (HL)$ ; skip on borrow
	EA,RR	1	1	0	1	1	1	0	0	$EA \leftarrow EA - RR$ ; skip on borrow
		1	0	1	1	1	r2	r1	0	
	RRb,EA	1	1	0	1	1	1	0	0	$RRb \leftarrow RRb - EA$ ; skip on borrow
		1	0	1	1	0	r2	r1	0	
DECS	R	0	1	0	0	1	r2	r1	r0	$R \leftarrow R - 1$ ; skip on borrow
	RR	1	1	0	1	1	1	0	0	$RR \leftarrow RR - 1$ ; skip on borrow
		1	1	0	1	1	r2	r1	0	
INCS	R	0	1	0	1	1	r2	r1	r0	$R \leftarrow R + 1$ ; skip on carry
	DA	1	1	0	0	1	0	1	0	$DA \leftarrow DA + 1$ ; skip on carry
		a7	a6	a5	a4	a3	a2	a1	a0	
	@HL	1	1	0	1	1	1	0	1	$(HL) \leftarrow (HL) + 1$ ; skip on carry
		0	1	1	0	0	0	1	0	
RRb	1	0	0	0	0	r2	r1	0	$RRb \leftarrow RRb + 1$ ; skip on carry	

Table 5-20. Bit Manipulation Instructions — Binary Code Summary

Name	Operand	Binary Code								Operation Notation
BTST	C	1	1	0	1	0	1	1	1	Skip if C = 1
	DA.b	1	1	b1	b0	0	0	1	1	Skip if DA.b = 1
		a7	a6	a5	a4	a3	a2	a1	a0	
	mema.b *	1	1	1	1	1	0	0	1	Skip if mema.b = 1
	memb.@L	1	1	1	1	1	0	0	1	Skip if [memb.7-2 + L.3-2]. [L.1-0] = 1
0		1	0	0	a5	a4	a3	a2		
@H+DA.b	1	1	1	1	1	0	0	1	Skip if [H + DA.3-0].b = 1	
	0	0	b1	b0	a3	a2	a1	a0		
BTSF	DA.b	1	1	b1	b0	0	0	1	0	Skip if DA.b = 0
		a7	a6	a5	a4	a3	a2	a1	a0	
	mema.b *	1	1	1	1	1	0	0	0	Skip if mema.b = 0
	memb.@L	1	1	1	1	1	0	0	0	Skip if [memb.7-2 + L.3-2]. [L.1-0] = 0
		0	1	0	0	a5	a4	a3	a2	
@H DA.b	1	1	1	1	1	0	0	0	Skip if [H + DA.3-0].b = 0	
	0	0	b1	b0	a3	a2	a1	a0		
BTSTZ	mema.b *	1	1	1	1	1	1	0	1	Skip if mema.b = 1 and clear
	memb.@L	1	1	1	1	1	1	0	1	Skip if [memb.7-2 + L.3-2]. [L.1-0] = 1 and clear
		0	1	0	0	a5	a4	a3	a2	
	@H+DA.b	1	1	1	1	1	1	0	1	Skip if [H + DA.3-0].b = 1 and clear
		0	0	b1	b0	a3	a2	a1	a0	
BITS	DA.b	1	1	b1	b0	0	0	0	1	DA.b ← 1
		a7	a6	a5	a4	a3	a2	a1	a0	
	mema.b *	1	1	1	1	1	1	1	1	mema.b ← 1
	memb.@L	1	1	1	1	1	1	1	1	[memb.7-2 + L.3-2].b [L.1-0] ← 1
		0	1	0	0	a5	a4	a3	a2	
@H+DA.b	1	1	1	1	1	1	1	1	[H + DA.3-0].b ← 1	
	0	0	b1	b0	a3	a2	a1	a0		

Table 5-20. Bit Manipulation Instructions — Binary Code Summary (Continued)

Name	Operand	Binary Code								Operation Notation	
BITR	DA.b	1	1	b1	b0	0	0	0	0	DA.b ← 0	
		a7	a6	a5	a4	a3	a2	a1	a0		
	mema.b *	1	1	1	1	1	1	1	0	mema.b ← 0	
	memb.@L		1	1	1	1	1	1	1	0	[memb.7–2 + L3–2].[L.1–0] ← 0
			0	1	0	0	a5	a4	a3	a2	
@H+DA.b		1	1	1	1	1	1	1	0	[H + DA.3–0].b ← 0	
		0	0	b1	b0	a3	a2	a1	a0		
BAND	C,mema.b *	1	1	1	1	0	1	0	1	C ← C AND mema.b	
	C,memb.@L		1	1	1	1	0	1	0	1	C ← C AND [memb.7–2 + L.3–2]. [L.1–0]
			0	1	0	0	a5	a4	a3	a2	
	C,@H+DA.b		1	1	1	1	0	1	0	1	C ← C AND [H + DA.3–0].b
			0	0	b1	b0	a3	a2	a1	a0	
BOR	C,mema.b *	1	1	1	1	0	1	1	0	C ← C OR mema.b	
	C,memb.@L		1	1	1	1	0	1	1	0	C ← C OR [memb.7–2 + L.3–2]. [L.1–0]
			0	1	0	0	a5	a4	a3	a2	
	C,@H+DA.b		1	1	1	1	0	1	1	0	C ← C OR [H + DA.3–0].b
			0	0	b1	b0	a3	a2	a1	a0	
BXOR	C,mema.b *	1	1	1	1	0	1	1	1	C ← C XOR mema.b	
	C,memb.@L		1	1	1	1	0	1	1	1	C ← C XOR [memb.7–2 + L.3–2]. [L.1–0]
			0	1	0	0	a5	a4	a3	a2	
	C,@H+DA.b		1	1	1	1	0	1	1	1	C ← C XOR [H + DA.3–0].b
			0	0	b1	b0	a3	a2	a1	a0	

* mema.b	Second Byte								Bit Addresses	
	1	0	b1	b0	a3	a2	a1	a0	FB0H–FBFH	
1	1	b1	b0	a3	a2	a1	a0	FF1H–FF9H		

Table 5-20. Bit Manipulation Instructions — Binary Code Summary (Concluded)

Name	Operand	Binary Code								Operation Notation
LDB	mema.b,C *	1	1	1	1	1	1	0	0	mema.b ← C
	memb.@L,C	1	1	1	1	1	1	0	0	memb.7-2 + [L.3-2]. [L.1-0] ← C
		0	1	0	0	a5	a4	a3	a2	
	@H+DA.b,C	1	1	1	1	1	1	0	0	H + [DA.3-0].b ← (C)
		0	b2	b1	b0	a3	a2	a1	a0	
	C,mema.b *	1	1	1	1	0	1	0	0	C ← mema.b
	C,memb.@L	1	1	1	1	0	1	0	0	C ← memb.7-2 + [L.3-2] . [L.1-0]
		0	1	0	0	a5	a4	a3	a2	
	C,@H+DA.b	1	1	1	1	0	1	0	0	C ← [H + DA.3-0].b
		0	b2	b1	b0	a3	a2	a1	a0	

* mema.b	Second Byte								Bit Addresses
	1	0	b1	b0	a3	a2	a1	a0	FB0H-FBFH
1	1	b1	b0	a3	a2	a1	a0	FF0H-FFFH	

## INSTRUCTION DESCRIPTIONS

This Chapter contains detailed information and programming examples for each instruction of the SAM47 instruction set. Information is arranged in a consistent format to improve readability and for use as a quick-reference resource for application programmers.

If you are reading this user's manual for the first time, please just scan this very detailed information briefly in order to acquaint yourself with the basic features of the instruction set. The information elements of the instruction description format are as follows:

- Instruction name (mnemonic)
- Full instruction name
- Source/destination format of the instruction operand
- Operation overview (from the "High-Level Summary" table)
- Textual description of the instruction's effect
- Binary code overview (from the "Binary Code Summary" table)
- Programming example(s) to show how the instruction is used

www.DataSheet4U.com

## ADC — Add With Carry

ADC dst,src

Operation:	Operand	Operation Summary	Bytes	Cycles
	A,@HL	Add indirect data memory to A with carry	1	1
	EA,RR	Add register pair (RR) to EA with carry	2	2
	RRb,EA	Add EA to register pair (RRb) with carry	2	2

**Description:** The source operand, along with the setting of the carry flag, is added to the destination operand and the sum is stored in the destination. The contents of the source are unaffected. If there is an overflow from the most significant bit of the result, the carry flag is set; otherwise, the carry flag is cleared.

If 'ADC A,@HL' is followed by an 'ADS A,#im' instruction in a program, ADC skips the ADS instruction if an overflow occurs. If there is no overflow, the ADS instruction is executed normally. (This condition is valid only for 'ADC A,@HL' instructions. If an overflow occurs following an 'ADS A,#im' instruction, the next instruction will not be skipped.)

Operand	Binary Code								Operation Notation
A,@HL	0	0	1	1	1	1	1	0	C, A ← A + (HL) + C
EA,RR	1	1	0	1	1	0	0	0	C, EA ← EA + RR + C
	1	0	1	0	1	r2	r1	0	
RRb,EA	1	1	0	1	1	1	0	0	C, RRb ← RRb + EA + C
	1	0	1	0	0	r2	r1	0	

**Examples:** 1. The extended accumulator contains the value 0C3H, register pair HL the value 0AAH, and the carry flag is set to "1":

```
SCF          ; C ← "1"
ADC    EA,HL  ; EA ← 0C3H + 0AAH + 1H = 6EH, C ← "1"
JPS    XXX    ; Jump to XXX; no skip after ADC
```

2. If the extended accumulator contains the value 0C3H, register pair HL the value 0AAH, and the carry flag is cleared to "0":

```
RCF          ; C ← "0"
ADC    EA,HL  ; EA ← 0C3H + 0AAH + 0H = 6EH, C ← "1"
JPS    XXX    ; Jump to XXX; no skip after ADC
```

## ADC — Add With Carry

**ADC** (Continued)

**Examples:** 3. If ADC A,@HL is followed by an ADS A,#im, the ADC skips on carry to the instruction immediately after the ADS. An ADS instruction immediately after the ADC does not skip even if an overflow occurs. This function is useful for decimal adjustment operations.

a. 8 + 9 decimal addition (the contents of the address specified by the HL register is 9H):

```
RCF                ; C ← "0"
LD      A,#8H      ; A ← 8H
ADS     A,#6H      ; A ← 8H + 6H = 0EH
ADC     A,@HL      ; A ← 7H, C ← "1"
ADS     A,#0AH     ; Skip this instruction because C = "1" after ADC result
JPS     XXX
```

b. 3 + 4 decimal addition (the contents of the address specified by the HL register is 4H):

```
RCF                ; C ← "0"
LD      A,#3H      ; A ← 3H
ADS     A,#6H      ; A ← 3H + 6H = 9H
ADC     A,@HL      ; A ← 9H + 4H + C(0) = 0DH
ADS     A,#0AH     ; No skip. A ← 0DH + 0AH = 7H
                ; (The skip function for 'ADS A,#im' is inhibited after an
                ; 'ADC A,@HL' instruction even if an overflow occurs.)
JPS     XXX
```



## ADS — Add And Skip On Overflow

ADS            dst,src

Operation:	Operand	Operation Summary	Bytes	Cycles
	A, #im	Add 4-bit immediate data to A and skip on overflow	1	1 + S
	EA, #imm	Add 8-bit immediate data to EA and skip on overflow	2	2 + S
	A, @HL	Add indirect data memory to A and skip on overflow	1	1 + S
	EA, RR	Add register pair (RR) contents to EA and skip on overflow	2	2 + S
	RRb, EA	Add EA to register pair (RRb) and skip on overflow	2	2 + S

**Description:** The source operand is added to the destination operand and the sum is stored in the destination. The contents of the source are unaffected. If there is an overflow from the most significant bit of the result, the skip signal is generated and a skip is executed, but the carry flag value is unaffected.

If 'ADS A, #im' follows an 'ADC A, @HL' instruction in a program, ADC skips the ADS instruction if an overflow occurs. If there is no overflow, the ADS instruction is executed normally. This skip condition is valid only for 'ADC A, @HL' instructions, however. If an overflow occurs following an ADS instruction, the next instruction is not skipped.

Operand	Binary Code								Operation Notation
A, #im	1	0	1	0	d3	d2	d1	d0	$A \leftarrow A + im$ ; skip on overflow
EA, #imm	1	1	0	0	1	0	0	1	$EA \leftarrow EA + imm$ ; skip on overflow
	d7	d6	d5	d4	d3	d2	d1	d0	
A, @HL	0	0	1	1	1	1	1	1	$A \leftarrow A + (HL)$ ; skip on overflow
EA, RR	1	1	0	1	1	1	0	0	$EA \leftarrow EA + RR$ ; skip on overflow
	1	0	0	1	1	r2	r1	0	
RRb, EA	1	1	0	1	1	1	0	0	$RRb \leftarrow RRb + EA$ ; skip on overflow
	1	0	0	1	0	r2	r1	0	

**Examples:** 1. The extended accumulator contains the value 0C3H, register pair HL the value 0AAH, and the carry flag = "0":

```

ADS    EA,HL           ; EA ← 0C3H + 0AAH = 6DH, C ← "0"
                          ; ADS skips on overflow, but carry flag value is not affected.
JPS    XXX             ; This instruction is skipped since ADS had an overflow.
JPS    YYY             ; Jump to YYY.

```

## ADS — Add And Skip On Overflow

**ADS** (Continued)

**Examples:** 2. If the extended accumulator contains the value 0C3H, register pair HL the value 12H, and the carry flag = "0":

```
ADS    EA,HL           ; EA ← 0C3H + 12H = 0D5H, C ← "0"
JPS    XXX             ; Jump to XXX; no skip after ADS.
```

3. If 'ADC A,@HL' is followed by an 'ADS A,#im', the ADC skips on overflow to the instruction immediately after the ADS. An 'ADS A,#im' instruction immediately after the 'ADC A,@HL' does not skip even if overflow occurs. This function is useful for decimal adjustment operations.

a. 8 + 9 decimal addition (the contents of the address specified by the HL register is 9H):

```
RCF                    ; C ← "0"
LD    A,#8H           ; A ← 8H
ADS   A,#6H           ; A ← 8H + 6H = 0EH
ADC   A,@HL           ; A ← 7H, C ← "1"
ADS   A,#0AH          ; Skip this instruction because C = "1" after ADC result.
JPS   XXX
```

b. 3 + 4 decimal addition (the contents of the address specified by the HL register is 4H):

```
RCF                    ; C ← "0"
LD    A,#3H           ; A ← 3H
ADS   A,#6H           ; A ← 3H + 6H = 9H
ADC   A,@HL           ; A ← 9H + 4H + C(0) = 0DH
ADS   A,#0AH          ; No skip. A ← 0DH + 0AH = 7H
                        ; (The skip function for 'ADS A,#im' is inhibited after an
                        ; 'ADC A,@HL' instruction even if an overflow occurs.)
JPS   XXX
```

## AND — Logical And

AND dst,src

Operation:	Operand	Operation Summary	Bytes	Cycles
	A,#im	Logical-AND A immediate data to A	2	2
	A,@HL	Logical-AND A indirect data memory to A	1	1
	EA,RR	Logical-AND register pair (RR) to EA	2	2
	RRb,EA	Logical-AND EA to register pair (RRb)	2	2

**Description:** The source operand is logically ANDed with the destination operand. The result is stored in the destination. The logical AND operation results in a "1" bit being stored whenever the corresponding bits in the two operands are both "1"; otherwise a "0" bit is stored. The contents of the source are unaffected.

Operand	Binary Code								Operation Notation
A,#im	1	1	0	1	1	1	0	1	A ← A AND im
	0	0	0	1	d3	d2	d1	d0	
A,@HL	0	0	1	1	1	0	0	1	A ← A AND (HL)
EA,RR	1	1	0	1	1	1	0	0	EA ← EA AND RR
	0	0	0	1	1	r2	r1	0	
RRb,EA	1	1	0	1	1	1	0	0	RRb ← RRb AND EA
	0	0	0	1	0	r2	r1	0	

**Example:** If the extended accumulator contains the value 0C3H (11000011B) and register pair HL the value 55H (01010101B), the instruction

```
AND EA,HL
```

leaves the value 41H (01000001B) in the extended accumulator EA .

## BAND — Bit Logical And

**BAND** C,src.b

Operation:	Operand	Operation Summary	Bytes	Cycles
	C,mema.b	Logical-AND carry flag with memory bit	2	2
	C,memb.@L		2	2
	C,@H+DA.b		2	2

**Description:** The specified bit of the source is logically ANDed with the carry flag bit value. If the Boolean value of the source bit is a logic zero, the carry flag is cleared to "0"; otherwise, the current carry flag setting is left unaltered. The bit value of the source operand is not affected.

Operand	Binary Code								Operation Notation
C,mema.b *	1	1	1	1	0	1	0	1	C ← C AND mema.b
C,memb.@L	1	1	1	1	0	1	0	1	C ← C AND [memb.7–2 + L.3–2]. [L.1–0]
C,@H+DA.b	1	1	1	1	0	1	0	1	C ← C AND [H + DA.3–0].b
	0	0	b1	b0	a3	a2	a1	a0	

	Second Byte								Bit Addresses
* mema.b	1	0	b1	b0	a3	a2	a1	a0	FB0H–FBFH
	1	1	b1	b0	a3	a2	a1	a0	FF0H–FFFH

**Examples:** 1. The following instructions set the carry flag if P1.0 (port 1.0) is equal to "1" (and assuming the carry flag is already set to "1"):

```
SMB    15                ; C ← "1"
BAND   C,P1.0           ; If P1.0 = "1", C ← "1"
                          ; If P1.0 = "0", C ← "0"
```

2. Assume the P1 address is FF1H and the value for register L is 9H (1001B). The address (memb.7–2) is 111100B; (L.3–2) is 10B. The resulting address is 11110010B or FF2H, specifying P2. The bit value for the BAND instruction, (L.1–0) is 01B which specifies bit 1. Therefore, P1.@L = P2.1:

```
LD     L,#9H
BAND   C,P1.@L          ; P1.@L is specified as P2.1
                          ; C AND P2.1
```

## BAND — Bit Logical And

**BAND** (Continued)

**Examples:** 3. Register H contains the value 2H and FLAG = 20H.3. The address of H is 0010B and FLAG (3–0) is 0000B. The resulting address is 00100000B or 20H. The bit value for the BAND instruction is 3. Therefore, @H+FLAG = 20H.3:

```
FLAG    EQU 20H.3
LD      H,#2H
BAND    C,@H+FLAG    ; C AND FLAG (20H.3)
```

www.DataSheet4U.com

## BITR — Bit Reset

BITR            dst.b

Operation:	Operand	Operation Summary	Bytes	Cycles
	DA.b	Clear specified memory bit to logic zero	2	2
	mema.b		2	2
	memb.@L		2	2
	@H+DA.b		2	2

**Description:** A BITR instruction clears to logic zero (resets) the specified bit within the destination operand. No other bits in the destination are affected.

Operand	Binary Code								Operation Notation
DA.b	1	1	b1	b0	0	0	0	0	DA.b ← 0
	a7	a6	a5	a4	a3	a2	a1	a0	
mema.b *	1	1	1	1	1	1	1	0	mema.b ← 0
memb.@L	1	1	1	1	1	1	1	0	[memb.7–2 + L3–2].[L.1–0] ← 0
	0	1	0	0	a5	a4	a3	a2	
@H+DA.b	1	1	1	1	1	1	1	0	[H + DA.3–0].b ← 0
	0	0	b1	b0	a3	a2	a1	a0	

	Second Byte								Bit Addresses
* mema.b	1	0	b1	b0	a3	a2	a1	a0	FB0H–FBFH
	1	1	b1	b0	a3	a2	a1	a0	FF0H–FFFH

### Examples:

1. Bit location 30H.2 in the RAM has a current value of logic one. The following instruction clears the third bit in RAM location 30H (bit 2) to logic zero:

```
BITR 30H.2 ; 30H.2 ← "0"
```

2. You can use BITR in the same way to manipulate a port address bit:

```
BITR P2.0 ; P2.0 ← "0"
```

## BITR — Bit Reset

**BITR** (Continued)

**Examples:** 3. Assuming that P2.2, P2.3, and P3.0–P3.3 are cleared to "0":

```

BP2    LD    L,#0AH
        BITR  P1.@L    ; First, P1.@0AH = P2.2
                                ; (1111100B) + 10B.10B = 0F2H.2
        INCS  L
        JR    BP2

```

4. If bank 0, location 0A0H.0 is cleared (and regardless of whether the EMB value is logic zero), BITR has the following effect:

```

FLAG    EQU    0A0H.0
        •
        •
        •
        BITR  EMB
        •
        •
        •
        LD    H,#0AH
        BITR  @H+FLAG ; Bank 0 (AH + 0H).0 = 0A0H.0 ← "0"

```

**NOTE:** Since the BITR instruction is used for output functions, the pin names used in the examples above may change for different devices in the SAM47 product family.

# BITS — Bit Set

**BITS** dst.b

Operation:	Operand	Operation Summary	Bytes	Cycles
	DA.b	Set specified memory bit	2	2
	mema.b		2	2
	memb.@L		2	2
	@H+DA.b		2	2

**Description:** This instruction sets the specified bit within the destination without affecting any other bits in the destination. BITS can manipulate any bit that is addressable using direct or indirect addressing modes.

Operand	Binary Code								Operation Notation
DA.b	1	1	b1	b0	0	0	0	1	DA.b ← 1
	a7	a6	a5	a4	a3	a2	a1	a0	
mema.b *	1	1	1	1	1	1	1	1	mema.b ← 1
memb.@L	1	1	1	1	1	1	1	1	[memb.7-2 + L.3-2].b [L.1-0] ← 1
	0	1	0	0	a5	a4	a3	a2	
@H+DA.b	1	1	1	1	1	1	1	1	[H + DA.3-0].b ← 1
	0	0	b1	b0	a3	a2	a1	a0	

* mema.b	Second Byte								Bit Addresses
	1	0	b1	b0	a3	a2	a1	a0	FB0H-FBFH
1	1	b1	b0	a3	a2	a1	a0	FF0H-FFFH	

**Examples:** 1. Assuming that bit location 30H.2 in the RAM has a current value of "0", the following instruction sets the second bit of location 30H to "1".

```
BITS    30H.2                ; 30H.2 ← "1"
```

2. You can use BITS in the same way to manipulate a port address bit:

```
BITS    P2.0d                ; P2.0 ← "1"
```



## BITS — Bit Set

**BITS** (Continued)

**Examples:** 3. Given that P2.2, P2.3, and P3.0–P3.3 are set to "1":

```

BP2    LD    L,#0AH
        BITS  P1.@L    ; First, P1.@0AH = P2.2
                                ; (1111100B) + 10B.10B = 0F2H.2
        INCS  L
        JR    BP2
  
```

4. If bank 0, location 0A0H.0, is set to "1" and the EMB = "0", BITS has the following effect:

```

FLAG   EQU   0A0H.0
        •
        •
        •
        BITR  EMB
        •
        •
        LD    H,#0AH
        BITS  @H+FLAG ; Bank 0 (AH + 0H).0 = 0A0H.0 ← "1"
  
```

**NOTE:** Since the BITS instruction is used for output functions, pin names used in the examples above may change for different devices in the SAM47 product family.

# BOR — Bit Logical OR

**BOR** C,src.b

Operation:	Operand	Operation Summary	Bytes	Cycles
	C,mema.b	Logical-OR carry with specified memory bit	2	2
	C,memb.@L		2	2
	C,@H+DA.b		2	2

**Description:** The specified bit of the source is logically ORed with the carry flag bit value. The value of the source is unaffected.

Operand	Binary Code								Operation Notation
C,mema.b *	1	1	1	1	0	1	1	0	C ← C OR mema.b
C,memb.@L	1	1	1	1	0	1	1	0	C ← C OR [memb.7–2 + L.3–2]. [L.1–0]
	0	1	0	0	a5	a4	a3	a2	
C,@H+DA.b	1	1	1	1	0	1	1	0	C ← C OR [H + DA.3–0].b
	0	0	b1	b0	a3	a2	a1	a0	

	Second Byte								Bit Addresses
* mema.b	1	0	b1	b0	a3	a2	a1	a0	FB0H–FBFH
	1	1	b1	b0	a3	a2	a1	a0	FF0H–FFFH

**Examples:** 1. The carry flag is logically ORed with the P1.0 value:

```
RCF          ; C ← "0"
BOR    C,P1.0 ; If P1.0 = "1", then C ← "1"; if P1.0 = "0", then C ← "0"
```

2. The P1 address is FF1H and register L contains the value 9H (1001B). The address (memb.7–2) is 111100B and (L.3–2) = 10B. The resulting address is 11110010B or FF2H, specifying P2. The bit value for the BOR instruction, (L.1–0) is 01B which specifies bit 1. Therefore, P1.@L = P2.1:

```
LD    L,#9H
BOR   C,P1.@L ; P1.@L is specified as P2.1; C OR P2.1
```

## BOR — Bit Logical OR

**BOR** (Continued)

**Examples:** 3. Register H contains the value 2H and FLAG = 20H.3. The address of H is 0010B and FLAG(3–0) is 0000B. The resulting address is 00100000B or 20H. The bit value for the BOR instruction is 3. Therefore, @H+FLAG = 20H.3:

```
FLAG    EQU    20H.3
LD      H,#2H
BOR     C,@H+FLAG    ; C OR FLAG (20H.3)
```

www.DataSheet4U.com

## BTSF — Bit Test and Skip on False

**BTSF** dst.b

Operation:	Operand	Operation Summary	Bytes	Cycles
	DA.b	Test specified memory bit and skip if bit equals "0"	2	2 + S
	mema.b		2	2 + S
	memb.@L		2	2 + S
	@H+DA.b		2	2 + S

**Description:** The specified bit within the destination operand is tested. If it is a "0", the BTSF instruction skips the instruction which immediately follows it; otherwise the instruction following the BTSF is executed. The destination bit value is not affected.

Operand	Binary Code								Operation Notation
DA.b	1	1	b1	b0	0	0	1	0	Skip if DA.b = 0
	a7	a6	a5	a4	a3	a2	a1	a0	
mema.b *	1	1	1	1	1	0	0	0	Skip if mema.b = 0
memb.@L	1	1	1	1	1	0	0	0	Skip if [memb.7-2 + L.3-2]. [L.1-0] = 0
	0	1	0	0	a5	a4	a3	a2	
@H + DA.b	1	1	1	1	1	0	0	0	Skip if [H + DA.3-0].b = 0
	0	0	b1	b0	a3	a2	a1	a0	

		Second Byte							Bit Addresses	
*	mema.b	1	0	b1	b0	a3	a2	a1	a0	FB0H-FBFH
		1	1	b1	b0	a3	a2	a1	a0	FF0H-FFFH

**Examples:**

- If RAM bit location 30H.2 is set to logic zero, the following instruction sequence will cause the program to continue execution from the instruction identified as LABEL2:

```

BTSF    30H.2           ; If 30H.2 = "0", then skip
RET     ; If 30H.2 = "1", return
JP      LABEL2

```

- You can use BTSF in the same way to manipulate a port pin address bit:

```

BTSF    P2.0           ; If P2.0 = "0", then skip
RET     ; If P2.0 = "1", then return
JP      LABEL3

```

## BTSF — Bit Test and Skip on False

**BTSF** (Continued)

**Examples:** 3. P2.2, P2.3 and P3.0–P3.3 are tested:

```

BP2      LD      L,#0AH
          BTSF   P1.@L ; First, P1.@0AH = P2.2
                               ; (1111100B) + 10B.10B = 0F2H.2
          RET
          INCS   L
          JR     BP2
  
```

4. Bank 0, location 0A0H.0, is tested and (regardless of the current EMB value) BTSF has the following effect:

```

FLAG     EQU     0A0H.0
          •
          •
          •
          BITR   EMB
          •
          •
          LD     H,#0AH
          BTSF  @H+FLAG ; If bank 0 (AH + 0H).0 = 0A0H.0 = "0", then skip
          RET
          •
          •
          •
  
```

# BTST — Bit Test and Skip on True

**BTST** dst.b

Operation:	Operand	Operation Summary	Bytes	Cycles
	C	Test carry bit and skip if set (= "1")	1	1 + S
	DA.b	Test specified bit and skip if memory bit is set	2	2 + S
	mema.b		2	2 + S
	memb.@L		2	2 + S
	@H+DA.b		2	2 + S

**Description:** The specified bit within the destination operand is tested. If it is "1", the instruction that immediately follows the BTST instruction is skipped; otherwise the instruction following the BTST instruction is executed. The destination bit value is not affected.

Operand	Binary Code								Operation Notation
C	1	1	0	1	0	1	1	1	Skip if C = 1
DA.b	1	1	b1	b0	0	0	1	1	Skip if DA.b = 1
	a7	a6	a5	a4	a3	a2	a1	a0	
mema.b *	1	1	1	1	1	0	0	1	Skip if mema.b = 1
memb.@L	1	1	1	1	1	0	0	1	Skip if [memb.7–2 + L.3–2]. [L.1–0] = 1
	0	1	0	0	a5	a4	a3	a2	
@H+DA.b	1	1	1	1	1	0	0	1	Skip if [H + DA.3–0].b = 1
	0	0	b1	b0	a3	a2	a1	a0	

	Second Byte								Bit Addresses
* mema.b	1	0	b1	b0	a3	a2	a1	a0	FB0H–FBFH
	1	1	b1	b0	a3	a2	a1	a0	FF0H–FFFH

**Examples:** 1. If RAM bit location 30H.2 is set to logic zero, the following instruction sequence will execute the RET instruction:

```
BTST    30H.2           ; If 30H.2 = "1", then skip
RET                                           ; If 30H.2 = "0", return
JP      LABEL2
```

## BTST — Bit Test and Skip on True

**BTST** (Continued)

**Examples:** 2. You can use BTST in the same way to manipulate a port pin address bit:

```
BTST    P2.0                ; If P2.0 = "1", then skip
RET     ; If P2.0 = "0", then return
JP      LABEL3
```

3. Assume that P2.2, P2.3 and P3.0–P3.3 are cleared to "0":

```
LD      L,#0AH
BP2     BTST P1.@L          ; First, P1.@0AH = P2.2
                          ; (111100B) + 10B.10B = 0F2H.2
RET
INCS   L
JR     BP2
```

4. Bank 0, location 0A0H.0, is tested and (regardless of the current EMB value) BTST has the following effect:

```
FLAG    EQU    0A0H.0
        .
        .
        .
        BITR   EMB
        .
        .
        LD     H,#0AH
        BTST  @H+FLAG ; If bank 0 (AH + 0H).0 = 0A0H.0 = "1", then skip
        RET
        .
        .
        .
```

# BTSTZ — Bit Test and Skip on True; Clear Bit

**BTSTZ** dst.b

Operation:	Operand	Operation Summary	Bytes	Cycles
	mema.b	Test specified bit; skip and clear if memory bit is set	2	2 + S
	memb.@L		2	2 + S
	@H+DA.b		2	2 + S

**Description:** The specified bit within the destination operand is tested. If it is a "1", the instruction immediately following the BTSTZ instruction is skipped; otherwise the instruction following the BTSTZ is executed. The destination bit value is cleared.

Operand	Binary Code								Operation Notation
mema.b *	1	1	1	1	1	1	0	1	Skip if mema.b = 1 and clear
memb.@L	1	1	1	1	1	1	0	1	Skip if [memb.7–2 + L.3–2]. [L.1–0] = 1 and clear
	0	1	0	0	a5	a4	a3	a2	
@H+DA.b	1	1	1	1	1	1	0	1	Skip if [H + DA.3–0].b = 1 and clear
	0	0	b1	b0	a3	a2	a1	a0	

	Second Byte								Bit Addresses
* mema.b	1	0	b1	b0	a3	a2	a1	a0	FB0H–FBFH
	1	1	b1	b0	a3	a2	a1	a0	FF0H–FFFH

**Examples:** 1. Port pin P2.0 is toggled by checking the P2.0 value (level):

```
BTSTZ    P2.0          ; If P2.0 = "1", then P2.0 ← "0" and skip
BITS     P2.0          ; If P2.0 = "0", then P2.0 ← "1"
JP       LABEL3
```

2. Assume that port pins P2.2, P2.3 and P3.0–P3.3 are toggled:

```
BP2      LD      L,#0AH
          BTSTZ   P1.@L ; First, P1.@0AH = P2.2
          ; (111100B) + 10B.10B = 0F2H.2
          RET
          INCS    L
          JR      BP2
```



## BTSTZ — Bit Test and Skip on True; Clear Bit

**BTSTZ** (Continued)

**Examples:** 3. Bank 0, location 0A0H.0, is tested and EMB = "0":

```

FLAG    EQU    0A0H.0
        .
        .
        .
        BITR   EMB
        .
        .
        .
LD      H,#0AH
BTSTZ  @H+FLAG ; If bank 0 (AH + 0H).0 = 0A0H.0 = "1", clear and skip
BITS   @H+FLAG ; If 0A0H.0 = "0", then 0A0H.0 ← "1"

```

www.DataSheet4U.com

# BXOR — Bit Exclusive OR

**BXOR** C,src.b

Operation:	Operand	Operation Summary	Bytes	Cycles
	C,mema.b	Exclusive-OR carry with memory bit	2	2
	C,memb.@L		2	2
	C,@H+DA.b		2	2

**Description:** The specified bit of the source is logically XORed with the carry bit value. The resultant bit is written to the carry flag. The source value is unaffected.

Operand	Binary Code								Operation Notation
C,mema.b *	1	1	1	1	0	1	1	1	C ← C XOR mema.b
C,memb.@L	1	1	1	1	0	1	1	1	C ← C XOR [memb.7–2 + L.3–2]. [L.1–0]
	0	1	0	0	a5	a4	a3	a2	
C,@H+DA.b	1	1	1	1	0	1	1	1	C ← C XOR [H + DA.3–0].b
	0	0	b1	b0	a3	a2	a1	a0	

	Second Byte								Bit Addresses
* mema.b	1	0	b1	b0	a3	a2	a1	a0	FB0H–FBFH
	1	1	b1	b0	a3	a2	a1	a0	FF0H–FFFH

**Examples:** 1. The carry flag is logically XORed with the P1.0 value:

```
RCF                ; C ← "0"
BXOR   C,P1.0      ; If P1.0 = "1", then C ← "1"; if P1.0 = "0", then C ← "0"
```

2. The P1 address is FF1H and register L contains the value 9H (1001B). The address (memb.7–2) is 111100B and (L.3–2) = 10B. The resulting address is 11110010B or FF2H, specifying P2. The bit value for the BXOR instruction, (L.1–0) is 01B which specifies bit 1. Therefore, P1.@L = P2.1:

```
LD      L,#9H
BXOR   C,P1.@L      ; P1.@L is specified as P2.1; C XOR   P2.1
```

## BXOR — Bit Exclusive OR

**BXOR** (Continued)

**Examples:** 3. Register H contains the value 2H and FLAG = 20H.3. The address of H is 0010B and FLAG(3–0) is 0000B. The resulting address is 00100000B or 20H. The bit value for the BOR instruction is 3. Therefore, @H+FLAG = 20H.3:

```
FLAG      EQU  20H.3
LD        H,#2H
BXOR     C,@H+FLAG      ; C XOR FLAG (20H.3)
```

www.DataSheet4U.com

# CALL — Call Procedure

CALL dst

Operation:	Operand	Operation Summary	Bytes	Cycles
	ADR12	Call direct address(12 bits)	3	4

**Description:** CALL calls a subroutine located at the destination address. The instruction adds three to the program counter to generate the return address and then pushes the result onto the stack, decreasing the stack pointer by six. The EMB and ERB are also pushed to the stack. Program execution continues with the instruction at this address. The subroutine may therefore begin anywhere in the full 14-Kbyte program memory address space.

Operand	Binary Code								Operation Notation
ADR12	1	1	0	1	1	0	1	1	[(SP-1) (SP-2)] ← EMB, ERB [(SP-3) (SP-4)] ← PC7-0
	0	1	0	a12	a11	a10	a9	a8	[(SP-5) (SP-6)] ← PC11-8 SP ← SP - 6
	a7	a6	a5	a4	a3	a2	a1	a0	PC11-0 ← ADR12

**Example:** The stack pointer value is 00H and the label 'PLAY' is assigned to program memory location 0E3FH. Executing the instruction

```
CALL PLAY
```

at location 0123H will generate the following values:

```
SP    = 0FAH
0FFH = 0H
0FEH = EMB, ERB
0FDH = 2H
0FCH = 6H
0FBH = 0H
0FAH = 1H
PC    = 0E3FH
```

Data is written to stack locations 0FFH-0FAH as follows:

0FAH	PC11 – PC8			
0FBH	0	0	0	0
0FCH	PC3 – PC0			
0FDH	PC7 – PC4			
0FEH	0	0	EMB	ERB
0FFH	0	0	0	0

## CALLS — Call Procedure (Short)

**CALLS**      dst

Operation:	Operand	Operation Summary	Bytes	Cycles
	ADR11	Call direct address within 2 K (11 bits)	2	3

**Description:** The CALLS instruction unconditionally calls a subroutine located at the indicated address. The instruction increments the PC twice to obtain the address of the following instruction. Then, it pushes the result onto the stack, decreasing the stack pointer six times. The higher bits of the PC, with the exception of the lower 11 bits, are cleared. The subroutine call must therefore be located within the 2-Kbyte block (0000H–07FFH) of program memory.

Operand	Binary Code								Operation Notation
ADR11	1	1	1	0	1	a10	a9	a8	[(SP-1) (SP-2)] ← EMB, ERB [(SP-3) (SP-4)] ← PC7-0 [(SP-5) (SP-6)] ← PC11-8  SP ← SP - 6 PC11 ← 0 PC10-0 ← ADR11
	a7	a6	a5	a4	a3	a2	a1	a0	

**Example:** The stack pointer value is 00H and the label 'PLAY' is assigned to program memory location 0345H. Executing the instruction

```
CALLS    PLAY
```

at location 0123H will generate the following values:

```

SP      = 0FAH
0FFH   = 0H
0FEH   = EMB, ERB
0FDH   = 2H
0FCH   = 5H
0FBH   = 0H
0FAH   = 1H
PC     = 0345H

```

Data is written to stack locations 0FFH–0FAH as follows:

0FAH	PC11 – PC8			
0FBH	0	0	0	0
0FCH	PC3 – PC0			
0FDH	PC7 – PC4			
0FEH	0	0	EMB	ERB
0FFH	0	0	0	0

## CCF — Complement Carry Flag

### CCF

Operation:	Operand	Operation Summary	Bytes	Cycles
	–	Complement carry flag	1	1

**Description:** The carry flag is complemented; if C = "1" it is changed to C = "0" and vice-versa.

Operand	Binary Code								Operation Notation
–	1	1	0	1	0	1	1	0	$C \leftarrow \bar{c}$

**Example:** If the carry flag is logic zero, the instruction

CCF

changes the value to logic one.

www.DataSheet4U.com

## COM — Complement Accumulator

COM      A

Operation:	Operand	Operation Summary	Bytes	Cycles
	A	Complement accumulator (A)	2	2

**Description:** The accumulator value is complemented; if the bit value of A is "1", it is changed to "0" and vice versa.

Operand	Binary Code								Operation Notation
A	1	1	0	1	1	1	0	1	A ← A
	0	0	1	1	1	1	1	1	

**Example:** If the accumulator contains the value 4H (0100B), the instruction

COM A

leaves the value 0BH (1011B) in the accumulator.

www.DataSheet4U.com

## CPSE — Compare and Skip if Equal

CPSE dst,src

Operation:	Operand	Operation Summary	Bytes	Cycles
	R,#im	Compare and skip if register equals #im	2	2 + S
	@HL,#im	Compare and skip if indirect data memory equals #im	2	2 + S
	A,R	Compare and skip if A equals R	2	2 + S
	A,@HL	Compare and skip if A equals indirect data memory	1	1 + S
	EA,@HL	Compare and skip if EA equals indirect data memory	2	2 + S
	EA,RR	Compare and skip if EA equals RR	2	2 + S

**Description:** CPSE compares the source operand (subtracts it from) the destination operand, and skips the next instruction if the values are equal. Neither operand is affected by the comparison.

Operand	Binary Code								Operation Notation
R,#im	1	1	0	1	1	0	0	1	Skip if R = im
	d3	d2	d1	d0	0	r2	r1	r0	
@HL,#im	1	1	0	1	1	1	0	1	Skip if (HL) = im
	0	1	1	1	d3	d2	d1	d0	
A,R	1	1	0	1	1	1	0	1	Skip if A = R
	0	1	1	0	1	r2	r1	r0	
A,@HL	0	0	1	1	1	0	0	0	Skip if A = (HL)
EA,@HL	1	1	0	1	1	1	0	0	Skip if A = (HL), E = (HL+1)
	0	0	0	0	1	0	0	1	
EA,RR	1	1	0	1	1	1	0	0	Skip if EA = RR
	1	1	1	0	1	r2	r1	0	

**Example:** The extended accumulator contains the value 34H and register pair HL contains 56H. The second instruction (RET) in the instruction sequence

```
CPSE EA,HL
RET
```

is not skipped. That is, the subroutine returns since the result of the comparison is 'not equal.'



## DECS — Decrement and Skip on Borrow

DECS      dst

Operation:	Operand	Operation Summary	Bytes	Cycles
	R	Decrement register (R); skip on borrow	1	1 + S
	RR	Decrement register pair (RR); skip on borrow	2	2 + S

**Description:** The destination is decremented by one. An original value of 00H will underflow to 0FFH. If a borrow occurs, a skip is executed. The carry flag value is unaffected.

Operand	Binary Code								Operation Notation
R	0	1	0	0	1	r2	r1	r0	R ← R-1; skip on borrow
RR	1	1	0	1	1	1	0	0	RR ← RR-1; skip on borrow
	1	1	0	1	1	r2	r1	0	

**Examples:** 1. Register pair HL contains the value 7FH (01111111B). The following instruction leaves the value 7EH in register pair HL:

```
DECS    HL
```

2. Register A contains the value 0H. The following instruction sequence leaves the value 0FFH in register A. Since a "borrow" occurs, the 'CALL PLAY1' instruction is skipped and the 'CALL PLAY2' instruction is executed:

```
DECS    A                ; "Borrow" occurs
CALL    PLAY1            ; Skipped
CALL    PLAY2            ; Executed
```

## DI — Disable Interrupts

DI

Operation:	Operand	Operation Summary	Bytes	Cycles
	–	Disable all interrupts	2	2

**Description:** Bit 3 of the interrupt priority register IPR, IME, is cleared to logic zero, disabling all interrupts. Interrupts can still set their respective interrupt status latches, but the CPU will not directly service them.

Operand	Binary Code								Operation Notation
–	1	1	1	1	1	1	1	0	IME ← 0
	1	0	1	1	0	0	1	0	

**Example:** If the IME bit (bit 3 of the IPR) is logic one (e.g., all instructions are enabled), the instruction DI sets the IME bit to logic zero, disabling all interrupts.

www.DataSheet4U.com

## EI — Enable Interrupts

EI

Operation:	Operand	Operation Summary	Bytes	Cycles
	–	Enable all interrupts	2	2

**Description:** Bit 3 of the interrupt priority register IPR (IME) is set to logic one. This allows all interrupts to be serviced when they occur, assuming they are enabled. If an interrupt's status latch was previously enabled by an interrupt, this interrupt can also be serviced.

Operand	Binary Code								Operation Notation
–	1	1	1	1	1	1	1	1	IME ← 1
	1	0	1	1	0	0	1	0	

**Example:** If the IME bit (bit 3 of the IPR) is logic zero (e.g., all instructions are disabled), the instruction EI sets the IME bit to logic one, enabling all interrupts.

www.DataSheet4U.com

## IDLE — Idle Operation

### IDLE

Operation:	Operand	Operation Summary	Bytes	Cycles
	–	Engage CPU idle mode	2	2

**Description:** IDLE causes the CPU clock to stop while the system clock continues oscillating by setting bit 2 of the power control register (PCON). After an IDLE instruction has been executed, peripheral hardware remains operative.

In application programs, an IDLE instruction must be immediately followed by at least three NOP instructions. This ensures an adequate time interval for the clock to stabilize before the next instruction is executed. If three NOP instructions are not used after IDLE instruction, leakage current could be flown because of the floating state in the internal bus.

Operand	Binary Code								Operation Notation
–	1	1	1	1	1	1	1	1	PCON.2 ← 1
	1	0	1	0	0	0	1	1	

**Example:** The instruction sequence

```
IDLE
NOP
NOP
NOP
```

sets bit 2 of the PCON register to logic one, stopping the CPU clock. The three NOP instructions provide the necessary timing delay for clock stabilization before the next instruction in the program sequence is executed.

# INCS — Increment and Skip on Carry

INCS          dst

Operation:	Operand	Operation Summary	Bytes	Cycles
	R	Increment register (R); skip on carry	1	1 + S
	DA	Increment direct data memory; skip on carry	2	2 + S
	@HL	Increment indirect data memory; skip on carry	2	2 + S
	RRb	Increment register pair (RRb); skip on carry	1	1 + S

**Description:** The instruction INCS increments the value of the destination operand by one. An original value of 0FH will, for example, overflow to 00H. If a carry occurs, the next instruction is skipped. The carry flag value is unaffected.

Operand	Binary Code								Operation Notation
R	0	1	0	1	1	r2	r1	r0	$R \leftarrow R + 1$ ; skip on carry
DA	1	1	0	0	1	0	1	0	$DA \leftarrow DA + 1$ ; skip on carry
	a7	a6	a5	a4	a3	a2	a1	a0	
@HL	1	1	0	1	1	1	0	1	$(HL) \leftarrow (HL) + 1$ ; skip on carry
	0	1	1	0	0	0	1	0	
RRb	1	0	0	0	0	r2	r1	0	$RRb \leftarrow RRb + 1$ ; skip on carry

**Example:** Register pair HL contains the value 7EH (01111110B). RAM location 7EH contains 0FH. The instruction sequence

```
INCS    @HL                ; 7EH ← "0"
INCS    HL                  ; Skip
INCS    @HL                ; 7EH ← "1"
```

leaves the register pair HL with the value 7EH and RAM location 7EH with the value 1H. Since a carry occurred, the second instruction is skipped. The carry flag value remains unchanged.

## IRET — Return From Interrupt

### IRET

Operation:	Operand	Operation Summary	Bytes	Cycles
	–	Return from interrupt	1	3

**Description:** IRET is used at the end of an interrupt service routine. It pops the PC values successively from the stack and restores them to the program counter. The stack pointer is incremented by six and the PSW, enable memory bank (EMB) bit, and enable register bank (ERB) bit are also automatically restored to their pre-interrupt values. Program execution continues from the resulting address, which is generally the instruction immediately after the point at which the interrupt request was detected. If a lower-level or same-level interrupt was pending when the IRET was executed, IRET will be executed before the pending interrupt is processed.

Operand	Binary Code								Operation Notation
–	1	1	0	1	0	1	0	1	$PC_{11-8} \leftarrow (SP + 1)$ (SP) $PC_{7-0} \leftarrow SP + 2)$ (SP + 3) $PSW \leftarrow (SP + 4)$ (SP + 5) $SP \leftarrow SP + 6$

**Example:** The stack pointer contains the value 0FAH. An interrupt is detected in the instruction at location 0122H. RAM locations 0FDH, 0FCH, and 0FAH contain the values 2H, 3H, and 1H, respectively. The instruction

IRET

leaves the stack pointer with the value 00H and the program returns to continue execution at location 123H.

During a return from interrupt, data is popped from the stack to the program counter. The data in stack locations 0FFH–0FAH is organized as follows:

0FAH	PC11 – PC8			
0FBH	0	0	0	0
0FCH	PC3 – PC0			
0FDH	PC7 – PC4			
0FEH	IS1	IS0	EMB	ERB
0FFH	C	SC2	SC1	SC0

## JP — Jump

JP           dst

Operation:	Operand	Operation Summary	Bytes	Cycles
	ADR12	Jump to direct address (12 bits)	3	3

**Description:** JP causes an unconditional branch to the indicated address by replacing the contents of the program counter with the address specified in the destination operand. The destination can be anywhere in the 4-Kbyte program memory address space.

Operand	Binary Code								Operation Notation
ADR12	1	1	0	1	1	0	1	1	PC11-0 ← ADR12
	0	0	0	0	a11	a10	a9	a8	
	a7	a6	a5	a4	a3	a2	a1	a0	

**Example:** The label 'SYSICON' is assigned to the instruction at program location 07FFH. The instruction  
 JP       SYSICON  
 at location 0123H will load the program counter with the value 07FFH.

## JPS — Jump (Short)

**JPS**          dst

Operation:	Operand	Operation Summary	Bytes	Cycles
	ADR12	Jump direct in page (12 bits)	2	2

**Description:** JPS causes an unconditional branch to the indicated address with the 4-Kbyte program memory address space. Bits 0–11 of the program counter are replaced with the directly specified address. The destination address for this jump is specified to the assembler by a label or by an actual address in program memory.

Operand	Binary Code								Operation Notation
ADR12	1	0	0	1	a11	a10	a9	a8	PC11–0 ← ADR12
	a7	a6	a5	a4	a3	a2	a1	a0	

**Example:** The label 'SUB' is assigned to the instruction at program memory location 00FFH. The instruction

```
JPS    SUB
```

at location 0EABH will load the program counter with the value 00FFH.

www.DataSheet4U.com



## JR — Jump Relative (Very Short)

JR dst

Operation:	Operand	Operation Summary	Bytes	Cycles
	#im	Branch to relative immediate address	1	2
	@WX	Branch relative to contents of WX register	2	3
	@EA	Branch relative to contents of EA	2	3

**Description:** JR causes the relative address to be added to the program counter and passes control to the instruction whose address is now in the PC. The range of the relative address is current PC – 15 to current PC + 16. The destination address for this jump is specified to the assembler by a label, an actual address, or by immediate data using a plus sign (+) or a minus sign (–).

For immediate addressing, the (+) range is from 2 to 16 and the (–) range is from –1 to –15. If a 0, 1, or any other number that is outside these ranges are used, the assembler interprets it as an error.

For JR @WX and JR @EA branch relative instructions, the valid range for the relative address is 0H–0FFH. The destination address for these jumps can be specified to the assembler by a label that lies anywhere within the current 256-byte block.

Normally, the 'JR @WX' and 'JR @EA' instructions jump to the address in the page in which the instruction is located. However, if the first byte of the instruction code is located at address 0xFEH or 0xFFH, the instruction will jump to the next page.

Operand	Binary Code								Operation Notation
#im *									PC11–0 ← ADR (PC–15 to PC+16)
@WX	1	1	0	1	1	1	0	1	PC11–0 ← PC11–8 + (WX)
	0	1	1	0	0	1	0	0	
@EA	1	1	0	1	1	1	0	1	PC11–0 ← PC11–8 + (EA)
	0	1	1	0	0	0	0	0	

	First Byte								Condition
* JR #im	0	0	0	1	a3	a2	a1	a0	PC ← PC+2 to PC+16
	0	0	0	0	a3	a2	a1	a0	PC ← PC–1 to PC–15

## JR — Jump Relative (Very Short)

JR (Continued)

**Examples:** 1. A short form for a relative jump to label 'KK' is the instruction

```
JR KK
```

where 'KK' must be within the allowed range of current PC-15 to current PC+16. The JR instruction has in this case the effect of an unconditional JP instruction.

2. In the following instruction sequence, if the instruction 'LD WX, #02H' were to be executed in place of 'LD WX,#00H', the program would jump to 0502H and 'JPS BBB' would be executed. If 'LD EA,#04H' were to be executed, the jump would be to 0504H and 'JPS CCC' would be executed.

```
ORG 0500H

JPS AAA
JPS BBB
JPS CCC
JPS DDD

LD WX,#00H ; WX ← 00H
LD EA,WX
ADS WX,EA ; WX ← (WX) + (WX)
JR @WX ; Current PC11-8 (05H) + WX (00H) = 0500H
; Jump to address 0500H and execute JPS AAA
```

3. Here is another example:

```
ORG 0600H

LD A,#0H
LD A,#1H
LD A,#2H
LD A,#3H
LD 30H,A ; Address 30H ← A
JPS YYY

XXX LD EA,#00H ; EA ← 00H
JR @EA ; Jump to address 0600H
; Address 30H ← 0H
```

If 'LD EA,#01H' were to be executed in place of 'LD EA,#00H', the program would jump to 0601H and address 30H would contain the value 1H. If 'LD EA,#02H' were to be executed, the jump would be to 0602H and address 30H would contain the value 2H.

## LD — Load

LD dst,src

Operation:	Operand	Operation Summary	Bytes	Cycles
	A,#im	Load 4-bit immediate data to A	1	1
	A,@RRa	Load indirect data memory contents to A	1	1
	A,DA	Load direct data memory contents to A	2	2
	A,Ra	Load register contents to A	2	2
	Ra,#im	Load 4-bit immediate data to register	2	2
	RR,#imm	Load 8-bit immediate data to register	2	2
	DA,A	Load contents of A to direct data memory	2	2
	Ra,A	Load contents of A to register	2	2
	EA,@HL	Load indirect data memory contents to EA	2	2
	EA,DA	Load direct data memory contents to EA	2	2
	EA,RRb	Load register contents to EA	2	2
	@HL,A	Load contents of A to indirect data memory	1	1
	DA,EA	Load contents of EA to data memory	2	2
	RRb,EA	Load contents of EA to register	2	2
	@HL,EA	Load contents of EA to indirect data memory	2	2

**Description:** The contents of the source are loaded into the destination. The source's contents are unaffected.

If an instruction such as 'LD A,#im' (LD EA,#imm) or 'LD HL,#imm' is written more than two times in succession, only the first LD will be executed; the other similar instructions that immediately follow the first LD will be treated like a NOP. This is called the 'redundancy effect' (see examples below).

Operand	Binary Code								Operation Notation
A,#im	1	0	1	1	d3	d2	d1	d0	A ← im
A,@RRa	1	0	0	0	1	i2	i1	i0	A ← (RRa)
A,DA	1	0	0	0	1	1	0	0	A ← DA
	a7	a6	a5	a4	a3	a2	a1	a0	
A,Ra	1	1	0	1	1	1	0	1	A ← Ra
	0	0	0	0	1	r2	r1	r0	
Ra,#im	1	1	0	1	1	0	0	1	Ra ← im
	d3	d2	d1	d0	1	r2	r1	r0	

# LD — Load

LD (Continued)

Description:	Operand	Binary Code							Operation Notation	
RR,#imm		1	0	0	0	0	r2	r1	1	RR ← imm
		d7	d6	d5	d4	d3	d2	d1	d0	
DA,A		1	0	0	0	1	0	0	1	DA ← A
		a7	a6	a5	a4	a3	a2	a1	a0	
Ra,A		1	1	0	1	1	1	0	1	Ra ← A
		0	0	0	0	0	r2	r1	r0	
EA,@HL		1	1	0	1	1	1	0	0	A ← (HL), E ← (HL + 1)
		0	0	0	0	1	0	0	0	
EA,DA		1	1	0	0	1	1	1	0	A ← DA, E ← DA + 1
		a7	a6	a5	a4	a3	a2	a1	a0	
EA,RRb		1	1	0	1	1	1	0	0	EA ← RRb
		1	1	1	1	1	r2	r1	0	
@HL,A		1	1	0	0	0	1	0	0	(HL) ← A
DA,EA		1	1	0	0	1	1	0	1	DA ← A, DA + 1 ← E
		a7	a6	a5	a4	a3	a2	a1	a0	
RRb,EA		1	1	0	1	1	1	0	0	RRb ← EA
		1	1	1	1	0	r2	r1	0	
@HL,EA		1	1	0	1	1	1	0	0	(HL) ← A, (HL + 1) ← E
		0	0	0	0	0	0	0	0	

### Examples:

- RAM location 30H contains the value 4H. The RAM location values are 40H, 41H, and 0AH, 3H respectively. The following instruction sequence leaves the value 40H in point pair HL, 0AH in the accumulator and in RAM location 40H, and 3H in register E.

```
LD    HL,#30H           ; HL ← 30H
LD    A,@HL            ; A ← 4H
LD    HL,#40H          ; HL ← 40H
LD    EA,@HL           ; A ← 0AH, E ← 3H
LD    @HL,A            ; RAM (40H) ← 0AH
```

## LD — Load

**LD** (Continued)

**Examples:** 2. If an instruction such as LD A,#im (LD EA,#imm) or LD HL,#imm is written more than two times in succession, only the first LD is executed; the next instructions are treated as NOPs. Here are two examples of this 'redundancy effect':

```
LD A,#1H           ; A ← 1H
LD EA,#2H          ; NOP
LD A,#3H           ; NOP
LD 23H,A           ; (23H) ← 1H

LD HL,#10H         ; HL ← 10H
LD HL,#20H         ; NOP
LD A,#3H           ; A ← 3H
LD EA,#35          ; NOP
LD @HL,A           ; (10H) ← 3H
```

The following table contains descriptions of special characteristics of the LD instruction when used in different addressing modes:

<u>Instruction</u>	<u>Operation Description and Guidelines</u>
LD A,#im	Since the 'redundancy effect' occurs with instructions like LD EA,#imm, if this instruction is used consecutively, the second and additional instructions of the same type will be treated like NOPs.
LD A,@RRa	Load the data memory contents pointed to by 8-bit RRa register pairs (HL, WX, WL) to the A register.
LD A,DA	Load direct data memory contents to the A register.
LD A,Ra	Load 4-bit register Ra (E, L, H, X, W, Z, Y) to the A register.
LD Ra,#im	Load 4-bit immediate data into the Ra register (E, L, H, X, W, Y, Z).
LD RR,#imm	Load 8-bit immediate data into the Ra register (EA, HL, WX, YZ). There is a redundancy effect if the operation addresses the HL or EA registers.
LD DA,A	Load contents of register A to direct data memory address.
LD Ra,A	Load contents of register A to 4-bit Ra register (E, L, H, X, W, Z, Y).

## LD — Load

LD (Concluded)

Examples:	<u>Instruction</u>	<u>Operation Description and Guidelines</u>
	LD EA,@HL	Load data memory contents pointed to by 8-bit register HL to the A register, and the contents of HL+1 to the E register. The contents of register L must be an even number. If the number is odd, the LSB of register L is recognized as a logic zero (an even number), and it is not replaced with the true value. For example, 'LD HL,#36H' loads immediate 36H to HL and the next instruction 'LD EA,@HL' loads the contents of 36H to register A and the contents of 37H to register E.
	LD EA,DA	Load direct data memory contents of DA to the A register, and the next direct data memory contents of DA + 1 to the E register. The DA value must be an even number. If it is an odd number, the LSB of DA is recognized as a logic zero (an even number), and it is not replaced with the true value. For example, 'LD EA,37H' loads the contents of 36H to the A register and the contents of 37H to the E register.
	LD EA,RRb	Load 8-bit RRb register (HL, WX, YZ) to the EA register. H, W, and Y register values are loaded into the E register, and the L, X, and Z values into the A register.
	LD @HL,A	Load A register contents to data memory location pointed to by the 8-bit HL register value.
	LD DA,EA	Load the A register contents to direct data memory and the E register contents to the next direct data memory location. The DA value must be an even number. If it is an odd number, the LSB of the DA value is recognized as logic zero (an even number), and is not replaced with the true value.
	LD RRb,EA	Load contents of EA to the 8-bit RRb register (HL, WX, YZ). The E register is loaded into the H, W, and Y register and the A register into the L, X, and Z register.
	LD @HL,EA	Load the A register to data memory location pointed to by the 8-bit HL register, and the E register contents to the next location, HL + 1. The contents of the L register must be an even number. If the number is odd, the LSB of the L register is recognized as logic zero (an even number), and is not replaced with the true value. For example, 'LD HL,#36H' loads immediate 36H to register HL; the instruction 'LD @HL,EA' loads the contents of A into address 36H and the contents of E into address 37H.

## LDB — Load Bit

**LDB** dst,src.b

**LDB** dst.b,src

Operation:	Operand	Operation Summary	Bytes	Cycles
	mema.b,C	Load carry bit to a specified memory bit	2	2
	memb.@L,C	Load carry bit to a specified indirect memory bit	2	2
	@H+DA.b,C		2	2
	C,mema.b	Load memory bit to a specified carry bit	2	2
	C,memb.@L	Load indirect memory bit to a specified carry bit	2	2
	C,@H+DA.b		2	2

**Description:** The Boolean variable indicated by the first or second operand is copied into the location specified by the second or first operand. One of the operands must be the carry flag; the other may be any directly or indirectly addressable bit. The source is unaffected.

Operand	Binary Code								Operation Notation
mema.b,C *	1	1	1	1	1	1	0	0	mema.b ← C
memb.@L,C	1	1	1	1	1	1	0	0	memb.7–2 + [L.3–2]. [L.1–0] ← C
	0	1	0	0	a5	a4	a3	a2	
@H+DA.b,C	1	1	1	1	1	1	0	0	H + [DA.3–0].b ← (C)
	0	b2	b1	b0	a3	a2	a1	a0	
C,mema.b*	1	1	1	1	0	1	0	0	C ← mema.b
C,memb.@L	1	1	1	1	0	1	0	0	C ← memb.7–2 + [L.3–2] . [L.1–0]
	0	1	0	0	a5	a4	a3	a2	
C,@H+DA.b	1	1	1	1	0	1	0	0	C ← [H + DA.3–0].b
	0	b2	b1	b0	a3	a2	a1	a0	

		Second Byte						Bit Addresses		
*	mema.b	1	0	b1	b0	a3	a2	a1	a0	FB0H–FBFH
		1	1	b1	b0	a3	a2	a1	a0	FF1H–FF9H

## LDB — Load Bit

**LDB** (Continued)

**Examples:** 1. The carry flag is set and the data value at input pin P1.0 is logic zero. The following instruction clears the carry flag to logic zero.

```
LDB      C,P1.0
```

2. The P1 address is FF1H and the L register contains the value 9H (1001B). The address (memb.7–2) is 111100B and (L.3–2) is 10B. The resulting address is 11110010B or FF2H and P2 is addressed. The bit value (L.1–0) is specified as 01B (bit 1).

```
LD       L,#9H
LDB     C,P1.@L      ; P1.@L specifies P2.1 and C ← P2.1
```

3. The H register contains the value 2H and FLAG = 20H.3. The address for H is 0010B and for FLAG(3–0) the address is 0000B. The resulting address is 00100000B or 20H. The bit value is 3. Therefore, @H+FLAG = 20H.3.

```
FLAG    EQU  20H.3
LD      H,#2H
LDB     C,@H+FLAG  ; C ← FLAG (20H.3)
```

4. The following instruction sequence sets the carry flag and the loads the "1" data value to the output pin P2.0, setting it to output mode:

```
SCF                                ; C ← "1"
LDB     P2.0,C                      ; P2.0 ← "1"
```

5. The P1 address is FF1H and L = 9H (1001B). The address (memb.7–2) is 111100B and (L.3–2) is 10B. The resulting address, 11110010B specifies P2. The bit value (L.1–0) is specified as 01B (bit 1). Therefore, P1.@L = P2.1.

```
SCF                                ; C ← "1"
LD      L,#9H
LDB     P1.@L,C                    ; P1.@L specifies P2.1
                                           ; P2.1 ← "1"
```

6. In this example, H = 2H and FLAG = 20H.3 and the address 20H is specified. Since the bit value is 3, @H+FLAG = 20H.3:

```
FLAG    EQU  20H.3
RCF                                ; C ← "0"
LD      H,#2H
LDB     @H+FLAG,C                  ; FLAG(20H.3) ← "0"
```

**NOTE:** Port pin names used in examples 4 and 5 may vary with different SAM47 devices.



## LDC — Load Code Byte

**LDC** dst,src

Operation:	Operand	Operation Summary	Bytes	Cycles
	EA,@WX	Load code byte from WX to EA	1	3
	EA,@EA	Load code byte from EA to EA	1	3

**Description:** This instruction is used to load a byte from program memory into an extended accumulator. The address of the byte fetched is the five highest bit values in the program counter and the contents of an 8-bit working register (either WX or EA). The contents of the source are unaffected.

Operand	Binary Code								Operation Notation
EA,@WX	1	1	0	0	1	1	0	0	$EA \leftarrow [PC11-8 + (WX)]$
EA,@EA	1	1	0	0	1	0	0	0	$EA \leftarrow [PC11-8 + (EA)]$

**Examples:** 1. The following instructions will load one of four values defined by the define byte (DB) directive to the extended accumulator:

```

LD    EA,#00H
CALL  DISPLAY
JPS   MAIN

ORG   0500H

DB    66H
DB    77H
DB    88H
DB    99H
•
•
•
DISPLAY LDC  EA,@EA    ; EA ← address 0500H = 66H
RET

```

If the instruction 'LD EA,#01H' is executed in place of 'LD EA,#00H', The content of 0501H (77H) is loaded to the EA register. If 'LD EA,#02H' is executed, the content of address 0502H (88H) is loaded to EA.

# LDC — Load Code Byte

**LDC** (Continued)

**Examples:** 2. The following instructions will load one of four values defined by the define byte (DB) directive to the extended accumulator:

```

                ORG    0500

                DB     66H
                DB     77H
                DB     88H
                DB     99H
                .
                .
                .
DISPLAY LD     WX,#00H
                LDC   EA,@WX    ; EA ← address 0500H = 66H
                RET

```

If the instruction 'LD WX,#01H' is executed in place of 'LD WX,#00H', then  
EA ← address 0501H = 77H.

If the instruction 'LD WX,#02H' is executed in place of 'LD WX,#00H', then  
EA ← address 0502H = 88H.

3. Normally, the LDC EA, @EA and the LDC EA, @WX instructions reference the table data on the page on which the instruction is located. If, however, the instruction is located at address xxFFH, it will reference table data on the next page. In this example, the upper 4 bits of the address at location 0200H is loaded into register E and the lower 4 bits into register A:

```

                ORG    01FDH

01FDH    LD     WX,#00H
01FFH    LDC   EA,@WX    ;      E ← upper 4 bits of 0200H address
                ;      A ← lower 4 bits of 0200H address

```

4. Here is another example of page referencing with the LDC instruction:

```

                ORG    0100

                DB     67H
                SMB    0
                LD     HL,#30H ;      Even number
                LD     WX,#00H
                LDC   EA,@WX ;      E ← upper 4 bits of 0100H address
                ;      A ← lower 4 bits of 0100H address
                LD     @HL,EA ;      RAM (30H) ← 7, RAM (31H) ← 6

```

## LDD — Load Data Memory and Decrement

**LDD** dst

Operation:	Operand	Operation Summary	Bytes	Cycles
	A,@HL	Load indirect data memory contents to A; decrement register L contents and skip on borrow	1	2 + S

**Description:** The contents of a data memory location are loaded into the accumulator, and the contents of the register L are decreased by one. If a "borrow" occurs (e.g., if the resulting value in register L is 0FH), the next instruction is skipped. The contents of data memory and the carry flag value are not affected.

Operand	Binary Code								Operation Notation
A,@HL	1	0	0	0	1	0	1	1	$A \leftarrow (HL)$ , then $L \leftarrow L-1$ ; skip if $L = 0FH$

**Example:** In this example, assume that register pair HL contains 20H and internal RAM location 20H contains the value 0FH:

```
LD    HL,#20H
LDD   A,@HL      ; A ← (HL) and L ← L-1
JPS   XXX        ; Skip
JPS   YYY        ; H ← 2H and L ← 0FH
```

The instruction 'JPS XXX' is skipped since a "borrow" occurred after the 'LDD A,@HL' and instruction 'JPS YYY' is executed.

## LDI — Load Data Memory and Increment

**LDI** dst,src

Operation:	Operand	Operation Summary	Bytes	Cycles
	A,@HL	Load indirect data memory to A; increment register L contents and skip on overflow	1	2 + S

**Description:** The contents of a data memory location are loaded into the accumulator, and the contents of the register L are incremented by one. If an overflow occurs (e.g., if the resulting value in register L is 0H), the next instruction is skipped. The contents of data memory and the carry flag value are not affected.

Operand	Binary Code								Operation Notation
A,@HL	1	0	0	0	1	0	1	0	$A \leftarrow (HL)$ , then $L \leftarrow L+1$ ; skip if $L = 0H$

**Example:** Assume that register pair HL contains the address 2FH and internal RAM location 2FH contains the value 0FH:

```
LD    HL,#2FH
LDI   A,@HL      ; A ← (HL) and L ← L+1
JPS   XXX        ; Skip
JPS   YYY        ; H ← 2H and L ← 0H
```

The instruction 'JPS XXX' is skipped since an overflow occurred after the 'LDI A,@HL' and the instruction 'JPS YYY' is executed.



# NOP — No Operation

## NOP

Operation:	Operand	Operation Summary	Bytes	Cycles
	–	No operation	1	1

**Description:** No operation is performed by a NOP instruction. It is typically used for timing delays.

One NOP causes a 1-cycle delay: with a 1  $\mu$ s cycle time, five NOPs would therefore cause a 5  $\mu$ s delay. Program execution continues with the instruction immediately following the NOP. Only the PC is affected. At least three NOP instructions should follow a STOP or IDLE instruction.

Operand	Binary Code								Operation Notation
–	1	0	1	0	0	0	0	0	No operation

**Example:** Three NOP instructions follow the STOP instruction to provide a short interval for clock stabilization before power-down mode is initiated:

```
STOP
NOP
NOP
NOP
```

www.DataSheet4U.com

## OR — Logical OR

OR            dst,src

Operation:	Operand	Operation Summary	Bytes	Cycles
	A, #im	Logical-OR immediate data to A	2	2
	A, @HL	Logical-OR indirect data memory contents to A	1	1
	EA,RR	Logical-OR double register to EA	2	2
	RRb,EA	Logical-OR EA to double register	2	2

**Description:** The source operand is logically ORed with the destination operand. The result is stored in the destination. The contents of the source are unaffected.

Operand	Binary Code								Operation Notation
A, #im	1	1	0	1	1	1	0	1	A ← A OR im
	0	0	1	0	d3	d2	d1	d0	
A, @HL	0	0	1	1	1	0	1	0	A ← A OR (HL)
EA,RR	1	1	0	1	1	1	0	0	EA ← EA OR RR
	0	0	1	0	1	r2	r1	0	
RRb,EA	1	1	0	1	1	1	0	0	RRb ← RRb OR EA
	0	0	1	0	0	r2	r1	0	

**Example:** If the accumulator contains the value 0C3H (11000011B) and register pair HL the value 55H (01010101B), the instruction

OR        EA,@HL

leaves the value 0D7H (11010111B) in the accumulator .

# POP — Pop From Stack

POP            dst

Operation:	Operand	Operation Summary	Bytes	Cycles
	RR	Pop to register pair from stack	1	1
	SB	Pop SMB and SRB values from stack	2	2

**Description:** The contents of the RAM location addressed by the stack pointer is read, and the SP is incremented by two. The value read is then transferred to the variable indicated by the destination operand.

Operand	Binary Code								Operation Notation
RR	0	0	1	0	1	r2	r1	0	$RR_L \leftarrow (SP), RR_H \leftarrow (SP+1)$ $SP \leftarrow SP+2$
SB	1	1	0	1	1	1	0	1	$(SRB) \leftarrow (SP), SMB \leftarrow (SP+1),$ $SP \leftarrow SP+2$
	0	1	1	0	0	1	1	0	

**Example:** The SP value is equal to 0EDH, and RAM locations 0EFH through 0EDH contain the values 2H, 3H, and 4H, respectively. The instruction

```
POP HL
```

leaves the stack pointer set to 0EFH and the data pointer pair HL set to 34H.

# PUSH — Push Onto Stack

**PUSH**      src

Operation:	Operand	Operation Summary	Bytes	Cycles
	RR	Push register pair onto stack	1	1
	SB	Push SMB and SRB values onto stack	2	2

**Description:** The SP is then decreased by two and the contents of the source operand are copied into the RAM location addressed by the stack pointer, thereby adding a new element to the top of the stack.

Operand	Binary Code								Operation Notation
RR	0	0	1	0	1	r2	r1	1	$(SP-1) \leftarrow RR_H, (SP-2) \leftarrow RR_L$ $SP \leftarrow SP-2$
SB	1	1	0	1	1	1	0	1	$(SP-1) \leftarrow SMB, (SP-2) \leftarrow SRB;$ $(SP) \leftarrow SP-2$
	0	1	1	0	0	1	1	1	

**Example:** As an interrupt service routine begins, the stack pointer contains the value 0FAH and the data pointer register pair HL contains the value 20H. The instruction

```
PUSH    HL
```

leaves the stack pointer set to 0F8H and stores the values 2H and 0H in RAM locations 0F9H and 0F8H, respectively.



## RCF — Reset Carry Flag

### RCF

Operation:	Operand	Operation Summary	Bytes	Cycles
	–	Reset carry flag to logic zero	1	1

**Description:** The carry flag is cleared to logic zero, regardless of its previous value.

Operand	Binary Code								Operation Notation
–	1	1	1	0	0	1	1	0	$C \leftarrow 0$

**Example:** Assuming the carry flag is set to logic one, the instruction

RCF

resets (clears) the carry flag to logic zero.

www.DataSheet4U.com

## REF — Reference Instruction

REF            dst

Operation:	Operand	Operation Summary	Bytes	Cycles
	memc	Reference code	1	3 *

\* The REF instruction for a 16K CALL instruction is 4 cycles.

**Description:** The REF instruction is used to rewrite into 1-byte form, arbitrary 2-byte or 3-byte instructions (or two 1-byte instructions) stored in the REF instruction reference area in program memory. REF reduces the number of program memory accesses for a program.

Operand	Binary Code								Operation Notation
memc	t7	t6	t5	t4	t3	t2	t1	t0	PC11-0 = memc7-4, memc3-0 < 1

TJP and TCALL are 2-byte pseudo-instructions that are used only to specify the reference area:

- When the reference area is specified by the TJP instruction,  
 $\text{memc.7-6} = 00$   
 $\text{PC11-0} \leftarrow \text{memc.3-0} + (\text{memc} + 1)$
- When the reference area is specified by the TCALL instruction,  
 $\text{memc.7-6} = 01$   
 $(\text{SP-4}) (\text{SP-1}) (\text{SP-2}) \leftarrow \text{PC11-0}$   
 $\text{SP-3} \leftarrow \text{EMB, ERB, 0, 0}$   
 $\text{PC11-0} \leftarrow \text{memc.3-0} + (\text{memc} + 1)$   
 $\text{SP} \leftarrow \text{SP-4}$

When the reference area is specified by any other instruction, the 'memc' and 'memc + 1' instructions are executed.

Instructions referenced by REF occupy 2 bytes of memory space (for two 1-byte instructions or one 2-byte instruction) and must be written as an even number from 0020H to 007FH in ROM. In addition, the destination address of the TJP and TCALL instructions must be located with the 0FFFH address. TJP and TCALL are reference instructions for JP/JPS and CALL/CALLS.

If the instruction following a REF is subject to the 'redundancy effect', the redundant instruction is skipped. If, however, the REF follows a redundant instruction, it is executed.

On the other hand, the binary code of a REF instruction is 1 byte. The upper 4 bits become the higher address bits of the referenced instruction, and the lower 4 bits of the referenced instruction (  $\times 1/2$  ) becomes the lower address, producing a total of 8 bits or 1 byte (see Example 3 below).

## REF — Reference Instruction

REF (Continued)

**Examples:** 1. Instructions can be executed efficiently using REF, as shown in the following example:

```

    ORG 0020H

AAA   LD    HL,#00H
BBB   LD    EA,#FFH
CCC   TCALL SUB1
DDD   TJP   SUB2
    .
    .
    .
    ORG 0080H

REF   AAA           ; LD    HL,#00H
REF   BBB           ; LD    EA,#FFH
REF   CCC           ; CALL  SUB1
REF   DDD           ; JP    SUB2

```

2. The following example shows how the REF instruction is executed in relation to LD instructions that have a 'redundancy effect':

```

    ORG 0020H
AAA   LD    EA,#40H
    .
    .
    .
    ORG 0100H

LD    EA,#30H
REF   AAA           ; Not skipped
    .
    .

REF   AAA
LD    EA,#50H       ; Skipped
SRB   2

```

## REF — Reference Instruction

REF (Concluded)

**Examples:** 3. In this example the binary code of 'REF A1' at locations 20H–21H is 20H, for 'REF A2' at locations 22H–23H, it is 21H, and for 'REF A3' at 24H–25H, the binary code is 22H :

<u>Opcode</u>	<u>Symbol</u>	<u>Instruction</u>			
		ORG	0020H		
83	00	A1	LD	HL,#00H	
83	03	A2	LD	HL,#03H	
83	05	A3	LD	HL,#05H	
83	10	A4	LD	HL,#10H	
83	26	A5	LD	HL,#26H	
83	08	A6	LD	HL,#08H	
83	0F	A7	LD	HL,#0FH	
83	F0	A8	LD	HL,#0F0H	
83	67	A9	LD	HL,#067H	
41	0B	A10	TCALL	SUB1	
01	0D	A11	TJP	SUB2	
			•		
			•		
			•		
		ORG	0100H		
20		REF	A1	;	LD HL,#00H
21		REF	A2	;	LD HL,#03H
22		REF	A3	;	LD HL,#05H
23		REF	A4	;	LD HL,#10H
24		REF	A5	;	LD HL,#26H
25		REF	A6	;	LD HL,#08H
26		REF	A7	;	LD HL,#0FH
27		REF	A8	;	LD HL,#0F0H
30		REF	A9	;	LD HL,#067H
31		REF	A10	;	CALL SUB1
32		REF	A11	;	JP SUB2

# RET — Return From Subroutine

## RET

Operation:	Operand	Operation Summary	Bytes	Cycles
	–	Return from subroutine	1	3

**Description:** RET pops the PC values successively from the stack, incrementing the stack pointer by six. Program execution continues from the resulting address, generally the instruction immediately following a CALL or CALLS.

Operand	Binary Code								Operation Notation
–	1	1	0	0	0	1	0	1	PC11–8 ← (SP+1) (SP) PC7–0 ← (SP+2) (SP+3) PSW ← EMB,ERB SP ← SP+ 6

**Example:** The stack pointer contains the value 0FAH. RAM locations 0FAH, 0FBH, 0FCH, and 0FDH contain 1H, 0H, 5H, and 2H, respectively. The instruction

RET

leaves the stack pointer with the new value of 00H and program execution continues from location 0125H.

During a return from subroutine, PC values are popped from stack locations as follows:

SP →	PC11 – PC8			
SP + 1	0	0	0	0
SP + 2	PC3 – PC0			
SP + 3	PC7 – PC4			
SP + 4	0	0	EMB	ERB
SP + 5	0	0	0	0
SP + 6				

## RRC — Rotate Accumulator Right Through Carry

RRC A

Operation:	Operand	Operation Summary	Bytes	Cycles
	A	Rotate right through carry bit	1	1

**Description:** The four bits in the accumulator and the carry flag are together rotated one bit to the right. Bit 0 moves into the carry flag and the original carry value moves into the bit 3 accumulator position.

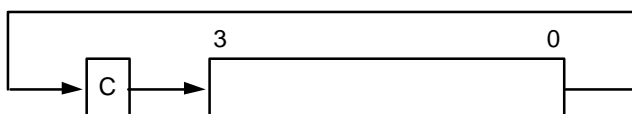

Operand	Binary Code								Operation Notation
A	1	0	0	0	1	0	0	0	$C \leftarrow A.0, A3 \leftarrow C$ $A.n-1 \leftarrow A.n \quad (n = 1, 2, 3)$

**Example:** The accumulator contains the value 5H (0101B) and the carry flag is cleared to logic zero. The instruction

RRC A

leaves the accumulator with the value 2H (0010B) and the carry flag set to logic one.

## SBC — Subtract With Carry

**SBC** dst,src

Operation:	Operand	Operation Summary	Bytes	Cycles
	A,@HL	Subtract indirect data memory from A with carry	1	1
	EA,RR	Subtract register pair (RR) from EA with carry	2	2
	RRb,EA	Subtract EA from register pair (RRb) with carry	2	2

**Description:** SBC subtracts the source and carry flag value from the destination operand, leaving the result in the destination. SBC sets the carry flag if a borrow is needed for the most significant bit; otherwise it clears the carry flag. The contents of the source are unaffected.

If the carry flag was set before the SBC instruction was executed, a borrow was needed for the previous step in multiple precision subtraction. In this case, the carry bit is subtracted from the destination along with the source operand.

Operand	Binary Code								Operation Notation
A,@HL	0	0	1	1	1	1	0	0	$C, A \leftarrow A - (HL) - C$
EA,RR	1	1	0	1	1	1	0	0	$C, EA \leftarrow EA - RR - C$
	1	1	0	0	1	r2	r1	0	
RRb,EA	1	1	0	1	1	1	0	0	$C, RRb \leftarrow RRb - EA - C$
	1	1	0	0	0	r2	r1	0	

**Examples:**

1. The extended accumulator contains the value 0C3H, register pair HL the value 0AAH, and the carry flag is set to "1":

```
SCF                ; C ← "1"
SBC    EA,HL        ; EA ← 0C3H - 0AAH - 1H, C ← "0"
JPS    XXX          ; Jump to XXX; no skip after SBC
```

2. If the extended accumulator contains the value 0C3H, register pair HL the value 0AAH, and the carry flag is cleared to "0":

```
RCF                ; C ← "0"
SBC    EA,HL        ; EA ← 0C3H - 0AAH - 0H = 19H, C ← "0"
JPS    XXX          ; Jump to XXX; no skip after SBC
```

## SBC — Subtract With Carry

**SBC** (Continued)

**Examples:** 3. If SBC A,@HL is followed by an ADS A,#im, the SBC skips on 'no borrow' to the instruction immediately after the ADS. An 'ADS A,#im' instruction immediately after the 'SBC A,@HL' instruction does not skip even if an overflow occurs. This function is useful for decimal adjustment operations.

a. 8 – 6 decimal addition (the contents of the address specified by the HL register is 6H):

```
RCF                ; C ← "0"
LD      A,#8H      ; A ← 8H
SBC     A,@HL      ; A ← 8H – 6H – C(0) = 2H, C ← "0"
ADS     A,#0AH     ; Skip this instruction because no borrow after SBC result
JPS     XXX
```

b. 3 – 4 decimal addition (the contents of the address specified by the HL register is 4H):

```
RCF                ; C ← "0"
LD      A,#3H      ; A ← 3H
SBC     A,@HL      ; A ← 3H – 4H – C(0) = 0FH, C ← "1"
ADS     A,#0AH     ; No skip. A ← 0FH + 0AH = 9H
                ; (The skip function of 'ADS A,#im' is inhibited after a
                ; 'SBC A,@HL' instruction even if an overflow occurs.)
JPS     XXX
```



## SBS — Subtract

**SBS** dst,src

Operation:	Operand	Operation Summary	Bytes	Cycles
	A,@HL	Subtract indirect data memory from A; skip on borrow	1	1 + S
	EA,RR	Subtract register pair (RR) from EA; skip on borrow	2	2 + S
	RRb,EA	Subtract EA from register pair (RRb); skip on borrow	2	2 + S

**Description:** The source operand is subtracted from the destination operand and the result is stored in the destination. The contents of the source are unaffected. A skip is executed if a borrow occurs. The value of the carry flag is not affected.

Operand	Binary Code								Operation Notation
A,@HL	0	0	1	1	1	1	0	1	$A \leftarrow A - (HL)$ ; skip on borrow
EA,RR	1	1	0	1	1	1	0	0	$EA \leftarrow EA - RR$ ; skip on borrow
	1	0	1	1	1	r2	r1	0	
RRb,EA	1	1	0	1	1	1	0	0	$RRb \leftarrow RRb - EA$ ; skip on borrow
	1	0	1	1	0	r2	r1	0	

### Examples:

- The accumulator contains the value 0C3H, register pair HL contains the value 0C7H, and the carry flag is cleared to logic zero:

```
RCF                ; C ← "0"
SBS    EA,HL       ; EA ← 0C3H - 0C7H, C ← "0"
                ; SBS instruction skips on borrow,
                ; but carry flag value is not affected
JPS    XXX         ; Skip because a borrow occurred
JPS    YYY         ; Jump to YYY is executed
```

- The accumulator contains the value 0AFH, register pair HL contains the value 0AAH, and the carry flag is set to logic one:

```
SCF                ; C ← "1"
SBS    EA,HL       ; EA ← 0AFH - 0AAH, C ← "1"
JPS    XXX         ; Jump to XXX
                ; JPS was not skipped since no "borrow" occurred after SBS
```

## SCF — Set Carry Flag

### SCF

Operation:	Operand	Operation Summary	Bytes	Cycles
	–	Set carry flag to logic one	1	1

**Description:** The SCF instruction sets the carry flag to logic one, regardless of its previous value.

Operand	Binary Code								Operation Notation
–	1	1	1	0	0	1	1	1	$C \leftarrow 1$

**Example:** If the carry flag is cleared to logic zero, the instruction

SCF

sets the carry flag to logic one.

www.DataSheet4U.com



## SMB — Select Memory Bank

**SMB**      n

Operation:	Operand	Operation Summary	Bytes	Cycles
	n	Select memory bank	2	2

**Description:** The SMB instruction sets the upper four bits of a 12-bit data memory address to select a specific memory bank. The constants 0, 1, and 15 are usually used as the SMB operand to select the corresponding memory bank. All references to data memory addresses fall within the following address ranges:

Please note that since data memory spaces differ for various devices in the SAM47 product family, the 'n' value of the SMB instruction will also vary.

Addresses	Register Areas	Bank	SMB
000H–01FH	Working registers	0	0
020H–0FFH	Stack and general-purpose registers		
1E0H–1FFH	Display registers	1	1
F80H–FFFH	I/O-mapped hardware registers	15	15

The enable memory bank (EMB) flag must always be set to "1" in order for the SMB instruction to execute successfully for memory banks 0, 1, and 15.

Format	Binary Code								Operation Notation
n	1	1	0	1	1	1	0	1	SMB ← n (n = 0, 1, 15)
	0	1	0	0	d3	d2	d1	d0	

**Example:** If the EMB flag is set, the instruction

SMB 0

selects the data memory address range for bank 0 (000H–0FFH) as the working memory bank.

## SRB — Select Register Bank

SRB            n

Operation:	Operand	Operation Summary	Bytes	Cycles
	n	Select register bank	2	2

**Description:** The SRB instruction selects one of four register banks in the working register memory area. The constant value used with SRB is 0, 1, 2, or 3. The following table shows the effect of SRB settings:

ERB Setting	SRB Settings				Selected Register Bank
	3	2	1	0	
0	0	0	x	x	Always set to bank 0
1	0	0	0	0	Bank 0
			0	1	Bank 1
			1	0	Bank 2
			1	1	Bank 3

**NOTE:** 'x' = not applicable.

The enable register bank flag (ERB) must always be set for the SRB instruction to execute successfully for register banks 0, 1, 2, and 3. In addition, if the ERB value is logic zero, register bank 0 is always selected, regardless of the SRB value.

Operand	Binary Code								Operation Notation
n	1	1	0	1	1	1	0	1	SRB ← n (n = 0, 1, 2, 3)
	0	1	0	1	0	0	d1	d0	

**Example:** If the ERB flag is set, the instruction

SRB    3

selects register bank 3 (018H–01FH) as the working memory register bank.

## SRET — Return From Subroutine and Skip

### SRET

Operation:	Operand	Operation Summary	Bytes	Cycles
	–	Return from subroutine and skip	1	3 + S

**Description:** SRET is normally used to return to the previously executing procedure at the end of a subroutine that was initiated by a CALL or CALLS instruction. SRET skips the resulting address, which is generally the instruction immediately after the point at which the subroutine was called. Then, program execution continues from the resulting address and the contents of the location addressed by the stack pointer are popped into the program counter.

Operand	Binary Code								Operation Notation
–	1	1	1	0	0	1	0	1	PC11–8 ← (SP + 1) (SP) PC7–0 ← (SP + 3) (SP + 2) EMB,ERB ← (SP + 5) (SP + 4) SP ← SP + 6 then skip

**Example:** If the stack pointer contains the value 0FAH and RAM locations 0FAH, 0FBH, 0FCH, and 0FDH contain the values 1H, 0H, 5H, and 2H, respectively, the instruction

SRET

leaves the stack pointer with the value 00H and the program returns to continue execution at location 0125H. then skips unconditionally.

During a return from subroutine, data is popped from the stack to the PC as follows:

SP →	PC11 – PC8			
SP + 1	0	0	0	0
SP + 2	PC3 – PC0			
SP + 3	PC7 – PC4			
SP + 4	0	0	EMB	ERB
SP + 5	0	0	0	0
SP + 6				

# STOP — Stop Operation

## STOP

Operation:	Operand	Operation Summary	Bytes	Cycles
	–	Engage CPU stop mode	2	2

**Description:** The STOP instruction stops the system clock by setting bit 3 of the power control register (PCON) to logic one. When STOP executes, all system operations are halted with the exception of some peripheral hardware with special power-down mode operating conditions.

In application programs, a STOP instruction must be immediately followed by at least three NOP instructions. This ensures an adequate time interval for the clock to stabilize before the next instruction is executed. If three NOP instructions are not used after STOP instruction, leakage current could be flown because of the floating state in the internal bus.

Operand	Binary Code								Operation Notation
–	1	1	1	1	1	1	1	1	PCON.3 ← 1
	1	0	1	1	0	0	1	1	

**Example:** Given that bit 3 of the PCON register is cleared to logic zero, and all systems are operational, the instruction sequence

```
STOP
NOP
NOP
NOP
```

sets bit 3 of the PCON register to logic one, stopping all controller operations (with the exception of some peripheral hardware). The three NOP instructions provide the necessary timing delay for clock stabilization before the next instruction in the program sequence is executed.



## VENT — Load EMB, ERB, and Vector Address

VENTn dst

Operation:	Operand	Operation Summary	Bytes	Cycles
	EMB (0,1) ERB (0,1) ADR	Load enable memory bank flag (EMB) and the enable register bank flag (ERB) and program counter to vector address, then branch to the corresponding location.	2	2

**Description:** The VENT instruction loads the contents of the enable memory bank flag (EMB) and enable register bank flag (ERB) into the respective vector addresses. It then points the interrupt service routine to the corresponding branching locations. The program counter is loaded automatically with the respective vector addresses which indicate the starting address of the respective vector interrupt service routines.

The EMB and ERB flags should be modified using VENT before the vector interrupts are acknowledged. Then, when an interrupt is generated, the EMB and ERB values of the previous routine are automatically pushed onto the stack and then popped back when the routine is completed.

After the return from interrupt (IRET) you do not need to set the EMB and ERB values again. Instead, use BTR and BITS to clear these values in your program routine.

The starting addresses for vector interrupts and reset operations are pointed to by the VENTn instruction. These addresses must be stored in ROM locations 0000H–0FFFH. Generally, the VENTn instructions are coded starting at location 0000H.

The format for VENT instructions is as follows:

VENTn d1,d2,ADDR

EMB ← d1 ("0" or "1")

ERB ← d2 ("0" or "1")

PC ← ADDR (address to branch)

n = device-specific module address code (n = 0–n)

Operand	Binary Code								Operation Notation
EMB (0,1) ERB (0,1) ADR	E	E	0	0	a11	a10	a9	a8	ROM (2 x n) 7–6 ← EMB, ERB ROM (2 x n) 5–4 ← 0, PC12 ROM (2 x n) 3–0 ← PC11–8 ROM (2 x n + 1) 7–0 ← PC7–0 (n = 0, 1, 2, 3, 4, 5, 6, 7)
	M	R							
	B	B							
	a7	a6	a5	a4	a3	a2	a1	a0	

## VENT — Load EMB, ERB, and Vector Address

VENTn (Continued)

**Example:** The instruction sequence

```
ORG    0000H
VENT0  1,0,RESET
VENT1  0,1,INTB
VENT2  0,1,INT0
VENT3  0,1,INT1
ORG    000AH
VENT5  0,1,INTT0
```

causes the program sequence to branch to the RESET routine labeled 'RESET,' setting EMB to "1" and ERB to "0" when RESET is activated. When a basic timer interrupt is generated, VENT1 causes the program to branch to the basic timer's interrupt service routine, INTB, and to set the EMB value to "0" and the ERB value to "1". VENT2 then branches to INT0, VENT3 to INT1, and so on, setting the appropriate EMB and ERB values.

www.DataSheet4U.com



## XCH — Exchange A or EA with Nibble or Byte

**XCH** dst,src

Operation:	Operand	Operation Summary	Bytes	Cycles
	A,DA	Exchange A and data memory contents	2	2
	A,Ra	Exchange A and register (Ra) contents	1	1
	A,@RRa	Exchange A and indirect data memory	1	1
	EA,DA	Exchange EA and direct data memory contents	2	2
	EA,RRb	Exchange EA and register pair (RRb) contents	2	2
	EA,@HL	Exchange EA and indirect data memory contents	2	2

**Description:** The instruction XCH loads the accumulator with the contents of the indicated destination variable and writes the original contents of the accumulator to the source.

Operand	Binary Code								Operation Notation
A,DA	0	1	1	1	1	0	0	1	A ↔ DA
	a7	a6	a5	a4	a3	a2	a1	a0	
A,Ra	0	1	1	0	1	r2	r1	r0	A ↔ Ra
A,@RRa	0	1	1	1	1	i2	i1	i0	A ↔ (RRa)
EA,DA	1	1	0	0	1	1	1	1	A ↔ DA, E ↔ DA + 1
	a7	a6	a5	a4	a3	a2	a1	a0	
EA,RRb	1	1	0	1	1	1	0	0	EA ↔ RRb
	1	1	1	0	0	r2	r1	0	
EA,@HL	1	1	0	1	1	1	0	0	A ↔ (HL), E ↔ (HL + 1)
	0	0	0	0	0	0	0	1	

**Example:** Double register HL contains the address 20H. The accumulator contains the value 3FH (00111111B) and internal RAM location 20H the value 75H (01110101B). The instruction

```
XCH EA,@HL
```

leaves RAM location 20H with the value 3FH (00111111B) and the extended accumulator with the value 75H (01110101B).

## XCHD — Exchange and Decrement

**XCHD** dst,src

Operation:	Operand	Operation Summary	Bytes	Cycles
	A,@HL	Exchange A and data memory contents; decrement contents of register L and skip on borrow	1	2 + S

**Description:** The instruction XCHD exchanges the contents of the accumulator with the RAM location addressed by register pair HL and then decrements the contents of register L. If the content of register L is 0FH, the next instruction is skipped. The value of the carry flag is not affected.

Operand	Binary Code								Operation Notation
A,@HL	0	1	1	1	1	0	1	1	$A \leftrightarrow (HL)$ , then $L \leftarrow L-1$ ; skip if $L = 0FH$

**Example:** Register pair HL contains the address 20H and internal RAM location 20H contains the value 0FH:

```

LD    HL,#20H
LD    A,#0H
XCHD A,@HL ; A ← 0FH and L ← L - 1, (HL) ← "0"
JPS   XXX  ; Skipped since a borrow occurred
JPS   YYY  ; H ← 2H, L ← 0FH

YYY   XCHD A,@HL ; (2FH) ← 0FH, A ← (2FH), L ← L - 1 = 0EH
      .
      .
      .

```

The 'JPS YYY' instruction is executed since a skip occurs after the XCHD instruction.

## XCHI — Exchange and Increment

**XCHI** dst,src

Operation:	Operand	Operation Summary	Bytes	Cycles
	A,@HL	Exchange A and data memory contents; increment contents of register L and skip on overflow	1	2 + S

**Description:** The instruction XCHI exchanges the contents of the accumulator with the RAM location addressed by register pair HL and then increments the contents of register L. If the content of register L is 0H, a skip is executed. The value of the carry flag is not affected.

Operand	Binary Code								Operation Notation
A,@HL	0	1	1	1	1	0	1	0	A ↔ (HL), then L ← L+1; skip if L = 0H

**Example:** Register pair HL contains the address 2FH and internal RAM location 2FH contains 0FH:

```

LD    HL,#2FH
LD    A,#0H
XCHI  A,@HL      ; A ← 0FH and L ← L + 1 = 0, (HL) ← "0"
JPS   XXX        ; Skipped since an overflow occurred
JPS   YYY        ; H ← 2H, L ← 0H

YYY   XCHI  A,@HL      ; (20H) ← 0FH, A ← (20H), L ← L + 1 = 1H
      .
      .
      .

```

The 'JPS YYY' instruction is executed since a skip occurs after the XCHI instruction.

# XOR — Logical Exclusive OR

**XOR**          dst,src

Operation:	Operand	Operation Summary	Bytes	Cycles
	A,#im	Exclusive-OR immediate data to A	2	2
	A,@HL	Exclusive-OR indirect data memory to A	1	1
	EA,RR	Exclusive-OR register pair (RR) to EA	2	2
	RRb,EA	Exclusive-OR register pair (RRb) to EA	2	2

**Description:** XOR performs a bit wise logical XOR operation between the source and destination variables and stores the result in the destination. The source contents are unaffected.

Operand	Binary Code								Operation Notation
A,#im	1	1	0	1	1	1	0	1	A ← A XOR im
	0	0	1	1	d3	d2	d1	d0	
A,@HL	0	0	1	1	1	0	1	1	A ← A XOR (HL)
EA,RR	1	1	0	1	1	1	0	0	EA ← EA XOR (RR)
	0	0	1	1	0	r2	r1	0	
RRb,EA	1	1	0	1	1	1	0	0	RRb ← RRb XOR EA
	0	0	1	1	0	r2	r1	0	

**Example:** If the extended accumulator contains 0C3H (11000011B) and register pair HL contains 55H (01010101B), the instruction

```
XOR EA,HL
```

leaves the value 96H (10010110B) in the extended accumulator.

## NOTES

www.DataSheet4U.com



www.DataSheet4U.com

**Oscillator Circuits**

**Interrupts**

**Power-Down**

**RESET**

**I/O Ports**

**Timers and Timer/Counters**

**LCD Controller/Driver**

**Electrical Data**

**Mechanical Data**

**KS57P2304 OTP**

**Development Tools**

www.DataSheet4U.com

# 6

## OSCILLATOR CIRCUITS

### OVERVIEW

The KS57C2302/C2304 microcontroller has two oscillator circuits: a main system clock circuit, and a subsystem clock circuit. The CPU and peripheral hardware operate on the system clock frequency supplied through these circuits. Specifically, a clock pulse is required by the following peripheral modules:

- LCD controller
- Basic timer
- Timer/counter 0
- Watch timer
- Clock output circuit

### CPU Clock Notation

In this document, the following notation is used for descriptions of the CPU clock:

- fx Main system clock
- fxt Subsystem clock
- fxx Selected system clock



### Clock Control Registers

When the system clock mode control register, SCMOD, and the power control register, PCON, are both cleared to zero after RESET, the normal CPU operating mode is enabled, a main system clock of  $fx/64$  is selected, and main system clock oscillation is initiated.

PCON is used to select normal CPU operating mode or one of two power-down modes — stop or idle. Bits 3 and 2 of the PCON register can be manipulated by a STOP or IDLE instruction to engage stop or idle power-down mode.

The system clock mode control register, SCMOD, lets you select the *main system clock (fx)* or a *subsystem clock (fxt)* as the CPU clock and to start (or stop) main or sub system clock oscillation. The resulting clock source, either main system clock or subsystem clock, is referred to as the *CPU clock*.

The main system clock is selected and oscillation started when all SCMOD bits are cleared to logic zero. By setting SCMOD.3–2 and SCMOD.0 to different values, CPU can operate in a subsystem clock source and start or stop main or sub system clock oscillation. To stop main system clock oscillation, you must use the STOP instruction (assuming the main system clock is selected) or manipulate SCMOD.3 to “1” (assuming the sub system clock is selected).

The main system clock frequencies can be divided by 4, 8, or 64 and a subsystem clock frequencies can only be divided by 4. By manipulating PCON bits 1 and 0, you select one of the following frequencies as CPU clock.

$fx/4$ ,  $fxt/4$ ,  $fx/8$ ,  $fx/64$

### Using a Subsystem Clock

If a subsystem clock is being used as the selected system clock, the idle power-down mode can be initiated by executing an IDLE instruction. The subsystem clock can be stopped by setting SCMOD.2 to “1”.

The watch timer, buzzer and LCD display operate normally with a subsystem clock source, since they operate at very slow speeds (122  $\mu$ s at 32.768 kHz) and with very low power consumption.

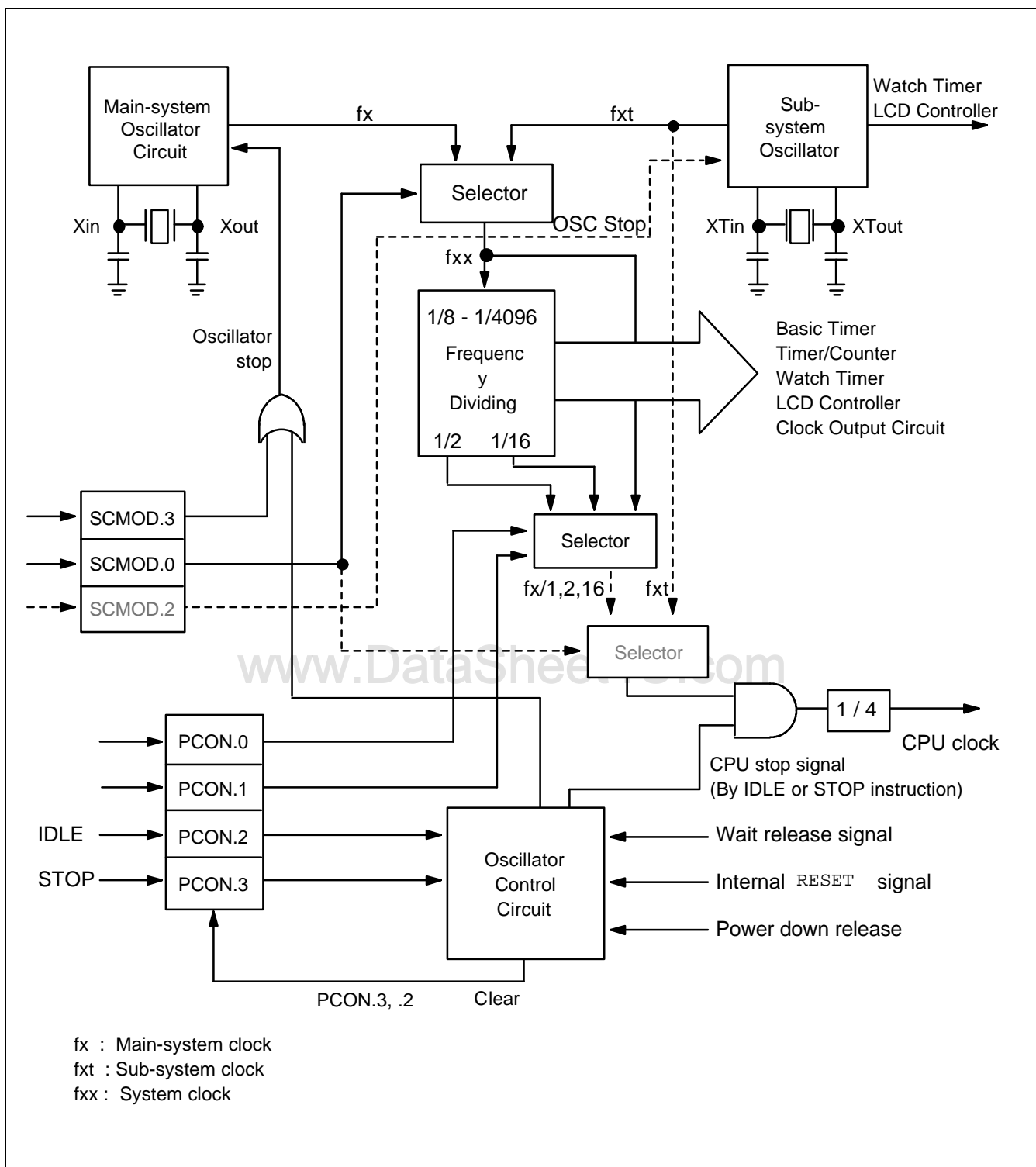

Figure 6-1. Clock Circuit Diagram



## MAIN SYSTEM OSCILLATOR CIRCUITS

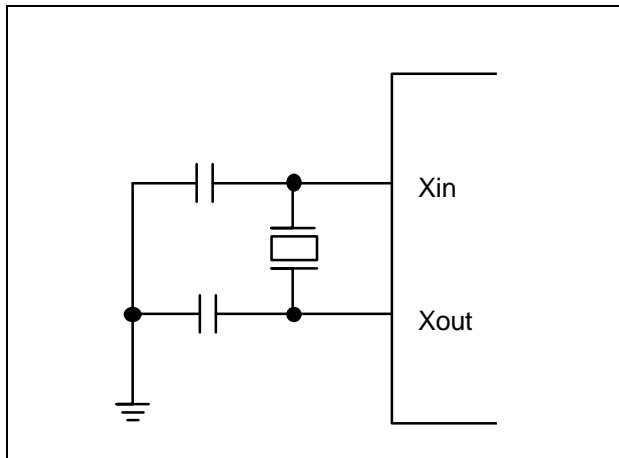

Figure 6-2. Crystal/Ceramic Oscillator

## SUBSYSTEM OSCILLATOR CIRCUITS

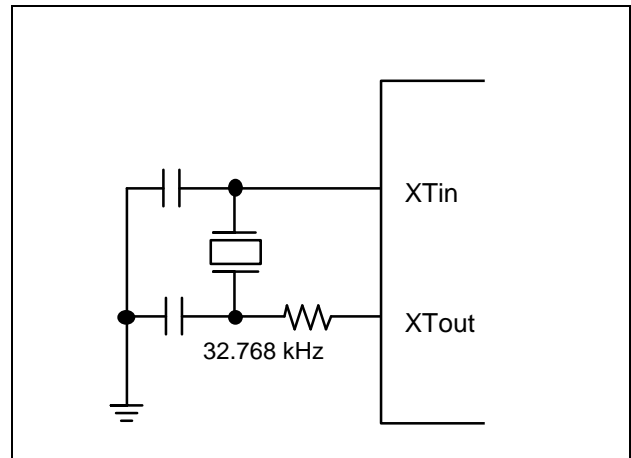

Figure 6-5. Crystal/Ceramic Oscillator

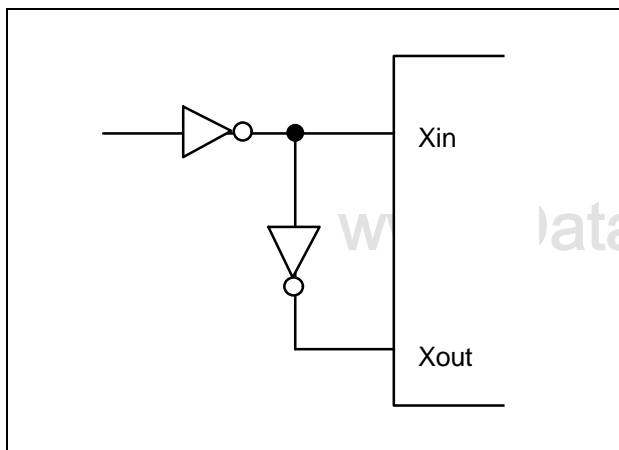

Figure 6-3. External Oscillator

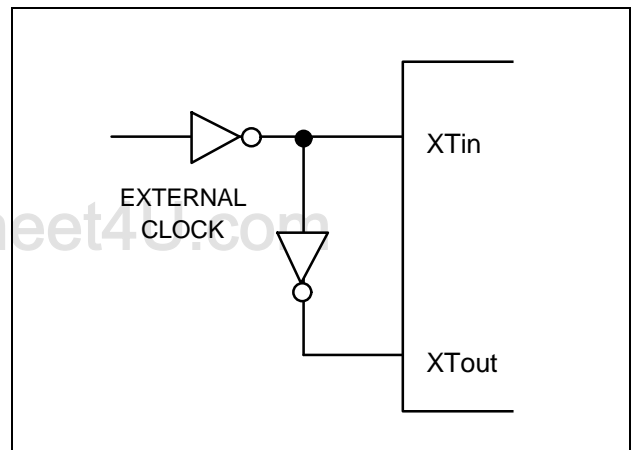

Figure 6-6. External Oscillator

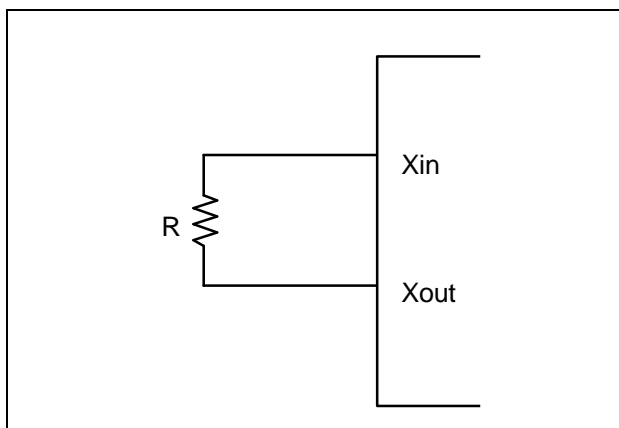
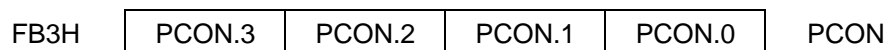

Figure 6-4. RC Oscillator

## POWER CONTROL REGISTER (PCON)

The power control register (PCON) is a 4-bit register that is used to select the CPU clock frequency and to control CPU operating and power-down modes. The PCON can be addressed directly by 4-bit write instructions or indirectly by the instructions IDLE and STOP.



PCON.3 and PCON.2 can be addressed only by the STOP and IDLE instructions, respectively, to engage the idle and stop power-down modes. Idle and stop modes can be initiated by these instruction despite the current value of the enable memory bank flag (EMB). PCON bits 1 and 0 can be written only by 4-bit RAM control instruction. PCON is a write-only register. There are three basic choices:

- Main system clock (fx) or subsystem clock (fxt);
- Divided fx clock frequency of 4, 8, or 64
- Divided fxt clock frequency of 4.

PCON.1 and PCON.0 settings are also connected with the system clock mode control register, SCMOD. If SCMOD.0 = "0", the main system clock is always selected by the PCON.1 and PCON.0 setting; if SCMOD.0 = "1" the subsystem clock is selected.

RESET sets PCON register values (and SCMOD) to logic zero.

**Table 6-1. Power Control Register (PCON) Organization**

PCON Bit Settings		Resulting CPU Clock Frequency	
PCON.1	PCON.0	SCMOD.0 = 0	SCMOD.0 = 1
0	0	fx/64	fxt/4
1	0	fx/8	
1	1	fx/4	

PCON Bit Settings		Resulting CPU Operating Mode
PCON.3	PCON.2	
0	0	Normal CPU operating mode
0	1	IDLE
1	0	STOP mode

 **PROGRAMMING TIP — Setting the CPU Clock**

To set the CPU clock to 0.95  $\mu$ s at 4.19 MHz:

```

BITS      EMB
SMB       15
LD        A,#3H
LD        PCON,A
  
```

### INSTRUCTION CYCLE TIMES

The unit of time that equals one machine cycle varies depending on whether the main system clock (fx) or a subsystem clock (fxt) is used, and on how the oscillator clock signal is divided (by 4, 8, or 64). Table 6-2 shows corresponding cycle times in microseconds.

**Table 6-2. Instruction Cycle Times for CPU Clock Rates**

Oscillation Source	Selected CPU Clock	Resulting Frequency	Cycle Time ( $\mu$ sec)
fx = 4.19 MHz	fx/64	65.5 kHz	15.3
	fx/8	524.0 kHz	1.91
	fx/4	1.05 MHz	0.95
fxt = 32.768 kHz	fxt/4	8.19 kHz	122.0

### SYSTEM CLOCK MODE REGISTER (SCMOD)

The system clock mode register, SCMOD, is a 4-bit register that is used to select the CPU clock and to control main and sub-system clock oscillation. SCMOD is mapped to the RAM address FB7H.

When main system clock is used as clock source, main system clock oscillation can be stopped by STOP instruction or setting SCMOD.3 (not recommended).

When the clock source is subsystem clock, main system clock oscillation is stopped by setting SCMOD.3. SCMOD.0, SCMOD.2 and SCMOD.3 cannot be simultaneously modified. Sub-oscillation goes into stop mode only by SCMOD.2. PCON which revokes stop mode cannot stop the sub-oscillation. The stop of sub-oscillation is released only by reset.

RESET clears all SCMOD values to logic zero, selecting the main system clock (fx) as the CPU clock and starting clock oscillation. The reset value of the SCMOD is 0.

SCMOD.3, SCMOD.2, SCMOD.0 bits can be manipulated by 1-bit write instructions (In other words, SCMOD.0, SCMOD.2 and SCMOD.3 cannot be modified simultaneously by a 4-bit write). Bit 1 is always logic zero.

FB7H	SCMOD.3	SCMOD.2	"0"	SCMOD.0	SCMOD
------	---------	---------	-----	---------	-------

A subsystem clock (fxt) can be selected as the system clock by manipulating the SCMOD.3 and SCMOD.0 bit settings. If SCMOD.3 = "0" and SCMOD.0 = "1", the subsystem clock is selected and main system clock oscillation continues. If SCMOD.3 = "1" and SCMOD.0 = "1", fxt is selected, but main system clock oscillation stops.

If you have selected fx as the CPU clock, setting SCMOD.3 to "1" will stop main system clock oscillation. But this mode must not be used. To stop main system clock oscillation safely, main oscillation clock should be stopped only by a STOP instruction in main system clock mode.

**Table 6-3. System Clock Mode Register (SCMOD) Organization**

SCMOD Register Bit Settings			Resulting Clock Selection		
SCMOD.3	SCMOD.2	SCMOD.0	fx Oscillation	fxt Oscillation	CPU Clock (note)
0	0	0	On	On	fx
0	1	0	On	Off	fx
0	0	1	On	On	fxt
1	0	1	Off	On	fxt

**NOTE:** CPU clock is selected by PCON register settings.

Table 6-4. Main/Sub Oscillation Stop Mode

Mode	Condition	Method to issue Osc Stop	Osc Stop Release Source (2)
Main Oscillation STOP Mode	Main oscillator runs. Sub oscillator runs (stops). System clock is the main oscillation clock.	STOP instruction: Main oscillator stops. CPU is in idle mode. Sub oscillator still runs (stops).	Interrupt and reset: After releasing stop mode, main oscillation starts and oscillation stabilization time is elapsed. And then the CPU operates. Oscillation stabilization time is $1 / \{256 \times \text{BT clock (fx)}\}$ .
		Set SCMOD.3 to "1" (1) Main oscillator stops, halting the CPU operation. Sub oscillator still runs (stops).	Reset: Interrupt can't start the main oscillation. Therefore, the CPU operation can never be restarted.
	Main oscillator runs. Sub oscillator runs. System clock is the sub oscillation clock.	STOP instruction: (1) Main oscillator stops. CPU is in idle mode. Sub oscillator still runs.	BTOverflow and reset: After the overflow of basic timer [ $1 / \{256 \times \text{BT clock (fxt)}\}$ ], CPU operation and main oscillation automatically start.
		Set SCMOD.3 to "1" Main oscillator stops. CPU still operates. Sub oscillator still runs.	Set SCMOD.3 to "0" or reset
Sub oscillation STOP Mode	Main oscillator runs. Sub oscillator runs. System clock is the main oscillation clock.	Set SCMOD.2 to "1" Main oscillator still runs. CPU operates. Sub oscillator stops.	Set SCMOD.2 to "0" or reset
	Main oscillator runs (stops). Sub oscillator runs. System clock is the sub oscillation clock.	Set SCMOD.2 to "1" Main oscillator still runs (stops). Sub oscillator stops, halting the CPU operation.	Reset

**NOTES:** 1. This mode must not be used.

2. Oscillation stabilization time by interrupt is  $1 / (256 \times \text{BT clocks})$ . Oscillation stabilization time by a reset is 31.3ms at 4.19Mhz, main oscillation clock.

Table 6-5. System Operating Mode Comparison

Mode	Condition	STOP/IDLE Mode Start Method	Current Consumption
Main operating mode	Main oscillator runs. Sub oscillator runs (stops). System clock is the main oscillation clock.	–	A
Main Idle mode	Main oscillator runs. Sub oscillator runs (stops). System clock is the main oscillation clock.	IDLE instruction	B
Main Stop mode	Main oscillator runs. Sub oscillator runs. System clock is the main oscillation clock.	STOP instruction	D
Sub operating mode	Main oscillator is stopped by SCMOD.3. Sub oscillator runs. System clock is the sub oscillation clock.	–	C
Sub Idle Mode	Main oscillator is stopped by SCMOD.3. Sub oscillator runs. System clock is the sub oscillation clock.	IDLE instruction	D
Sub Stop mode	Main oscillator is stopped by SCMOD.3. Sub oscillator runs. System clock is the sub oscillation clock.	Setting SCMOD.2 to "1": This mode can be released only by an external reset.	E
Main/Sub Stop mode	Main oscillator runs. Sub oscillator is stopped by SCMOD.2. System clock is the main oscillation clock.	STOP instruction: This mode can be released by an interrupt and reset.	E

**NOTE:** The current consumption is: A > B > C > D > E.



## SWITCHING THE CPU CLOCK

Together, bit settings in the power control register, PCON, and the system clock mode register, SCMOD, determine whether a main system or a subsystem clock is selected as the CPU clock, and also how this frequency is to be divided. This makes it possible to switch dynamically between main and subsystem clocks and to modify operating frequencies.

SCMOD.3, scmod.2, and SCMOD.0 select the main system clock (fx) or a subsystem clock (fxt) and start or stop main or sub system clock oscillation. PCON.1 and PCON.0 control the frequency divider circuit, and divide the selected fx clock by 4, 8, 64, or fxt clock by 4.

### NOTE

A clock switch operation does not go into effect immediately when you make the SCMOD and PCON register modifications — the previously selected clock continues to run for a certain number of machine cycles.

For example, you are using the default CPU clock (normal operating mode and a main system clock of fx/64) and you want to switch from the fx clock to a subsystem clock and to stop the main system clock. To do this, you first need to set SCMOD.0 to "1". This switches the clock from fx to fxt but allows main system clock oscillation to continue. Before the switch actually goes into effect, a certain number of machine cycles must elapse. After this time interval, you can then disable main system clock oscillation by setting SCMOD.3 to "1".

This same 'stepped' approach must be taken to switch from a subsystem clock to the main system clock: First, clear SCMOD.3 to "0" to enable main system clock oscillation. Until main osc is stabilized, system clock must not be changed. Then, after a certain number of machine cycles has elapsed, select the main system clock by clearing all SCMOD values to logic zero.

Following a RESET, CPU operation starts with the lowest main system clock frequency of 15.3  $\mu$ sec at 4.19 MHz after the standard oscillation stabilization interval of 31.3 ms has elapsed. Table 6-6 details the number of machine cycles that must elapse before a CPU clock switch modification goes into effect.

Table 6-6. Elapsed Machine Cycles During CPU Clock Switch

BEFORE	AFTER	SCMOD.0 = 0				SCMOD.0 = 1
		PCON.1 = 0	PCON.0 = 0	PCON.1 = 1	PCON.0 = 0	
SCMOD.0 = 0	PCON.1 = 0	N/A		1 MACHINE CYCLE		N/A
	PCON.0 = 0					
	PCON.1 = 1	8 MACHINE CYCLES		N/A		N/A
	PCON.0 = 0					
	PCON.1 = 1	16 MACHINE CYCLES		16 MACHINE CYCLES		fx / 4fxt
	PCON.0 = 1					MACHINE CYCLE
SCMOD.0 = 1		N/A		N/A		fx / 4fxt (M/C)

**NOTES:**

1. Even if oscillation is stopped by setting SCMOD.3 during main system clock operation, the stop mode is not entered.
2. Since the X<sub>IN</sub> input is connected internally to V<sub>SS</sub> to avoid current leakage due to the crystal oscillator in stop mode, do not set SCMOD.3 to "1" or STOP instruction when an external clock is used as the main system clock.
3. When the system clock is switched to the subsystem clock, it is necessary to disable any interrupts which may occur during the time intervals shown in Table 6-6.
4. 'N/A' means 'not available'.
5. fx: Main-system clock, fxt: Sub-system clock, M/C: Machine Cycle.  
When fx is 4.19 MHz, and fxt is 32.768 kHz.

**PROGRAMMING TIP — Switching Between Main System and Subsystem Clock**

1. Switch from the main system clock to the subsystem clock:

```

MA2SUB  BITS    SCMOD.0      ; Switches to subsystem clock
        CALL    DLY80        ; Delay 80 machine cycles
        BITS    SCMOD.3      ; Stop the main system clock
        RET
DLY80   LD      A,#0FH
DEL1    NOP
        NOP
        DECS   A
        JR     DEL1
        RET

```

2. Switch from the subsystem clock to the main system clock:

```

SUB2MA  BITR    SCMOD.3      ; Start main system clock oscillation
        CALL    DLY80        ; Delay 80 machine cycles
        CALL    DLY80        ; Delay 80 machine cycles
        BITR    SCMOD.0      ; Switch to main system clock
        RET

```

**CLOCK OUTPUT MODE REGISTER (CLMOD)**

The clock output mode register, CLMOD, is a 4-bit register that is used to enable or disable clock output to the CLO pin and to select the CPU clock source and frequency. CLMOD is addressable by 4-bit write instructions only.

FD0H    

CLMOD.3	"0"	CLMOD.1	CLMOD.0
---------	-----	---------	---------

    CLMOD

RESET clears CLMOD to logic zero, which automatically selects the CPU clock as the clock source (without initiating clock oscillation), and disables clock output.

CLMOD.3 is the enable/disable clock output control bit; CLMOD.1 and CLMOD.0 are used to select one of four possible clock sources and frequencies: normal CPU clock,  $f_{xx}/8$ ,  $f_{xx}/16$ , or  $f_{xx}/64$ .

**Table 6-7. Clock Output Mode Register (CLMOD) Organization**

CLMOD Bit Settings		Resulting Clock Output	
CLMOD.1	CLMOD.0	Clock Source	Frequency
0	0	CPU clock ( $f_x/4$ , $f_x/8$ , $f_x/64$ , $f_{xt}/4$ )	1.05 MHz, 524 kHz, 65.5 kHz
0	1	$f_{xx}/8$	524 kHz
1	0	$f_{xx}/16$	262 kHz
1	1	$f_{xx}/64$	65.5 kHz

CLMOD.3	Result of CLMOD.3 Setting
0	Clock output is disabled
1	Clock output is enabled

**NOTE:** Assumes that  $f_{xx} = 4.19$  MHz.

## CLOCK OUTPUT CIRCUIT

The clock output circuit, used to output clock pulses to the CLO pin, has the following components:

- 4-bit clock output mode register (CLMOD)
- Clock selector
- Port mode flag
- CLO output pin (P2.2)

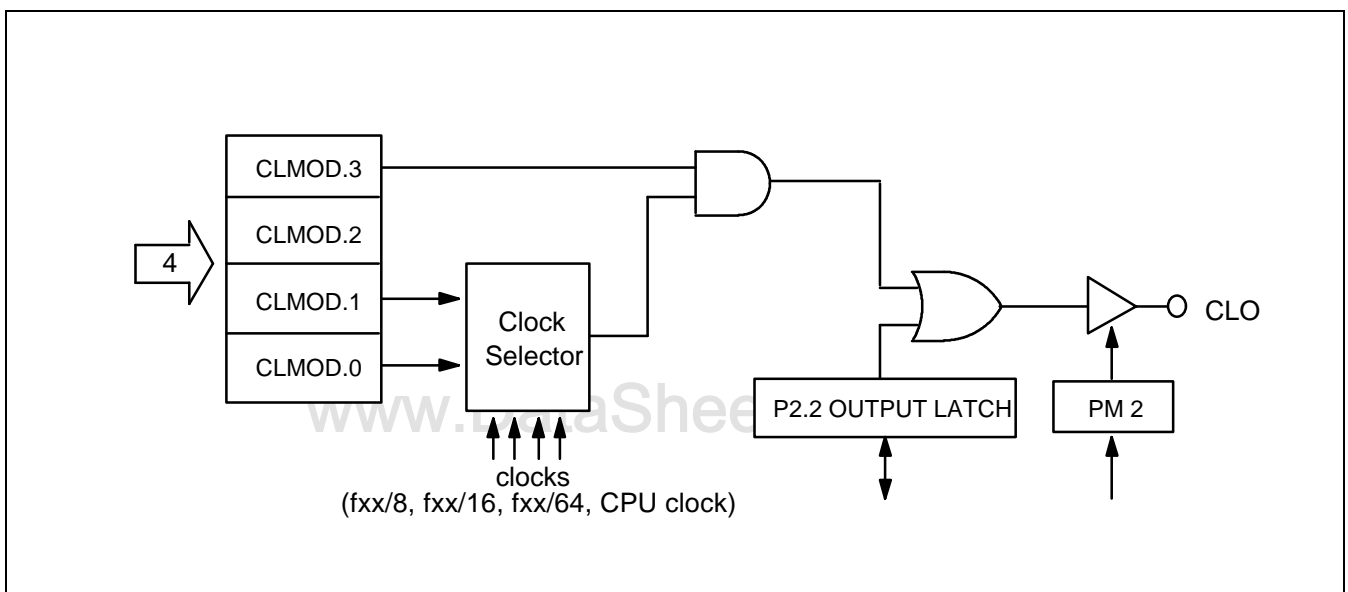

Figure 6-7. CLO Output Pin Circuit Diagram

## CLOCK OUTPUT PROCEDURE

The procedure for outputting clock pulses to the CLO pin may be summarized as follows:

1. Disable clock output by clearing CLMOD.3 to logic zero.
2. Set the clock output frequency (CLMOD.1, CLMOD.0).
3. Load "0" to the output latch of the CLO pin (P2.2).
4. Set the P2.2 mode flag (PM2) to output mode.
5. Enable clock output by setting CLMOD.3 to logic one.

**PROGRAMMING TIP — CPU Clock Output to the CLO Pin**

To output the CPU clock to the CLO pin:

BITS	EMB	
SMB	15	
LD	EA,#04H	
LD	PMG2,EA	; P2 ← Output mode
BITR	P2.2	; Clear P2.2 pin output latch
LD	A,#9H	
LD	CLMOD,A	

www.DataSheet4U.com

# 7 INTERRUPTS

## OVERVIEW

The KS57C2302/C2304 interrupt control circuit has five functional components:

- Interrupt enable flags (IEx)
- Interrupt request flags (IRQx)
- Interrupt master enable register (IME)
- Interrupt priority register (IPR)
- Power-down release signal circuit

Three kinds of interrupts are supported:

- Internal interrupts generated by on-chip processes
- External interrupts generated by external peripheral devices
- Quasi-interrupts used for edge detection and as clock sources

**Table 7-1. Interrupt Types and Corresponding Port Pin(s)**

Interrupt Type	Interrupt Name	Corresponding Port Pins
External interrupts	INT0, INT1	P1.0, P1.1
Internal interrupts	INTB, INTT0	Not applicable
Quasi-interrupts	INT2, KS0–KS3	P1.2, P6.0–P6.3
	INTW	Not applicable

### Vectored Interrupts

Interrupt requests may be processed as vectored interrupts in hardware, or they can be generated by program software. A vectored interrupt is generated when the following flags and register settings, corresponding to the specific interrupt (INTn) are set to logic one:

- Interrupt enable flag (IEx)
- Interrupt master enable flag (IME)
- Interrupt request flag (IRQx)
- Interrupt status flags (IS0, IS1)
- Interrupt priority register (IPR)

If all conditions are satisfied for the execution of a requested service routine, the start address of the interrupt is loaded into the program counter and the program starts executing the service routine from this address.

EMB and ERB flags for RAM memory banks and registers are stored in the vector address area of the ROM during interrupt service routines. The flags are stored at the beginning of the program with the VENT instruction. The initial flag values determine the vectors for resets and interrupts. Enable flag values are saved during the main routine, as well as during service routines. Any changes that are made to enable flag values during a service routine are not stored in the vector address.

When an interrupt occurs, the enable flag values before the interrupt is initiated are saved along with the program status word (PSW), and the enable flag values for the interrupt is fetched from the respective vector address. Then, if necessary, you can modify the enable flags during the interrupt service routine. When the interrupt service routine is returned to the main routine by the IRET instruction, the original values saved in the stack are restored and the main program continues program execution with these values.

### Software-Generated Interrupts

To generate an interrupt request from software, the program manipulates the appropriate IRQx flag. When the interrupt request flag value is set, it is retained until all other conditions for the vectored interrupt have been met, and the service routine can be initiated.

### Multiple Interrupts

By manipulating the two interrupt status flags (IS0 and IS1), you can control service routine initialization and thereby process multiple interrupts simultaneously.

If more than four interrupts are being processed at one time, you can avoid possible loss of working register data by using the PUSH RR instruction to save register contents to the stack before the service routines are executed in the same register bank. When the routines have executed successfully, you can restore the register contents from the stack to working memory using the POP instruction.

### Power-Down Mode Release

An interrupt (with the exception of INT0) can be used to release power-down mode (stop or idle). Interrupts for power-down mode release are initiated by setting the corresponding interrupt enable flag. Even if the IME flag is cleared to zero, power-down mode will be released by an interrupt request signal when the interrupt enable flag has been set. In such cases, the interrupt routine will not be executed since IME = "0".

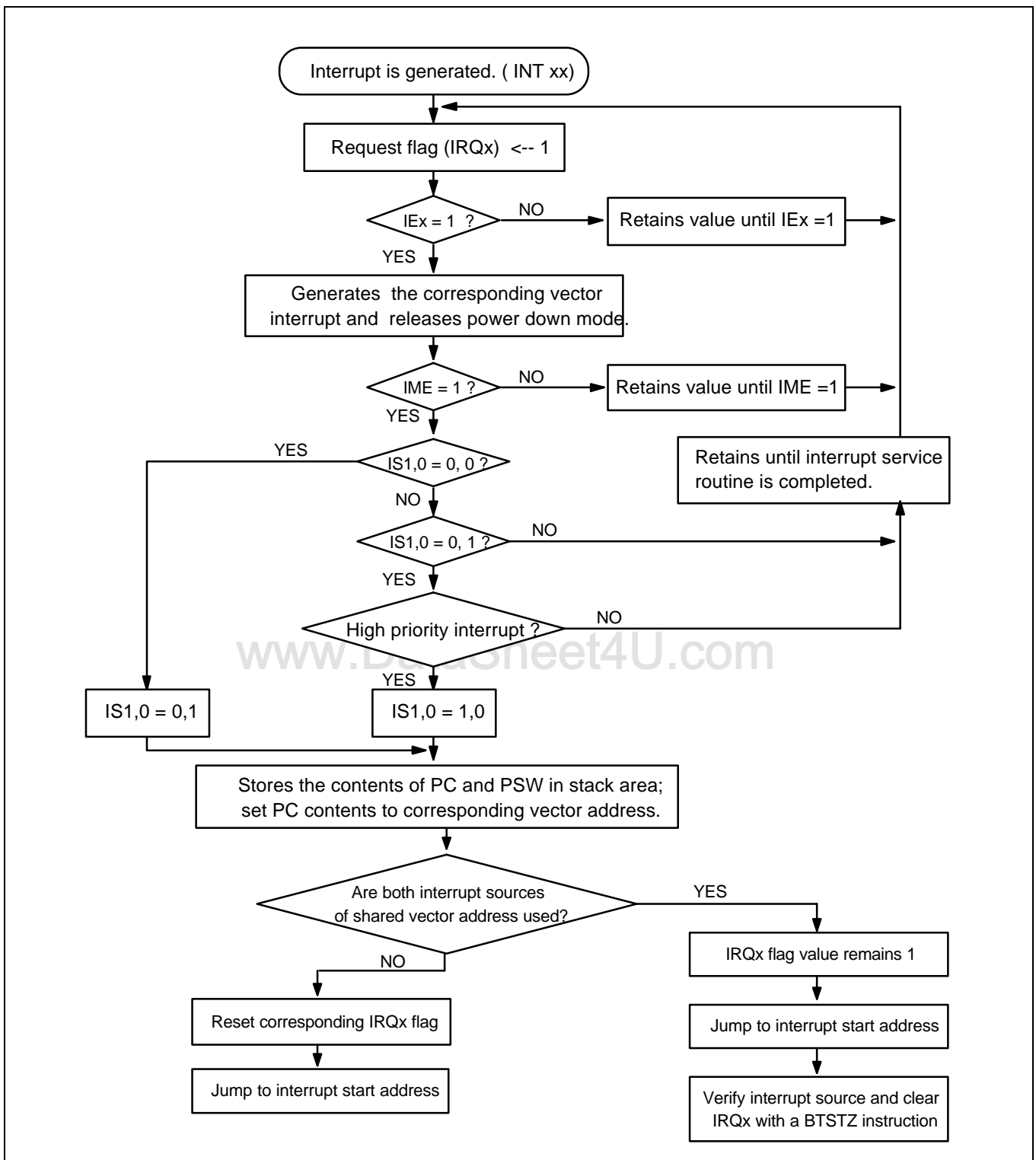

Figure 7-1. Interrupt Execution Flowchart



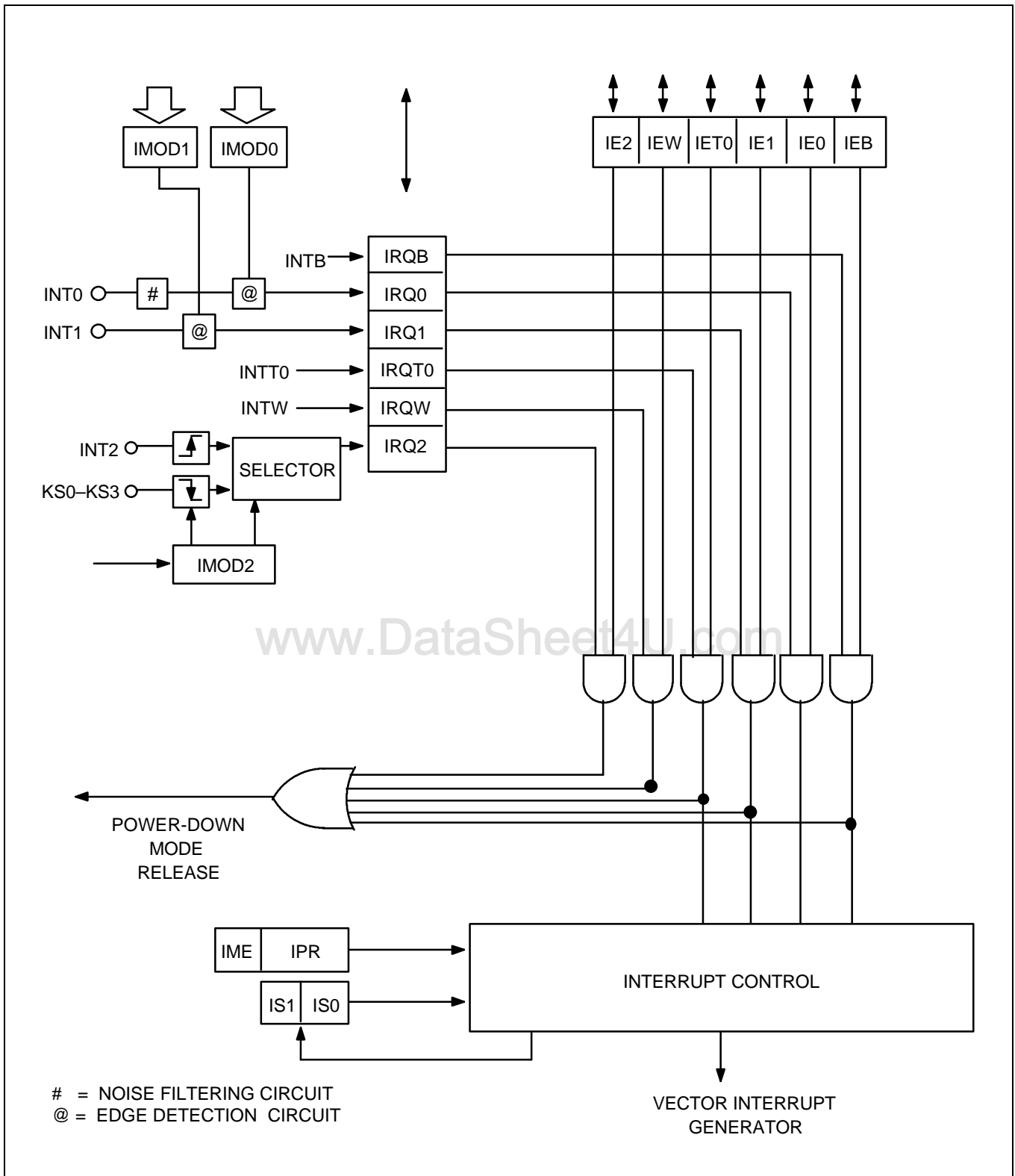

Figure 7-2. Interrupt Control Circuit Diagram

## MULTIPLE INTERRUPTS

The interrupt controller can service multiple interrupts in two ways: as two-level interrupts, where either all interrupt requests or only those of highest priority are serviced, or as multi-level interrupts, when the interrupt service routine for a lower-priority request is accepted during the execution of a higher priority routine.

### Two-Level Interrupt Handling

Two-level interrupt handling is the standard method for processing multiple interrupts. When the IS1 and IS0 bits of the PSW (FB0H.3 and FB0H.2, respectively) are both logic zero, program execution mode is normal and all interrupt requests are serviced (see Figure 7-3).

Whenever an interrupt request is accepted, IS1 and IS0 are incremented by one, and the values are stored in the stack along with the other PSW bits. After the interrupt routine has been serviced, the modified IS1 and IS0 values are automatically restored from the stack by an IRET instruction.

IS0 and IS1 can be manipulated directly by 1-bit write instructions, regardless of the current value of the enable memory bank flag (EMB). Before you modify an interrupt service flag, however, you must first disable interrupt processing with a DI instruction.

When IS1 = "0" and IS0 = "1", all interrupt service routines are inhibited except for the highest priority interrupt currently defined by the interrupt priority register (IPR).

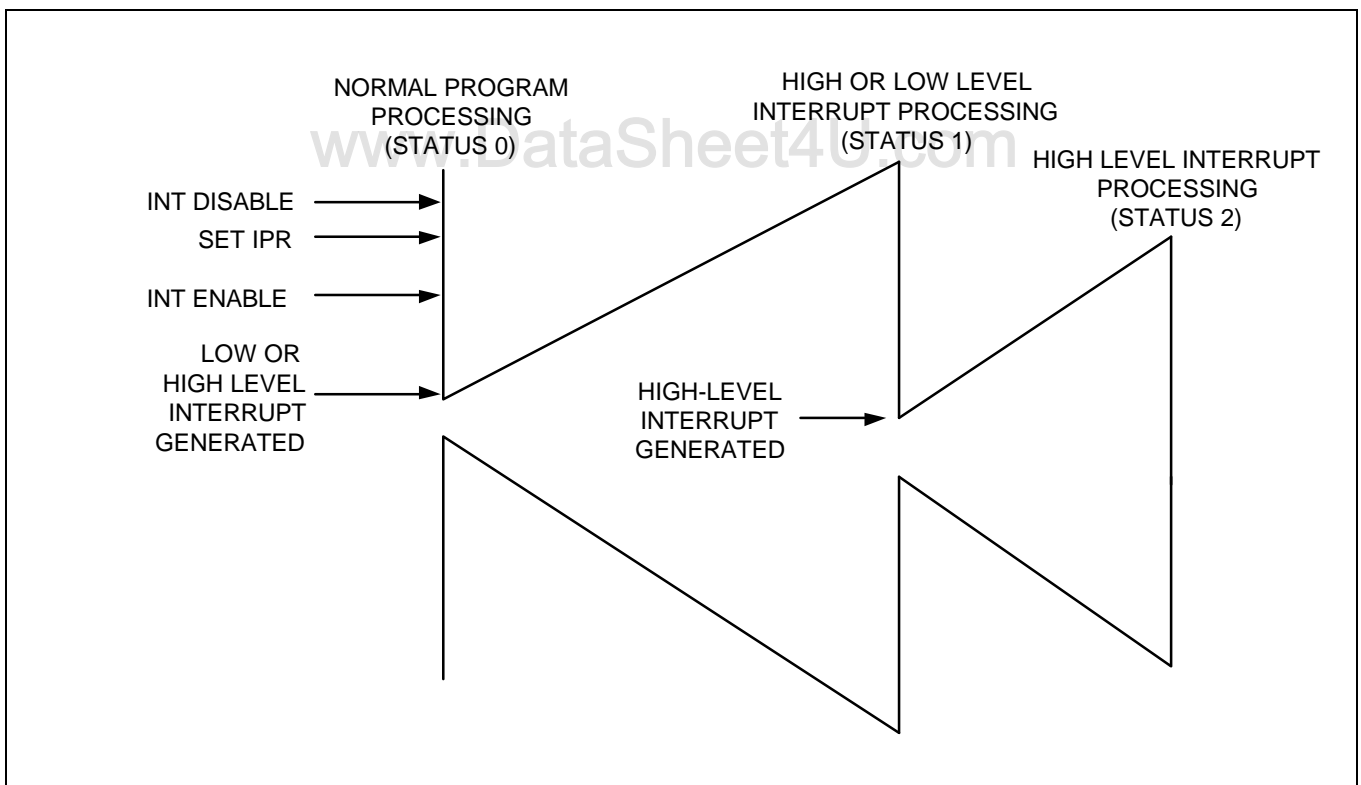

Figure 7-3. Two-Level Interrupt Handling

### Multi-Level Interrupt Handling

With multi-level interrupt handling, a lower-priority interrupt request can be executed by manipulating the interrupt status flags, IS0 and IS1 while a high-priority interrupt is being serviced (see Table 7-2).

When an interrupt is requested during normal program execution, interrupt status flags IS0 and IS1 are set to "1" and "0", respectively. This setting allows only highest-priority interrupts to be serviced. When a high-priority request is accepted, both interrupt status flags are then cleared to "0" by software so that a request of any priority level can be serviced. In this way, the high- and low-priority requests can be serviced in parallel (see Figure 7-4).

**Table 7-2. IS1 and IS0 Bit Manipulation for Multi-Level Interrupt Handling**

Process Status	Before INT		Effect of ISx Bit Setting	After INT ACK	
	IS1	IS0		IS1	IS0
0	0	0	All interrupt requests are serviced.	0	1
1	0	1	Only high-priority interrupts as determined by the current settings in the IPR register are serviced.	1	0
2	1	0	No additional interrupt requests will be serviced.	–	–
–	1	1	Value undefined	–	–

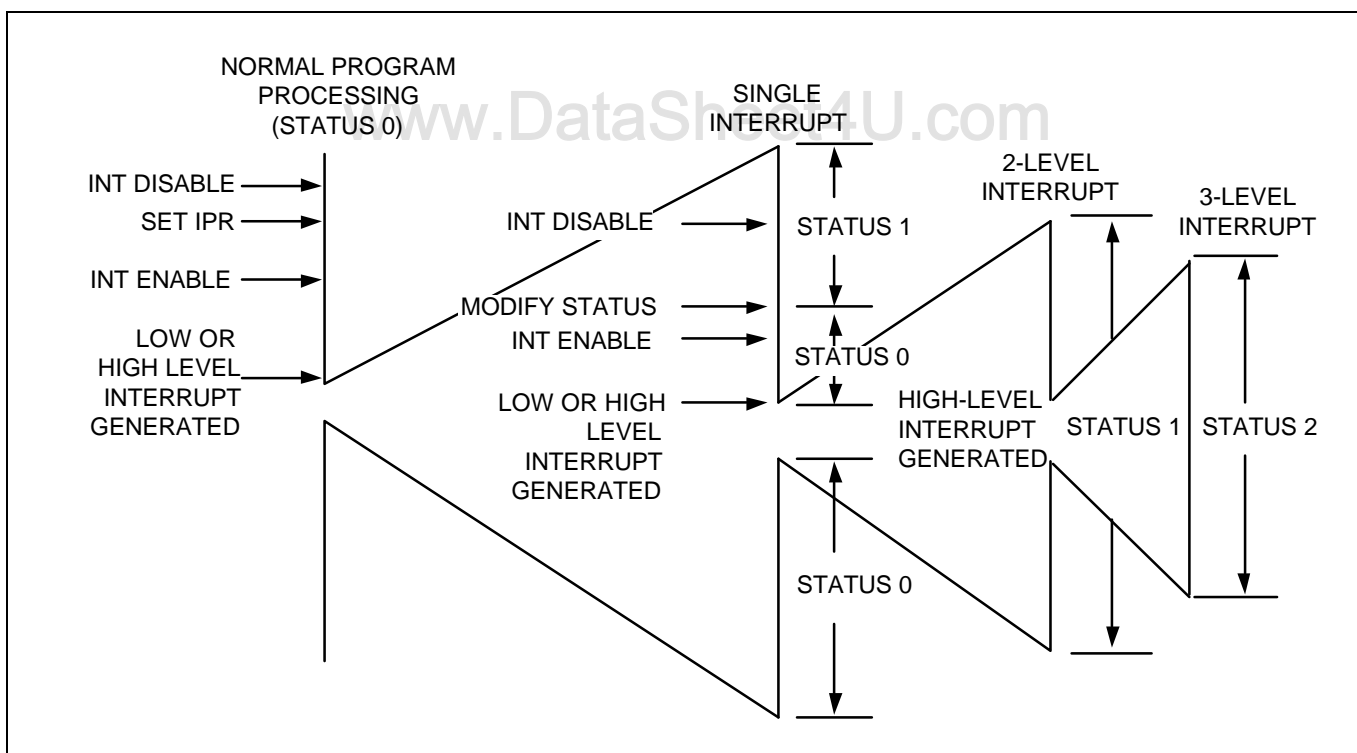

**Figure 7-4. Multi-Level Interrupt Handling**

### INTERRUPT PRIORITY REGISTER (IPR)

The 4-bit interrupt priority register (IPR) is used to control multi-level interrupt handling. Its reset value is logic zero. Before the IPR can be modified by 4-bit write instructions, all interrupts must first be disabled by a DI instruction.

FB2H	IME	IPR.2	IPR.1	IPR.0
------	-----	-------	-------	-------

By manipulating the IPR settings, you can choose to process all interrupt requests with the same priority level, or you can select one type of interrupt for high-priority processing. A low-priority interrupt can itself be interrupted by a high-priority interrupt, but not by another low-priority interrupt. A high-priority interrupt cannot be interrupted by any other interrupt source.

**Table 7-3. Standard Interrupt Priorities**

Interrupt	Default Priority
INTB	1
INT0	2
INT1	3
INTT0	4

The MSB of the IPR, the interrupt master enable flag (IME), enables and disables all interrupt processing. Even if an interrupt request flag and its corresponding enable flag are set, a service routine cannot be executed until the IME flag is set to logic one. The IME flag (mapped FB2H.3) can be directly manipulated by EI and DI instructions, regardless of the current enable memory bank (EMB) value.

**Table 7-4. Interrupt Priority Register Settings**

IPR.2	IPR.1	IPR.0	Result of IPR Bit Setting
0	0	0	Normal interrupt handling according to default priority settings
0	0	1	Process INTB interrupt at highest priority
0	1	0	Process INT0 interrupt at highest priority
0	1	1	Process INT1 interrupt at highest priority
1	0	0	Reserved
1	0	1	Process INTT0 interrupt at highest priority

**NOTE:** During normal interrupt processing, interrupts are processed in the order in which they occur. If two or more interrupt requests are received simultaneously, the priority level is determined according to the standard interrupt priorities in Table 7-3 (the default priority assigned by hardware when the lower three IPR bits = "0"). In this case, the higher-priority interrupt request is serviced and the other interrupt is inhibited. Then, when the high-priority interrupt is returned from its service routine by an IRET instruction, the inhibited service routine is started.

### PROGRAMMING TIP — Setting the INT Interrupt Priority

The following instruction sequence sets the INT1 interrupt to high priority:

```

BITS      EMB
SMB      15
DI                ; IPR.3 (IME) ← 0
LD      A,#3H
LD      IPR,A
EI                ; IPR.3 (IME) ← 1

```

### EXTERNAL INTERRUPT 0 AND 1 MODE REGISTERS (IMOD0 and IMOD1)

The following components are used to process external interrupts at the INT0 and INT1 pins:

- Noise filtering circuit for INT0
- Edge detection circuit
- Two mode registers, IMOD0 and IMOD1

The mode registers are used to control the triggering edge of the input signal. IMOD0 and IMOD1 settings let you choose either the rising or falling edge of the incoming signal as the interrupt request trigger. Since INT2 is a quasi-interrupt, the interrupt request flag (IRQ2) must be cleared by software.

FB4H	IMOD0.3	"0"	IMOD0.1	IMOD0.0
FB5H	"0"	"0"	"0"	IMOD1.0

IMOD0 and IMOD1 are addressable by 4-bit write instructions. RESET clears all IMOD values to logic zero, selecting rising edges as the trigger for incoming interrupt requests.

**Table 7-5. IMOD0, 1 and 2 Register Organization**

IMOD0	IMOD0.3	0	IMOD0.1	IMOD0.0	Effect of IMOD0 Settings	
	0					Select CPU clock for sampling
1					Select fxx/64 sampling clock	
			0	0	Rising edge detection	
			0	1	Falling edge detection	
			1	0	Both rising and falling edge detection	
			1	1	IRQ0 flag cannot be set to "1"	
IMOD1	0	0	0	IMOD1.0	Effect of IMOD1 Settings	
					0	Rising edge detection
					1	Falling edge detection

**EXTERNAL INTERRUPT 0 AND 1 MODE REGISTERS (Continued)**

When a sampling clock rate of  $fx/64$  is used for INT0, an interrupt request flag must be cleared before 16 machine cycles have elapsed. Since the INT0 pin has a clock-driven noise filtering circuit built into it, please take the following precautions when you use it:

- To trigger an interrupt, the input signal width at INT0 must be at least two times wider than the pulse width of the clock selected by IMOD0.

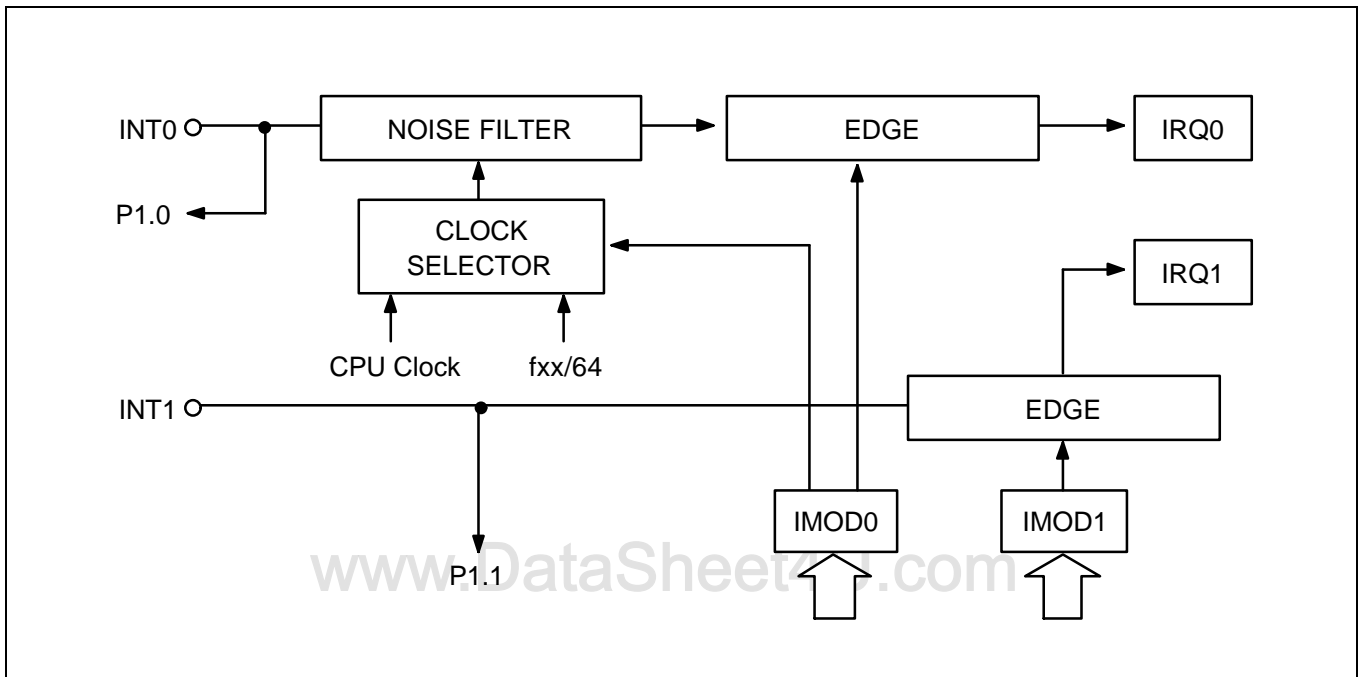

**Figure 7-5. Circuit Diagram for INT0 and INT1 Pins**

When modifying the IMOD registers, it is possible to accidentally set an interrupt request flag. To avoid unwanted interrupts, take these precautions when writing your programs:

1. Disable all interrupts with a DI instruction.
2. Modify the IMOD register.
3. Clear all relevant interrupt request flags.
4. Enable the interrupt by setting the appropriate IEx flag.
5. Enable all interrupts with an EI instructions.

**EXTERNAL INTERRUPT 2 MODE REGISTER (IMOD2)**

The mode register for external interrupt 2 at the KS0–KS3 pins, IMOD2, is addressable only by 4-bit write instructions. RESET clears all IMOD2 bits to logic zero.

FB6H	"0"	"0"	IMOD2.1	IMOD2.0
------	-----	-----	---------	---------

If a rising or falling edge is detected at any one of the selected KS pin by the IMOD2 register, the IRQ2 flag is set to logic one and a release signal for power-down mode is generated.

**Table 7-6. IMOD2 Register Bit Settings**

IMOD2	0	0	IMOD2.1	IMOD2.0	Effect of IMOD2 Settings
				0	0
			0	1	Reserved
			1	0	Select falling edge at KS2–KS3
			1	1	Select falling edge at KS0–KS3

www.DataSheet4U.com

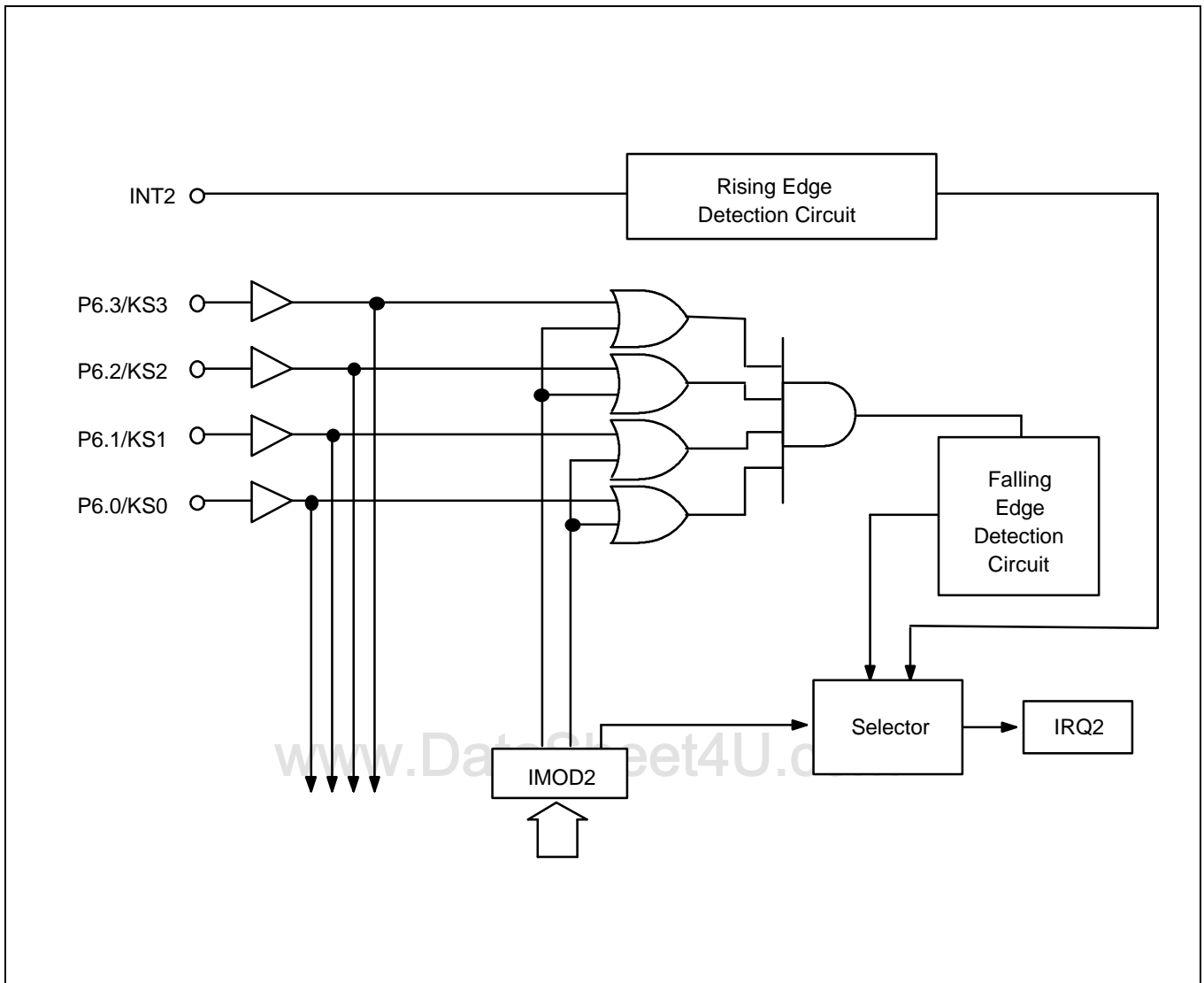

Figure 7-6. Circuit Diagram for INT2 and KS0-KS3 Pins



## INTERRUPT FLAGS

There are three types of interrupt flags: interrupt request and interrupt enable flags that correspond to each interrupt, the interrupt master enable flag, which enables or disables all interrupt processing.

### Interrupt Master Enable Flag (IME)

The interrupt master enable flag, IME, enables or disables all interrupt processing. Therefore, even when an IRQx flag is set and its corresponding IEx flag is enabled, the interrupt service routine is not executed until the IME flag is set to logic one.

The IME flag is located in the IPR register (IPR.3). It can be directly be manipulated by EI and DI instructions, regardless of the current value of the enable memory bank flag (EMB).

FB2H	IME	IPR.2	IPR.1	IPR.0	Effect of Bit Settings
	0				Inhibit all interrupts
	1				Allow all interrupts

### Interrupt Enable Flags (IEx)

IEx flags, when set to logical one, enable specific interrupt requests to be serviced. When the interrupt request flag is set to logical one, an interrupt will not be serviced until its corresponding IEx flag is also enabled.

Interrupt enable flags can be read, written, or tested directly by 1-bit instructions. IEx flags can be addressed directly at their specific RAM addresses, despite the current value of the enable memory bank (EMB) flag.

Table 7-7. Interrupt Enable and Interrupt Request Flag Addresses

Address	Bit 3	Bit 2	Bit 1	Bit 0
FB8H	0	0	IEB	IRQB
FBAH	0	0	IEW	IRQW
FBCH	0	0	IET0	IRQT0
FBEH	IE1	IRQ1	IE0	IRQ0
FBFH	0	0	IE2	IRQ2

#### NOTES:

1. IEx refers generally to all interrupt enable flags.
2. IRQx refers generally to all interrupt request flags.
3. IEx = 0 is interrupt disable mode.
4. IEx = 1 is interrupt enable mode.

### Interrupt Request Flags (IRQx)

Interrupt request flags are read/write addressable by 1-bit or 4-bit instructions. IRQx flags can be addressed directly at their specific RAM addresses, regardless of the current value of the enable memory bank (EMB) flag.

When a specific IRQx flag is set to logic one, the corresponding interrupt request is generated. The flag is then automatically cleared to logic zero when the interrupt has been serviced. Exceptions are the watch timer interrupt request flags, IRQW, and the external interrupt 2 flag IRQ2, which must be cleared by software after the interrupt service routine has executed. IRQx flags are also used to execute interrupt requests from software. In summary, follow these guidelines for using IRQx flags:

1. IRQx is set to request an interrupt when an interrupt meets the set condition for interrupt generation.
2. IRQx is set to "1" by hardware and then cleared by hardware when the interrupt has been serviced (with the exception of IRQW and IRQ2).
3. When IRQx is set to "1" by software, an interrupt is generated.

**Table 7-8. Interrupt Request Flag Conditions and Priorities**

Interrupt Source	Internal / External	Pre-condition for IRQx Flag Setting	Interrupt Priority	IRQ Flag Name
INTB	I	Reference time interval signal from basic timer	1	IRQB
INT0	E	Rising or falling edge detected at INT0 pin	2	IRQ0
INT1	E	Rising or falling edge detected at INT1 pin	3	IRQ1
INTT0	I	Signals for TCNT0 and TREF0 registers match	4	IRQT0
INT2 <sup>(note)</sup>	E	Rising edge detected at INT2	–	IRQ2
INTW	I	Time interval of 0.5 secs or 3.19 msec	–	IRQW

**NOTE:** The quasi-interrupt INT2 is only used for testing incoming signals.

**NOTES**

www.DataSheet4U.com

# 8 POWER-DOWN

## OVERVIEW

The KS57C2302/C2304 microcontroller has two power-down modes to reduce power consumption: idle and stop. Idle mode is initiated by the IDLE instruction and stop mode by the instruction STOP. (Several NOP instructions must always follow an IDLE or STOP instruction in a program.) In idle mode, the CPU clock stops while peripherals and the oscillation source continue to operate normally.

When RESET occurs during normal operation or during a power-down mode, a reset operation is initiated and the CPU enters idle mode. When the standard oscillation stabilization time interval (31.3 ms at 4.19 MHz) has elapsed, normal CPU operation resumes.

In main stop mode, main system clock oscillation is halted (assuming main clock is selected as system clock and it is currently operating), and peripheral hardware components are powered-down. In sub stop mode, (assuming sub clock is selected) sub system clock oscillation is halted by setting SCMOD.2 to "1". The effect of stop mode on specific peripheral hardware components — CPU, basic timer, timer/ counter 0, watch timer, and LCD controller — and on external interrupt requests, is detailed in Table 8-1.

### NOTE

Do not use stop mode if you are using an external clock source because  $X_{in}$  input must be restricted internally to  $V_{SS}$  to reduce current leakage.

Idle or main stop modes are terminated either by a RESET, or by an interrupt which is enabled by the corresponding interrupt enable flag, IEx. When power-down mode is terminated by RESET, a normal reset operation is executed. Assuming that both the interrupt enable flag and the interrupt request flag are set to "1", power-down mode is released immediately upon entering power-down mode. Sub stop mode can be terminated by RESET only.

When an interrupt is used to release power-down mode, the operation differs depending on the value of the interrupt master enable flag (IME):

- If the IME flag = "0", program execution starts immediately after the instruction issuing a request to enter power-down mode is executed. The interrupt request flag remains set to logical one.
- If the IME flag = "1", two instructions are executed after the power-down mode release and the vectored interrupt is then initiated. However, when the release signal is caused by INT2 or INTW, the operation is identical to the IME = "0" condition. Assuming that both interrupt enable flag and interrupt request flag are set to "1", the release signal is generated when power-down mode is entered.

Table 8-1. Hardware Operation During Power-Down Modes

Mode	Main Stop	Sub Stop	Main/Sub Stop	Idle
System clock	Main clock (fx)	Sub clock (fxt)	Main clock (fx) <sup>(1)</sup>	Main (fx) or sub clock (fxt)
Instruction	STOP	Setting SCMOD.2 to "1"	STOP	IDLE
Clock oscillator	Main clock oscillation stops	Sub clock oscillation stops	Main clock oscillation stops	Only CPU clock stops. <sup>(2)</sup>
Basic timer	Basic timer stops.	Basic timer stops.	Basic timer stops.	Basic timer operates.
Timer/counter 0	Operates only if TCL0 is selected as counter clock.	Operates only if TCL0 is selected as counter clock.	Operates only if TCL0 is selected as counter clock.	Timer/counter 0 operates.
Watch timer	Operates only if sub clock (fxt) is selected as counter clock.	Watch timer stops.	Watch timer stops.	Watch timer operates.
LCD controller	Operates only if sub clock (fxt) is selected as LCD clock, LCDCK.	LCD controller stops.	LCD controller stops.	LCD controller operates.
External interrupts	INT1 and INT2 are acknowledged; INT0 is not serviced.	INT0, INT1, and INT2 is not serviced.	INT1 and INT2 are acknowledged; INT0 is not serviced.	INT1 and INT2 are acknowledged; INT0 is not serviced.
CPU	All CPU operations are disabled.			
Mode release signal	Interrupt request signals (except INT0) pre-enabled by IEx or RESET input.	Only RESET input	Interrupt request signals (except INT0) pre-enabled by IEx or RESET input.	

**NOTE:** 1. Sub clock stops by setting SCMOD.2 to "1".  
2. Main and sub clock oscillation continues.

## IDLE MODE TIMING DIAGRAMS

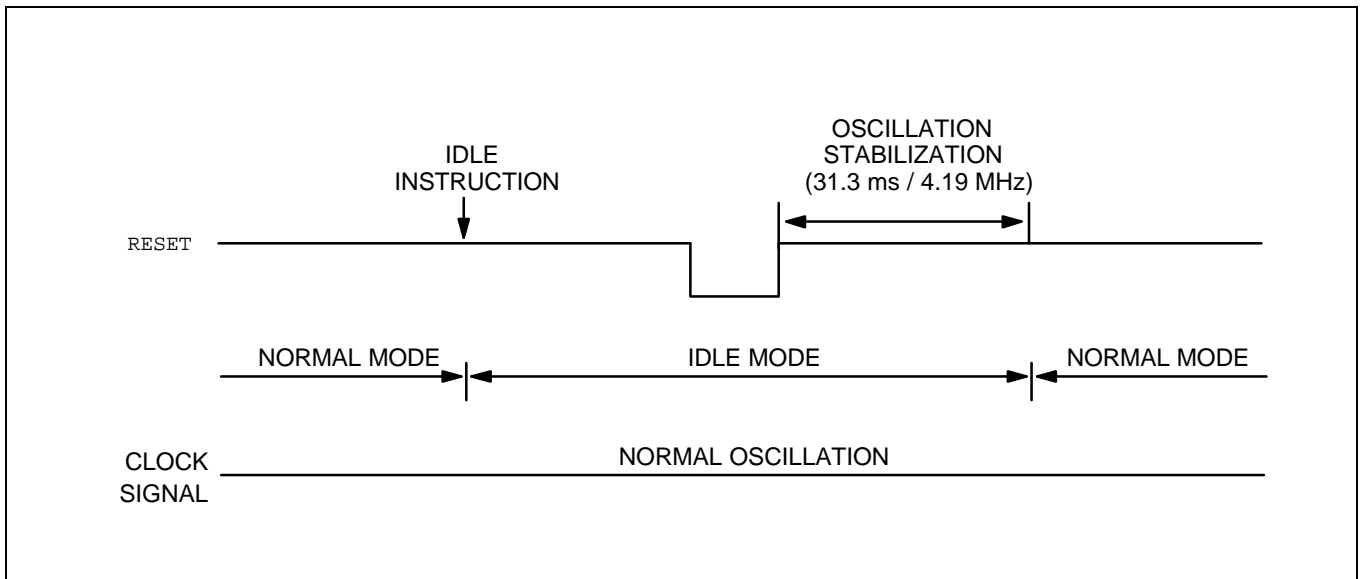

Figure 8-1. Timing When Idle Mode is Released by RESET

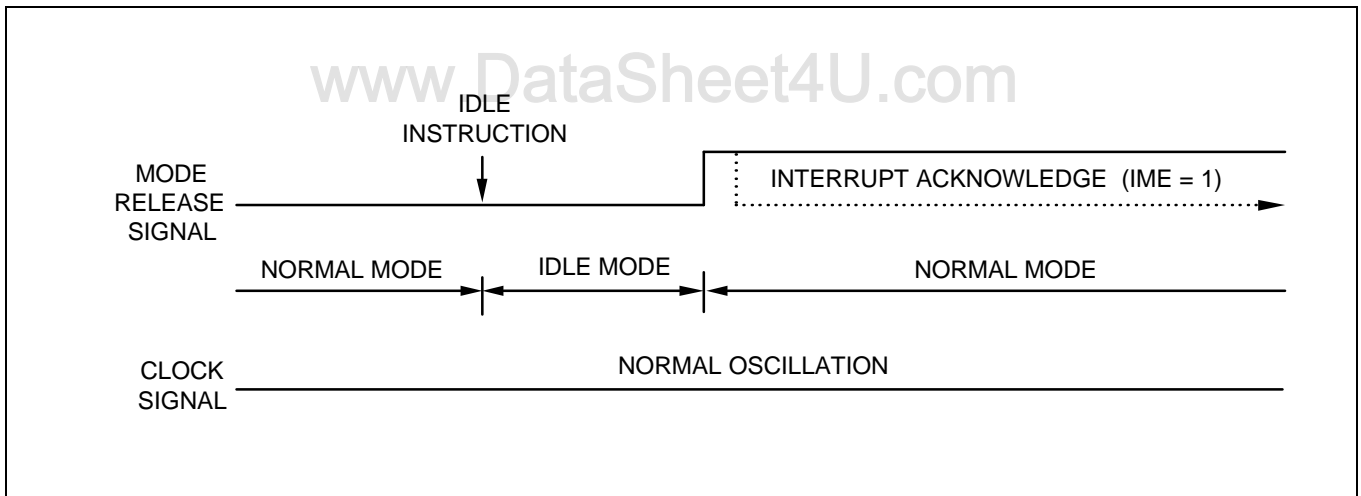

Figure 8-2. Timing When Idle Mode is Released by an Interrupt

## STOP MODE TIMING DIAGRAMS

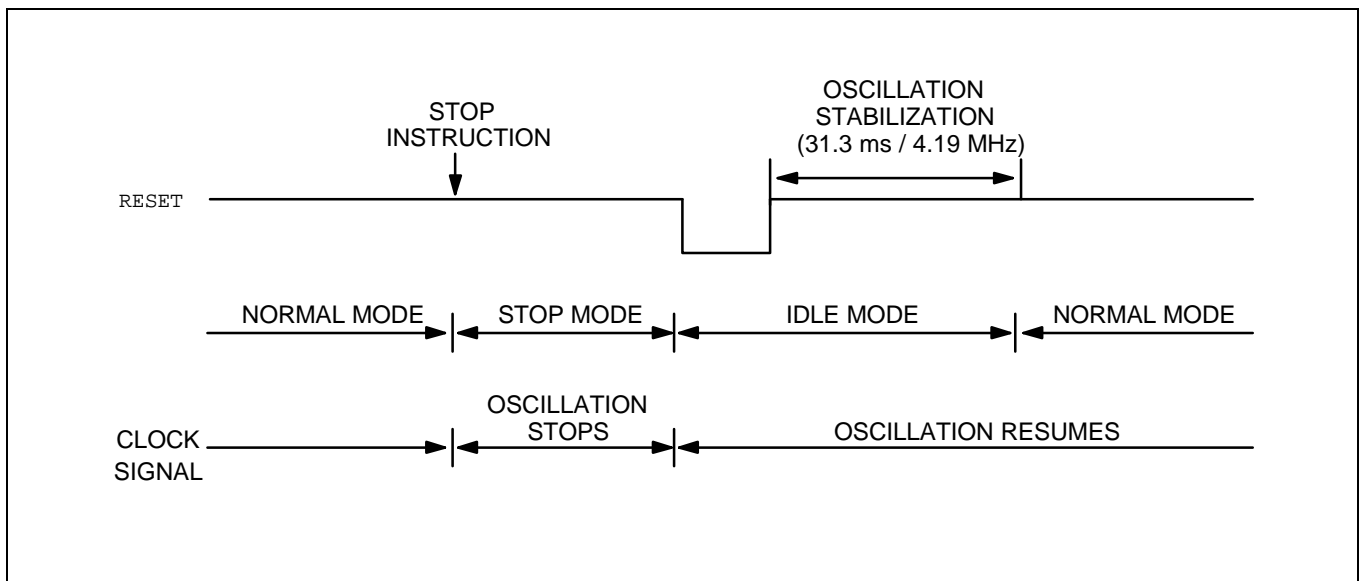

Figure 8-3. Timing When Stop Mode is Released by RESET

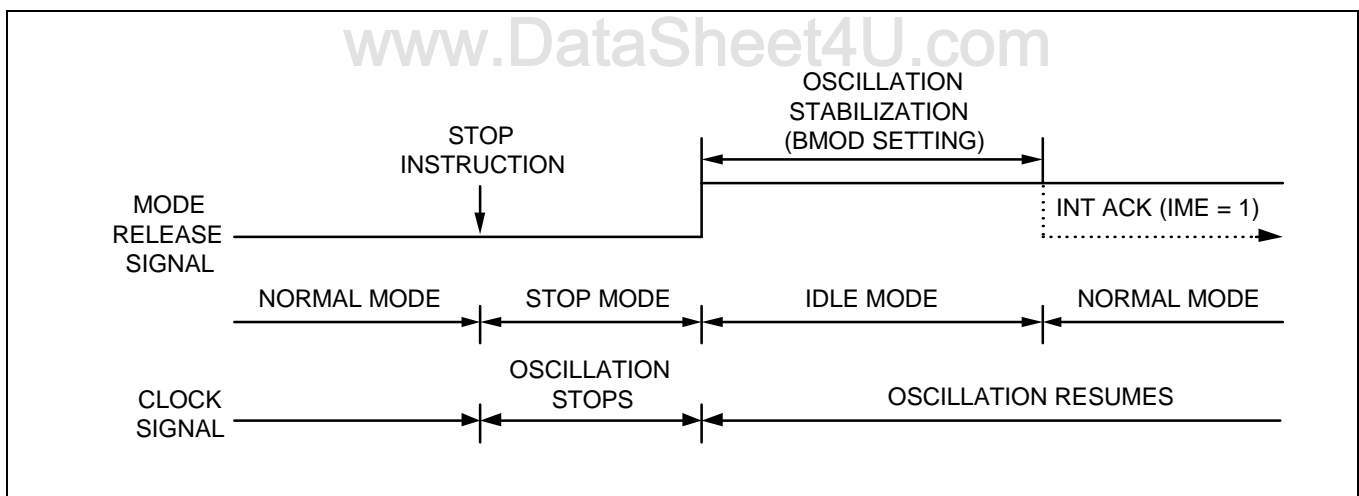

Figure 8-4. Timing When Main Stop or Main/Sub Stop Mode is Release by an Interrupt

### PROGRAMMING TIP — Reducing Power Consumption for Key Input Interrupt Processing

The following code shows real-time clock and interrupt processing for key inputs to reduce power consumption. In this example, the system clock source is switched from the main system clock to a subsystem clock and the LCD display is turned on:

```

KEYCLK    DI
          CALL    MA2SUB          ; Main system clock → subsystem clock switch subroutine
          SMB     15
          LD      EA,#00H
          LD      P2,EA          ; All key strobe outputs to low level
          LD      A,#3H
          LD      IMOD2,A       ; Select KS0–KS3 enable
          SMB     0
          BITR    IRQW
          BITR    IRQ2
          BITS    IEW
          BITS    IE2
CLKS1     CALL    WATDIS         ; Execute clock and display changing subroutine
          BTSTZ   IRQ2
          JR      CIDLE
          CALL    SUB2MA         ; Subsystem clock → main system clock switch
subroutine
          EI
          RET
CIDLE     IDLE                   ; Engage idle mode
          NOP
          NOP
          NOP
          JPS     CLKS1

```

#### NOTE

You must execute three NOP instructions after IDLE and STOP instructions, to avoid flowing of leakage current due to the floating state in the internal bus.



**PORT PIN CONFIGURATION FOR POWER-DOWN**

The following method describes how to configure I/O port pins to reduce power consumption during power-down modes (stop, idle):

**Condition 1:** If the microcontroller is not configured to an external device:

1. Connect unused port pins according to the information in Table 8-2.
2. Disable pull-up resistors for input pins configured to  $V_{DD}$  or  $V_{SS}$  levels in order to check the current input option. Reason: If the input level of a port pin is set to  $V_{SS}$  when a pull-up resistor is enabled, it will draw an unnecessarily large current.

**Condition 2:** If the microcontroller is configured to an external device and the external device's  $V_{DD}$  source is turned off in power-down mode.

1. Connect unused port pins according to the information in Table 8-2.
2. Disable pull-up resistors for input pins configured to  $V_{DD}$  or  $V_{SS}$  levels in order to check the current input option. Reason: If the input level of a port pin is set to  $V_{SS}$  when a pull-up resistor is enabled, it will draw an unnecessarily large current.
3. Disable the pull-up resistors of input pins connected to the external device by making the necessary modifications to the PUMOD register.
4. Configure the output pins that are connected to the external device to low level. Reason: When the external device's  $V_{DD}$  source is turned off, and if the microcontroller's output pins are set to high level,  $V_{DD} - 0.7$  V is supplied to the  $V_{DD}$  of the external device through its input pin. This causes the device to operate at the level  $V_{DD} - 0.7$  V. In this case, total current consumption would not be reduced.
5. Determine the correct output pin state necessary to block current pass in according with the external transistors (PNP, NPN).

## RECOMMENDED CONNECTIONS FOR UNUSED PINS

To reduce overall power consumption, please configure unused pins according to the guidelines described in Table 8-2.

**Table 8-2. Unused Pin Connections for Reducing Power Consumption**

Pin/Share Pin Names	Recommended Connection
P1.0/INT0 P1.1/INT1 P1.2/INT2 P1.3/TCL0	Connect to $V_{DD}$ <sup>(1)</sup>
P2.0/TCLO0 P2.1 P2.2/CLO P2.3/BUZ	Input mode: Connect to $V_{DD}$ Output mode: No connection
P3.2–P3.3 P3.1/LCDSY P3.0/LCDCK	Input mode: Connect to $V_{DD}$ Output mode: No connection
P8.0/SEG24–P8.7/SEG31	No connection <sup>(2)</sup>
SEG0–SEG23 COM0–COM3	No connection
$V_{LC0}$ – $V_{LC2}$	No connection
$XT_{in}$	Connect $XT_{in}$ to $V_{SS}$ and set SCMOD.2 to "1"
$XT_{out}$	No connection
TEST	Connect to $V_{SS}$

### NOTES:

1. Digital mode at P1.0 and P1.1
2. Used as segment

NOTES

www.DataSheet4U.com

# 9

## RESET

### OVERVIEW

When a RESET signal is input during normal operation or power-down mode, a hardware reset operation is initiated and the CPU enters idle mode. Then, when the standard oscillation stabilization interval of 31.3 ms at 4.19 MHz has elapsed, normal system operation resumes.

Regardless of when the RESET occurs — during normal operating mode or during a power-down mode — most hardware register values are set to the reset values described in Table 9-1. The current status of several register values is, however, always retained when a RESET occurs during idle or stop mode; If a RESET occurs during normal operating mode, their values are undefined. Current values that are retained in this case are as follows:

- Carry flag
- Data memory values
- General-purpose registers E, A, L, H, X, W, Z, and Y

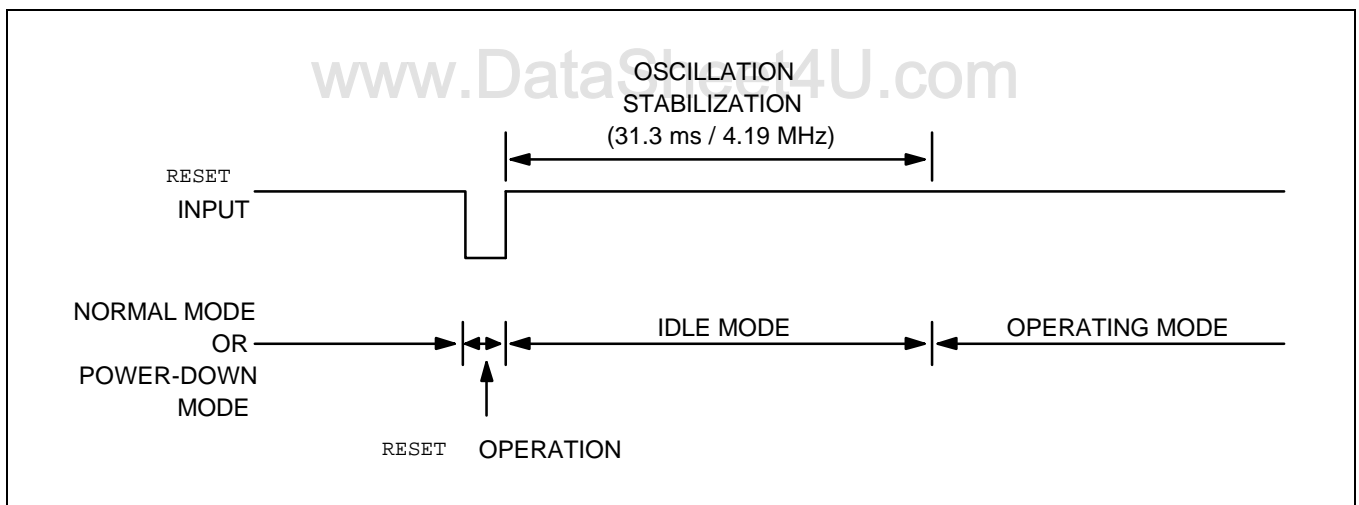

Figure 9-1. Timing for Oscillation Stabilization After RESET

### HARDWARE REGISTER VALUES AFTER RESET

Table 9-1 gives you detailed information about hardware register values after a RESET occurs during power-down mode or during normal operation.

Table 9-1. Hardware Register Values After RESET

Hardware Component or Subcomponent	If RESET Occurs During Power-Down Mode	If RESET Occurs During Normal Operation
Program counter (PC)	Lower four bits of address 0000H are transferred to PC11–8, and the contents of 0001H to PC7–0.	Lower four bits of address 0000H are transferred to PC11–8, and the contents of 0001H to PC7–0.
<b>Program Status Word (PSW):</b>		
Carry flag (C)	Retained	Undefined
Skip flag (SC0–SC2)	0	0
Interrupt status flags (IS0, IS1)	0	0
Bank enable flags (EMB, ERB)	Bit 6 of address 0000H in program memory is transferred to the ERB flag, and bit 7 of the address to the EMB flag.	Bit 6 of address 0000H in program memory is transferred to the ERB flag, and bit 7 of the address to the EMB flag.
Stack pointer (SP)	Undefined	Undefined
<b>Data Memory (RAM):</b>		
Working registers E, A, L, H, X, W, Z, Y	Values retained	Undefined
General-purpose registers	Values retained	Undefined
Bank selection registers (SMB, SRB)	0, 0	0, 0
BSC register (BSC0–BSC3)	0	0
<b>Clocks:</b>		
Power control register (PCON)	0	0
Clock output mode register (CLMOD)	0	0
System clock control reg (SCMOD)	0	0
<b>Interrupts:</b>		
Interrupt request flags (IRQx)	0	0
Interrupt enable flags (IEx)	0	0
Interrupt priority flag (IPR)	0	0
Interrupt master enable flag (IME)	0	0
INT0 mode register (IMOD0)	0	0
INT1 mode register (IMOD1)	0	0
INT2 mode register (IMOD2)	0	0

Table 9-1. Hardware Register Values After RESET (Continued)

Hardware Component or Subcomponent	If RESET Occurs During Power-Down Mode	If RESET Occurs During Normal Operation
<b>I/O Ports:</b>		
Output buffers	Off	Off
Output latches	0	0
Port mode flags (PM)	0	0
Pull-up resistor mode reg (PUMOD)	0	0
<b>Basic Timer:</b>		
Count register (BCNT)	Undefined	Undefined
Mode register (BMOD)	0	0
<b>Timer/Counter 0:</b>		
Count registers (TCNT0)	0	0
Reference registers (TREF0)	FFH	FFH
Mode registers (TMOD0)	0	0
Output enable flags (TOE0)	0	0
<b>Watchdog Timer:</b>		
WDT mode register (WDMOD)	A5H	A5H
WDT clear flag (WDTCF)	0	0
<b>Watch Timer:</b>		
Watch timer mode register (WMOD)	0	0
<b>LCD Driver/Controller:</b>		
LCD mode register (LMOD)	0	0
LCD control register (LCON)	0	0
Display data memory	Values retained	Undefined
Output buffers	Off	Off

## NOTES

www.DataSheet4U.com

# 10

## I/O PORTS

### OVERVIEW

The KS57C2302/C2304 has 5 ports. There are total of 4 input pins, 8 output pins and 12 configurable I/O pins, for a maximum number of 24 pins.

Pin addresses for all ports are mapped to bank 15 of the RAM. The contents of I/O port pin latches can be read, written, or tested at the corresponding address using bit manipulation instructions.

### Port Mode Flags

Port mode flags (PM) are used to configure I/O ports to input or output mode by setting or clearing the corresponding I/O buffer.

### Pull-Up Resistor Mode Register (PUMOD)

The pull-up mode registers (PUMOD) are used to assign internal pull-up resistors by software to specific ports. When a configurable I/O port pin is used as an output pin, its assigned pull-up resistor is automatically disabled, even though the pin's pull-up is enabled by a corresponding PUMOD bit setting.

www.DataSheet4U.com



Table 10-1. I/O Port Overview

Port	I/O	Pins	Pin Names	Address	Function Description
1	I	4	P1.0–P1.3	FF1H	4-bit input port. 1-bit and 4-bit read and test is possible. 4-bit pull-up resistors are software assignable.
2	I/O	4	P2.0–P2.3	FF2H	4-bit I/O port. 1-bit and 4-bit read/write and test is possible. 4-bit pull-up resistors are software assignable.
3	I/O	4	P3.0–P3.3	FF3H	4-bit I/O port. Port 3 pins are individually software configurable as input or output. 1-, and 4-bit read/write/test is possible. 4-bit pull-up resistors are software assignable.
6	I/O	4	P6.0–P6.3	FF6H	4-bit I/O port. Port 6 pins are individually software configurable as input or output. 1-, and 4-bit read/write/test is possible. 4-bit pull-up resistors are software assignable.
8	O	8	P8.0–P8.7	1F8H–1FFH	Output port for 1-bit data (for use as CMOS driver only)

Table 10-2. Port Pin Status During Instruction Execution

Instruction Type	Example	Input Mode Status	Output Mode Status
1-bit test 1-bit input 4-bit input	BTST P0.1 LDB C,P1.3 LD A,P1	Input or test data at each pin	Input or test data at output latch
1-bit output	BITR P2.3	Output latch contents undefined	Output pin status is modified
4-bit output	LD P2,A	Transfer accumulator data to the output latch	Transfer accumulator data to the output pin

## PORT MODE FLAGS (PM FLAGS)

Port mode flags (PM) are used to configure I/O ports to input or output mode by setting or clearing the corresponding I/O buffer.

For convenient program reference, PM flags are organized into two groups — PMG1 and PMG2 as shown in Table 10-3. They are addressable by 8-bit write instructions only.

When a PM flag is "0", the port is set to input mode; when it is "1", the port is enabled for output. RESET clears all port mode flags to logical zero, automatically configuring the corresponding I/O ports to input mode.

**Table 10-3. Port Mode Group Flags**

PM Group ID	Address	Bit 3	Bit 2	Bit 1	Bit 0
PMG1	FE8H	PM3.3	PM3.2	PM3.1	PM3.0
	FE9H	PM6.3	PM6.2	PM6.1	PM6.0
PMG2	FECH	"0"	PM2	"0"	"0"
	FEDH	"0"	"0"	"0"	"0"

### PROGRAMMING TIP — Configuring I/O Ports to Input or Output

Configure ports 3 and 6 as an output port:

```

BITS      EMB
SMB       15
LD        EA,#0FFH
LD        PMG1,EA          ; P3 and P6 ← Output
  
```

## PULL-UP RESISTOR MODE REGISTER (PUMOD)

The pull-up resistor mode register (PUMOD) is used to assign internal pull-up resistors by software to specific ports. When a configurable I/O port pin is used as an output pin, its assigned pull-up resistor is automatically disabled, even though the pin's pull-up is enabled by a corresponding PUMOD bit setting.

PUMOD is addressable by 8-bit write instructions only. RESET clears PUMOD register values to logic zero, automatically disconnecting all software-assignable port pull-up resistors.

**Table 10-4. Pull-Up Resistor Mode Register (PUMOD) Organization**

PUMOD ID	Address	Bit 3	Bit 2	Bit 1	Bit 0
PUMOD	FDCH	PUR3	PUR2	PUR1	"0"
	FDDH	"0"	PUR6	"0"	"0"

**NOTE:** When bit = "1", a pull-up resistor is assigned to the corresponding I/O port: PUR3 for port 3, PUR2 for port 2, and so on.

### PROGRAMMING TIP — Enabling and Disabling I/O Port Pull-Up Resistors

P2 and P3 are enabled to have pull-up resistors.

```

BITS      EMB
SMB       15
LD        EA,#0CH
LD        PUMOD,EA           ; Enable P2 and P3 to have pull-up resistors
  
```

### PIN ADDRESSING FOR OUTPUT PORT 8

The addresses for the port 8 1-bit output pin buffers are located in bank 1 of data memory instead of bank 15. To address port 8 output pins, use the settings EMB = 1 and SMB = 1. The LCD mode register, LMOD is used to control whether the pin address is used for LCD data output or for normal data output:

**Table 10-5. LMOD.7 and LMOD.6 Setting for Port 8 Output Control**

LMOD.7	LMOD.6	LCD Output Segments	1-Bit Output Pins
0	0	Seg 24–31	–
0	1	Seg 24–27	P8.4–P8.7 (Seg 28–31)
1	0	Seg 28–31	P8.0–P8.3 (Seg 24–27)
1	1	–	P8.0–P8.7 (Seg 24–31)

Each address in RAM bank 1 corresponds to a 4-bit register location. The LSB (bit 0) of the register location is used as the port buffer for either LCD segment output or normal 1-bit data output. Locations that are unused for LCD or port I/O can be used as normal data memory. After a RESET, the values contained in the port 8 output buffer are left undetermined.

Table 10-6 shows port 8 pin addresses and also the corresponding LCD segment names if the pins are used to output LCD segment data. Pin addresses that are not used for LCD segment output can be used for normal 1-bit output.

**Table 10-6. Port 8 Pin Addresses and LCD Segment Correspondence**

Port 8 Pin Number	RAM Address	LCD Segment
P8.0	1F8H	SEG24
P8.1	1F9H	SEG25
P8.2	1FAH	SEG26
P8.3	1FBH	SEG27
P8.4	1FCH	SEG28
P8.5	1FDH	SEG29
P8.6	1FEH	SEG30
P8.7	1FFH	SEG31

PORT 1 CIRCUIT DIAGRAM

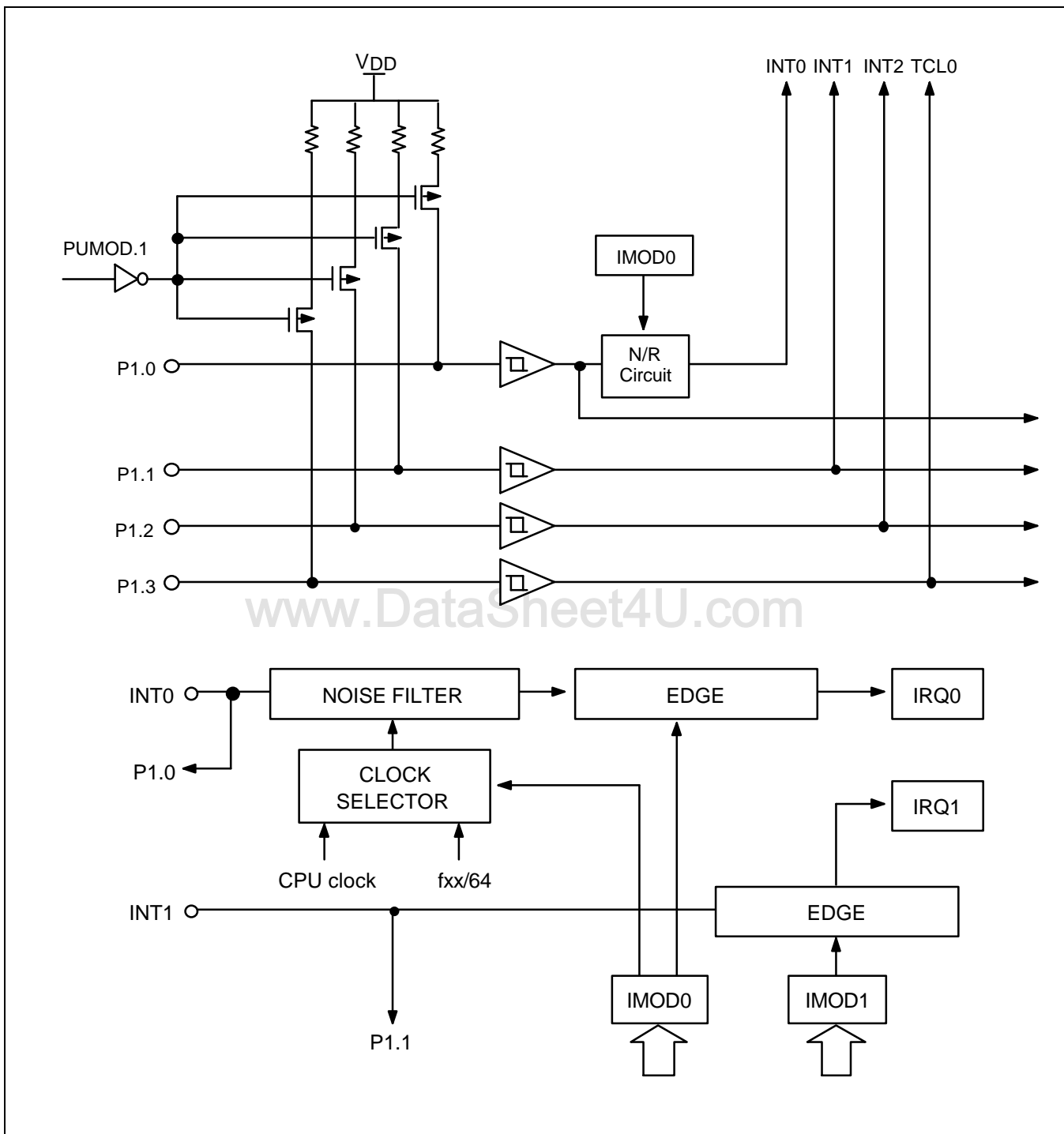

Figure 10-1. Input Port 1 Circuit Diagram

## PORT 2 CIRCUIT DIAGRAM

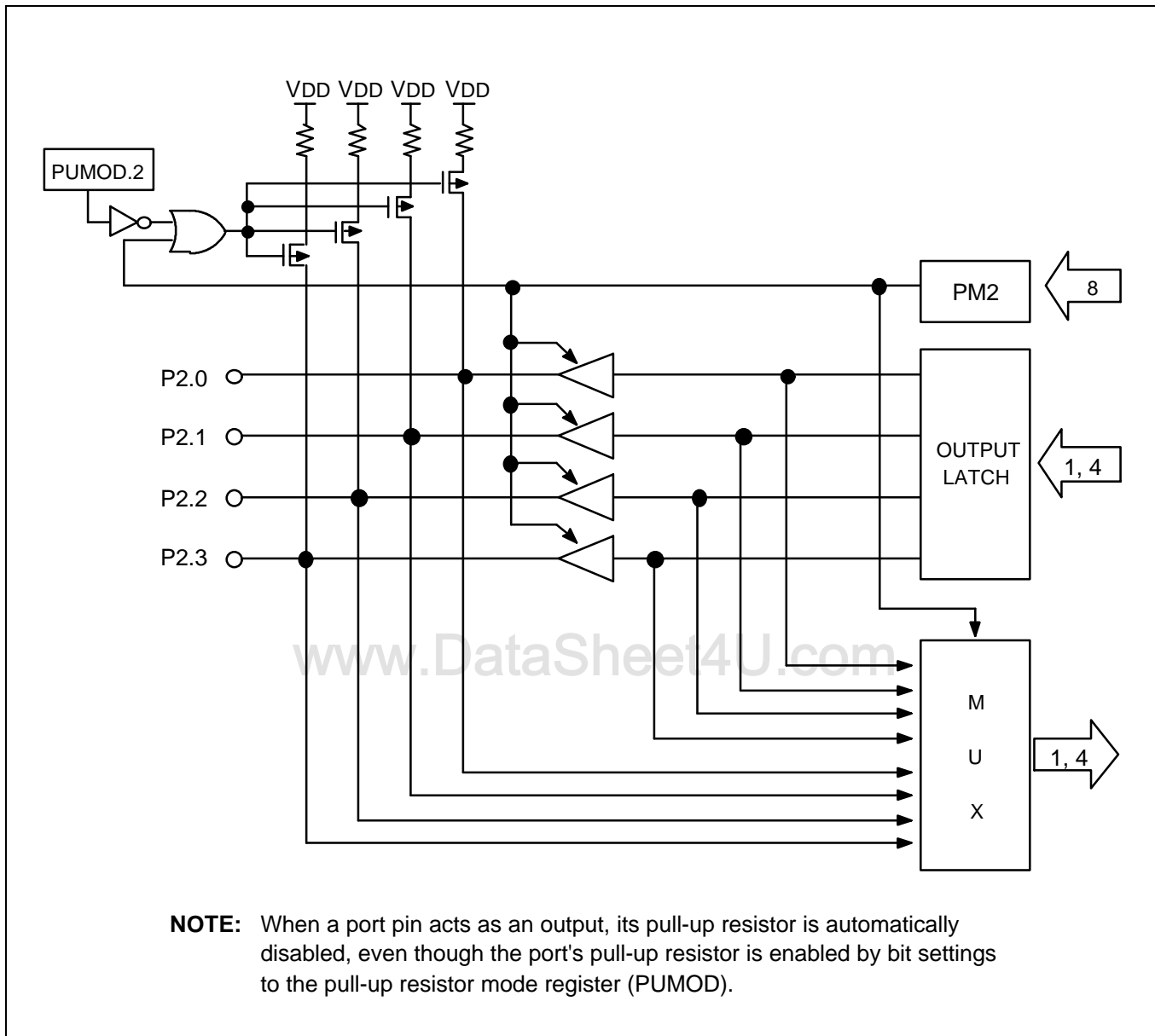

Figure 10-2. Port 2 Circuit Diagram

## PORTS 3 AND 6 CIRCUIT DIAGRAM

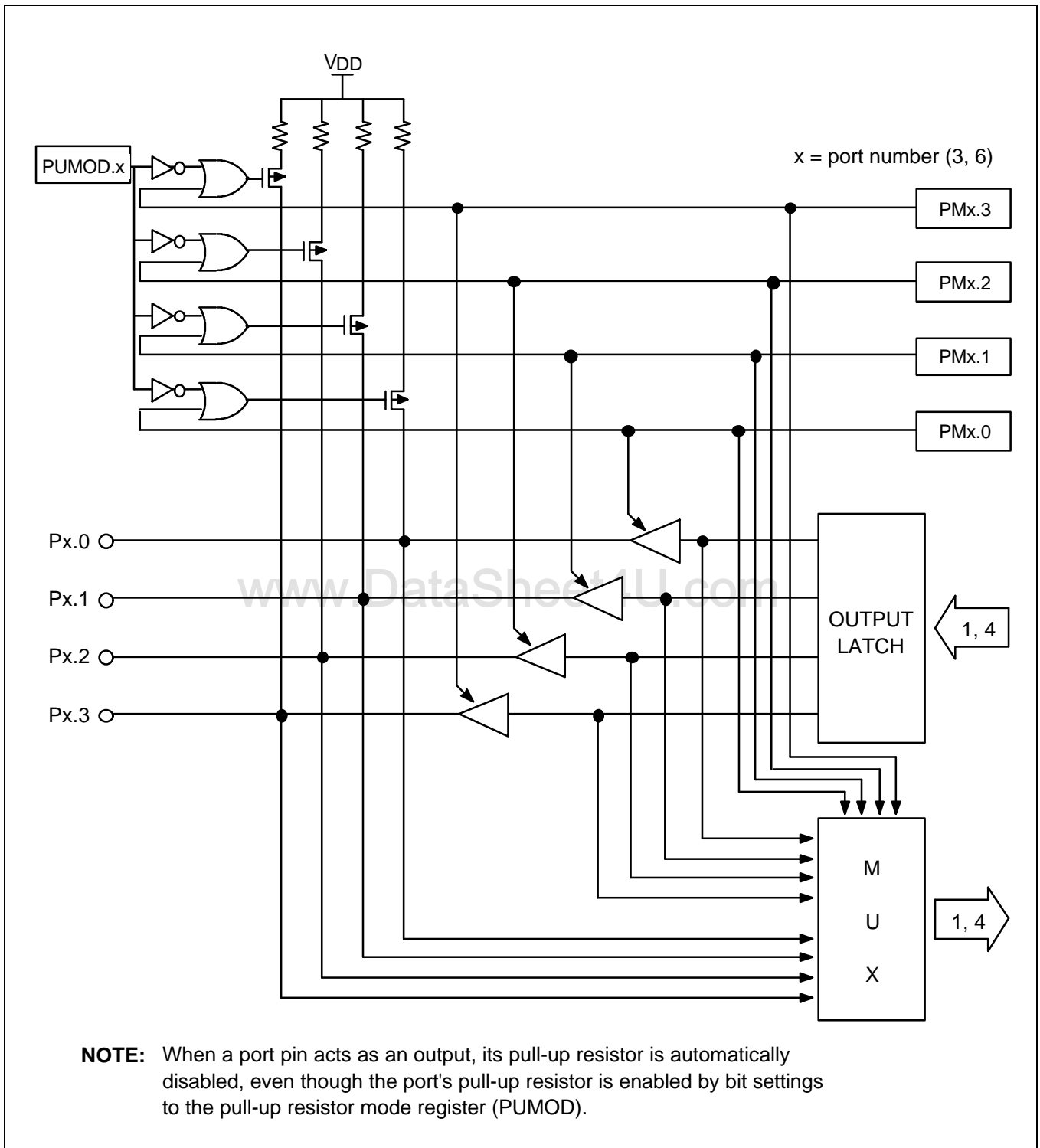

Figure 10-3. Ports 3 and 6 Circuit Diagram

**NOTES**

www.DataSheet4U.com

# 11

## TIMERS and TIMER/COUNTERS

### OVERVIEW

The KS57C2302/C2304 microcontroller has three timer and timer/counter modules:

- 8-bit basic timer (BT)
- 8-bit timer/counter (TC0)
- Watch timer (WT)

The 8-bit basic timer (BT) is the microcontroller's main interval timer. It generates an interrupt request at a fixed time interval when the appropriate modification is made to its mode register. The basic timer also functions as 'watchdog' timer and is used to determine clock oscillation stabilization time when stop mode is released by an interrupt and after a RESET.

The 8-bit timer/counter (TC0) is programmable timer/counter that is used primarily for event counting and for clock frequency modification and output.

The watch timer (WT) module consists of an 8-bit watch timer mode register, a clock selector, and a frequency divider circuit. Watch timer functions include real-time and watch-time measurement, main and subsystem clock interval timing, buzzer output generation. It also generates a clock signal for the LCD controller.



## BASIC TIMER (BT)

### OVERVIEW

The 8-bit basic timer (BT) has five functional components:

- Clock selector logic
- 4-bit mode register (BMOD)
- 8-bit counter register (BCNT)
- 8-bit watchdog timer mode register (WDMOD)
- Watchdog timer counter clear flag (WDTCF)

The basic timer generates interrupt requests at precise intervals, based on the frequency of the system clock. Basic timer's counter register, BCNT, outputs timer pulses to the watchdog timer's counter register, WDTCNT when an overflow occurs in BCNT. You can use the basic timer as a "watchdog" timer for monitoring system events or use BT output to stabilize clock oscillation when stop mode is released by an interrupt and following RESET. Bit settings in the basic timer mode register BMOD turns the BT on and off, selects the input clock frequency, and controls interrupt or stabilization intervals.

### Interval Timer Function

The measurement of elapsed time intervals is the basic timer's primary function. The standard interval is 256 BT clock pulses.

To restart the basic timer, set bit 3 of the mode register BMOD to logic one. The input clock frequency and the interrupt and stabilization interval are selected by loading the appropriate bit values to BMOD.2–BMOD.0.

The 8-bit counter register, BCNT, is incremented each time a clock signal is detected that corresponds to the frequency selected by BMOD. BCNT continues incrementing as it counts BT clocks until an overflow occurs. An overflow causes the BT interrupt request flag (IRQB) to be set to logic one to signal that the designated time interval has elapsed. An interrupt request is then generated, BCNT is cleared to logic zero, and counting continues from 00H.

### Oscillation Stabilization Interval Control

Bits 2–0 of the BMOD register are used to select the input clock frequency for the basic timer. This setting also determines the time interval (also referred to as 'wait time') required to stabilize clock signal oscillation when power-down mode is released by an interrupt. When a RESET signal is generated, the standard stabilization interval for system clock oscillation following a RESET is 31.3 ms at 4.19 MHz.

### Watchdog Timer Function

The basic timer can also be used as a "watchdog" timer to detect an inadvertent program loop, that is, system or program operation error. For this purpose, instruction that clears the watchdog timer (BITS WDTCF) within a given period should be executed at proper points in a program. If an instruction that clears the watchdog timer is not done within the period and the watchdog timer overflows, reset signal is generated and system is restarted with reset status. An operation of watchdog timer is as follows:

- Write some value (except #5AH) to Watchdog Timer Mode register, WDMOD.
- Each time BCNT overflows, an overflow signal is sent to the watchdog timer counter, WDCNT.
- If WDTCNT overflows, system reset will be generated.

Table 11-1. Basic Timer Register Overview

Register Name	Type	Description	Size	RAM Address	Addressing Mode	Reset Value
BMOD	Control	Controls the clock frequency (mode) of the basic timer; also, the oscillation stabilization interval after power-down mode release or RESET	4-bit	F85H	4-bit write-only; BMOD.3: 1-bit write-only	"0"
BCNT	Counter	Counts clock pulses matching the BMOD frequency setting	8-bit	F86H–F87H	8-bit read-only	"u" (note)
WDMOD	Control	Controls watchdog timer operation.	8-bit	F98H–F99H	8-bit write-only	A5H
WDTCF	Control	Clear the watchdog timer's counter.	1-bit	F9AH.3	1-bit write-only	"0"

**NOTE:** "u" means that the value is undetermined after a RESET.

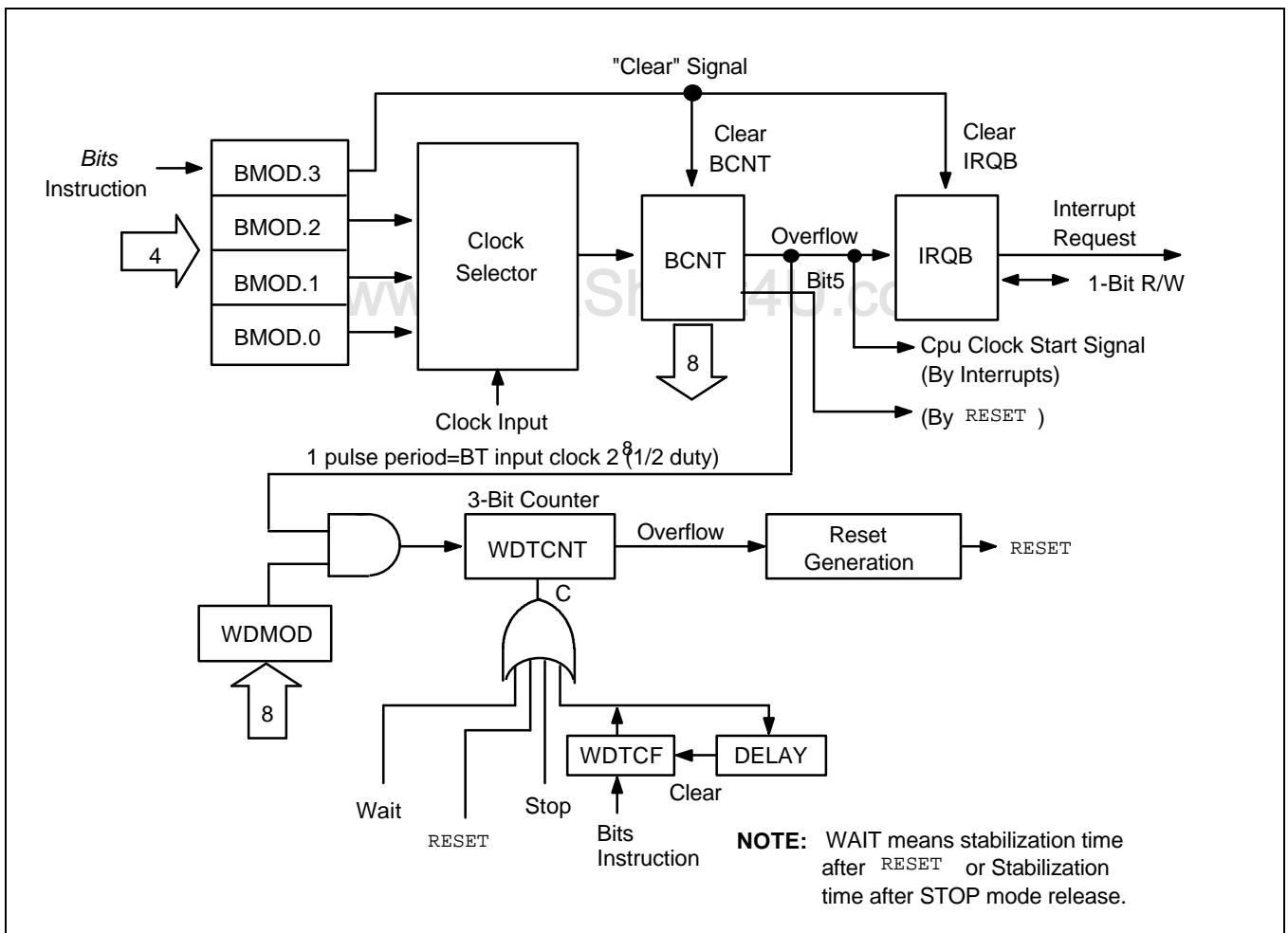

Figure 11-1. Basic Timer Circuit Diagram

**BASIC TIMER MODE REGISTER (BMOD)**

The basic timer mode register, BMOD, is a 4-bit write-only register. Bit 3, the basic timer start control bit, is also 1-bit addressable. All BMOD values are set to logic zero following RESET and interrupt request signal generation is set to the longest interval. (BT counter operation cannot be stopped.) BMOD settings have the following effects:

- Restart the basic timer;
- Control the frequency of clock signal input to the basic timer;
- Determine time interval required for clock oscillation to stabilize following the release of stop mode by an interrupt.

By loading different values into the BMOD register, you can dynamically modify the basic timer clock frequency during program execution. Four BT frequencies, ranging from  $f_{xx}/2^{12}$  to  $f_{xx}/2^5$ , are selectable. Since BMOD's reset value is logic zero, the default clock frequency setting is  $f_{xx}/2^{12}$ .

The most significant bit of the BMOD register, BMOD.3, is used to restart the basic timer. When BMOD.3 is set to logic one (enabled) by a 1-bit write instruction, the contents of the BT counter register (BCNT) and the BT interrupt request flag (IRQB) are both cleared to logic zero, and timer operation is restarted.

The combination of bit settings in the remaining three registers — BMOD.2, BMOD.1, and BMOD.0 — determines the clock input frequency and oscillation stabilization interval.

**Table 11-2. Basic Timer Mode Register (BMOD) Organization**

<b>BMOD.3</b>	<b>Basic Timer Restart Bit</b>
1	Restart basic timer; clear IRQB, BCNT, and BMOD.3 to "0"

BMOD.2	BMOD.1	BMOD.0	Basic Timer Input Clock	Interval Time
0	0	0	$f_{xx}/2^{12}$ (1.02 kHz)	$2^{20}/f_{xx}$ (250 ms)
0	1	1	$f_{xx}/2^9$ (8.18 kHz)	$2^{17}/f_{xx}$ (31.3 ms)
1	0	1	$f_{xx}/2^7$ (32.7 kHz)	$2^{15}/f_{xx}$ (7.82 ms)
1	1	1	$f_{xx}/2^5$ (131 kHz)	$2^{13}/f_{xx}$ (1.95 ms)

**NOTES:**

1. Clock frequencies and stabilization intervals assume a system oscillator clock frequency ( $f_{xx}$ ) of 4.19 MHz.
2.  $f_{xx}$  = selected system clock frequency.
3. Oscillation stabilization time is the time required to stabilize clock signal oscillation after stop mode is released. The data in the table column 'Oscillation Stabilization' can also be interpreted as "Interrupt Interval Time."
4. The standard stabilization time for system clock oscillation following a RESET is 31.3 ms at 4.19 MHz.

### BASIC TIMER COUNTER (BCNT)

BCNT is an 8-bit counter for the basic timer. It can be addressed by 8-bit read instructions.

RESET leaves the BCNT counter value undetermined. BCNT is automatically cleared to logic zero whenever the BMOD register control bit (BMOD.3) is set to "1" to restart the basic timer. It is incremented each time a clock pulse of the frequency determined by the current BMOD bit settings is detected.

When BCNT has incremented to hexadecimal 'FFH' (255 clock pulses), it is cleared to '00H' and an overflow is generated. The overflow causes the interrupt request flag, IRQB, to be set to logic one. When the interrupt request is generated, BCNT immediately resumes counting with incoming clock signal.

#### NOTE

Always execute a BCNT read operation twice to eliminate the possibility of reading unstable data while the counter is incrementing. If, after two consecutive reads, the BCNT values match, you can select the latter value as valid data. Until the results of the consecutive reads match, however, the read operation must be repeated until the validation condition is met.

### BASIC TIMER OPERATION SEQUENCE

The basic timer's sequence of operations may be summarized as follows:

1. Set counter buffer bit (BMOD.3) to logic one to restart the basic timer.
2. BCNT is then incremented by one per each clock pulse corresponding to BMOD selection.
3. BCNT overflows if BCNT = 255 (BCNT = FFH).
4. When an overflow occurs, the IRQB flag is set by hardware to logic one.
5. The interrupt request is generated.
6. BCNT is then cleared by hardware to logic zero.
7. Basic timer resumes counting clock pulses.

### PROGRAMMING TIP — Using the Basic Timer

1. To read the basic timer count register (BCNT):

```

        BITS      EMB
        SMB      15
BCNTR  LD        EA,BCNT
        LD        YZ,EA
        LD        EA,BCNT
        CPSE     EA,YZ
        JR        BCNTR
  
```

2. When stop mode is released by an interrupt, set the oscillation stabilization interval to 31.3 ms:

```

        BITS      EMB
        SMB      15
        LD        A,#0BH
        LD        BMOD,A           ; Wait time is 31.3 ms
        NOP
        STOP                    ; Set stop power-down mode
        NOP
        NOP
        NOP
  
```

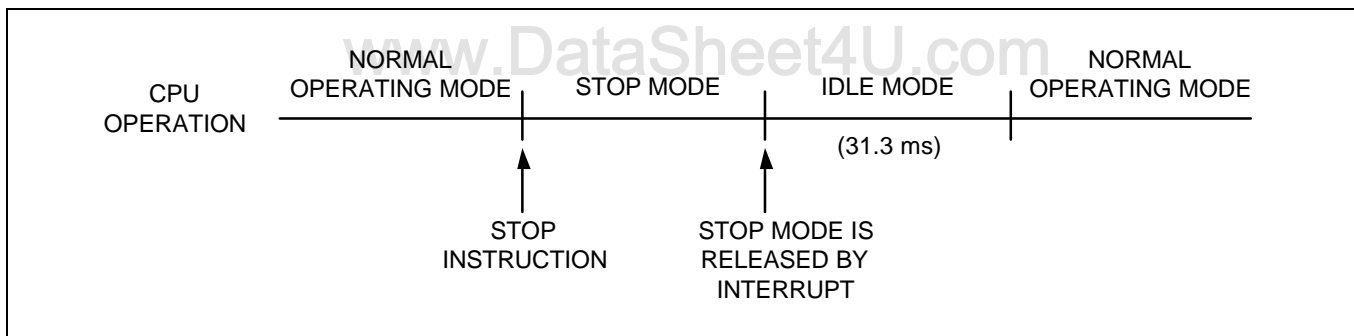

3. To set the basic timer interrupt interval time to 1.95 ms (at 4.19 MHz):

```

        BITS      EMB
        SMB      15
        LD        A,#0FH
        LD        BMOD,A
        EI
        BITS      IEB           ; Basic timer interrupt enable flag is set to "1"
  
```

4. Clear BCNT and the IRQB flag and restart the basic timer:

```

        BITS      EMB
        SMB      15
        BITS      BMOD.3
  
```

**WATCHDOG TIMER MODE REGISTER (WDMOD)**

The watchdog timer mode register, WDMOD, is a 8-bit write-only register located at RAM address F98H–F99H. WDMOD register controls to enable or disable the watchdog function. WDMOD values are set to logic “A5H” following RESET and this value enables the watchdog timer, and watchdog timer is set to the longest interval because BT overflow signal is generated with the longest interval.

WDMOD	Watchdog Timer Enable/Disable Control
5AH	Disable watchdog timer function
Any other value	Enable watchdog timer function

**WATCHDOG TIMER COUNTER (WDCNT)**

The watchdog timer counter, WDCNT, is a 3-bit counter. WDCNT is automatically cleared to logic zero, and restarts whenever the WDTCF register control bit is set to “1”. RESET, stop, and wait signal clears the WDCNT to logic zero also.

WDCNT increments each time a clock pulse of the overflow frequency determined by the current BMOD bit setting is generated. When WDCNT has incremented to hexadecimal ‘07H’, it is cleared to ‘00H’ and an overflow is generated. The overflow causes the system RESET. When the interrupt request is generated, BCNT immediately resumes counting incoming clock signals.

**WATCHDOG TIMER COUNTER CLEAR FLAG (WDTCF)**

The watchdog timer counter clear flag, WDTCF, is a 1-bit write instruction. When WDTCF is set to one, it clears the WDCNT to zero and restarts the WDCNT. WDTCF register bits 2–0 are always logic zero.

**Table 11-3. Watchdog Timer Interval Time**

BMOD	BT Input Clock (frequency)	WDCNT Input Clock (frequency)	WDT Interval Time	Main Clock	Sub Clock
x000b	$f_{xx}/2^{12}$	$f_{xx}/(2^{12} \times 2^8)$	$2^{12} \times 2^8 \times 2^3/f_{xx}$	1.75–2 sec	224–256 sec
x011b	$f_{xx}/2^9$	$f_{xx}/(2^9 \times 2^8)$	$2^9 \times 2^8 \times 2^3/f_{xx}$	218.7–250 ms	28–32 sec
x101b	$f_{xx}/2^7$	$f_{xx}/(2^7 \times 2^8)$	$2^7 \times 2^8 \times 2^3/f_{xx}$	54.6–62.5 ms	7–8 sec
x111b	$f_{xx}/2^5$	$f_{xx}/(2^5 \times 2^8)$	$2^5 \times 2^8 \times 2^3/f_{xx}$	13.6–15.6 ms	1.75–2 sec

**NOTES:**

1. Clock frequencies assume a system oscillator clock frequency ( $f_{xx}$ ) of: 4.19 MHz Main clock or 32.768 kHz Sub clock
2.  $f_{xx}$  = system clock frequency.
3. If the WDMOD changes such as disable and enable, you must set WDTCF flag to “1” for starting WDCNT from zero state.

 **PROGRAMMING TIP — Using the Watchdog Timer**

```

RESET      DI
           BITS      EMB
           SMB      15
           LD       EA,#00H
           LD       SP,EA
           .
           .
           .
           LD       A,#0DH           ; WDCNT input clock is 7.82 ms
           LD       BMOD,A
           .
           .
           .
MAIN       BITS      WDTCF           ; Main routine operation period must be shorter than
                                           ; watchdog
                                           ; timer's period
           .
           .
           .
           JP       MAIN

```

www.DataSheet4U.com

## 8-BIT TIMER/COUNTER 0 (TC0)

### OVERVIEW

Timer/counter 0 (TC0) is used to count system 'events' by identifying the transition (high-to-low or low-to-high) of incoming square wave signals. To indicate that an event has occurred, or that a specified time interval has elapsed, TC0 generates an interrupt request. By counting signal transitions and comparing the current counter value with the reference register value, TC0 can be used to measure specific time intervals.

TC0 has a reloadable counter that consists of two parts: an 8-bit reference register (TREF0) into which you write the counter reference value, and an 8-bit counter register (TCNT0) whose value is automatically incremented by counter logic.

An 8-bit mode register, TMOD0, is used to activate the timer/counter and to select the basic clock frequency to be used for timer/counter operations. To dynamically modify the basic frequency, new values can be loaded into the TMOD0 register during program execution.

### TC0 FUNCTION SUMMARY

8-bit programmable timer	Generates interrupts at specific time intervals based on the selected clock frequency.
External event counter	Counts various system "events" based on edge detection of external clock signals at the TC0 input pin, TCL0. To start the event counting operation, TMOD0.2 is set to "1" and TMOD0.6 is cleared to "0".
Arbitrary frequency output	Outputs selectable clock frequencies to the TC0 output pin, TCLO0.
External signal divider	Divides the frequency of an incoming external clock signal according to a modifiable reference value (TREF0), and outputs the modified frequency to the TCLO0 pin.



**TC0 COMPONENT SUMMARY**

Mode register (TMOD0)	Activates the timer/counter and selects the internal clock frequency or the external clock source at the TCLO pin.
Reference register (TREF0)	Stores the reference value for the desired number of clock pulses between interrupt requests.
Counter register (TCNT0)	Counts internal or external clock pulses based on the bit settings in TMOD0 and TREF0.
Clock selector circuit	Together with the mode register (TMOD0), lets you select one of four internal clock frequencies or an external clock.
8-bit comparator	Determines when to generate an interrupt by comparing the current value of the counter register (TCNT0) with the reference value previously programmed into the reference register (TREF0).
Output latch (TOL0)	Where a clock pulse is stored pending output to the TC0 output pin, TCLO0.  When the contents of the TCNT0 and TREF0 registers coincide, the timer/counter interrupt request flag (IRQT0) is set to "1", the status of TOL0 is inverted, and an interrupt is generated.
Output enable flag (TOE0)	Must be set to logic one before the contents of the TOL0 latch can be output to TCLO0.
Interrupt request flag (IRQT0)	Cleared when TC0 operation starts and the TC0 interrupt service routine is executed and set to 1 whenever the counter value and reference value coincide.
Interrupt enable flag (IET0)	Must be set to logic one before the interrupt requests generated by timer/counter 0 can be processed.

Table 11-4. TC0 Register Overview

Register Name	Type	Description	Size	RAM Address	Addressing Mode	Reset Value
TMOD0	Control	Controls TC0 enable/disable (bit 2); clears and resumes counting operation (bit 3); sets input clock and clock frequency (bits 6–4)	8-bit	F90H–F91H	8-bit write-only; (TMOD0.3 is also 1-bit writeable)	"0"
TCNT0	Counter	Counts clock pulses matching the TMOD0 frequency setting	8-bit	F94H–F95H	8-bit read-only	"0"
TREF0	Reference	Stores reference value for the timer/counter 0 interval setting	8-bit	F96H–F97H	8-bit write-only	FFH
TOE0	Flag	Controls timer/counter 0 output to the TCLO0 pin	1-bit	F92H.2	1-bit write-only	"0"

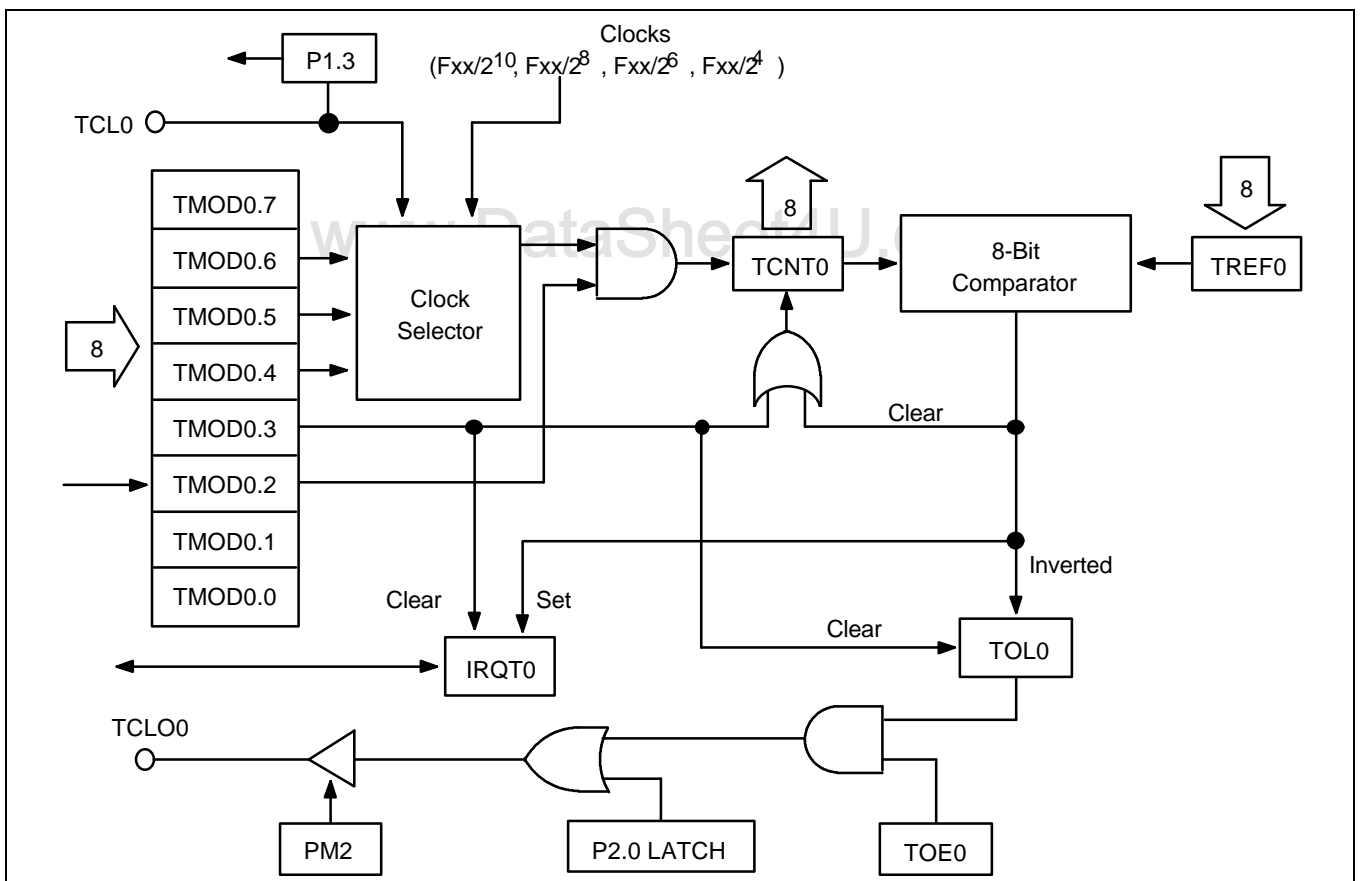

Figure 11-2. TC0 Circuit Diagram

**TC0 ENABLE/DISABLE PROCEDURE****Enable Timer/Counter 0**

- Set TMOD0.2 to logic one
- Set the TC0 interrupt enable flag IET0 to logic one
- Set TMOD0.3 to logic one

TCNT0, IRQT0, and TOL0 are cleared to logic zero, and timer/counter operation starts.

**Disable Timer/Counter 0**

- Set TMOD0.2 to logic zero

Clock signal input to the counter register TCNT0 is halted. The current TCNT0 value is retained and can be read if necessary.

www.DataSheet4U.com

### TC0 PROGRAMMABLE TIMER/COUNTER FUNCTION

Timer/counter 0 can be programmed to generate interrupt requests at various intervals based on the selected system clock frequency. Its 8-bit TC0 mode register TMOD0 is used to activate the timer/counter and to select the clock frequency.

The reference register TREF0 stores the value for the number of clock pulses to be generated between interrupt requests. The counter register, TCNT0, counts the incoming clock pulses, which are compared to the TREF0 value as TCNT0 is incremented. When there is a match ( $TREF0 = TCNT0$ ), an interrupt request is generated.

To program timer/counter 0 to generate interrupt requests at specific intervals, choose one of four internal clock frequencies (divisions of the system clock,  $f_{xx}$ ) and load a counter reference value into the TREF0 register. TCNT0 is incremented each time an internal counter pulse is detected with the reference clock frequency specified by TMOD0.4–TMOD0.6 settings.

To generate an interrupt request, the TC0 interrupt request flag (IRQT0) is set to logic one, the status of TOL0 is inverted, and the interrupt is generated. The content of TCNT0 is then cleared to 00H and TC0 continues counting. The interrupt request mechanism for TC0 includes an interrupt enable flag (IET0) and an interrupt request flag (IRQT0).

### TC0 OPERATION SEQUENCE

The general sequence of operations for using TC0 can be summarized as follows:

1. Set TMOD0.2 to "1" to enable TC0.
2. Set TMOD0.6 to "1" to enable the system clock ( $f_{xx}$ ) input.
3. Set TMOD0.5 and TMOD0.4 bits to desired internal frequency ( $f_{xx}/2^n$ ).
4. Load a value to TREF0 to specify the interval between interrupt requests.
5. Set the TC0 interrupt enable flag (IET0) to "1".
6. Set TMOD0.3 bit to "1" to clear TCNT0, IRQT0, and TOL0, and start counting.
7. TCNT0 increments with each internal clock pulse.
8. When the comparator shows  $TCNT0 = TREF0$ , the IRQT0 flag is set to "1" and an interrupt request is generated.
9. Output latch (TOL0) logic toggles high or low.
10. TCNT0 is cleared to 00H and counting resumes.
11. Programmable timer/counter operation continues until TMOD0.2 is cleared to "0".

**TC0 EVENT COUNTER FUNCTION**

Timer/counter 0 can monitor or detect system 'events' by using the external clock input at the TCL0 pin as the counter source. The TC0 mode register selects rising or falling edge detection for incoming clock signals. The counter register TCNT0 is incremented each time the selected state transition of the external clock signal occurs.

With the exception of the different TMOD0.4–TMOD0.6 settings, the operation sequence for TC0's event counter function is identical to its programmable timer/counter function. To activate the TC0 event counter function,

- Set TMOD0.2 to "1" to enable TC0;
- Clear TMOD0.6 to "0" to select the external clock source at the TCL0 pin;
- Select TCL0 edge detection for rising or falling signal edges by loading the appropriate values to TMOD0.5 and TMOD0.4.

**Table 11-5. TMOD0 Settings for TCL0 Edge Detection**

<b>TMOD0.5</b>	<b>TMOD0.4</b>	<b>TCL0 Edge Detection</b>
0	0	Rising edges
0	1	Falling edges

www.DataSheet4U.com

### TC0 CLOCK FREQUENCY OUTPUT

Using timer/counter 0, a modifiable clock frequency can be output to the TC0 clock output pin, TCLO0. To select the clock frequency, load the appropriate values to the TC0 mode register, TMOD0. The clock interval is selected by loading the desired reference value into the reference register TREF0. To enable the output to the TCLO0 pin, the following conditions must be met:

- TC0 output enable flag TOE0 must be set to "1"
- I/O mode flag for P2.0 must be set to output mode ("1")
- Output latch value for P2.0 must be set to "0"

In summary, the operational sequence required to output a TC0-generated clock signal to the TCLO0 pin is as follows:

1. Load a reference value to TREF0.
2. Set the internal clock frequency in TMOD0.
3. Initiate TC0 clock output to TCLO0 (TMOD0.2 = "1").
4. Set P2.0 mode flag to "1".
5. Set P2.0 output latch to "0".
6. Set TOE0 flag to "1".

Each time TCNT0 overflows and an interrupt request is generated, the state of the output latch TOL0 is inverted and the TC0-generated clock signal is output to the TCLO0 pin.

#### PROGRAMMING TIP — TC0 Signal Output to the TCLO0 Pin

Output a 30 ms pulse width signal to the TCLO0 pin:

```

BITS      EMB
SMB       15
LD        EA,#79H
LD        TREF0,EA
LD        EA,#4CH
LD        TMOD0,EA
LD        EA,#04H
LD        PMG2,EA      ; P2.0 ← output mode
BITR      P2.0         ; P2.0 clear
BITS      TOE0

```

### TC0 EXTERNAL INPUT SIGNAL DIVIDER

By selecting an external clock source and loading a reference value into the TC0 reference register, TREF0, you can divide the incoming clock signal by the TREF0 value and then output this modified clock frequency to the TCLO0 pin. The sequence of operations used to divide external clock input can be summarized as follows:

1. Load a signal divider value to the TREF0 register.
2. Clear TMOD0.6 to "0" to enable external clock input at the TCL0 pin.
3. Set TMOD0.5 and TMOD0.4 to desired TCL0 signal edge detection.
4. Set port 2.0 mode flag (PM2) to output ("1").
5. Set P2.0 output latch to "0".
6. Set TOE0 flag to "1" to enable output of the divided frequency to the TCLO0 pin

#### PROGRAMMING TIP — External TCL0 Clock Output to the TCLO0 Pin

Output external TCL0 clock pulse to the TCLO0 pin (divided by four):

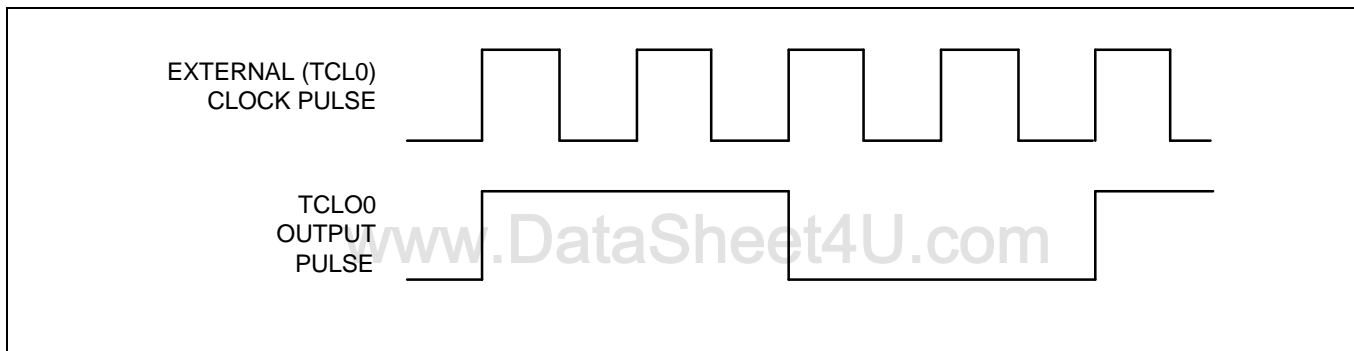

BITS	EMB	
SMB	15	
LD	EA,#01H	
LD	TREF0,EA	
LD	EA,#0CH	
LD	TMOD0,EA	
LD	EA,#04H	
LD	PMG2,EA	; P2.0 ← output mode
BITR	P2.0	; P2.0 clear
BITS	TOE0	

**TC0 MODE REGISTER (TMOD0)**

TMOD0 is the 8-bit mode control register for timer/counter 0. It is addressable by 8-bit write instructions. One bit, TMOD0.3, is also 1-bit writeable. RESET clears all TMOD0 bits to logic zero and disables TC0 operations.

F90H	TMOD0.3	TMOD0.2	"0"	"0"
F91H	"0"	TMOD0.6	TMOD0.5	TMOD0.4

TMOD0.2 is the enable/disable bit for timer/counter 0. When TMOD0.3 is set to "1", the contents of TCNT0, IRQT0, and TOL0 are cleared, counting starts from 00H, and TMOD0.3 is automatically reset to "0" for normal TC0 operation. When TC0 operation stops (TMOD0.2 = "0"), the contents of the TC0 counter register TCNT0 are retained until TC0 is re-enabled.

The TMOD0.6, TMOD0.5, and TMOD0.4 bit settings are used together to select the TC0 clock source. This selection involves two variables:

- Synchronization of timer/counter operations with either the rising edge or the falling edge of the clock signal input at the TCL0 pin, and
- Selection of one of four frequencies, based on division of the incoming system clock frequency, for use in internal TC0 operation.

**Table 11-6. TC0 Mode Register (TMOD0) Organization**

Bit Name	Setting	Resulting TC0 Function	Address
TMOD0.7	0	Always logic zero	F91H
TMOD0.6	0,1	Specify input clock edge and internal frequency	
TMOD0.5			
TMOD0.4			
TMOD0.3	1	Clear TCNT0, IRQT0, and TOL0 and resume counting immediately (This bit is automatically cleared to logic zero immediately after counting resumes.)	F90H
TMOD0.2	0	Disable timer/counter 0; retain TCNT0 contents	
	1	Enable timer/counter 0	
TMOD0.1	0	Always logic zero	
TMOD0.0	0	Always logic zero	



Table 11-7. TMOD0.6, TMOD0.5, and TMOD0.4 Bit Settings

TMOD0.6	TMOD0.5	TMOD0.4	Resulting Counter Source and Clock Frequency
0	0	0	External clock input (TCL0) on rising edges
0	0	1	External clock input (TCL0) on falling edges
1	0	0	$f_{xx}/2^{10}$ (4.09 kHz)
1	0	1	$f_{xx}/2^8$ (16.4 kHz)
1	1	0	$f_{xx}/2^6$ (65.5 kHz)
1	1	1	$f_{xx}/2^4$ (262 kHz)

**NOTE:** 'fxx' = selected system clock of 4.19 MHz.

### PROGRAMMING TIP — Restarting TC0 Counting Operation

1. Set TC0 timer interval to 4.09 kHz:

```

BITS      EMB
SMB       15
LD        EA,#4CH
LD        TMOD0,EA
EI
BITS      IET0

```

2. Clear TCNT0, IRQT0, and TOL0 and restart TC0 counting operation:

```

BITS      EMB
SMB       15
BITS      TMOD0.3

```

### TC0 COUNTER REGISTER (TCNT0)

The 8-bit counter register for timer/counter 0, TCNT0, is read-only and can be addressed by 8-bit RAM control instructions. RESET sets all TCNT0 register values to logic zero (00H).

Whenever TMOD0.3 is enabled, TCNT0 is cleared to logic zero and counting resumes. The TCNT0 register value is incremented each time an incoming clock signal is detected that matches the signal edge and frequency setting of the TMOD0 register (specifically, TMOD0.6, TMOD0.5, and TMOD0.4).

Each time TCNT0 is incremented, the new value is compared to the reference value stored in the TC0 reference buffer, TREF0. When  $TCNT0 = TREF0$ , an overflow occurs in the TCNT0 register, the interrupt request flag, IRQT0, is set to logic one, and an interrupt request is generated to indicate that the specified timer/counter interval has elapsed.

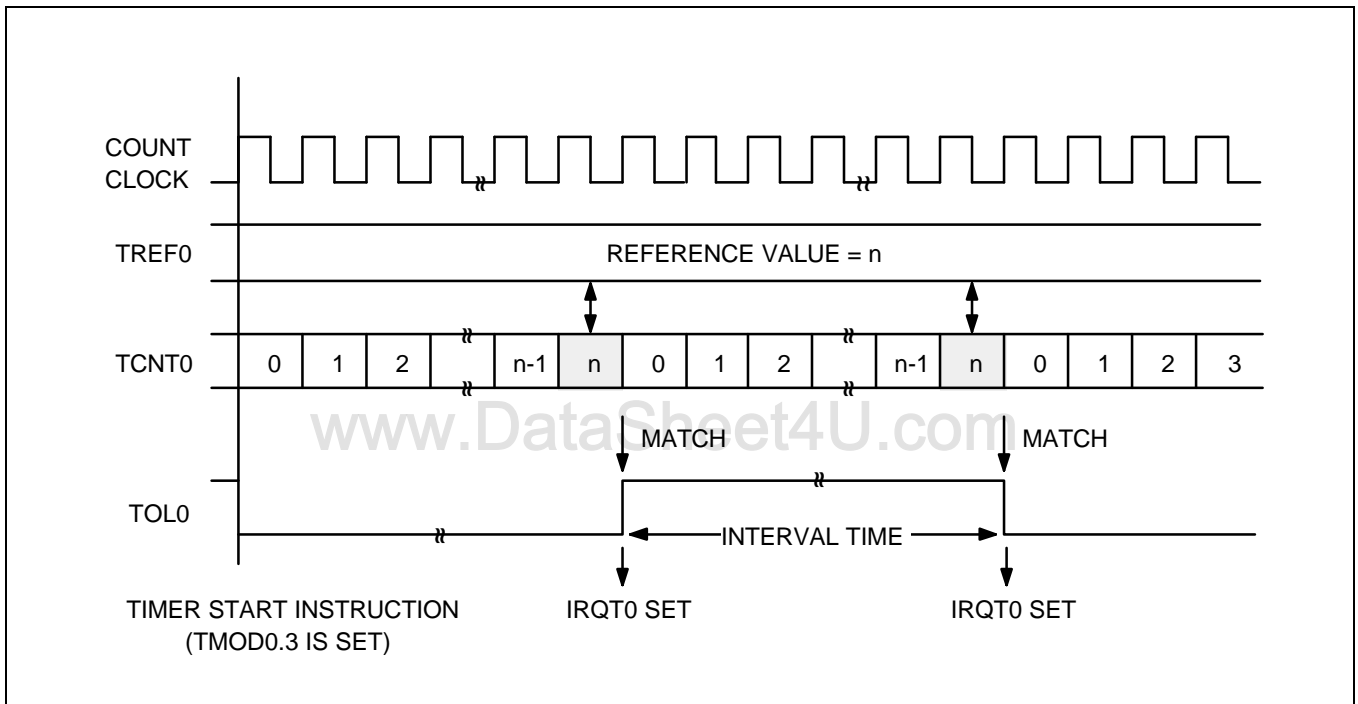

Figure 11-3. TC0 Timing Diagram

### TC0 REFERENCE REGISTER (TREF0)

The TC0 reference register TREF0 is an 8-bit write-only register. It is addressable by 8-bit RAM control instructions. RESET initializes the TREF0 value to 'FFH'.

TREF0 is used to store a reference value to be compared to the incrementing TCNT0 register in order to identify an elapsed time interval. Reference values will differ depending upon the specific function that TC0 is being used to perform — as a programmable timer/counter, event counter, clock signal divider, or arbitrary frequency output source.

During timer/counter operation, the value loaded into the reference register is compared to the TCNT0 value. When TCNT0 = TREF0, the TC0 output latch (TOL0) is inverted and an interrupt request is generated to signal the interval or event. The TREF0 value, together with the TMOD0 clock frequency selection, determines the specific TC0 timer interval. Use the following formula to calculate the correct value to load to the TREF0 reference register:

$$\text{TC0 timer interval} = (\text{TREF0 value} + 1) \times \frac{1}{\text{TMOD0 frequency setting}}$$

(TREF0 value ≠ 0)

### TC0 OUTPUT ENABLE FLAG (TOE0)

The 1-bit timer/counter 0 output enable flag TOE0 controls output from timer/counter 0 to the TCLO0 pin. TOE0 is addressable by 1-bit write instructions.

	(MSB)		(LSB)
F92H	"u"	<b>TOE0</b>	"u"

**NOTE:** "u" means that the value is undetermined.

When you set the TOE0 flag to "1", the contents of TOL0 can be output to the TCLO0 pin. Whenever a RESET occurs, TOE0 is automatically set to logic zero, disabling all TC0 output.

### TC0 OUTPUT LATCH (TOL0)

TOL0 is the output latch for timer/counter 0. When the 8-bit comparator detects a correspondence between the value of the counter register TCNT0 and the reference value stored in the TREF0 register, the TOL0 value is inverted — the latch toggles high-to-low or low-to-high. Whenever the state of TOL0 is switched, the TC0 signal is output. TC0 output may be directed to the TCLO0 pin.

Assuming TC0 is enabled, when bit 3 of the TMOD0 register is set to "1", the TOL0 latch is cleared to logic zero, along with the counter register TCNT0 and the interrupt request flag, IRQT0, and counting resumes immediately. When TC0 is disabled (TMOD0.2 = "0"), the contents of the TOL0 latch are retained and can be read, if necessary.

### PROGRAMMING TIP — Setting a TC0 Timer Interval

To set a 30 ms timer interval for TC0, given  $f_{xx} = 4.19$  MHz, follow these steps.

1. Select the timer/counter 0 mode register with a maximum setup time of 62.5 ms (assume the TC0 counter clock =  $f_{xx}/2^{10}$ , and TREF0 is set to FFH):
2. Calculate the TREF0 value:

$$30 \text{ ms} = \frac{\text{TREF0 value} + 1}{4.09 \text{ kHz}}$$

$$\text{TREF0} + 1 = \frac{30 \text{ ms}}{244 \mu\text{s}} = 122.9 = 7AH$$

$$\text{TREF0 value} = 7AH - 1 = 79H$$

3. Load the value 79H to the TREF0 register:

BITS	EMB
SMB	15
LD	EA,#79H
LD	TREF0,EA
LD	EA,#4CH
LD	TMOD0,EA

www.DataSheet4U.com

## WATCH TIMER

### OVERVIEW

The watch timer is a multi-purpose timer which consists of three basic components:

- 8-bit watch timer mode register (WMOD)
- Clock selector
- Frequency divider circuit

Watch timer functions include real-time and watch-time measurement and interval timing for the main and subsystem clock. It is also used as a clock source for the LCD controller and for generating buzzer (BUZ) output.

### Real-Time and Watch-Time Measurement

To start watch timer operation, set bit 2 of the watch timer mode register (WMOD.2) to logic one. The watch timer starts, the interrupt request flag IRQW is automatically set to logic one, and interrupt requests commence in 0.5-second intervals.

Since the watch timer functions as a quasi-interrupt instead of a vectored interrupt, the IRQW flag should be cleared to logic zero by program software as soon as a requested interrupt service routine has been executed.

### Using a System or Subsystem Clock Source

The watch timer can generate interrupts based on the system clock frequency or on the subsystem clock. When the zero bit of the WMOD register is set to "1", the watch timer uses the subsystem clock signal (fxt) as its source; if WMOD.0 = "0", the system clock (fxx) is used as the signal source, according to the following formula:

$$\text{Watch timer clock (fw)} = \frac{\text{System clock (fxx)}}{128} = 32.768 \text{ kHz (fxx = 4.19 MHz)}$$

This feature is useful for controlling timer-related operations during stop mode. When stop mode is engaged, the main system clock (fx) is halted, but the subsystem clock continues to oscillate. By using the subsystem clock as the oscillation source during stop mode, the watch timer can set the interrupt request flag IRQW to "1", thereby releasing stop mode.

### Clock Source Generation for LCD Controller

The watch timer supplies the clock frequency for the LCD controller ( $f_{\text{LCD}}$ ). Therefore, if the watch timer is disabled, the LCD controller does not operate.

### Buzzer Output Frequency Generator

The watch timer can generate a steady 2 kHz, 4 kHz, 8 kHz, or 16 kHz signal to the BUZ pin. To select the desired BUZ frequency, load the appropriate value to the WMOD register. This output can then be used to actuate an external buzzer sound. To generate a BUZ signal, three conditions must be met:

- The WMOD.7 register bit is set to "1"
- The output latch for I/O port 2.3 is cleared to "0"
- The port 2.3 output mode flag (PM2) set to 'output' mode

### Timing Tests in High-Speed Mode

By setting WMOD.1 to "1", the watch timer will function in high-speed mode, generating an interrupt every 3.91 ms. At its normal speed (WMOD.1 = '0'), the watch timer generates an interrupt request every 0.5 seconds. High-speed mode is useful for timing events for program debugging sequences.

### Check Subsystem Clock Level Feature

The watch timer can also check the input level of the subsystem clock by testing WMOD.3. If WMOD.3 is "1", the input level at the XT<sub>in</sub> pin is high; if WMOD.3 is "0", the input level at the XT<sub>in</sub> pin is low.

www.DataSheet4U.com

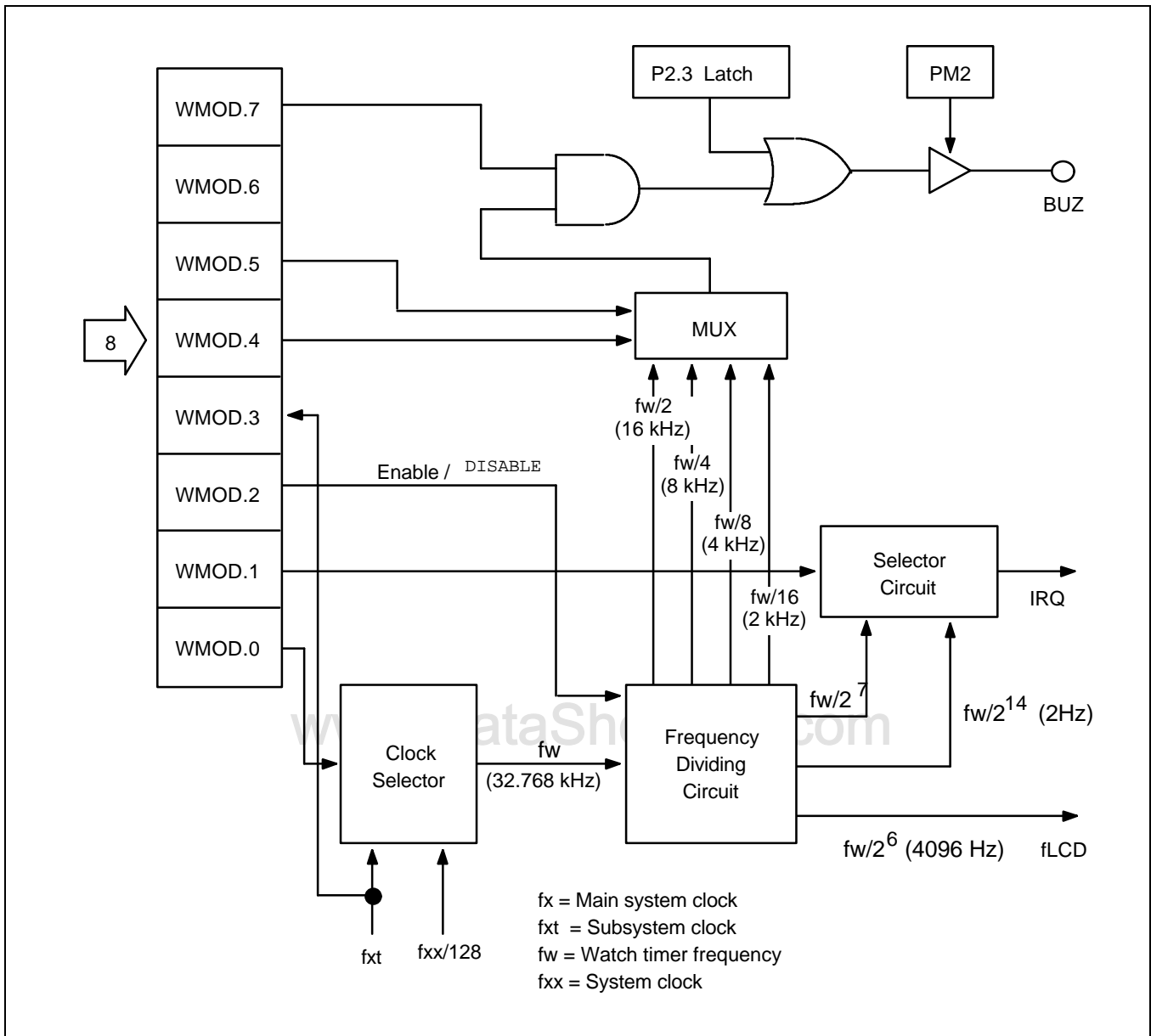

Figure 11-4. Watch Timer Circuit Diagram

**WATCH TIMER MODE REGISTER (WMOD)**

The watch timer mode register WMOD is used to select specific watch timer operations. It is 8-bit write-only addressable. An exception is WMOD bit 3 (the XT<sub>in</sub> input level control bit) which is 1-bit read-only addressable. A RESET automatically sets WMOD.3 to the current input level of the subsystem clock, XT<sub>in</sub> (high, if logic one; low, if logic zero), and all other WMOD bits to logic zero.

F88H	WMOD.3	WMOD.2	WMOD.1	WMOD.0
F89H	WMOD.7	"0"	WMOD.5	WMOD.4

In summary, WMOD settings control the following watch timer functions:

- Watch timer clock selection (WMOD.0)
- Watch timer speed control (WMOD.1)
- Enable/disable watch timer (WMOD.2)
- XT<sub>in</sub> input level control (WMOD.3)
- Buzzer frequency selection (WMOD.4 and WMOD.5)
- Enable/disable buzzer output (WMOD.7)

**Table 11-8. Watch Timer Mode Register (WMOD) Organization**

Bit Name	Values		Function	Address
WMOD.7	0		Disable buzzer (BUZ) signal output	F89H
	1		Enable buzzer (BUZ) signal output	
WMOD.6	0		Always logic zero	F88H
WMOD.5–.4	0	0	2 kHz buzzer (BUZ) signal output	
	0	1	4 kHz buzzer (BUZ) signal output	
	1	0	8 kHz buzzer (BUZ) signal output	
	1	1	16 kHz buzzer (BUZ) signal output	
WMOD.3	0		Input level to XT <sub>in</sub> pin is low	F88H
	1		Input level to XT <sub>in</sub> pin is high	
WMOD.2	0		Disable watch timer; clear frequency dividing circuits	F88H
	1		Enable watch timer	
WMOD.1	0		Normal mode; sets IRQW to 0.5 seconds	F88H
	1		High-speed mode; sets IRQW to 3.91 ms	
WMOD.0	0		Select f <sub>xx</sub> /128 as the watch timer clock (fw)	F88H
	1		Select subsystem clock as watch timer clock (fw)	

**NOTE:** System clock frequency (f<sub>xx</sub>) is assumed to be 4.19 MHz; subsystem clock (f<sub>xt</sub>) is assumed to be 32.768 kHz.



### PROGRAMMING TIP — Using the Watch Timer

1. Select a subsystem clock as the LCD display clock, a 0.5 second interrupt, and 2 kHz buzzer enable:

```

BITS      EMB
SMB       15
LD        EA,#04H
LD        PMG2,EA      ; P2.3 ← output mode
BITR      P2.3
LD        EA,#85H
LD        WMOD,EA
BITS      IEW

```

2. Sample real-time clock processing method:

```

CLOCK     BTSTZ      IRQW      ; 0.5 second check
          RET        ; No, return
          •         ; Yes, 0.5 second interrupt generation
          •
          •         ; Increment HOUR, MINUTE, SECOND

```

www.DataSheet4U.com

# 12 LCD CONTROLLER/DRIVER

## OVERVIEW

The KS57C2302/C2304 microcontroller can directly drive an up-to-128-dot (32 segments x 4 commons) LCD panel. Its LCD block has the following components:

- LCD controller/driver
- Display RAM for storing display data
- 32 segment output pins (SEG0–SEG31)
- 4 common output pins (COM0–COM3)
- Four LCD operating power supply pins ( $V_{LC0}$ – $V_{LC2}$ )

The frame frequency, duty and bias, and the segment pins used for display output, are determined by bit settings in the LCD mode register, LMOD.

The LCD control register, LCON, is used to turn the LCD display on and off, to switch current to the dividing resistors for the LCD display, and to output LCD clock (LCDCK) and synchronizing signal (LCDSY) for LCD display expansion. Data written to the LCD display RAM can be transferred to the segment signal pins automatically without program control.

When a subsystem clock is selected as the LCD clock source, the LCD display is enabled even during main clock stop and idle modes.

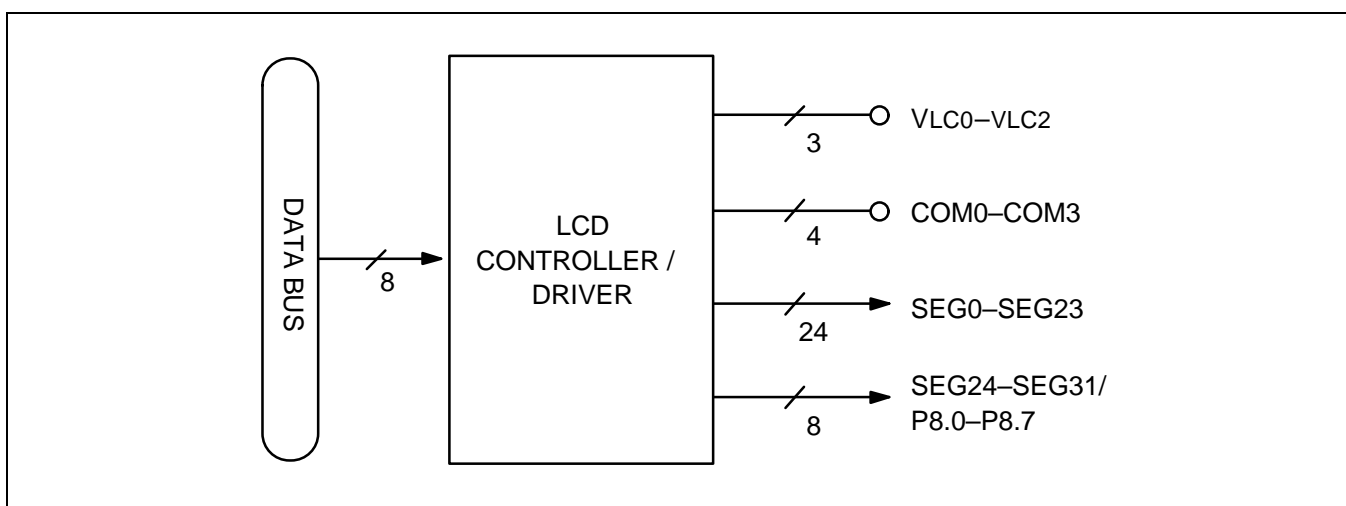

Figure 12-1. LCD Function Diagram

LCD CIRCUIT DIAGRAM

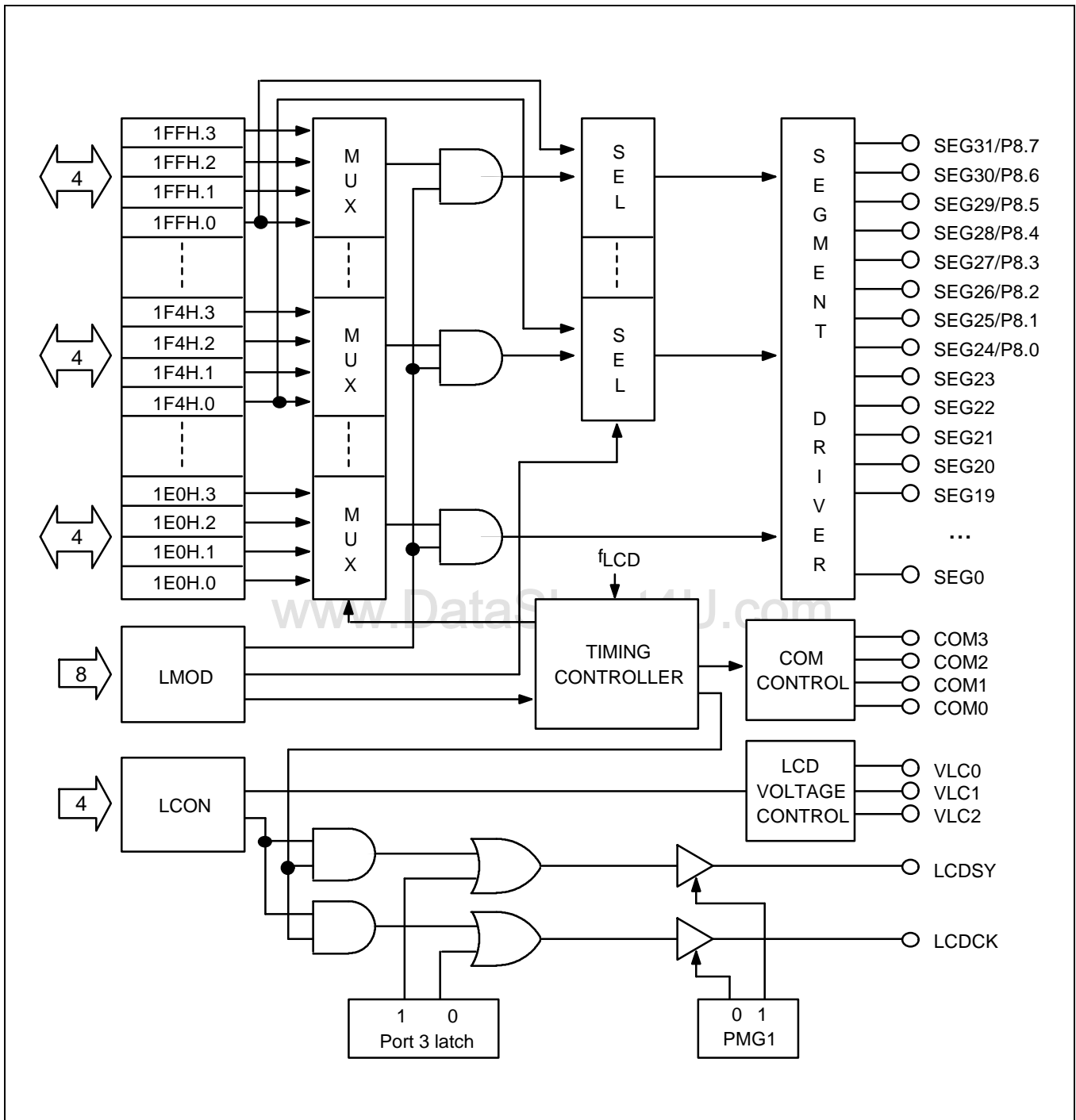

Figure 12-2. LCD Circuit Diagram

## LCD RAM ADDRESS AREA

RAM addresses of bank 1 are used as LCD data memory. These locations can be addressed by 1-bit, 4-bit instructions. When the bit value of a display segment is "1", the LCD display is turned on; when the bit value is "0", the display is turned off.

Display RAM data are sent out through segment pins SEG0–SEG31 using a direct memory access (DMA) method that is synchronized with the  $f_{LCD}$  signal. RAM addresses in this location that are not used for LCD display can be allocated to general-purpose use.

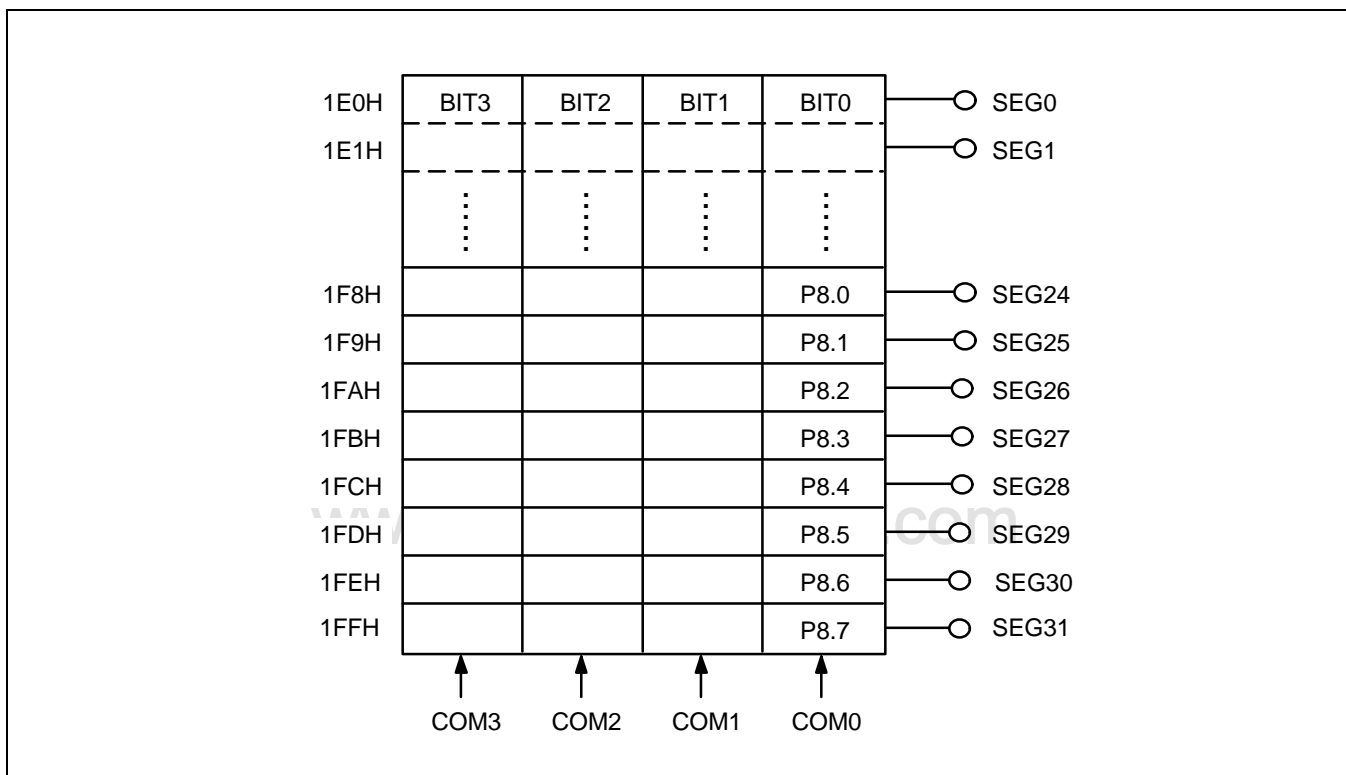

Figure 12-3. LCD Display Data RAM Organization

Table 12-1. Common Signal Pins Used per Duty Cycle

Display Mode	COM0 Pin	COM1 Pin	COM2 Pin	COM3 Pin
Static	Selected	N/C	N/C	N/C
1/2	Selected	Selected	N/C	N/C
1/3	Selected	Selected	Selected	N/C
1/4	Selected	Selected	Selected	Selected

**NOTE:** NC = no connection is required.

**LCD CONTROL REGISTER (LCON)**

The LCD control register (LCON) is used to turn the LCD display on and off, to output LCD clock (LCDCK) and synchronizing signal (LCDSY) for LCD display expansion, and to control the flow of current to dividing resistors in the LCD circuit. Following a RESET, all LCON values are cleared to "0". This turns the LCD display off and stops the flow of current to the dividing resistors.

F8EH    "0"    LCON.2    "0"    LCON.0    LCON

The effect of the LCON.0 setting is dependent upon the current setting of bits LMOD.3.

**Table 12-2. LCD Control Register (LCON) Organization**

LCON Bit	Setting	Description
LCON.3	0	This bit is used for internal testing only; always logic zero.
LCON.2	0	Disable LCDCK and LCDSY signal outputs.
	1	Enable LCDCK and LCDSY signal outputs.
LCON.1	0	Always logic zero.
LCON.0	0	LCD output low, display off; cut off current to dividing resistor, and output port 8 latch contents.
	1	If LMOD.3 = "0": LCD display off; output port 8 latch contents. If LMOD.3 = "1": COM and SEG output in display mode; LCD display on.

**NOTE:** The LCON.3 register must be set to "0".

**Table 12-3. LCON.0 and LMOD.3 Bit Settings**

LCON.0	LMOD.3	COM0–COM3	SEG0–SEG31	P8.0–P8.7	
0	–	Output low; LCD display off	Output low; LCD display off	Output latch contents	Cut off current to dividing resistors
1	0	LCD display off	LCD display off	Output latch contents	LCD display off
	1	COM output corresponds to display mode	SEG output corresponds to display mode	Output latch contents	LCD display on

**LCD MODE REGISTER (LMOD)**

The LCD mode control register LMOD is used to control display mode; LCD clock, segment or port output, and display on/off. LMOD can be manipulated using 8-bit write instructions, bit 3 (LMOD.3) can be also written by 1-bit instructions.

F8CH	LMOD.3	LMOD.2	LMOD.1	LMOD.0
F8DH	LMOD.7	LMOD.6	LMOD.5	LMOD.4

The LCD clock signal, LCDCK, determines the frequency of COM signal scanning of each segment output. This is also referred to as the 'frame frequency'. Since LCDCK is generated by dividing the watch timer clock (fw), the watch timer must be enabled when the LCD display is turned on. RESET clears the LMOD register values to logic zero.

The LCD display can continue to operate during idle and stop modes if a subsystem clock is used as the watch timer source. The LCD mode register LMOD controls the output mode of the 8 pins used for normal outputs (P8.0–P8.7). Bits LMOD.7–.6 define the segment output and normal bit output configuration.

**Table 12-4. LCD Mode Register (LMOD) Organization**

LMOD.7	LMOD.6	LCD Output Segments and 1-Bit Output Pins
0	0	Segments 24–27, and 28–31
0	1	Segments 24–27; 1-bit output at P8.4–P8.7
1	0	Segments 28–31; 1-bit output at P8.0–P8.3
1	1	1-bit output only at P8.0–P8.3 and P8.4–P8.7

LMOD.5	LMOD.4	LCD Clock (LCDCK) Frequency
0	0	$fw/2^9 = 64 \text{ Hz}$
0	1	$fw/2^8 = 128 \text{ Hz}$
1	0	$fw/2^7 = 256 \text{ Hz}$
1	1	$fw/2^6 = 512 \text{ Hz}$

LMOD.3	LMOD.2	LMOD.1	LMOD.0	Duty and Bias Selection for LCD Display
0	–	–	–	LCD Display off
1	0	0	0	1/4 duty, 1/3 bias
1	0	0	1	1/3 duty, 1/3 bias
1	0	1	0	1/2 duty, 1/2 bias
1	0	1	1	1/3 duty, 1/2 bias
1	1	0	0	Static

**NOTE:** fw = 32.768 kHz, watch timer clock

Table 12-5. LCD Clock Signal (LCDCK), Frame Frequency and LCD sync Signal (LCDSY)

LCDCK Frequency	Static	1/2 Duty	1/3 Duty	1/4 Duty
$fw/2^9 = 64$ Hz	64 (16)	32 (16)	21 (21)	16 (16)
$fw/2^8 = 128$ Hz	128 (32)	64 (32)	43 (43)	32 (32)
$fw/2^7 = 256$ Hz	256 (64)	128 (64)	85 (85)	64 (64)
$fw/2^6 = 512$ Hz	512 (128)	256 (128)	171 (171)	128 (128)

**NOTES:**

1.  $fw = 32.768$  kHz
2. The number in parentheses is a frequency for LCDSY.

**LCD DRIVE VOLTAGE**

LCD Power Supply	Static Mode	1/2 Bias	1/3 Bias
$V_{LC0}$	$V_{LCD}$	$V_{LCD}$	$V_{LCD}$
$V_{LC1}$	$2/3 V_{LCD}$	$1/2 V_{LCD}$	$2/3 V_{LCD}$
$V_{LC2}$	$1/3 V_{LCD}$	$1/2 V_{LCD}$	$1/3 V_{LCD}$
$V_{LC3}$	0 V	0 V	0 V

**NOTE:** The LCD panel display may deteriorate if a DC voltage is applied that lies between the common and segment signal voltage. Therefore, always drive the LCD panel with AC voltage.

**LCD VOLTAGE DIVIDING RESISTORS**

On-chip voltage dividing resistors for the LCD drive power supply can be configured by internal voltage dividing resistors. Using these internal voltage dividing resistors, you can drive either a 3-volt or a 5-volt LCD display using external bias. Bias pins are connected externally to the  $V_{LCD}$  pin so that it can handle the different LCD drive voltages. To cut off the current supply to the voltage dividing resistors, clear LCON.0 when you turn the LCD display off.

**COMMON (COM) SIGNALS**

The common signal output pin selection (COM pin selection) varies according to the selected duty cycle.

- In 1/2 duty mode, COM0–COM1 pins are selected
- In 1/3 duty mode, COM0–COM2 pins are selected
- In 1/4 duty mode, COM0–COM3 pins are selected

**SEGMENT (SEG) SIGNALS**

The 32 LCD segment signal pins are connected to corresponding display RAM locations at bank 1. Bits of the display RAM are synchronized with the common signal output pins.

When the bit value of a display RAM location is "1", a select signal is sent to the corresponding segment pin. When the display bit is "0", a 'no-select' signal is sent to the corresponding segment pin.

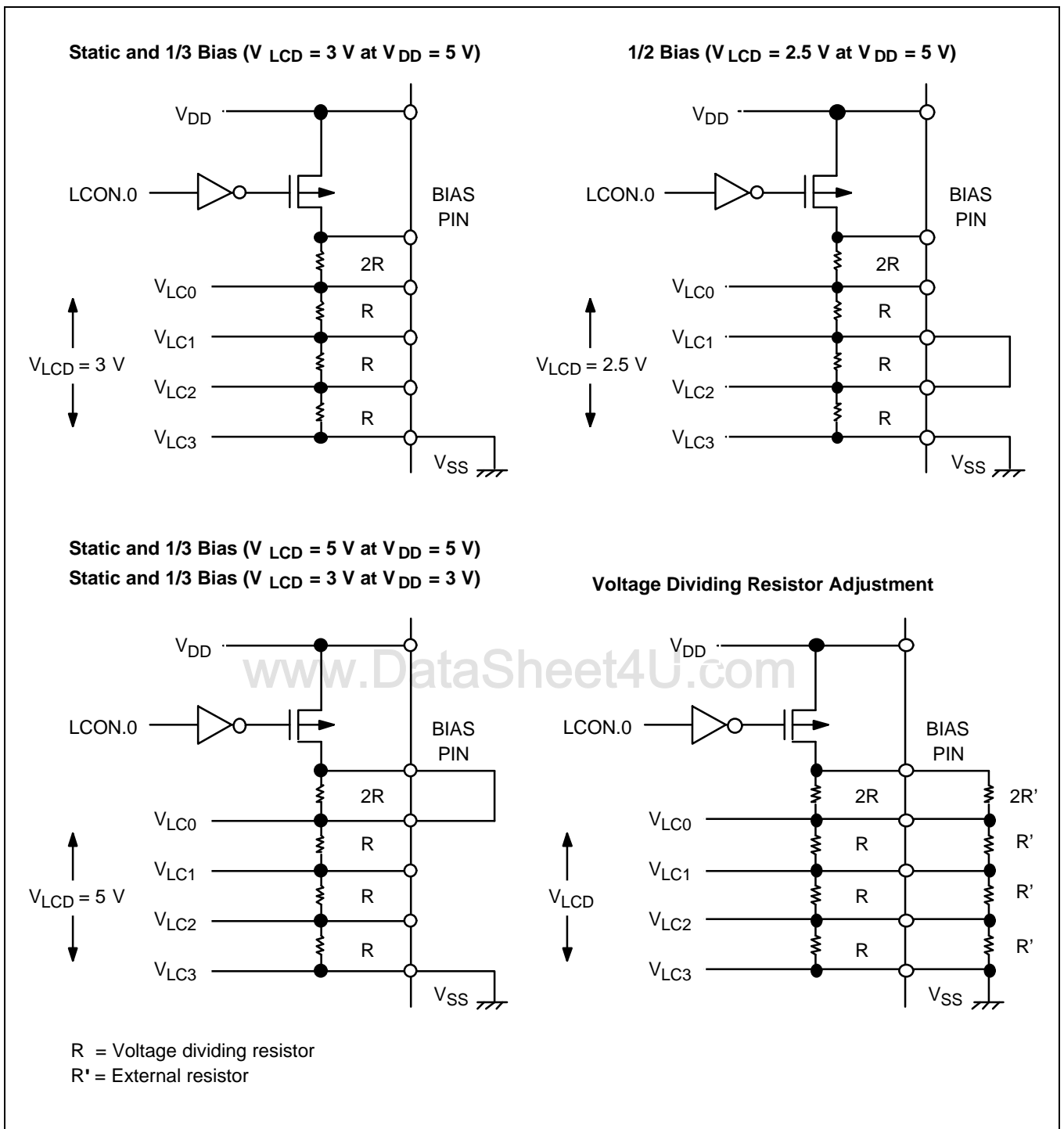

Figure 12-4. Voltage Dividing Resistor Circuit Diagrams



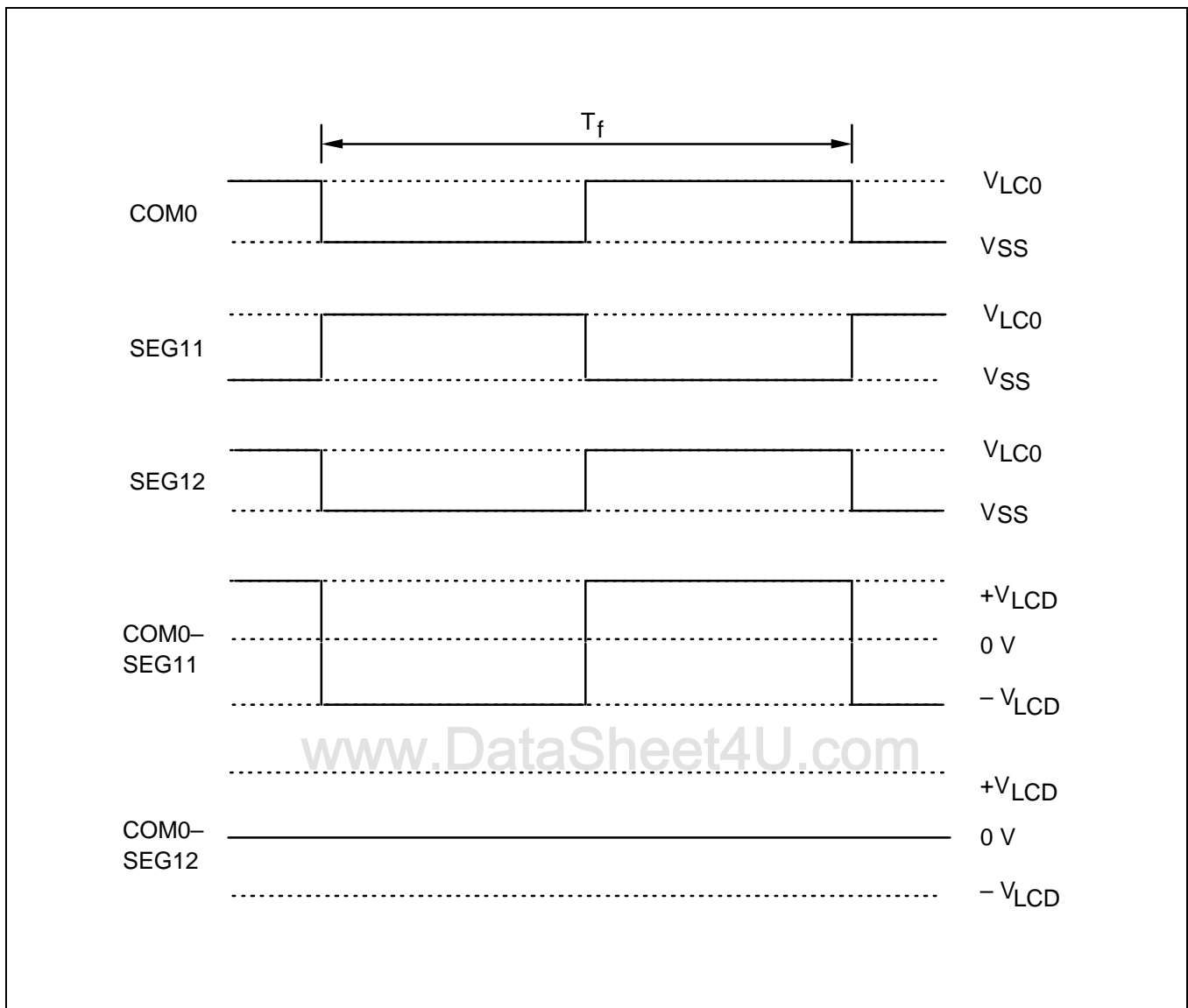

Figure 12-5. LCD Signal Waveforms in Static Mode

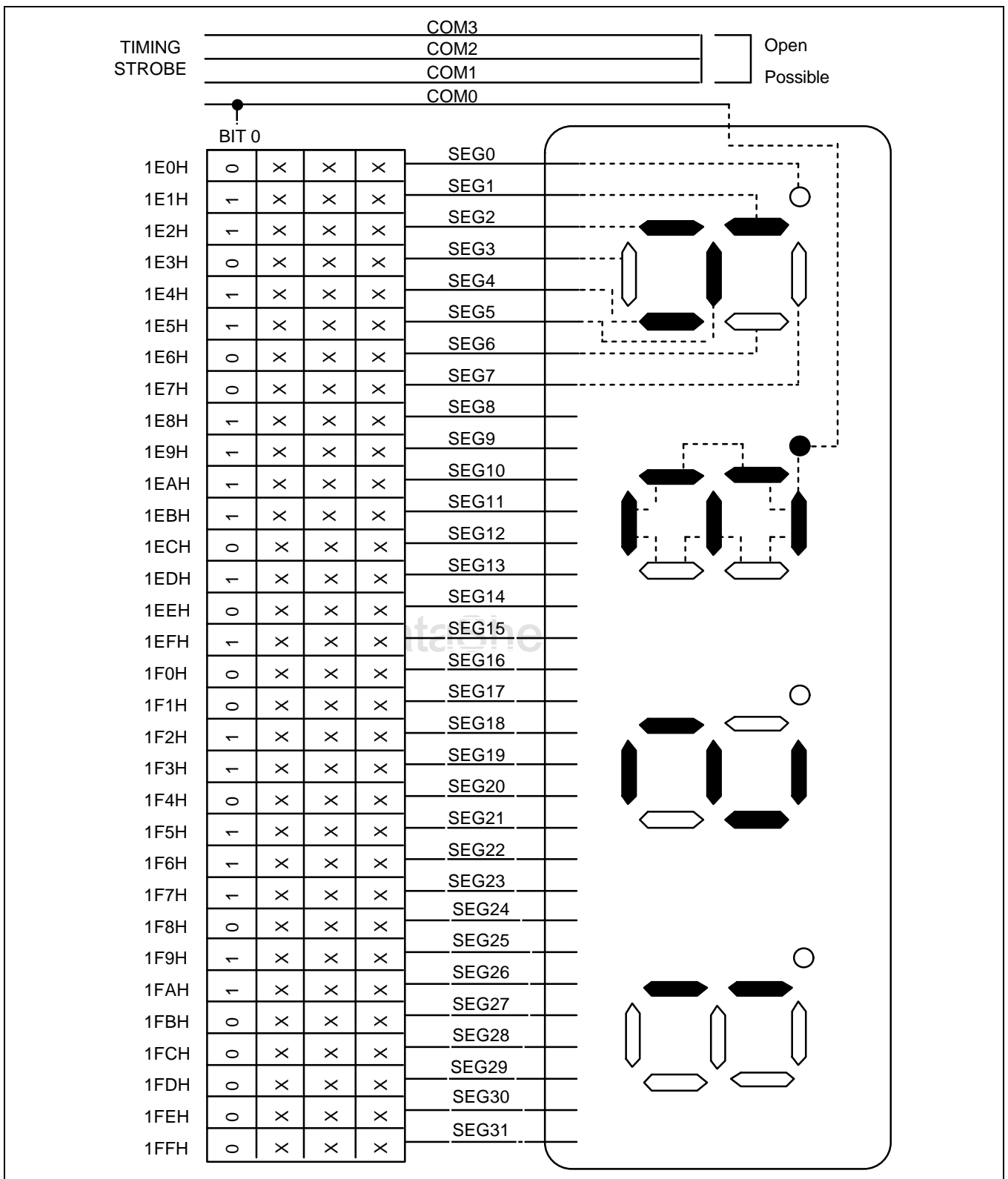

Figure 12-6. LCD Connection Example in Static Mode

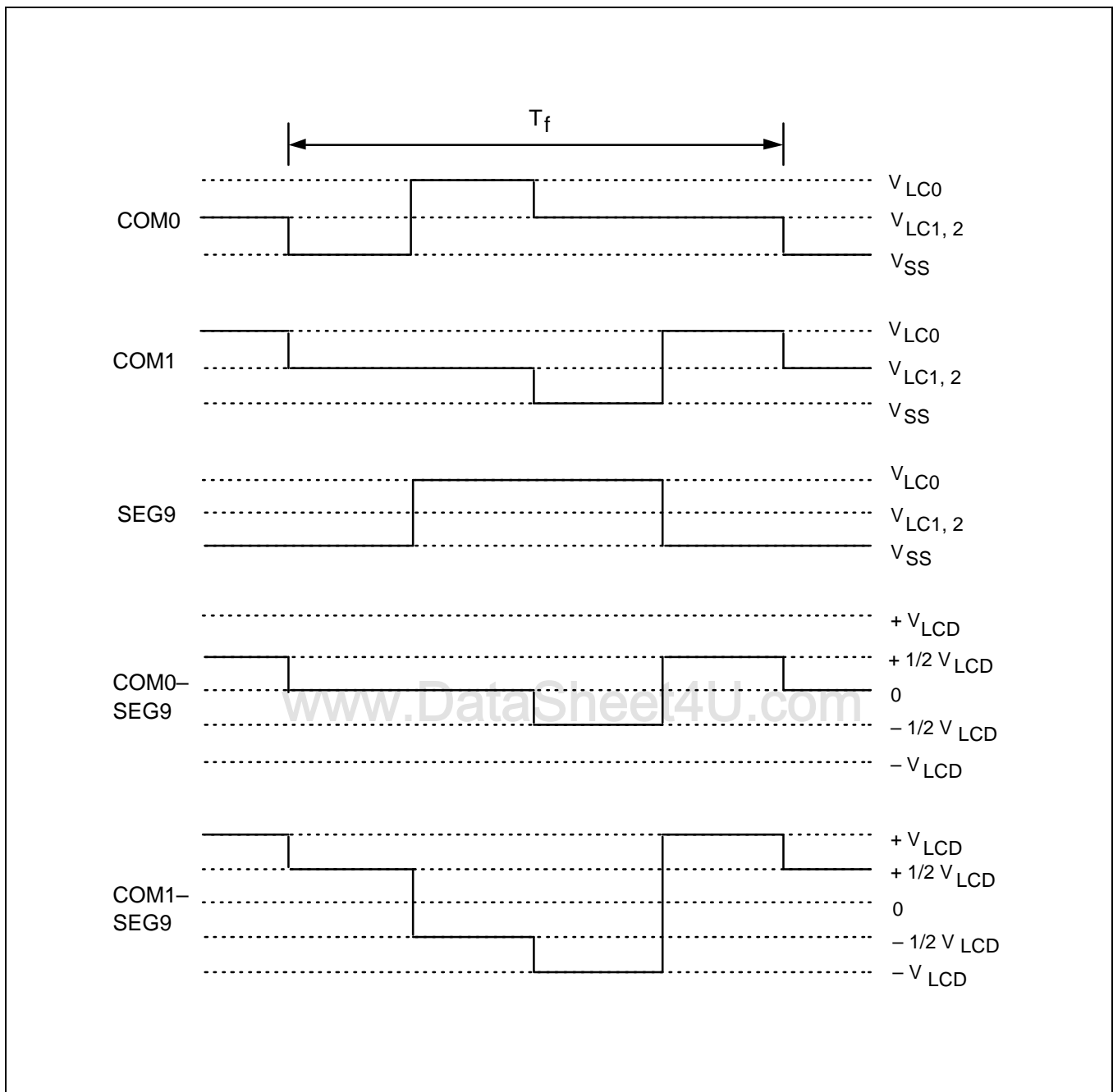

Figure 12-7. LCD Signal Waveforms at 1/2 Duty, 1/2 Bias

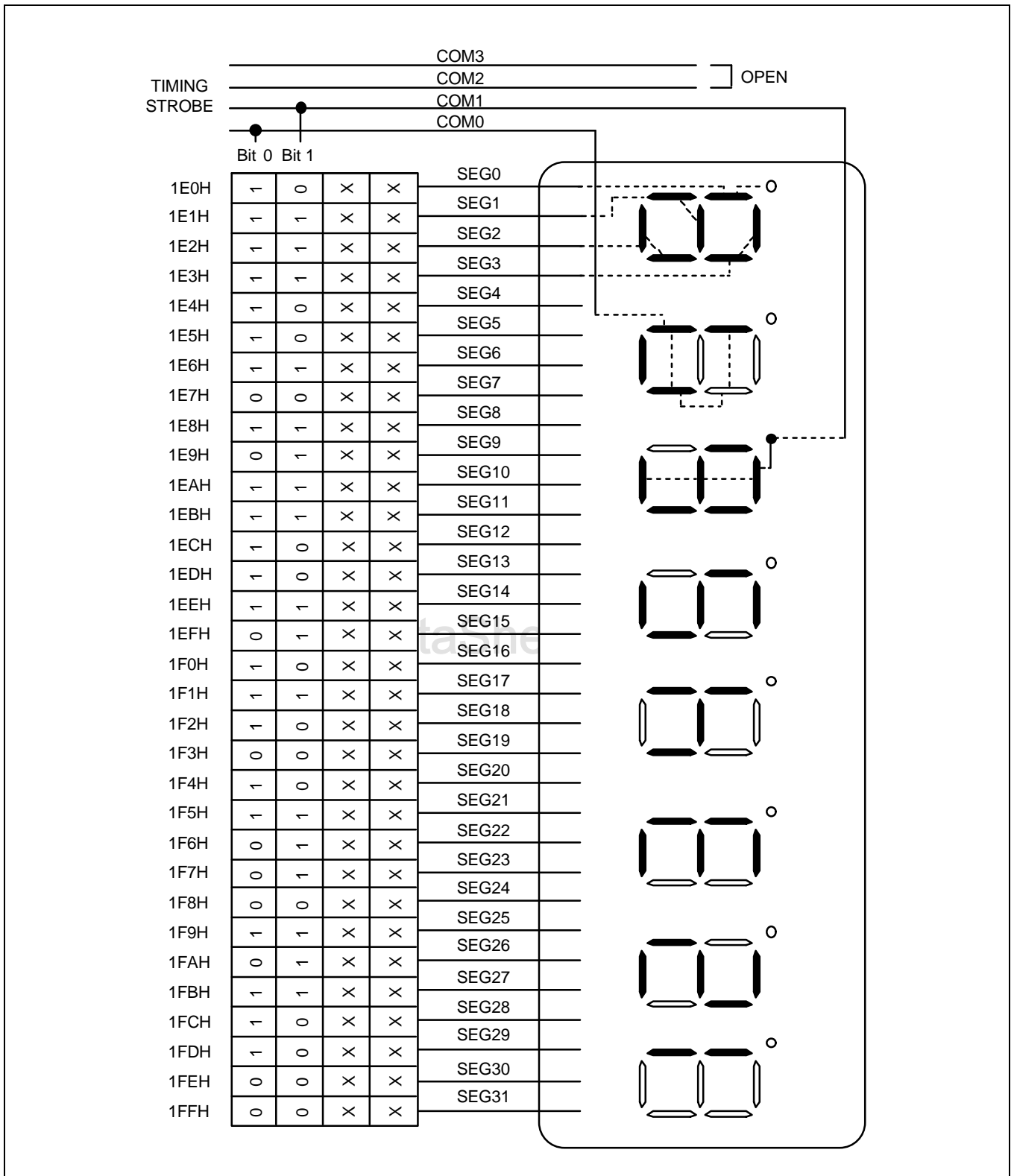

Figure 12-8. LCD Connection Example at 1/2 Duty, 1/2 Bias

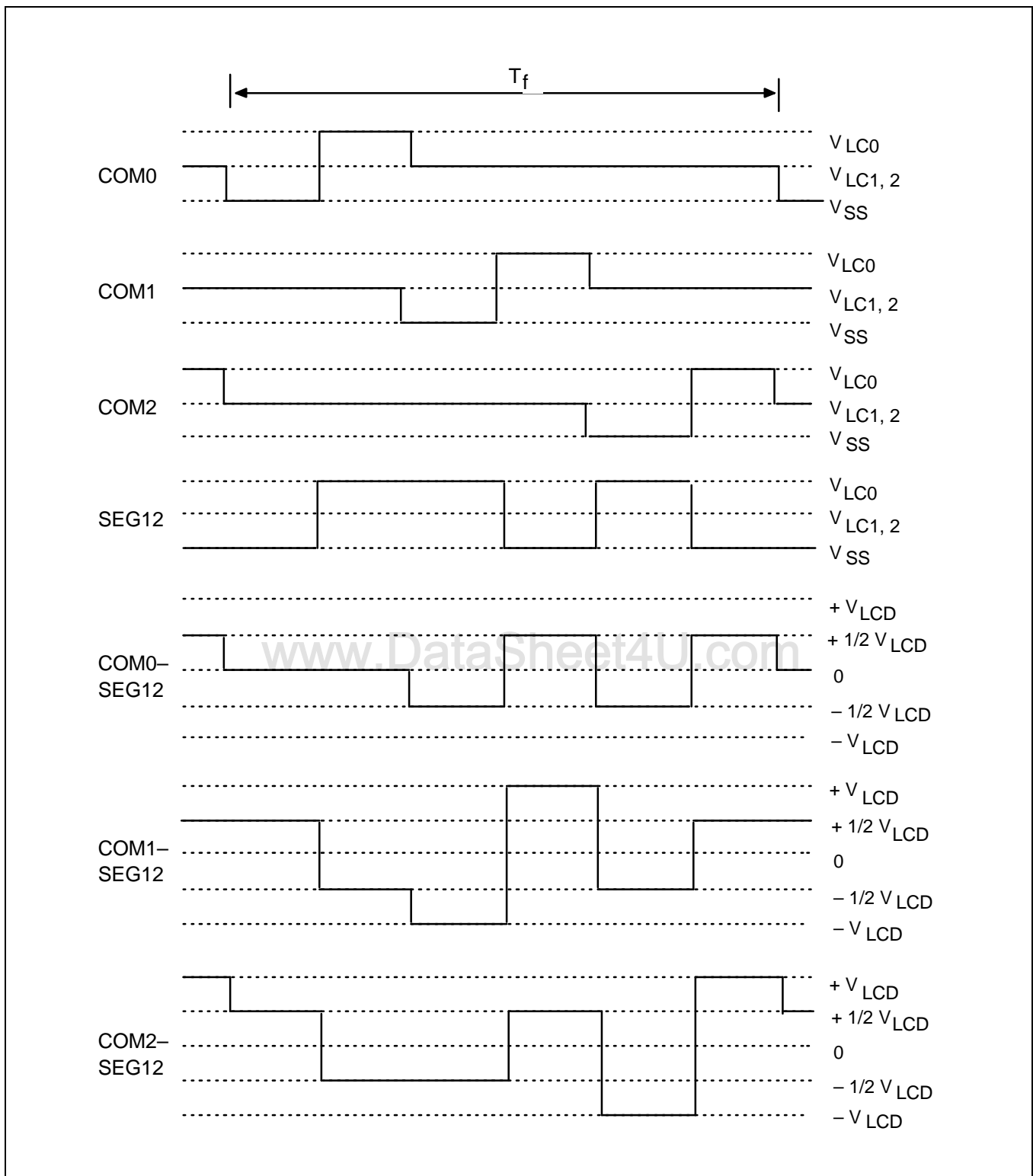

Figure 12-9. LCD Signal Waveforms at 1/3 Duty, 1/2 Bias

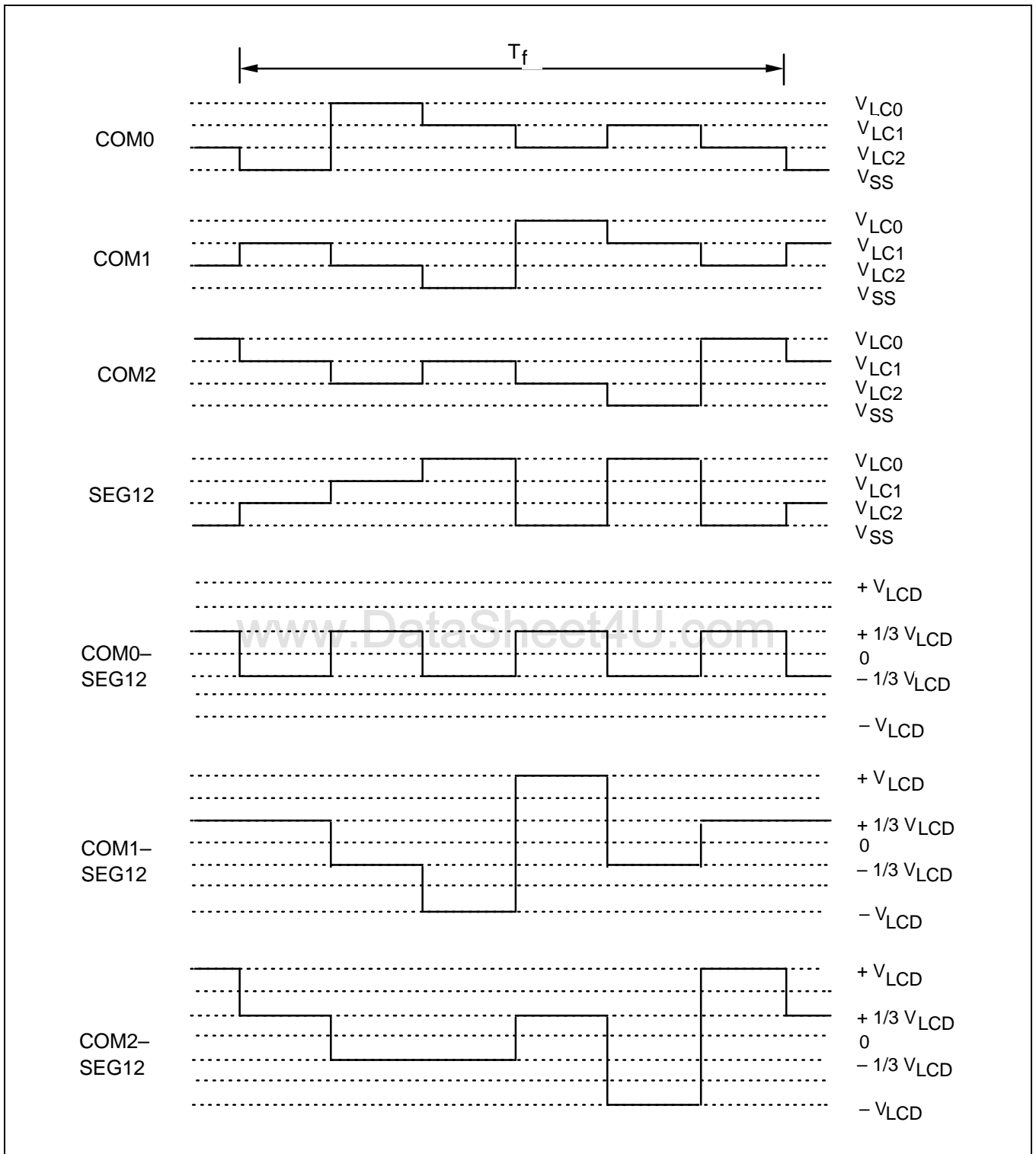

Figure 12-10. LCD Signal Waveforms at 1/3 Duty, 1/3 Bias

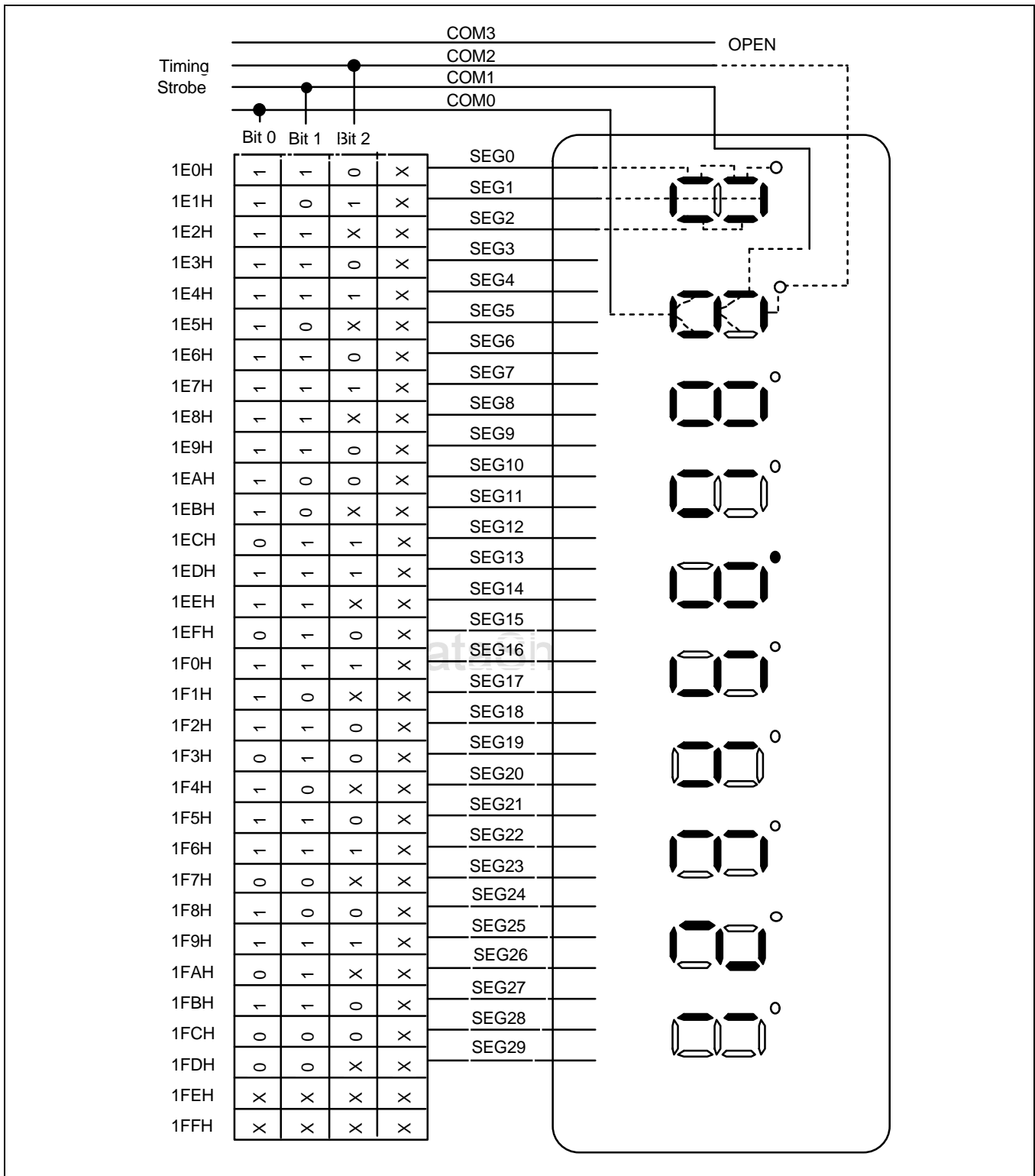

Figure 12-11. LCD Connection Example at 1/3 Duty, 1/3 Bias

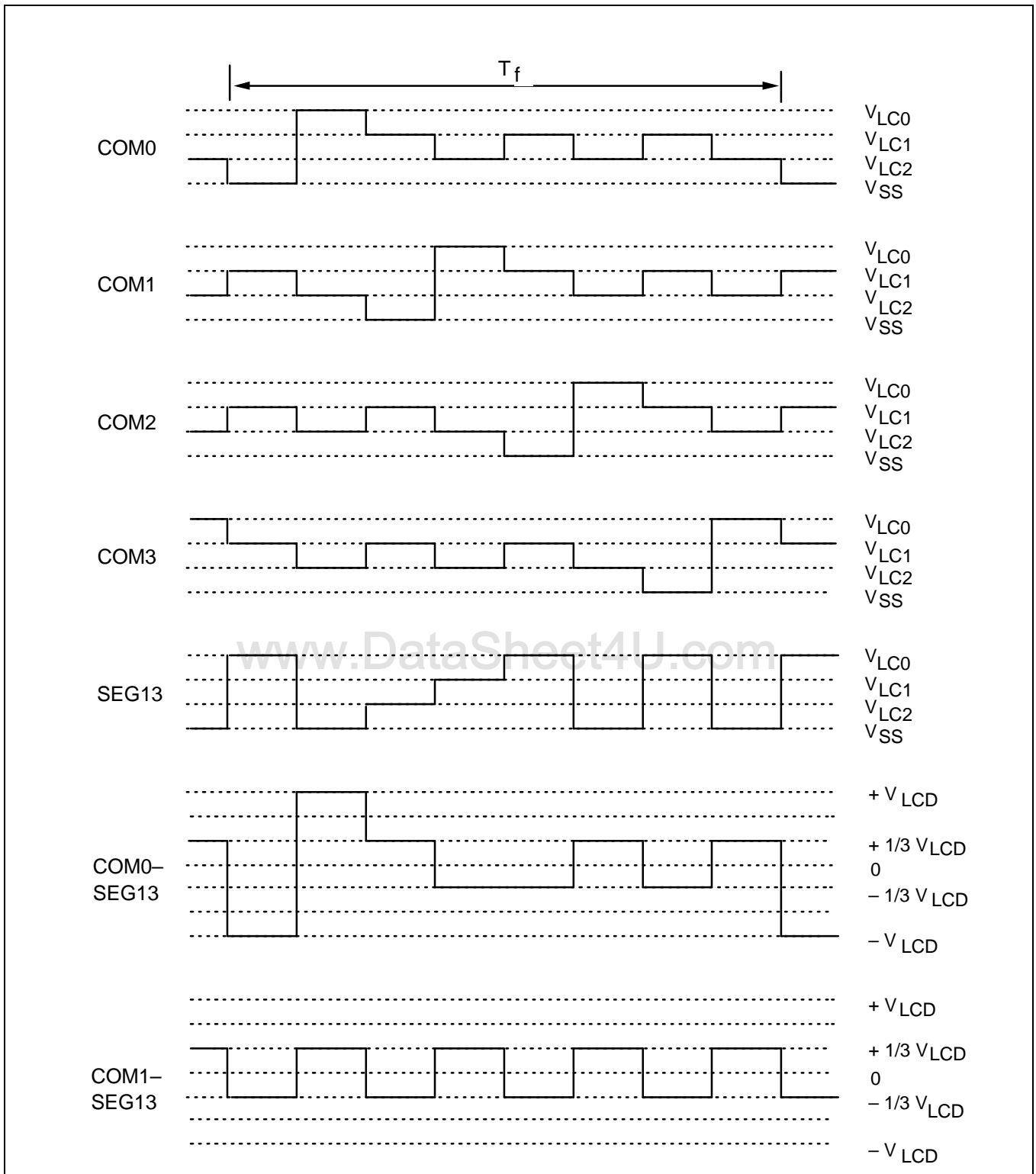

Figure 12-12. LCD Signal Waveforms at 1/4 Duty, 1/3 Bias



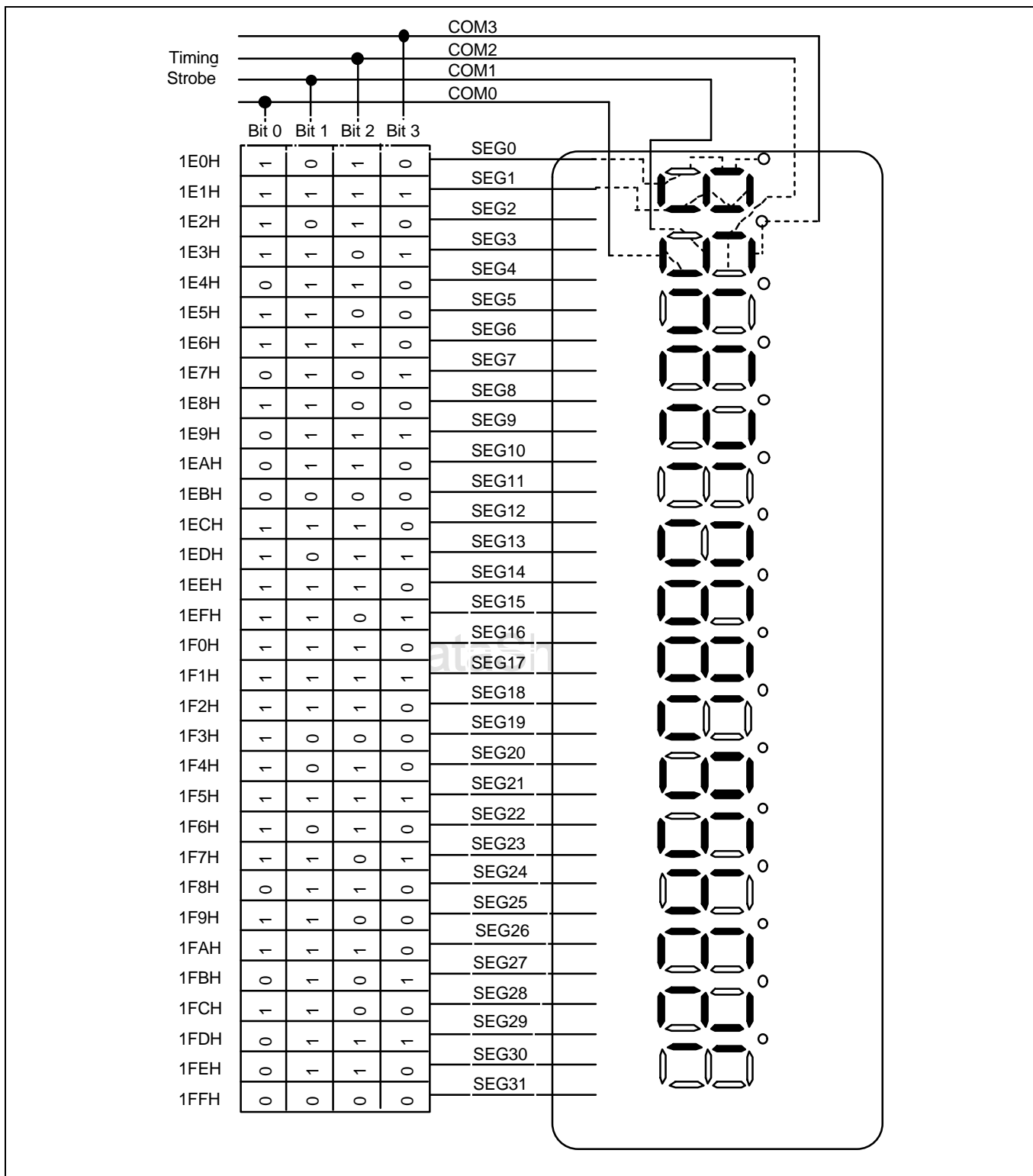

Figure 12-13. LCD Connection Example at 1/4 Duty, 1/3 Bias

# 13

## ELECTRICAL DATA

### OVERVIEW

In this section, information on KS57C2302/C2304 electrical characteristics is presented as tables and graphics. The information is arranged in the following order:

#### Standard Electrical Characteristics

- Absolute maximum ratings
- D.C. electrical characteristics
- Main system clock oscillator characteristics
- Subsystem clock oscillator characteristics
- I/O capacitance
- A.C. electrical characteristics
- Operating voltage range

#### Miscellaneous Timing Waveforms

- A.C timing measurement point
- Clock timing measurement at  $X_{IN}$
- Clock timing measurement at  $XT_{IN}$
- TCL0 timing
- Input timing for  $RESET$
- Input timing for external interrupts

#### Stop Mode Characteristics and Timing Waveforms

- RAM data retention supply voltage in stop mode
- Stop mode release timing when initiated by  $RESET$
- Stop mode release timing when initiated by an interrupt request

Table 13-1. Absolute Maximum Ratings

 $(T_A = 25\text{ }^\circ\text{C})$ 

Parameter	Symbol	Conditions	Rating	Units
Supply Voltage	$V_{DD}$	–	– 0.3 to + 6.5	V
Input Voltage	$V_{IH}$	All I/O ports	– 0.3 to $V_{DD} + 0.3$	
Output Voltage	$V_O$		– 0.3 to $V_{DD} + 0.3$	
Output Current High	$I_{OH}$	One I/O port active	– 15	mA
		All I/O ports active	– 30	
Output Current Low	$I_{OL}$	One I/O port active	+ 30 (Peak value)	
			+ 15 (note)	
		Total value for ports 2 and 3	+ 60 (Peak value)	
			+ 20 (note)	
Total value for port 6	+ 50			
	+ 20 (note)			
Operating Temperature	$T_A$	–	– 40 to + 85	$^\circ\text{C}$
Storage Temperature	$T_{stg}$	–	– 65 to + 150	

**NOTE:** The values for Output Current Low ( $I_{OL}$ ) are calculated as Peak Value  $\times \sqrt{\text{Duty}}$ .

www.DataSheet4U.com

Table 13-2. D.C. Electrical Characteristics

 $(T_A = -40\text{ }^\circ\text{C}$  to  $+85\text{ }^\circ\text{C}$ ,  $V_{DD} = 1.8\text{ V}$  to  $5.5\text{ V}$ )

Parameter	Symbol	Conditions	Min	Typ	Max	Units
Input high voltage	$V_{IH1}$	All input pins except those specified below for $V_{IH2}$ , $V_{IH3}$	$0.7 V_{DD}$	–	$V_{DD}$	V
	$V_{IH2}$	Ports 1, 6, and RESET	$0.8 V_{DD}$	–	$V_{DD}$	
	$V_{IH3}$	$X_{IN}$ , $X_{OUT}$ , and $XT_{IN}$	$V_{DD} - 0.1$	–	$V_{DD}$	
Input low voltage	$V_{IL1}$	Ports 2 and 3	–	–	$0.3 V_{DD}$	V
	$V_{IL2}$	Ports 1, 6 and RESET	–	–	$0.2 V_{DD}$	
	$V_{IL3}$	$X_{IN}$ , $X_{OUT}$ , and $XT_{IN}$	–	–	0.1	
Output high voltage	$V_{OH1}$	$V_{DD} = 4.5\text{ V}$ to $5.5\text{ V}$ $I_{OH} = -1\text{ mA}$ Ports 2, 3, 6 and BIAS	$V_{DD} - 1.0$	–	–	V
	$V_{OH2}$	$V_{DD} = 4.5\text{ V}$ to $5.5\text{ V}$ $I_{OH} = -100\text{ }\mu\text{A}$ Port 8 only	$V_{DD} - 2.0$	–	–	

Table 13-2. D.C. Electrical Characteristics (Continued)

(T<sub>A</sub> = -40 °C to +85 °C, V<sub>DD</sub> = 1.8 V to 5.5 V)

Parameter	Symbol	Conditions	Min	Typ	Max	Units
Output low voltage	V <sub>OL1</sub>	V <sub>DD</sub> = 4.5 V to 5.5 V I <sub>OL</sub> = 15 mA, Ports 2, 3, 6	-	0.4	2	V
	V <sub>OL2</sub>	V <sub>DD</sub> = 4.5 V to 5.5 V I <sub>OL</sub> = 100 μA; Port 8 only	-	-	1	
Input high leakage current	I <sub>LIH1</sub>	V <sub>IN</sub> = V <sub>DD</sub> All input pins except those specified below for I <sub>LIH2</sub>	-	-	3	μA
	I <sub>LIH2</sub>	V <sub>IN</sub> = V <sub>DD</sub> X <sub>IN</sub> , X <sub>OUT</sub> and XT <sub>IN</sub>	-	-	20	
Input low leakage current	I <sub>LIL1</sub>	V <sub>IN</sub> = 0 V All input pins except X <sub>IN</sub> , X <sub>OUT</sub> , and XT <sub>IN</sub>	-	-	-3	
	I <sub>LIL2</sub>	V <sub>IN</sub> = 0 V X <sub>IN</sub> , X <sub>OUT</sub> , and XT <sub>IN</sub>	-	-	-20	
Output high leakage current	I <sub>LOH1</sub>	V <sub>OUT</sub> = V <sub>DD</sub> All output pins	-	-	3	μA
Output low leakage current	I <sub>LOL</sub>	V <sub>OUT</sub> = 0 V All output pins	-	-	-3	
Pull-up resistor	R <sub>L1</sub>	V <sub>IN</sub> = 0 V; V <sub>DD</sub> = 5 V Ports 1, 2, 3, 6	25	50	100	KΩ
		V <sub>DD</sub> = 3 V	50	100	200	
	R <sub>L2</sub>	V <sub>IN</sub> = 0 V; V <sub>DD</sub> = 5 V RESET	100	250	400	
		V <sub>DD</sub> = 3 V	200	500	800	
LCD voltage dividing resistor	R <sub>LCD</sub>	T <sub>A</sub> = 25 °C	100	150	200	
COM output impedance	R <sub>COM</sub>	V <sub>DD</sub> = 5 V	-	3	6	
		V <sub>DD</sub> = 3 V		5	15	
SEG output impedance	R <sub>SEG</sub>	V <sub>DD</sub> = 5 V	-	3	6	
		V <sub>DD</sub> = 3 V		5	15	
COM output voltage deviation	V <sub>DC</sub>	V <sub>DD</sub> = 5 V (V <sub>LC0</sub> -COMi) I <sub>o</sub> = ± 15μA (i= 0-3)	-	± 45	± 90	mV

Table 13-2. D.C. Electrical Characteristics (Continued)

(T<sub>A</sub> = -40 °C to +85 °C, V<sub>DD</sub> = 1.8 V to 5.5 V)

Parameter	Symbol	Conditions	Min	Typ	Max	Units
SEG output voltage deviation	V <sub>DS</sub>	V <sub>DD</sub> = 5 V (VLC0-SEGi) I <sub>o</sub> = ± 15μA (i= 0-31)	-	ñ 45	ñ 90	mV
VLC0 Output voltage	VLC0	T <sub>A</sub> = 25 °C	0.6V <sub>DD</sub> - 0.2	0.6V <sub>DD</sub>	0.6V <sub>DD</sub> + 0.2	V
VLC1 Output voltage	VLC1	T <sub>A</sub> = 25 °C	0.4V <sub>DD</sub> - 0.2	0.4V <sub>DD</sub>	0.4V <sub>DD</sub> + 0.2	
VLC2 Output voltage	VLC2	T <sub>A</sub> = 25 °C	0.2V <sub>DD</sub> - 0.2	0.2V <sub>DD</sub>	0.2V <sub>DD</sub> + 0.2	

www.DataSheet4U.com

Table 13-2. D.C. Electrical Characteristics (Concluded)

(T<sub>A</sub> = -40 °C to +85 °C, V<sub>DD</sub> = 1.8 V to 5.5 V)

Parameter	Symbol	Conditions	Min	Typ	Max	Units		
Supply Current (1)	I <sub>DD1</sub> (2)	Main operating: V <sub>DD</sub> = 5 V ± 10% CPU = fx/4 SCMOD = 0000B Crystal oscillator C1 = C2 = 22 pF	6.0 MHz 4.19 MHz	-	3.5 2.5	8 5.5	mA	
		V <sub>DD</sub> = 3 V ± 10%	6.0 MHz 4.19 MHz		1.6 1.2	4 3		
	I <sub>DD2</sub> (2)	Main idle mode; V <sub>DD</sub> = 5 V ± 10% CPU = fx/4 SCMOD = 0000B Crystal oscillator C1 = C2 = 22 pF	6.0 MHz 4.19 MHz	-	1 0.9	2.5 2		
		V <sub>DD</sub> = 3 V ± 10%	6.0 MHz 4.19 MHz		0.5 0.4	1.0 0.8		
	I <sub>DD3</sub>	Sub operating: V <sub>DD</sub> = 3 V ± 10% CPU = fxt/4, SCMOD = 1001B 32 kHz crystal oscillator		-	15	30		μA
	I <sub>DD4</sub>	Sub idle mode: V <sub>DD</sub> = 3 V ± 10% CPU = fxt/4, SCMOD = 1001B 32 kHz crystal oscillator		-	6	15		
I <sub>DD5</sub>	Stop mode: V <sub>DD</sub> = 5V ± 10% CPU=fxt/4, SCMOD = 1101B							
I <sub>DD6</sub> (3)	Stop mode: V <sub>DD</sub> = 5 V ± 10% CPU = fx/4, SCMOD = 0100B		-	0.5	3			

**NOTES:**

- D.C. electrical values for supply current (I<sub>DD1</sub> to I<sub>DD6</sub>) do not include current drawn through internal pull-up resistors and through LCD voltage dividing resistors.
- Data includes the power consumption for sub-system clock oscillation.
- When the system clock mode register, SCMOD, is set to 0100B, the sub-system clock oscillation stops. The main-system clock oscillation stops by the STOP instruction.

Table 13-3. Main System Clock Oscillator Characteristics

(T<sub>A</sub> = -40 °C + 85 °C, V<sub>DD</sub> = 1.8 V to 5.5 V)

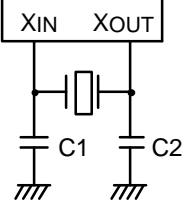
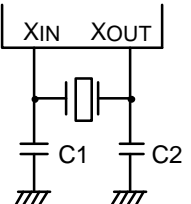
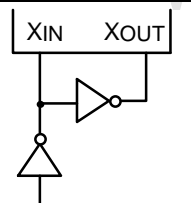
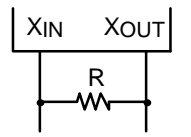
Oscillator	Clock Configuration	Parameter	Test Condition	Min	Typ	Max	Units
Ceramic Oscillator		Oscillation frequency (1)	–	0.4	–	6.0	MHz
		Stabilization time (2)	Stabilization occurs when V <sub>DD</sub> is equal to the minimum oscillator voltage range.	–	–	4	ms
Crystal Oscillator		Oscillation frequency (1)	–	0.4	–	6.0	MHz
		Stabilization time (2)	V <sub>DD</sub> = 4.5 V to 5.5 V	–	–	10	ms
			V <sub>DD</sub> = 1.8 V to 4.5 V	–	–	30	
External Clock		X <sub>IN</sub> input frequency (1)	–	0.4	–	6.0	MHz
		X <sub>IN</sub> input high and low level width (t <sub>XH</sub> , t <sub>XL</sub> )	–	83.3	–	–	ns
RC Oscillator		Frequency (1)	V <sub>DD</sub> = 5 V R = 20 KΩ, V <sub>DD</sub> = 5 V R = 39 KΩ, V <sub>DD</sub> = 3 V	0.4	– 2.0 1.0	2	MHz

**NOTES:**

- Oscillation frequency and X<sub>IN</sub> input frequency data are for oscillator characteristics only.
- Stabilization time is the interval required for oscillator stabilization after a power-on occurs, or when stop mode is terminated.

Table 13-4. Subsystem Clock Oscillator Characteristics

(T<sub>A</sub> = -40 °C + 85 °C, V<sub>DD</sub> = 1.8 V to 5.5 V)

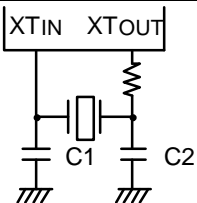
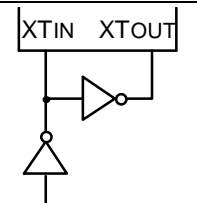
Oscillator	Clock Configuration	Parameter	Test Condition	Min	Typ	Max	Units
Crystal Oscillator		Oscillation frequency (1)	–	32	32.768	35	kHz
		Stabilization time (2)	V <sub>DD</sub> = 4.5 V to 5.5 V	–	1.0	2	s
			V <sub>DD</sub> = 1.8 V to 4.5 V	–	–	10	
External Clock		XT <sub>IN</sub> input frequency (1)	–	32	–	100	KHz
		XT <sub>IN</sub> input high and low level width (t <sub>XTL</sub> , t <sub>XTH</sub> )	–	5	–	15	μs

**NOTES:**

- Oscillation frequency and XT<sub>IN</sub> input frequency data are for oscillator characteristics only.
- Stabilization time is the interval required for oscillator stabilization after a power-on occurs.

Table 13-5. Input/Output Capacitance

(T<sub>A</sub> = 25 °C, V<sub>DD</sub> = 0 V)

Parameter	Symbol	Condition	Min	Typ	Max	Units
Input capacitance	C <sub>IN</sub>	f = 1 MHz; Unmeasured pins are returned to V <sub>SS</sub>	–	–	15	pF
Output capacitance	C <sub>OUT</sub>		–	–	15	pF
I/O capacitance	C <sub>IO</sub>		–	–	15	pF



Table 13-6. A.C. Electrical Characteristics

(T<sub>A</sub> = -40 °C to +85 °C, V<sub>DD</sub> = 1.8 V to 5.5 V)

Parameter	Symbol	Conditions	Min	Typ	Max	Units
Instruction cycle time (1)	t <sub>CY</sub>	V <sub>DD</sub> = 2.7 V to 5.5 V	0.67	–	64	μs
		V <sub>DD</sub> = 1.8 V to 5.5 V	0.95	–	64	
		With subsystem clock (fxt)	114	122	125	
TCL0 input frequency	f <sub>TI0</sub>	V <sub>DD</sub> = 2.7 V to 5.5 V	0	–	1.5	MHz
		V <sub>DD</sub> = 1.8 V to 5.5 V			1	MHz
TCL0 input high, low width	t <sub>TIH0</sub> , t <sub>TIL0</sub>	V <sub>DD</sub> = 2.7 V to 5.5 V	0.48	–	–	μs
		V <sub>DD</sub> = 1.8 V to 5.5 V	1.8			
Interrupt input high, low width	t <sub>INTH</sub> , t <sub>INTL</sub>	INT0	(2)	–	–	μs
		INT1, INT2, KS0–KS3	10			
RESET Input Low Width	t <sub>RSL</sub>	Input	10	–	–	μs

**NOTES:**

1. Unless otherwise specified, Instruction Cycle Time condition values assume a main system clock (fx) source.
2. Minimum value for INT0 is based on a clock of 2t<sub>CY</sub> or 128/fx as assigned by the IMOD0 register setting.

www.DataSheet4U.com

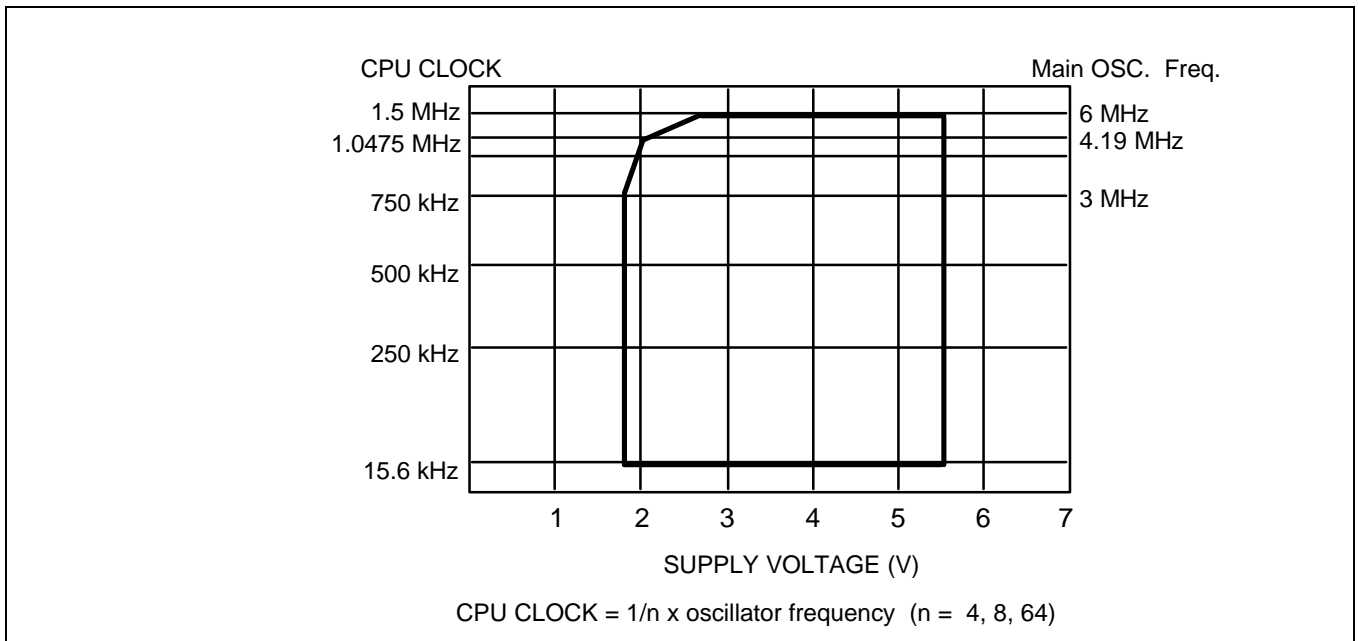

Figure 13-1. Standard Operating Voltage Range

Table 13-7. RAM Data Retention Supply Voltage in Stop Mode

(T<sub>A</sub> = -40 °C to +85 °C)

Parameter	Symbol	Conditions	Min	Typ	Max	Unit
Data retention supply voltage	V <sub>DDDR</sub>	Normal operation	1.5	–	6.5	V
Data retention supply current	I <sub>DDDR</sub>	V <sub>DDDR</sub> = 2.0 V	–	0.1	1	μA
Release signal set time	t <sub>SREL</sub>	Normal operation	0	–	–	μs
Oscillator stabilization wait time (1)	t <sub>WAIT</sub>	Released by RESET	–	2 <sup>17</sup> / fx	–	ms
		Released by interrupt	–	(2)	–	

**NOTES:**

- During oscillator stabilization wait time, all CPU operations must be stopped to avoid instability during oscillator start-up.
- Use the basic timer mode register (BMOD) interval timer to delay execution of CPU instructions during the wait time.

## TIMING WAVEFORMS

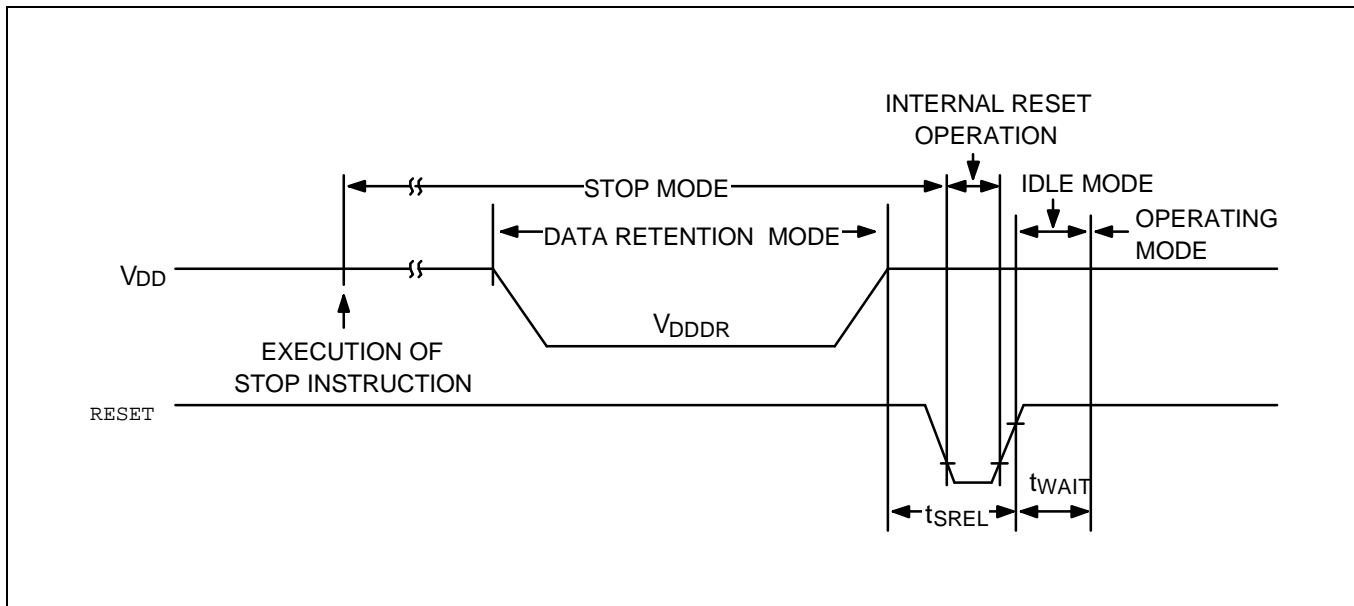

Figure 13-2. Stop Mode Release Timing When Initiated By RESET

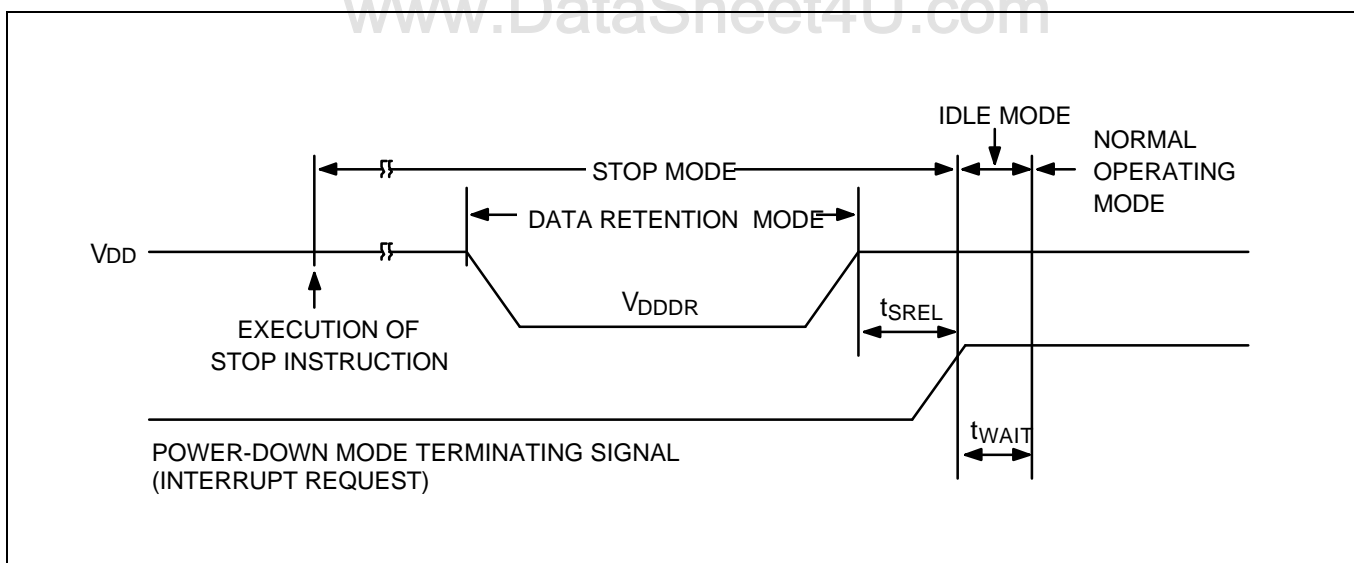
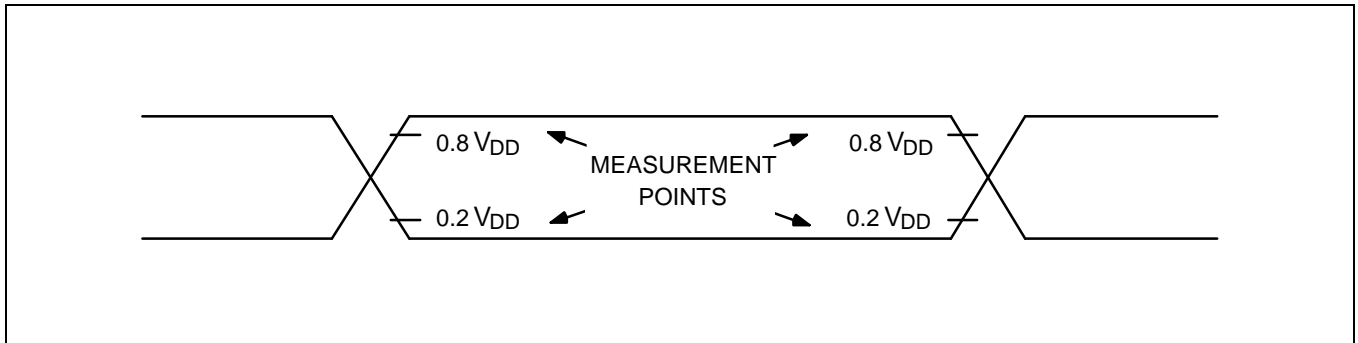
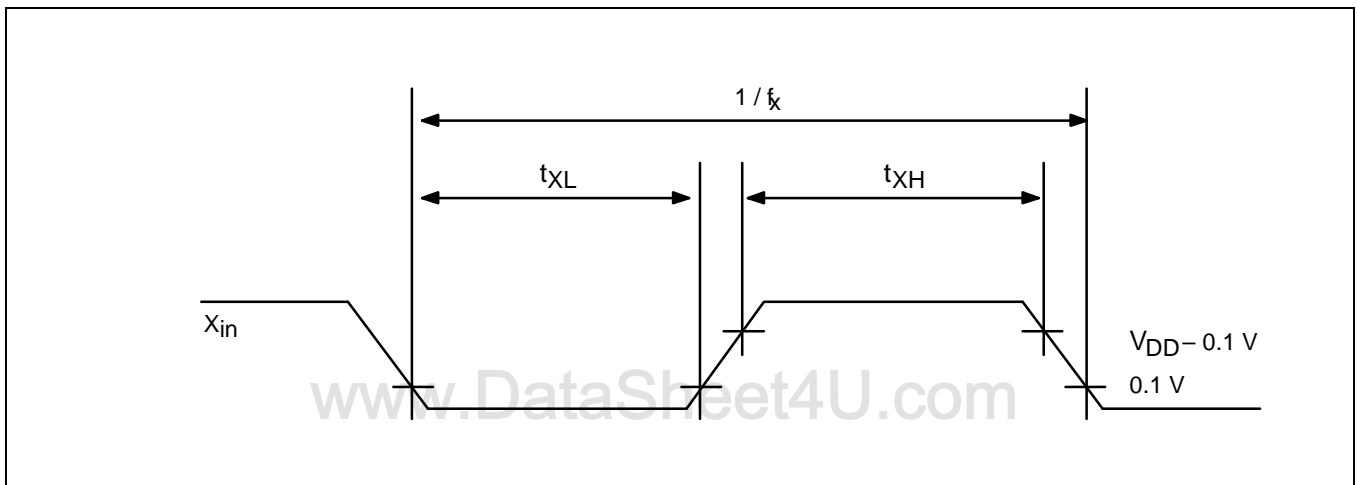
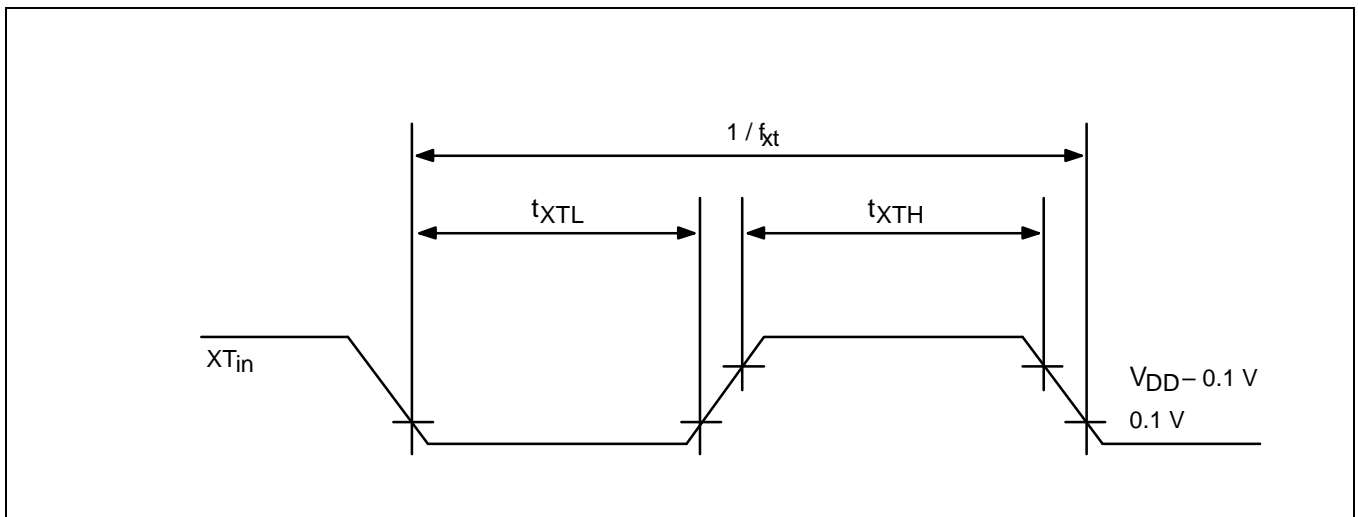

Figure 13-3. Stop Mode Release Timing When Initiated By Interrupt Request

Figure 13-4. A.C. Timing Measurement Points (Except for  $X_{in}$  and  $XT_{in}$ )Figure 13-5. Clock Timing Measurement at  $X_{in}$ Figure 13-6. Clock Timing Measurement at  $XT_{in}$

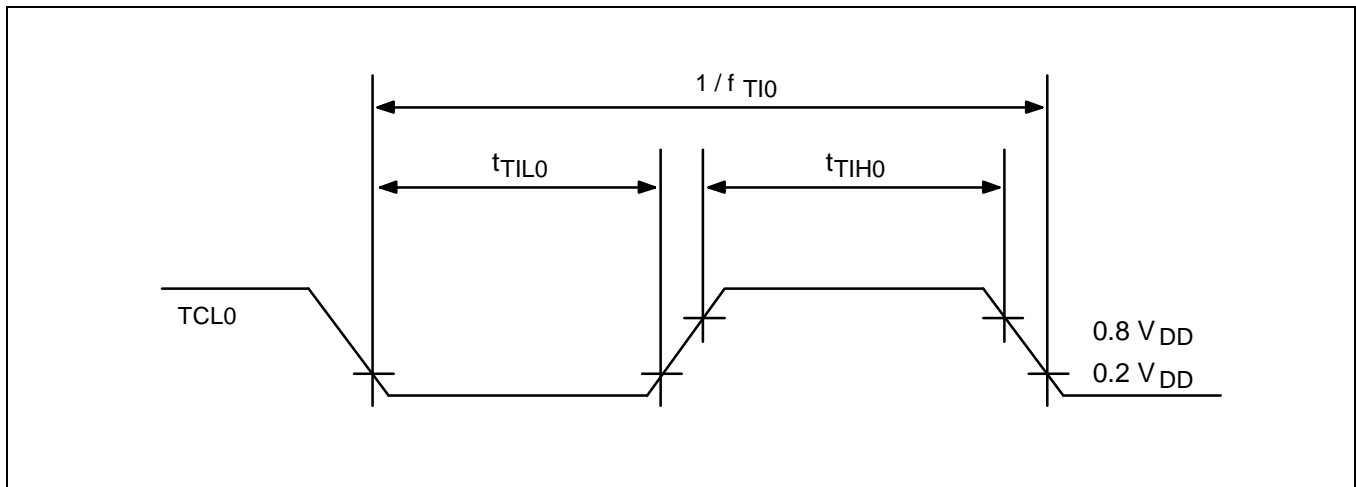

Figure 13-7. TClO Timing

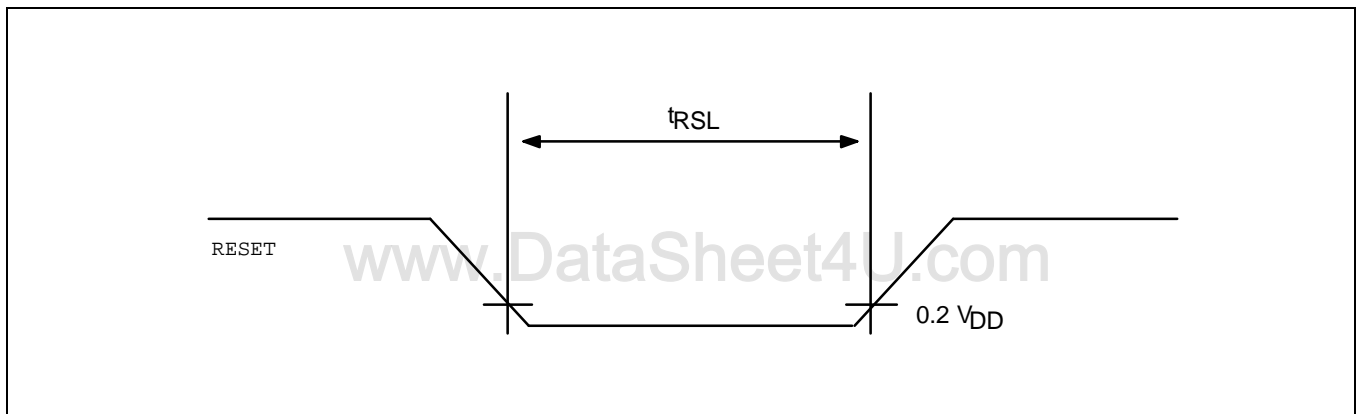

Figure 13-8. Input Timing for RESET Signal

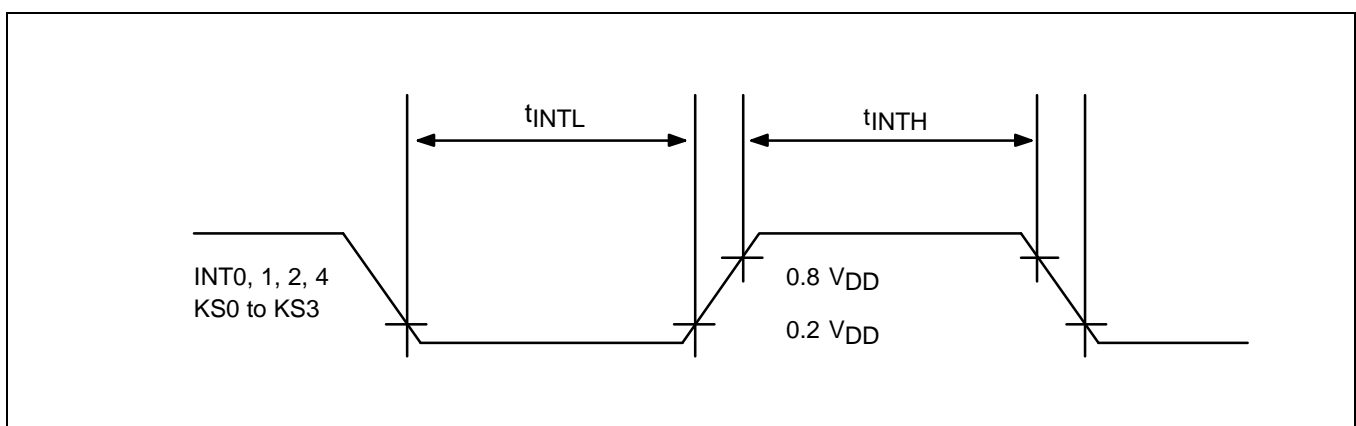

Figure 13-9. Input Timing for External Interrupts and Quasi-Interrupts

# 14 MECHANICAL DATA

## OVERVIEW

The KS57C2302/C2304 microcontroller is available in a 64-pin QFP package (Samsung: 64-QFP-1420F). Package dimensions are shown in Figure 14-1.

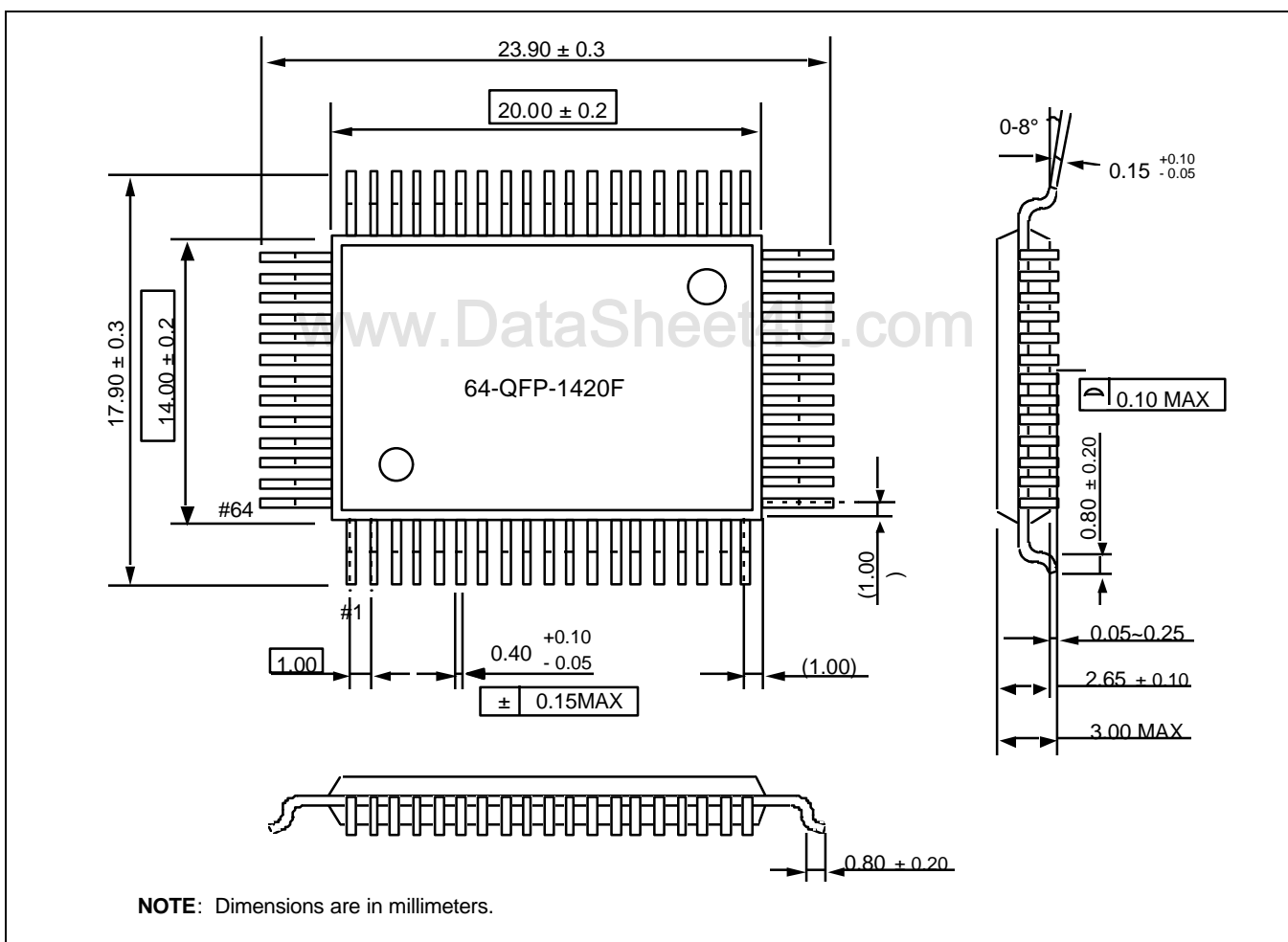

Figure 15-1. 64-QFP-1420F Package Dimensions

NOTES

www.DataSheet4U.com



# 15

## KS57P2304 OTP

### OVERVIEW

The KS57P2304 single-chip CMOS microcontroller is the OTP (One Time Programmable) version of the KS57C2302/C2304 microcontroller. It has an on-chip EPROM instead of masked ROM. The EPROM is accessed by a serial data format.

The KS57P2304 is fully compatible with the KS57C2302/C2304, both in function and in pin configuration. Because of its simple programming requirements, the KS57P2304 is ideal for use as an evaluation chip for the KS57C2304.

www.DataSheet4U.com



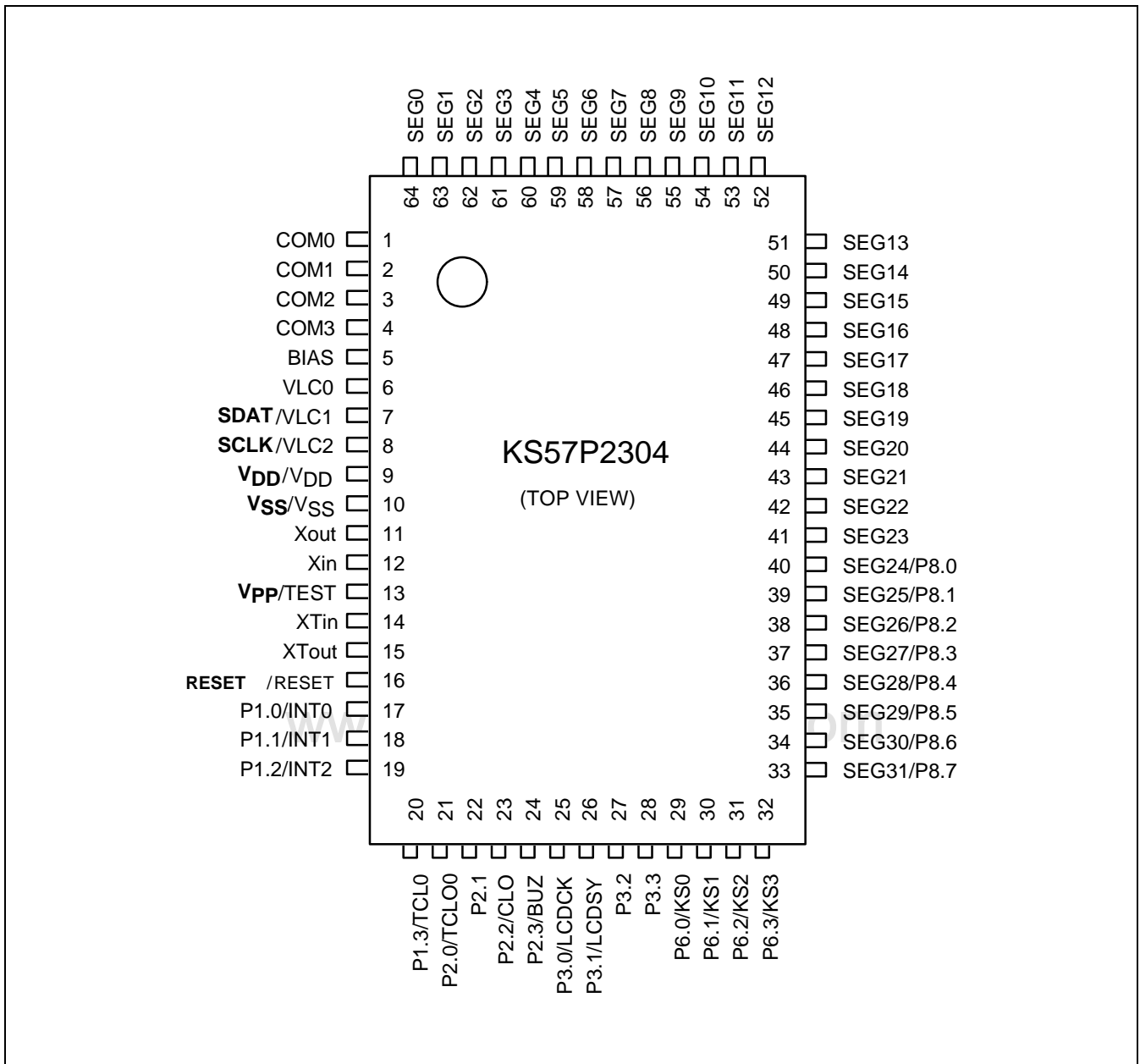

Figure 15-1. KS57P2304 Pin Assignments (64-QFP)

Table 15-1. Pin Descriptions Used to Read/Write the EPROM

Main Chip	During Programming			
Pin Name	Pin Name	Pin No.	I/O	Function
V <sub>LC1</sub>	SDAT	7	I/O	Serial data pin. Output port when reading and input port when writing. Can be assigned as a Input / push-pull output port.
V <sub>LC2</sub>	SCLK	8	I/O	Serial clock pin. Input only pin.
TEST	V <sub>PP</sub> (TEST)	13	I	Power supply pin for EPROM cell writing (indicates that OTP enters into the writing mode). When 12.5 V is applied, OTP is in writing mode and when 5 V is applied, OTP is in reading mode. (Option)
RESET	RESET	16	I	Chip initialization
V <sub>DD</sub> / V <sub>SS</sub>	V <sub>DD</sub> / V <sub>SS</sub>	9/10	I	Logic power supply pin. V <sub>DD</sub> should be tied to +5 V during programming.

Table 15-2. Comparison of KS57P2304 and KS57C2302/C2304 Features

Characteristic	KS57P2304	KS57C2302/C2304
Program Memory	4-Kbyte EPROM	2-K / 4-Kbyte mask ROM
Operating Voltage (V <sub>DD</sub> )	2.0 V to 5.5 V at 4.19 MHz 1.8 V to 5.5 V at 3 MHz	2.0 V to 5.5 V at 4.19 MHz 1.8 V to 5.5 V at 3 MHz
OTP Programming Mode	V <sub>DD</sub> = 5 V, V <sub>PP</sub> (TEST) = 12.5 V	–
Pin Configuration	64 QFP	64 QFP
EPROM Programmability	User Program 1 time	Programmed at the factory

## OPERATING MODE CHARACTERISTICS

When 12.5 V is supplied to the V<sub>pp</sub> (TEST) pin of the KS57P2304, the EPROM programming mode is entered. The operating mode (read, write, or read protection) is selected according to the input signals to the pins listed in Table 15-3 below.

Table 15-3. Operating Mode Selection Criteria

V <sub>DD</sub>	V <sub>pp</sub> (TEST)	REG/ MEM	Address (A15-A0)	R/W	Mode
5 V	5 V	0	0000H	1	EPROM read
	12.5 V	0	0000H	0	EPROM program
	12.5 V	0	0000H	1	EPROM verify
	12.5 V	1	0E3FH	0	EPROM read protection

**NOTE:** "0" means low level; "1" means high level.

Table 15-4. D.C. Electrical Characteristics

(T<sub>A</sub> = -40 °C to +85 °C, V<sub>DD</sub> = 1.8 V to 5.5 V)

Parameter	Symbol	Conditions	Min	Typ	Max	Units
Input high voltage	V <sub>IH1</sub>	All input pins except those specified below for V <sub>IH2</sub> , V <sub>IH3</sub>	0.7 V <sub>DD</sub>	–	V <sub>DD</sub>	V
	V <sub>IH2</sub>	Ports 1, 6, and RESET	0.8 V <sub>DD</sub>	–	V <sub>DD</sub>	
	V <sub>IH3</sub>	X <sub>IN</sub> , X <sub>OUT</sub> , and XT <sub>IN</sub>	V <sub>DD</sub> - 0.1	–	V <sub>DD</sub>	
Input low voltage	V <sub>IL1</sub>	Ports 2 and 3	–	–	0.3 V <sub>DD</sub>	V
	V <sub>IL2</sub>	Ports 1, 6 and RESET	–	–	0.2 V <sub>DD</sub>	
	V <sub>IL3</sub>	X <sub>IN</sub> , X <sub>OUT</sub> , and XT <sub>IN</sub>	–	–	0.1	
Output high voltage	V <sub>OH1</sub>	V <sub>DD</sub> = 4.5 V to 5.5 V I <sub>OH</sub> = -1 mA Ports 2, 3, 6 and BIAS	V <sub>DD</sub> - 1.0	–	–	V
	V <sub>OH2</sub>	V <sub>DD</sub> = 4.5 V to 5.5 V I <sub>OH</sub> = -100 μA Port 8 only	V <sub>DD</sub> - 2.0	–	–	
Output low voltage	V <sub>OL1</sub>	V <sub>DD</sub> = 4.5 V to 5.5 V I <sub>OL</sub> = 15 mA, Ports 2, 3, 6	–	0.4	2	V
	V <sub>OL2</sub>	V <sub>DD</sub> = 4.5 V to 5.5 V I <sub>OL</sub> = 100 μA; Port 8 only	–	–	1	
Input high leakage current	I <sub>LIH1</sub>	V <sub>IN</sub> = V <sub>DD</sub> All input pins except those specified below for I <sub>LIH2</sub>	–	–	3	μA
	I <sub>LIH2</sub>	V <sub>IN</sub> = V <sub>DD</sub> X <sub>IN</sub> , X <sub>OUT</sub> and XT <sub>IN</sub>	–	–	20	
Input low leakage current	I <sub>LIL1</sub>	V <sub>IN</sub> = 0 V All input pins except X <sub>IN</sub> , X <sub>OUT</sub> , and XT <sub>IN</sub>	–	–	-3	μA
	I <sub>LIL2</sub>	V <sub>IN</sub> = 0 V X <sub>IN</sub> , X <sub>OUT</sub> , and XT <sub>IN</sub>	–	–	-20	
Output high leakage current	I <sub>LOH1</sub>	V <sub>OUT</sub> = V <sub>DD</sub> All output pins	–	–	3	μA
Output low leakage current	I <sub>LOL</sub>	V <sub>OUT</sub> = 0 V All output pins	–	–	-3	

Table 15-4. D.C. Electrical Characteristics (Continued)

(T<sub>A</sub> = -40 °C to +85 °C, V<sub>DD</sub> = 1.8 V to 5.5 V)

Parameter	Symbol	Conditions	Min	Typ	Max	Units
Pull-up resistor	R <sub>L1</sub>	V <sub>IN</sub> = 0 V; V <sub>DD</sub> = 5 V Ports 1, 2, 3, 6	25	50	100	KΩ
		V <sub>DD</sub> = 3 V	50	100	200	
	R <sub>L2</sub>	V <sub>IN</sub> = 0 V; V <sub>DD</sub> = 5 V RESET	100	250	400	
		V <sub>DD</sub> = 3 V	200	500	800	
LCD voltage dividing resistor	R <sub>LCD</sub>	T <sub>A</sub> = 25 °C	100	150	200	
COM output impedance	R <sub>COM</sub>	V <sub>DD</sub> = 5 V	-	3	6	
		V <sub>DD</sub> = 3 V		5	15	
SEG output impedance	R <sub>SEG</sub>	V <sub>DD</sub> = 5 V		3	6	
		V <sub>DD</sub> = 3 V		5	15	
COM output voltage deviation	V <sub>DC</sub>	V <sub>DD</sub> = 5 V (VLC0-COMi) I <sub>o</sub> = ± 15μA (i= 0-3)	-	± 45	± 90	mV
SEG output voltage deviation	V <sub>DS</sub>	V <sub>DD</sub> = 5 V (VLC0-SEGi) I <sub>o</sub> = ± 15μA (i= 0-31)	-	± 45	± 90	mV
VLC0 Output voltage	VLC0	T <sub>A</sub> = 25 °C	0.6V <sub>DD</sub> - 0.2	0.6V <sub>DD</sub>	0.6V <sub>DD</sub> + 0.2	V
VLC1 Output voltage	VLC1	T <sub>A</sub> = 25 °C	0.4V <sub>DD</sub> - 0.2	0.4V <sub>DD</sub>	0.4V <sub>DD</sub> + 0.2	
VLC2 Output voltage	VLC2	T <sub>A</sub> = 25 °C	0.2V <sub>DD</sub> - 0.2	0.2V <sub>DD</sub>	0.2V <sub>DD</sub> + 0.2	

Table 15-4. D.C. Electrical Characteristics (Concluded)

(T<sub>A</sub> = -40 °C to +85 °C, V<sub>DD</sub> = 1.8 V to 5.5 V)

Parameter	Symbol	Conditions	Min	Typ	Max	Units	
Supply Current (1)	I <sub>DD1</sub> (2)	Main operating: V <sub>DD</sub> = 5 V ± 10% CPU = fx/4 SCMOD = 0000B Crystal oscillator C1 = C2 = 22 pF	6.0 MHz 4.19 MHz	-	3.5 2.5	8 5.5	mA
		V <sub>DD</sub> = 3 V ± 10%	6.0 MHz 4.19 MHz		1.6 1.2	4 3	
	I <sub>DD2</sub> (2)	Main idle mode; V <sub>DD</sub> = 5 V ± 10% CPU = fx/4 SCMOD = 0000B Crystal oscillator C1 = C2 = 22 pF	6.0 MHz 4.19 MHz	-	1 0.9	2.5 2	
		V <sub>DD</sub> = 3 V ± 10%	6.0 MHz 4.19 MHz		0.5 0.4	1.0 0.8	
	I <sub>DD3</sub>	Sub operating: V <sub>DD</sub> = 3 V ± 10% CPU = fxt/4, SCMOD = 1001B 32 kHz crystal oscillator		-	15	30	μA
	I <sub>DD4</sub>	Sub idle mode: V <sub>DD</sub> = 3 V ± 10% CPU = fxt/4, SCMOD = 1001B 32 kHz crystal oscillator		-	6	15	
I <sub>DD5</sub>	Stop mode: V <sub>DD</sub> = 5 V ± 10% CPU = fxt/4, SCMOD = 1101B						
I <sub>DD6</sub> (3)	Stop mode: V <sub>DD</sub> = 5 V ± 10% CPU = fx/4, SCMOD = 0100B		-	0.5	3		

**NOTES:**

- D.C. electrical values for supply current (I<sub>DD1</sub> to I<sub>DD6</sub>) do not include current drawn through internal pull-up resistors and through LCD voltage dividing resistors.
- Data includes the power consumption for sub-system clock oscillation.
- When the system clock mode register, SCMOD, is set to 0100B, the sub-system clock oscillation stops. The main-system clock oscillation stops by the STOP instruction.

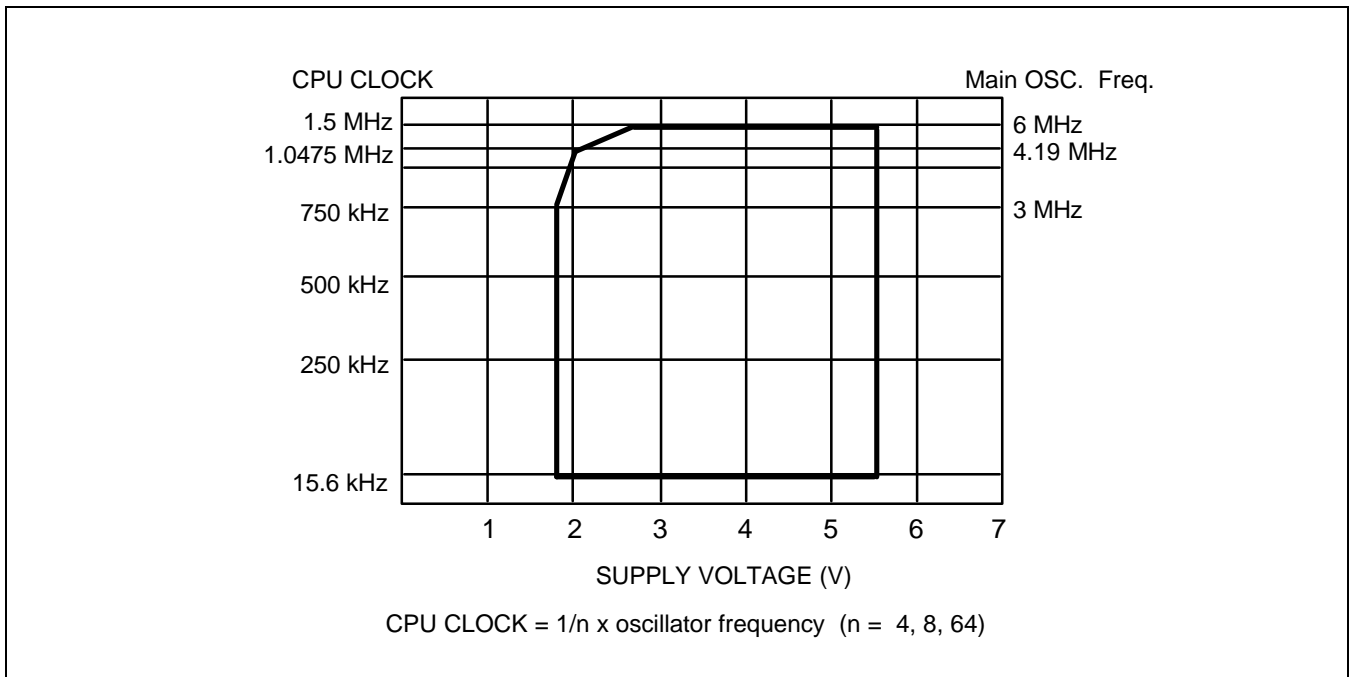
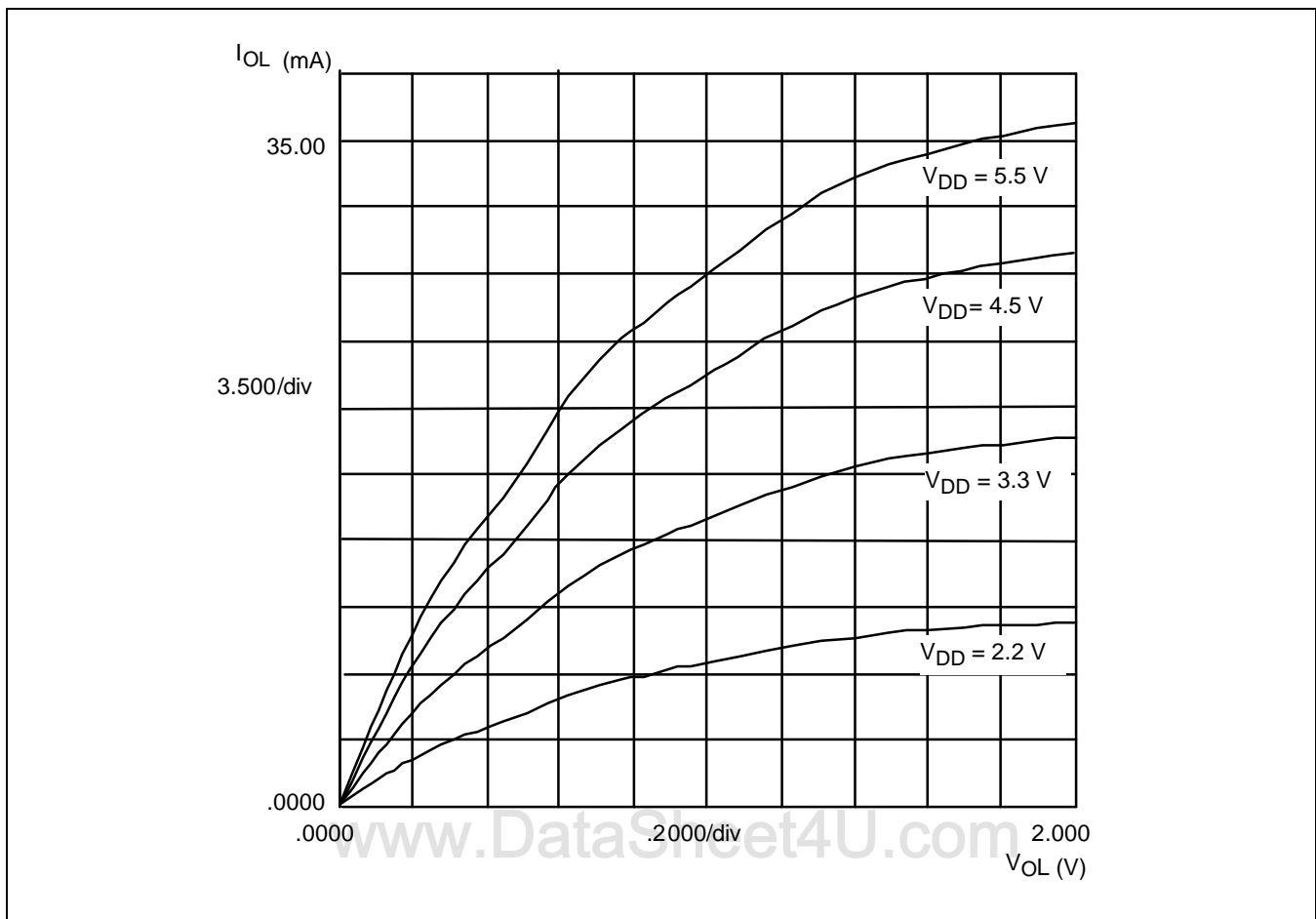

Figure 15-2. Standard Operating Voltage Range

www.DataSheet4U.com

Figure 15-3. Port 2  $I_{OL}$  vs  $V_{OL}$  Curve

# 16

## Development Tools

### OVERVIEW

Samsung provides a powerful and easy-to-use development support system in turnkey form. The development support system is configured with a host system, debugging tools, and support software. For the host system, any standard computer that operates with MS-DOS as its operating system can be used. One type of debugging tool including hardware and software is provided: the sophisticated and powerful in-circuit emulator, SMDS2+, for KS57, KS86, KS88 families of microcontrollers. The SMDS2+ is a new and improved version of SMDS2. Samsung also offers support software that includes debugger, assembler, and a program for setting options.

### SHINE

Samsung Host Interface for In-Circuit Emulator, SHINE, is a multi-window based debugger for SMDS2+. SHINE provides pull-down and pop-up menus, mouse support, function/hot keys, and context-sensitive hyper-linked help. It has an advanced, multiple-windowed user interface that emphasizes ease of use. Each window can be sized, moved, scrolled, highlighted, added, or removed completely.

### SAMA ASSEMBLER

The Samsung Arrangeable Microcontroller (SAM) Assembler, SAMA, is a universal assembler, and generates object code in standard hexadecimal format. Assembled program code includes the object code that is used for ROM data and required SMDS program control data. To assemble programs, SAMA requires a source file and an auxiliary definition (DEF) file with device specific information.

### SASM57

The SASM57 is an relocatable assembler for Samsung's KS57-series microcontrollers. The SASM57 takes a source file containing assembly language statements and translates into a corresponding source code, object code and comments. The SASM57 supports macros and conditional assembly. It runs on the MS-DOS operating system. It produces the relocatable object code only, so the user should link object file. Object files can be linked with other object files and loaded into memory.

### HEX2ROM

HEX2ROM file generates ROM code from HEX file which has been produced by assembler. ROM code must be needed to fabricate a microcontroller which has a mask ROM. When generating the ROM code (.OBJ file) by HEX2ROM, the value 'FF' is filled into the unused ROM area upto the maximum ROM size of the target device automatically.

### TARGET BOARDS

Target boards are available for all KS57-series microcontrollers. All required target system cables and adapters are included with the device-specific target board.

### OTPs

One time programmable microcontroller (OTP) for the KS57C2302/C2304 microcontroller and OTP programmer (Gang) are now available.





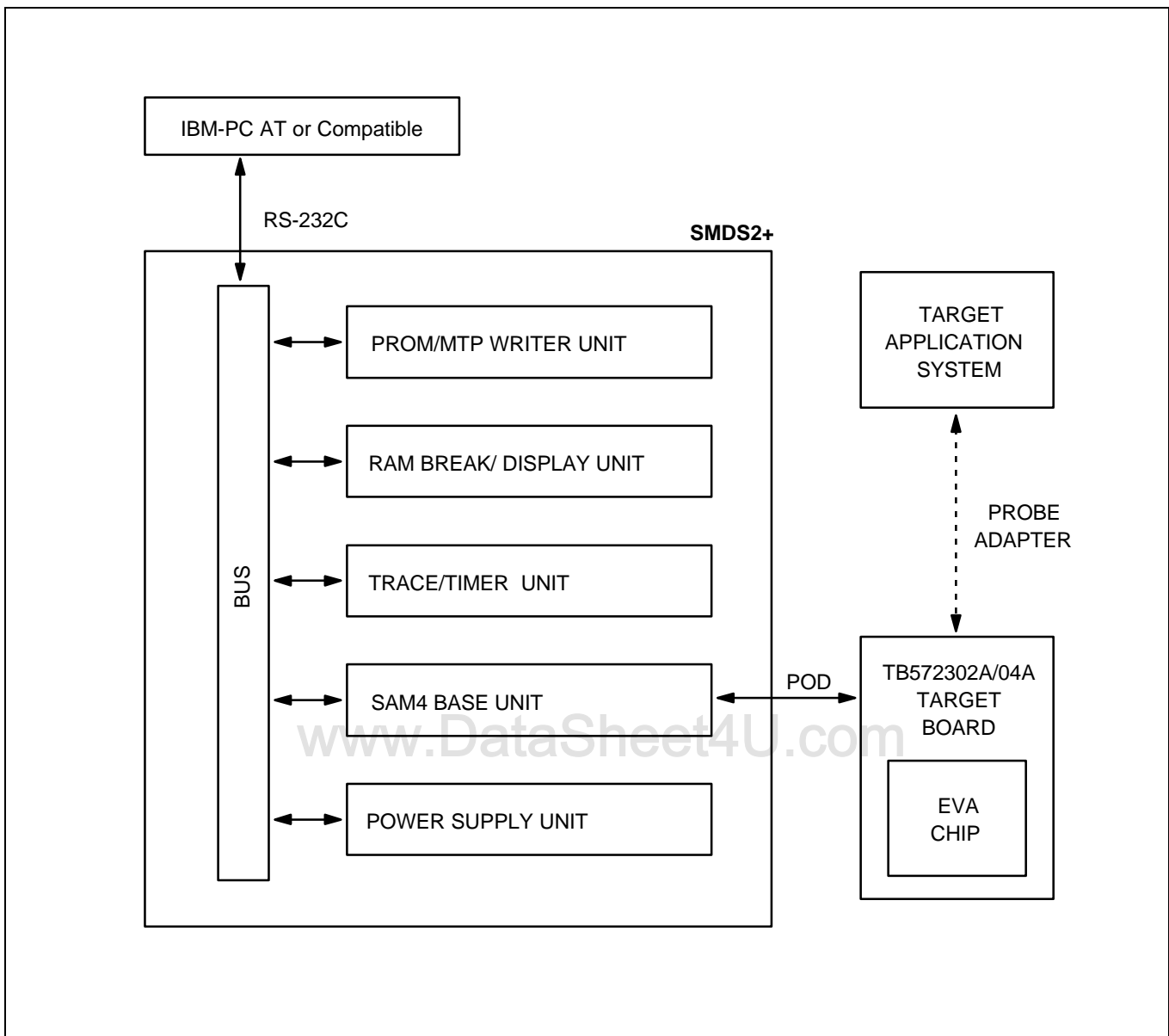

Figure 16-1. SMDS Product Configuration (SMDS2+)

## TB572302A/04A TARGET BOARD

The TB572302A/04A target board is used for the KS57C2302/C2304/P2304 microcontroller. It is supported by the SMDS2+ development system.

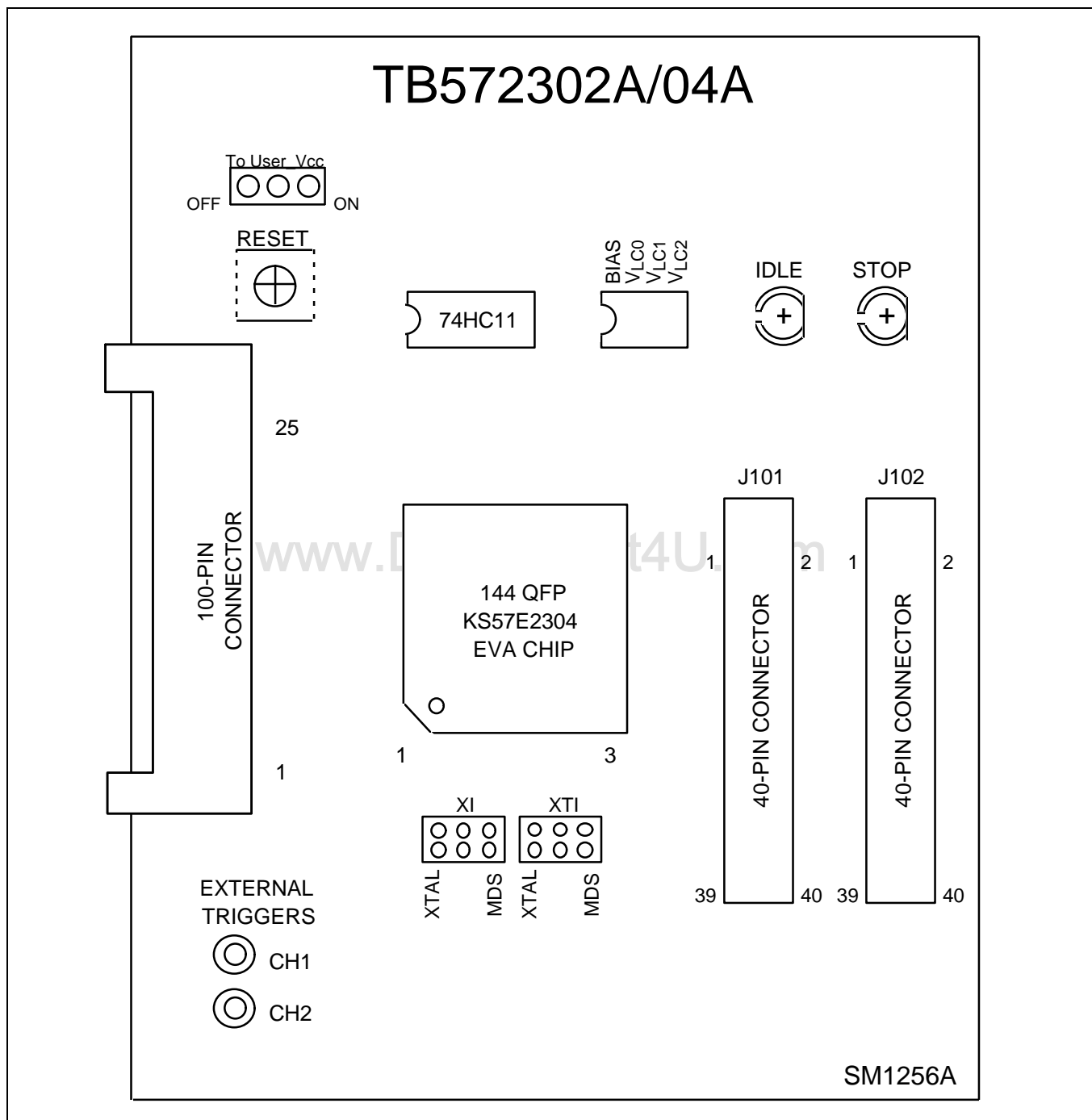

Figure 16-2. TB572302A/04A Target Board Configuration

Table 16-1. Power Selection Settings for TB572302A/04A



'To User_Vcc' Settings	Operating Mode	Comments
To User_Vcc OFF  ON		The SMDS2/SMDS2+ supplies V <sub>CC</sub> to the target board (evaluation chip) and the target system.
To User_Vcc OFF  ON		The SMDS2/SMDS2+ supplies V <sub>CC</sub> only to the target board (evaluation chip). The target system must have its own power supply.

Table 16-2. Main-clock Selection Settings for TB572302A/04A

Main Clock Setting	Operating Mode	Comments
XTAL  MDS		Set the XI switch to "MDS" when the target board is connected to the SMDS2/SMDS2+.
XTAL  MDS		Set the XI switch to "XTAL" when the target board is used as a standalone unit, and is not connected to the SMDS2/SMDS2+.

Table 16-3. Sub-clock Selection Settings for TB572302A/04A

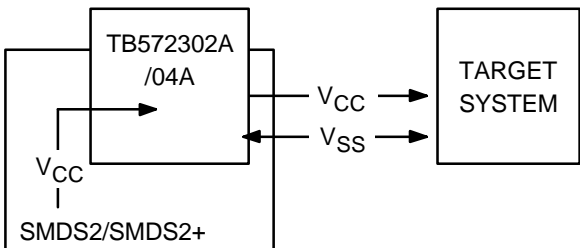
Sub Clock Setting	Operating Mode	Comments
		Set the XTI switch to “MDS” when the target board is connected to the SMDS2/SMDS2+.
		Set the XTI switch to “XTAL” when the target board is used as a standalone unit, and is not connected to the SMDS2/SMDS2+.

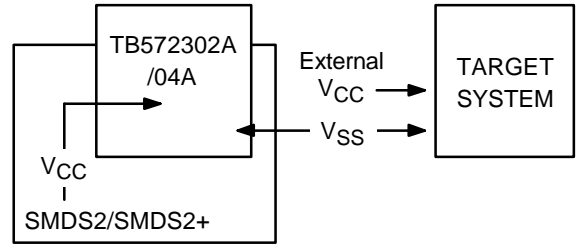
Table 16-4. Using Single Header Pins as the Input Path for External Trigger Sources

Target Board Part	Comments
<p>EXTERNAL TRIGGERS</p> <p>○ CH1</p> <p>○ CH2</p>	 <p>Connector from external trigger sources of the application system</p> <p>You can connect an external trigger source to one of the two external trigger channels (CH1 or CH2) for the SMDS2+ breakpoint and trace functions.</p>

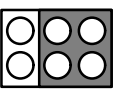
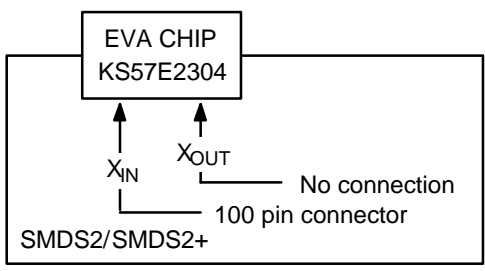
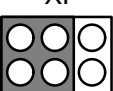
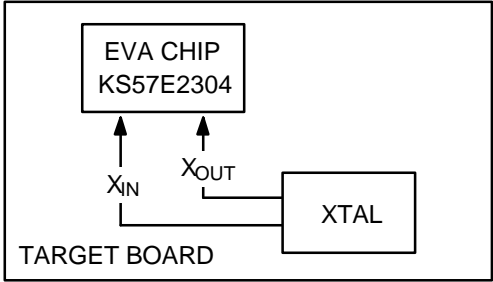
**IDLE LED**

This LED is ON when the evaluation chip (KS57E2304) is in idle mode.

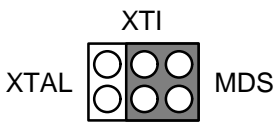
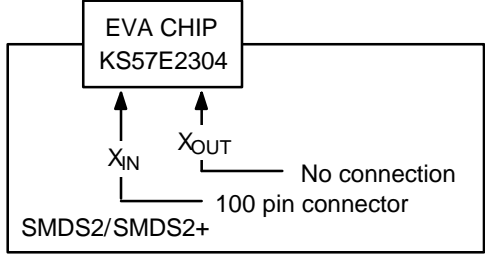
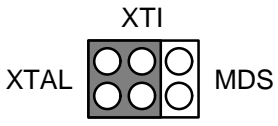
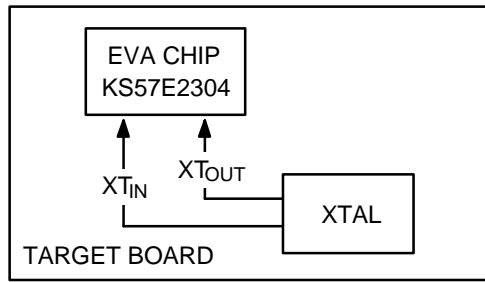
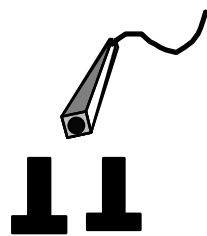
**STOP LED**

This LED is ON when the evaluation chip (KS57E2304) is in stop mode.

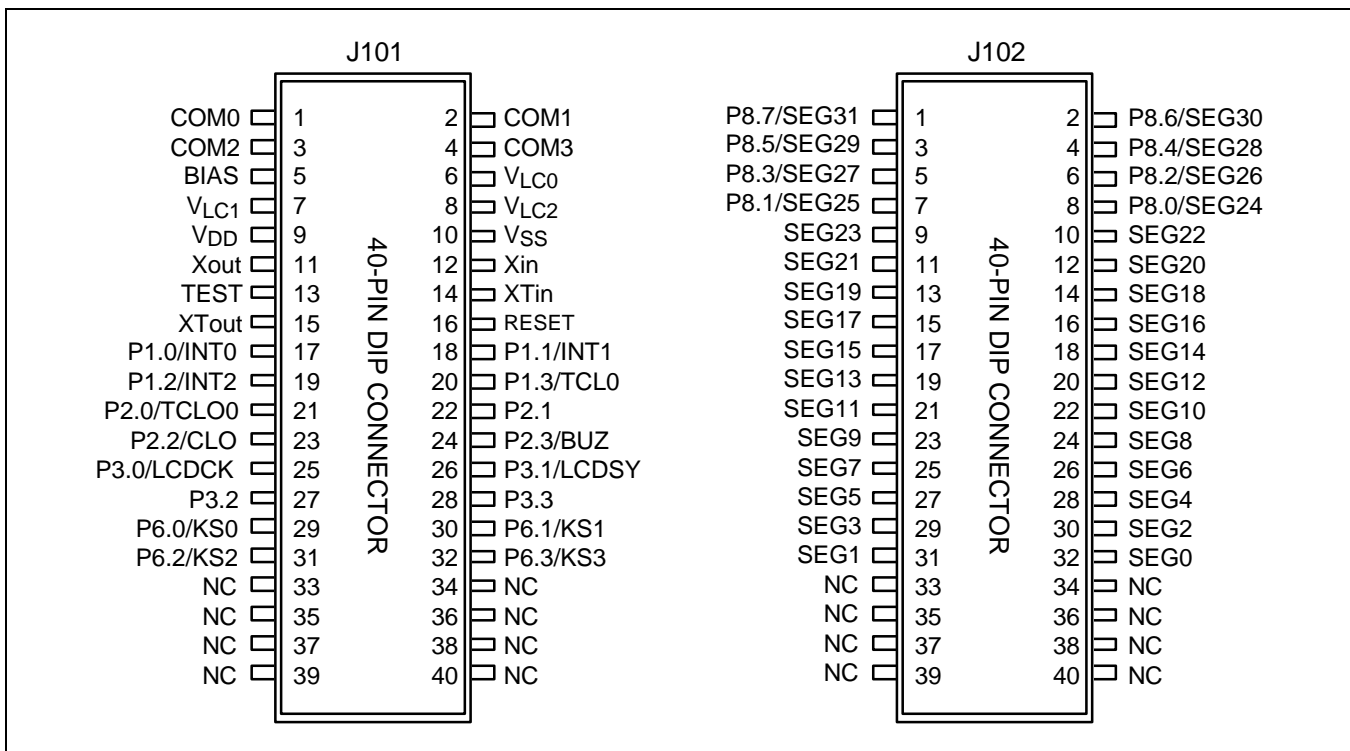

Figure 16-3. 40-Pin Connectors for TB572302A/04A

www.DataSheet4U.com

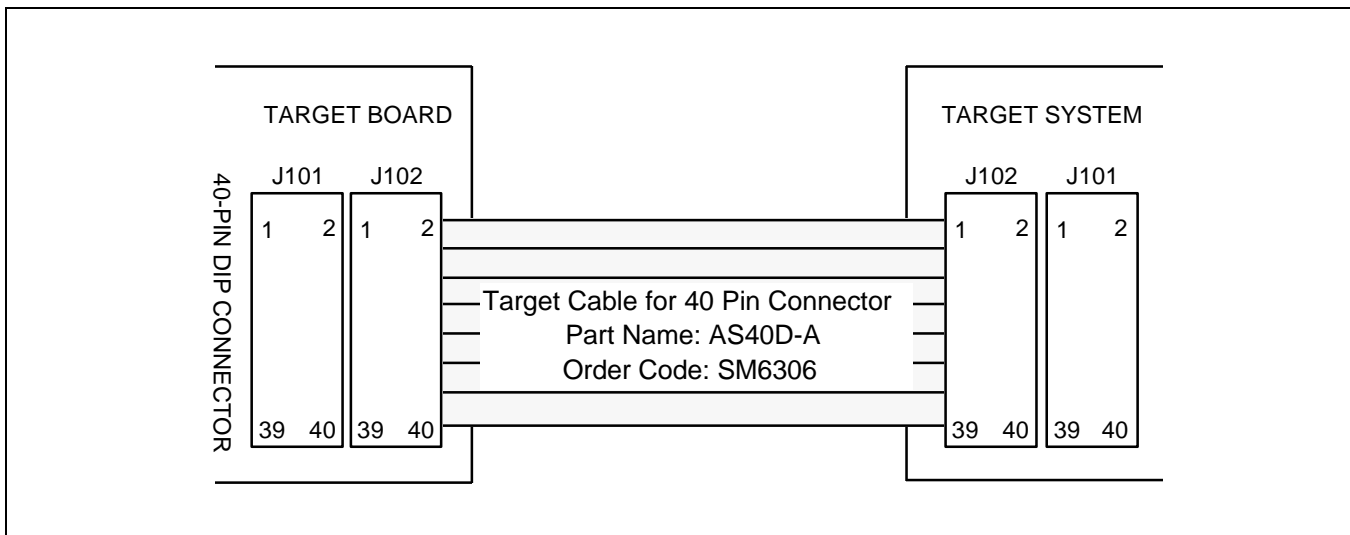

Figure 16-4. TB572302A/04A Adapter Cable for 64-QFP Package (KS57C2302/C2304/P2304)

# KS57 SERIES MASK ROM ORDER FORM

## Product description:

Device Number: KS57C \_\_\_\_\_ - \_\_\_\_\_ (write down the ROM code number)

Product Order Form:  Package  Pellet  Wafer Package Type: \_\_\_\_\_

## Package Marking (Check One):

Standard

Custom A  
(Max 10 chars)

Custom B  
(Max 10 chars each line)

<b>SEC</b>	@ YWW
Device Name	

@ YWW
Device Name
_____

@ YWW
_____
_____

@ : Assembly site code, Y : Last number of assembly year, WW : Week of assembly

## Delivery Dates and Quantities:

Deliverable	Required Delivery Date	Quantity	Comments
ROM code	-	Not applicable	See ROM Selection Form
Customer sample			
Risk order			See Risk Order Sheet

Please answer the following questions:

### ☞ For what kind of product will you be using this order?

- New product
  Upgrade of an existing product  
 Replacement of an existing product
  Other

If you are replacing an existing product, please indicate the former product name  
( \_\_\_\_\_ )

### ☞ What are the main reasons you decided to use a Samsung microcontroller in your product?

Please check all that apply.

- Price
  Product quality
  Features and functions  
 Development system
  Technical support
  Delivery on time  
 Used same micom before
  Quality of documentation
  Samsung reputation

Mask Charge (US\$ / Won): \_\_\_\_\_

## Customer Information:

Company Name: \_\_\_\_\_ Telephone number: \_\_\_\_\_

Signatures: \_\_\_\_\_

(Person placing the order)

(Technical Manager)

(For duplicate copies of this form, and for additional ordering information, please contact your local Samsung sales representative. Samsung sales offices are listed on the back cover of this book.)

www.DataSheet4U.com

# KS57 SERIES

## REQUEST FOR PRODUCTION AT CUSTOMER RISK

**Customer Information:**

Company Name: \_\_\_\_\_

Department: \_\_\_\_\_

Telephone Number: \_\_\_\_\_ Fax: \_\_\_\_\_

Date: \_\_\_\_\_

**Risk Order Information:**

Device Number: KS57C \_\_\_\_\_ - \_\_\_\_\_ (write down the ROM code number)

Package: Number of Pins: \_\_\_\_\_ Package Type: \_\_\_\_\_

Intended Application: \_\_\_\_\_

Product Model Number: \_\_\_\_\_

www.DataSheet4U.com

**Customer Risk Order Agreement:**

We hereby request SEC to produce the above named product in the quantity stated below. We believe our risk order product to be in full compliance with all SEC production specifications and, to this extent, agree to assume responsibility for any and all production risks involved.

**Order Quantity and Delivery Schedule:**

Risk Order Quantity: \_\_\_\_\_ PCS

Delivery Schedule:

Delivery Date (s)	Quantity	Comments

**Signatures:**

 \_\_\_\_\_  
 (Person Placing the Risk Order)

 \_\_\_\_\_  
 (SEC Sales Representative)

(For duplicate copies of this form, and for additional ordering information, please contact your local Samsung sales representative. Samsung sales offices are listed on the back cover of this book.)



www.DataSheet4U.com

# KS57C2302 MASK OPTION SELECTION FORM

**Device Number:** KS57C2302-\_\_\_\_\_ (write down the ROM code number)

**Attachment (Check one):**  Diskette  PROM

**Customer Checksum:** \_\_\_\_\_

**Company Name:** \_\_\_\_\_

**Signature (Engineer):** \_\_\_\_\_

Please answer the following questions:

 **Application** (Product Model ID: \_\_\_\_\_)

- |                                       |   |  |
|---------------------------------------|---|--|
| <input type="checkbox"/> Audio        | <input type="checkbox"/> Video          | <input type="checkbox"/> Telecom           |
| <input type="checkbox"/> LCD Databank | <input type="checkbox"/> Caller ID      | <input type="checkbox"/> LCD Game          |
| <input type="checkbox"/> Industrials  | <input type="checkbox"/> Home Appliance | <input type="checkbox"/> Office Automation |
| <input type="checkbox"/> Remocon      | <input type="checkbox"/> Other          |  |

Please describe in detail its application

---

(For duplicate copies of this form, and for additional ordering information, please contact your local Samsung sales representative. Samsung sales offices are listed on the back cover of this book.)

www.DataSheet4U.com

# KS57C2304 MASK OPTION SELECTION FORM

**Device Number:** KS57C2304-\_\_\_\_\_ (write down the ROM code number)

**Attachment (Check one):**  Diskette  PROM

**Customer Checksum:** \_\_\_\_\_

**Company Name:** \_\_\_\_\_

**Signature (Engineer):** \_\_\_\_\_

Please answer the following questions:

 **Application** (Product Model ID: \_\_\_\_\_)

- |                                       |   |  |
|---------------------------------------|---|--|
| <input type="checkbox"/> Audio        | <input type="checkbox"/> Video          | <input type="checkbox"/> Telecom           |
| <input type="checkbox"/> LCD Databank | <input type="checkbox"/> Caller ID      | <input type="checkbox"/> LCD Game          |
| <input type="checkbox"/> Industrials  | <input type="checkbox"/> Home Appliance | <input type="checkbox"/> Office Automation |
| <input type="checkbox"/> Remocon      | <input type="checkbox"/> Other          |  |

Please describe in detail its application

---

(For duplicate copies of this form, and for additional ordering information, please contact your local Samsung sales representative. Samsung sales offices are listed on the back cover of this book.)

# KS57 SERIES OTP FACTORY WRITING ORDER FORM (1/2)

## Product Description:

Device Number: KS57P\_\_\_\_\_ - \_\_\_\_\_ (write down the ROM code number)

Product Order Form:  Package  Pellet  Wafer

If the product order form is package: Package Type: \_\_\_\_\_

## Package Marking (Check One):

Standard

Custom A  
(Max 10 chars)

Custom B  
(Max 10 chars each line)

<b>SEC</b> @ YWW Device Name
---------------------------------

@ YWW Device Name <input style="width: 100px; height: 15px;" type="text"/>
--

@ YWW <input style="width: 100%; height: 15px;" type="text"/> <input style="width: 100%; height: 15px;" type="text"/>
---

@ : Assembly site code, Y : Last number of assembly year, WW : Week of assembly

## Delivery Dates and Quantity:

ROM Code Release Date	Required Delivery Date of Device	Quantity

Please answer the following questions:

### ☛ What is the purpose of this order?

- New product development
  Upgrade of an existing product  
 Replacement of an existing microcontroller
  Other

If you are replacing an existing microcontroller, please indicate the former microcontroller name  
( \_\_\_\_\_ )

### ☛ What are the main reasons you decided to use a Samsung microcontroller in your product?

Please check all that apply.

- Price
  Product quality
  Features and functions  
 Development system
  Technical support
  Delivery on time  
 Used same micom before
  Quality of documentation
  Samsung reputation

## Customer Information:

Company Name: \_\_\_\_\_ Telephone number \_\_\_\_\_

Signatures: \_\_\_\_\_  
(Person placing the order) (Technical Manager)

(For duplicate copies of this form, and for additional ordering information, please contact your local Samsung sales representative. Samsung sales offices are listed on the back cover of this book.)

www.DataSheet4U.com

# KS57P2304 OTP FACTORY WRITING ORDER FORM (2/2)

**Device Number:** KS57P2304-\_\_\_\_\_ (write down the ROM code number)

**Customer Checksums:** \_\_\_\_\_

**Company Name:** \_\_\_\_\_

**Signature (Engineer):** \_\_\_\_\_

**Read Protection<sup>(1)</sup>:**  **Yes**  **No**

Please answer the following questions:

**☛ Are you going to continue ordering this device?**

**Yes**  **No**

**If so, how much will you be ordering?** \_\_\_\_\_ pcs

**☛ Application (Product Model ID: \_\_\_\_\_)**

- |                                       |   |  |
|---------------------------------------|---|--|
| <input type="checkbox"/> Audio        | <input type="checkbox"/> Video          | <input type="checkbox"/> Telecom           |
| <input type="checkbox"/> LCD Databank | <input type="checkbox"/> Caller ID      | <input type="checkbox"/> LCD Game          |
| <input type="checkbox"/> Industrials  | <input type="checkbox"/> Home Appliance | <input type="checkbox"/> Office Automation |
| <input type="checkbox"/> Remocon      | <input type="checkbox"/> Other          |  |

Please describe in detail its application

---

## NOTES

- Once you choose a read protection, you cannot read again the programming code from the EPROM.
- OTP Writing will be executed in our manufacturing site.
- The writing program is completely verified by a customer. Samsung does not take on any responsibility for errors occurred from the writing program.

---

(For duplicate copies of this form, and for additional ordering information, please contact your local Samsung sales representative. Samsung sales offices are listed on the back cover of this book.)