

isc Silicon NPN Power Transistor

KSD5090

DESCRIPTION

- High Breakdown Voltage-
: $V_{CBO} = 1500V$ (Min)
- High Switching Speed
- High Reliability
- Built-in Damper Diode

APPLICATIONS

- Designed for color TV horizontal output applications

ABSOLUTE MAXIMUM RATINGS($T_a=25^{\circ}C$)

SYMBOL	PARAMETER	VALUE	UNIT
V_{CBO}	Collector-Base Voltage	1500	V
V_{CEO}	Collector-Emitter Voltage	800	V
V_{EBO}	Emitter-Base Voltage	6	V
I_C	Collector Current- Continuous	8	A
I_{CP}	Collector Current-Peak	30	A
P_C	Collector Power Dissipation @ $T_C=25^{\circ}C$	150	W
T_J	Junction Temperature	150	$^{\circ}C$
T_{stg}	Storage Temperature Range	-55~150	$^{\circ}C$

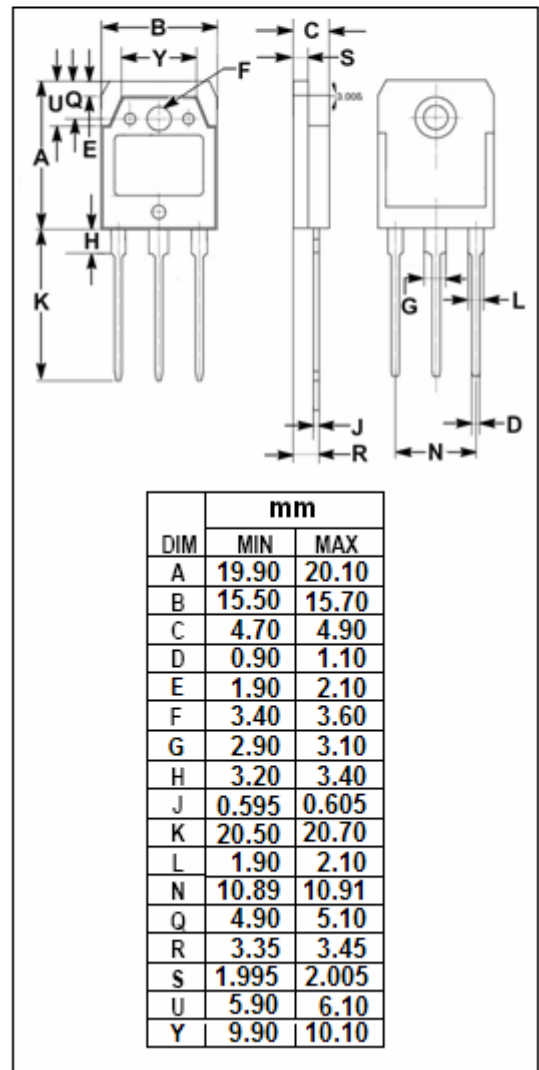
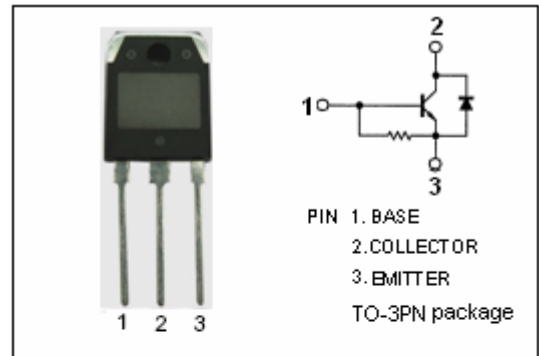

isc Silicon NPN Power Transistor**KSD5090****ELECTRICAL CHARACTERISTICS****T_c=25°C unless otherwise specified**

SYMBOL	PARAMETER	CONDITIONS	MIN	TYP.	MAX	UNIT
V _{CE(sat)}	Collector-Emitter Saturation Voltage	I _C = 6A; I _B = 1.2A			5.0	V
V _{BE(sat)}	Base-Emitter Saturation Voltage	I _C = 6A; I _B = 1.2A			1.5	V
I _{CB0}	Collector Cutoff Current	V _{CB} = 800V ; I _E = 0			10	μ A
I _{EBO}	Emitter Cutoff Current	V _{EB} = 4V ; I _C = 0	40		200	mA
h _{FE-1}	DC Current Gain	I _C = 1A ; V _{CE} = 5V	8			
h _{FE-2}	DC Current Gain	I _C = 6A ; V _{CE} = 5V	5			
V _{ECF}	C-E Diode Forward Voltage	I _F = 8A			2.0	V
t _f	Fall Time	I _C = 6A , I _{B1} = 1.2A ; I _{B2} = -2.4A R _L = 33.3 Ω ; V _{CC} = 200V			0.3	μ s