

KSH13004

SemiHow
Know-How for Semiconductor

KSH13004

Switch Mode series NPN silicon Power Transistor

- High voltage, high speed power switching
- Suitable for switching regulator, inverters motor controls

4 Amperes
 NPN Silicon Power Transistor
 75 Watts

Absolute Maximum Ratings $T_C=25^\circ\text{C}$ unless otherwise noted

CHARACTERISTICS	SYMBOL	RATING	UNIT
Collector-Base Voltage	V_{CBO}	600	V
Collector-Emitter Voltage	V_{CEO}	300	V
Emitter-Base Voltage	V_{EBO}	9	V
Collector Current(DC)	I_C	4	A
Collector Current(Pulse)	I_{CP}	8	A
Base Current	I_B	2	A
Collector Dissipation($T_C=25^\circ\text{C}$)	P_C	75	W
Junction Temperature	T_J	150	$^\circ\text{C}$
Storage Temperature	T_{STG}	-65~150	$^\circ\text{C}$

TO-220
 1. Base
 2. Collector
 3. Emitter



Electrical Characteristics $T_C=25^\circ\text{C}$ unless otherwise noted

CHARACTERISTICS	SYMBOL	Test Condition	Min	Typ.	Max	Unit
Collector-Emitter Breakdown Voltage	V_{CEO}	$I_C=10\text{mA}, I_B=0$	300			V
Emitter Cut-off Current	I_{EBO}	$V_{EB}=9\text{V}, I_C=0$			1	mA
*DC Current Gain	h_{FE1} h_{FE2}	$V_{CE}=5\text{V}, I_C=1\text{A}$ $V_{CE}=5\text{V}, I_C=2\text{A}$	10 8		60 40	
*Collector-Emitter Saturation Voltage	$V_{CE(sat)}$	$I_C=1\text{A}, I_B=0.2\text{A}$ $I_C=2\text{A}, I_B=0.5\text{A}$ $I_C=4\text{A}, I_B=1\text{A}$			0.5 0.6 1	V V V
*Base-Emitter Saturation Voltage	$V_{BE(sat)}$	$I_C=1\text{A}, I_B=0.2\text{A}$ $I_C=2\text{A}, I_B=0.5\text{A}$			1.2 1.6	V V
Output Capacitance	C_{ob}	$V_{CB}=10\text{V}, f=0.1\text{MHz}$		65		pF
Current Gain Bandwidth Product	f_T	$V_{CE}=10\text{V}, I_C=0.5\text{A}$	4			MHz
Turn on Time	t_{on}	$V_{CC}=125\text{V}, I_C=2\text{A}$ $I_{B1}=0.4\text{A}, I_{B2}=-0.4\text{A}$ $R_L=62.5\Omega$			0.8	μs
Storage Time	t_{stg}				4.0	μs
Fall Time	t_F				0.9	μs

* Pulse Test: Pulse Widths $\leq 300\mu\text{s}$, Duty Cycles $\leq 2\%$

Note.

hFE1 Classification	R	19 ~ 28
	O	26 ~ 35
	Y	33 ~ 40

Package Mark information.

S YWW Z KSH13004	S	SemiHow Symbol
	YWW	Y; year code, WW; week code
	Z	hFE1 Classification

Typical Characteristics

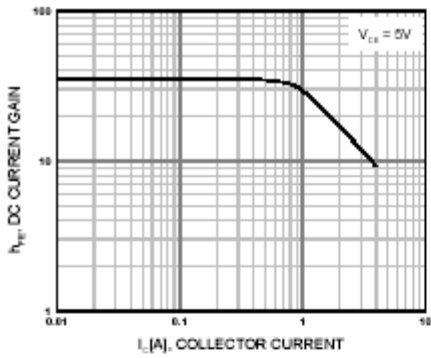

Figure 1. DC current Gain

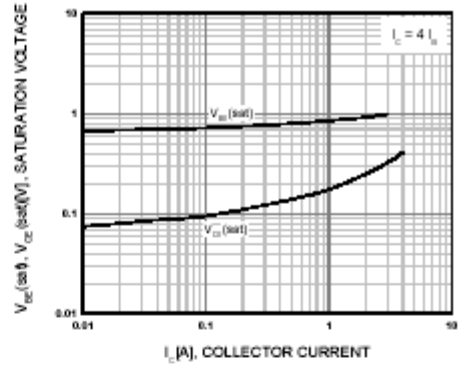

Figure 2. Base-Emitter Saturation Voltage
Collector-Emitter Saturation Voltage

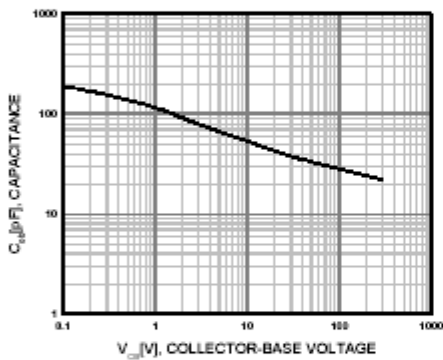

Figure 3. Collector Output Capacitance

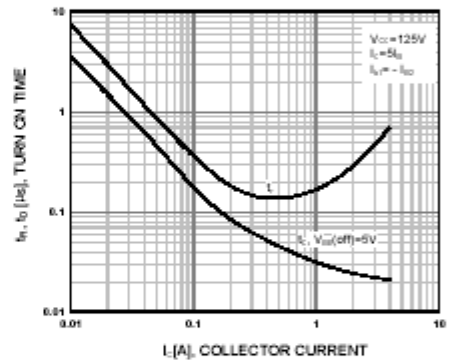

Figure 4. Turn On Time

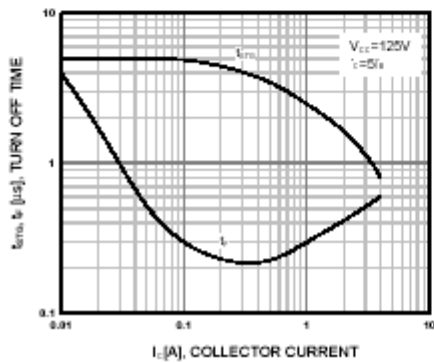

Figure 5. Turn Off Time

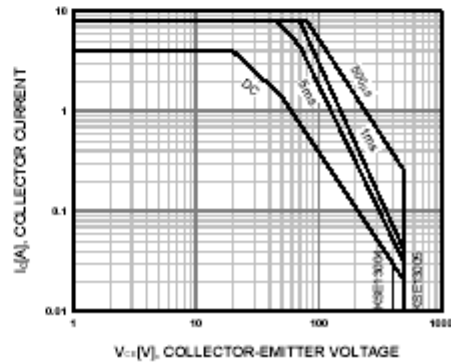
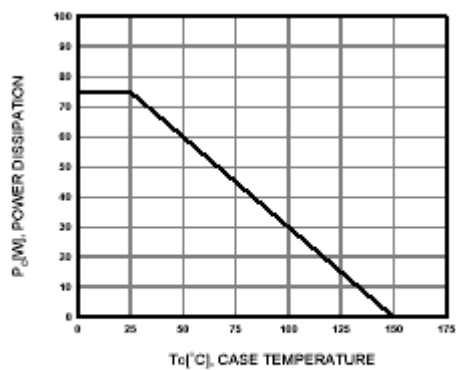
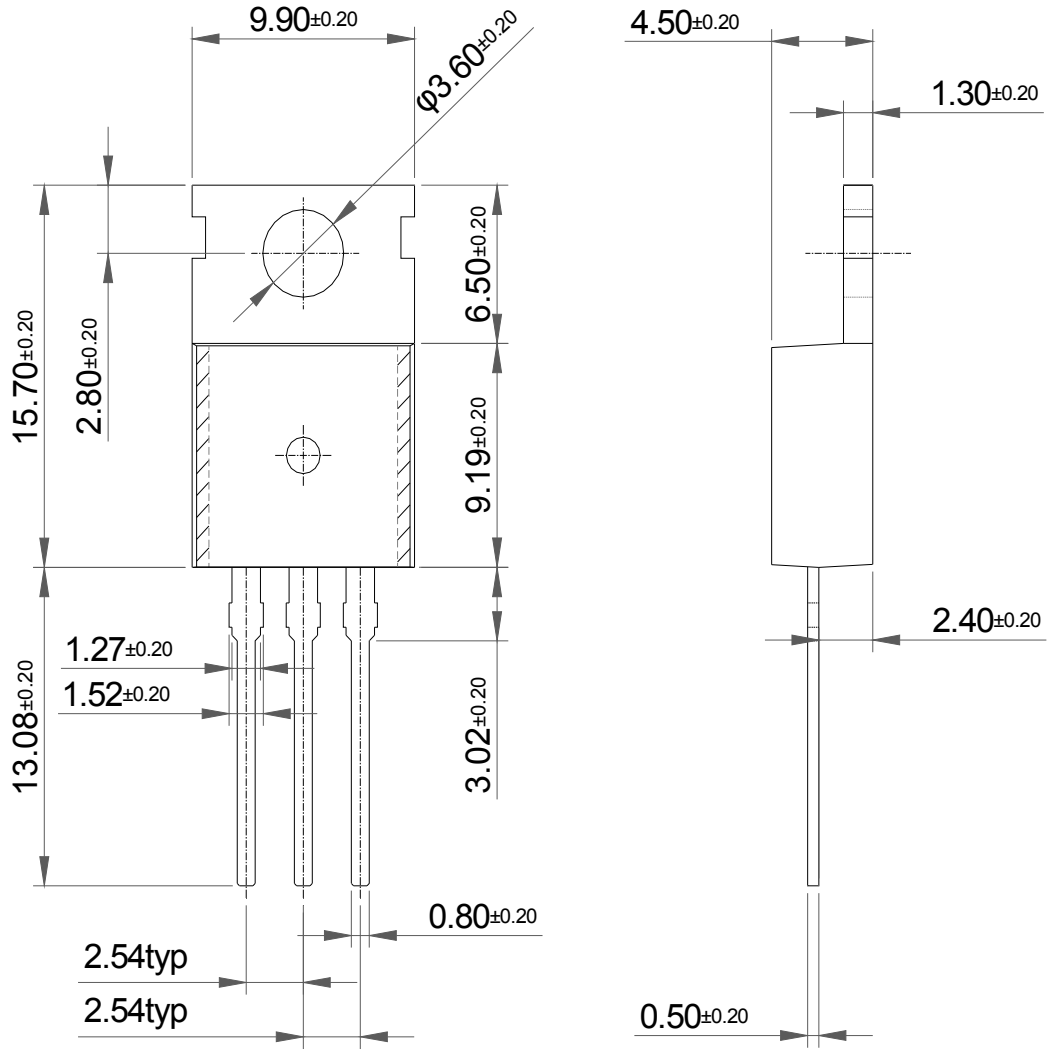

Figure 6. Safe Operating Area

Typical Characteristics (Continued)**Figure 7. Power Derating**

Package Dimension

TO-220 (A)



Package Dimension

TO-220 (B)

