

KSH13007A KSH13007AF

NPN Silicon Power Transistor, $V_{CBO}=700V$, $V_{CEO}=400V$, $I_C=8A$

General Description

- High voltage, high speed power switching
- Suitable for switching regulator, inverters motor controls

Features

- $V_{CBO} = 700V$
- $V_{CEO} = 400V$
- $V_{BEO} = 9V$
- $I_C = 8A$

TO-220



TO-220F

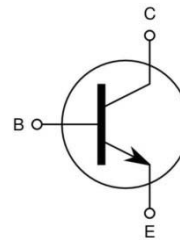
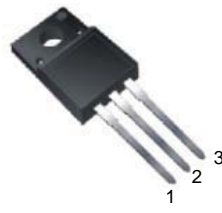

Ordering Information

Ordering number	Package	Pin Assignment			Packing
		1	2	3	
KSH13007A	TO-220	B	C	E	Tube
KSH13007AF	TO-220F	B	C	E	Tube

h_{FE} Classification

Classification	R	O	Y
h_{FE}	15 ~ 28	26 ~ 39	37 ~ 50

* Test Condition : $V_{CE}=5V, I_C=2A$

KSH13007A KSH13007AF

NPN Silicon Power Transistor, $V_{CBO}=700V$, $V_{CEO}=400V$, $I_C=8A$

Absolute Maximum Ratings TC=25°C unless otherwise noted

CHARACTERISTICS	SYMBOL	RATING		UNIT
		TO-220	TO-220F	
Collector-Base Voltage	V_{CBO}	700		V
Collector-Emitter Voltage	V_{CEO}	400		V
Emitter-Base Voltage	V_{EBO}	9		V
Collector Current(DC)	I_C	8		A
Collector Current(Pulse)	I_{CP}	16		A
Base Current	I_B	4		A
Collector Dissipation(Tc=25°C)	P_C	80	40	W
Junction Temperature	T_J	150		°C
Storage Temperature	T_{STG}	-65~150		°C

Electrical Characteristics ⁽¹⁾ TC=25°C unless otherwise noted

CHARACTERISTICS	SYMBOL	Test Condition	Min	Typ.	Max	Unit
Collector-Base Breakdown Voltage	V_{CBO}	$I_C=500\mu A, I_E=0$	700			V
Collector-Emitter Breakdown Voltage	V_{CEO}	$I_C=10mA, I_B=0$	400			V
Emitter Cut-off Current	I_{EBO}	$V_{EB}=9V, I_C=0$			1	mA
DC Current Gain	h_{FE1} h_{FE2}	$V_{CE}=5V, I_C=2A$	8		50	
		$V_{CE}=5V, I_C=5A$	5		30	
Collector-Emitter Saturation Voltage	$V_{CE}(sat)$	$I_C=2A, I_B=0.4A$			1	V
		$I_C=5A, I_B=1A$			2	V
		$I_C=8A, I_B=2A$			3	V
Base-Emitter Saturation Voltage	$V_{BE}(sat)$	$I_C=2A, I_B=0.4A$			1.2	V
		$I_C=5A, I_B=1A$			1.6	V
Output Capacitance	C_{ob}	$V_{CB}=10V, f=0.1MHz$		80		pF
Current Gain Bandwidth Product	f_T	$V_{CE}=10V, I_C=0.5A$	4			MHz
Turn on Time	t_{on}	$V_{CC}=125V, I_C=5A$ $I_{B1}=1A, I_{B2}=-1A$ $R_L=25\Omega$ (Note 2)			1.6	μs
Storage Time	t_{stg}				3.0	μs
Fall Time	t_F				0.7	μs

Notes ;

1. Pulse Test: Pulse Width $\leq 300\mu s$, Duty Cycle $\leq 2\%$

2. Final Test Condition : UI9600, $V_{CC}=5V, I_C=0.5A$ (t_{stg} Class = A : 3.0~3.5, B : 3.5~4.0, C : 4.0~4.5)

Typical Characteristics

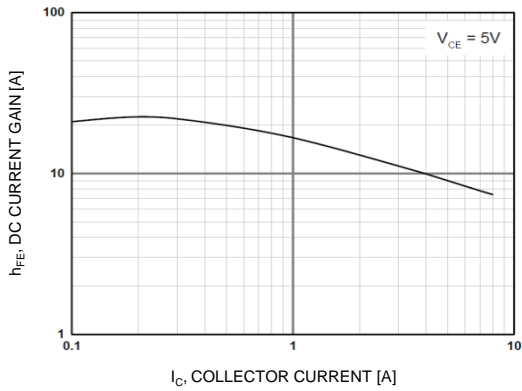
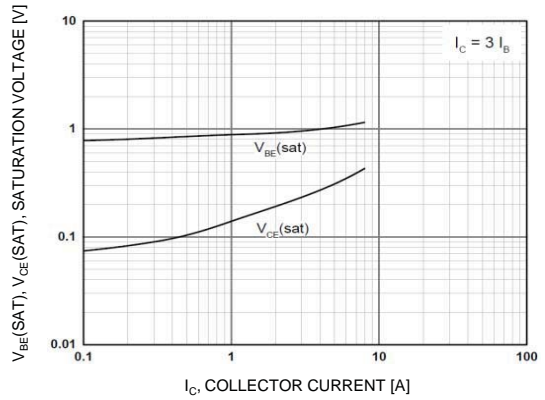

Figure 1. DC Current Gain



**Figure 2. Base-Emitter Saturation Voltage
Collector-Emitter Saturation Voltage**

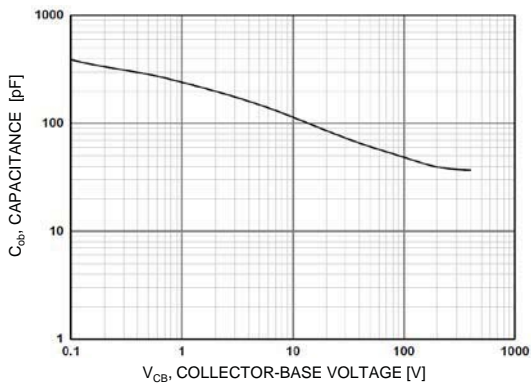

Figure 3. Collector Output Capacitance

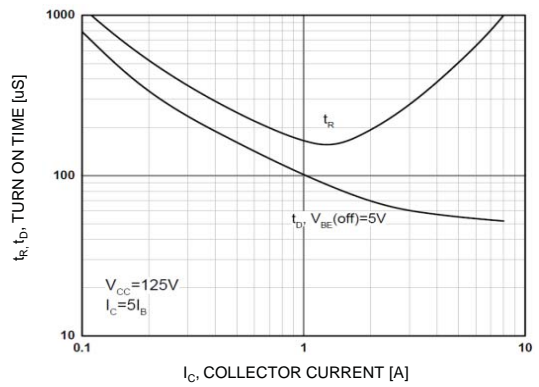

Figure 4. Turn On Time

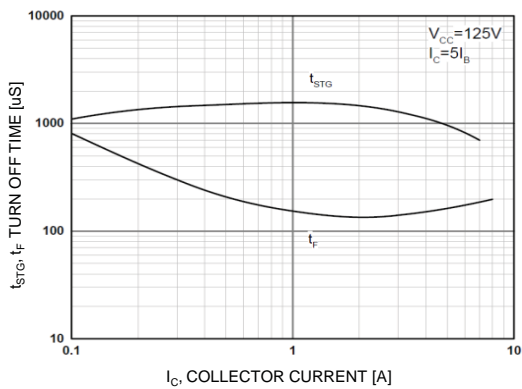

Figure 5. Turn Off Time

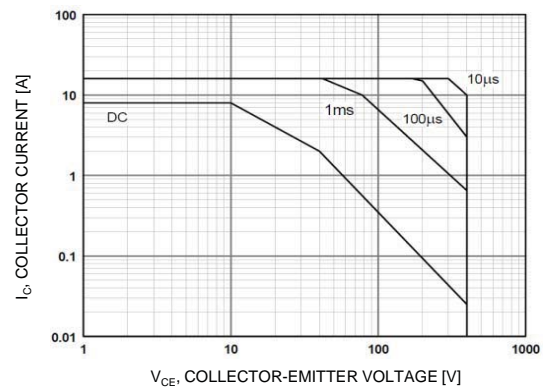

Figure 6. Safe Operating Area

Typical Characteristics

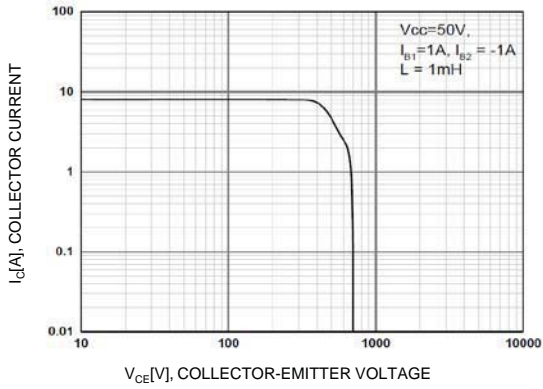

Figure 7. Reverse Biased Safe Operating Area

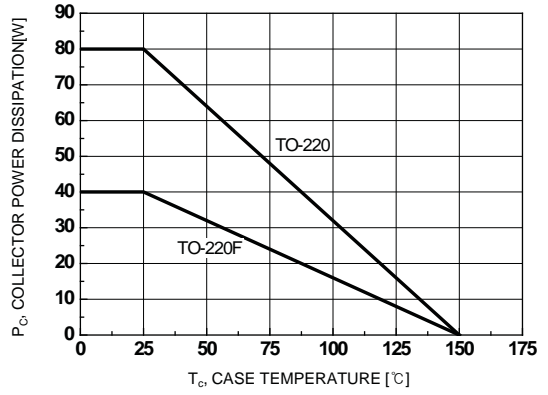
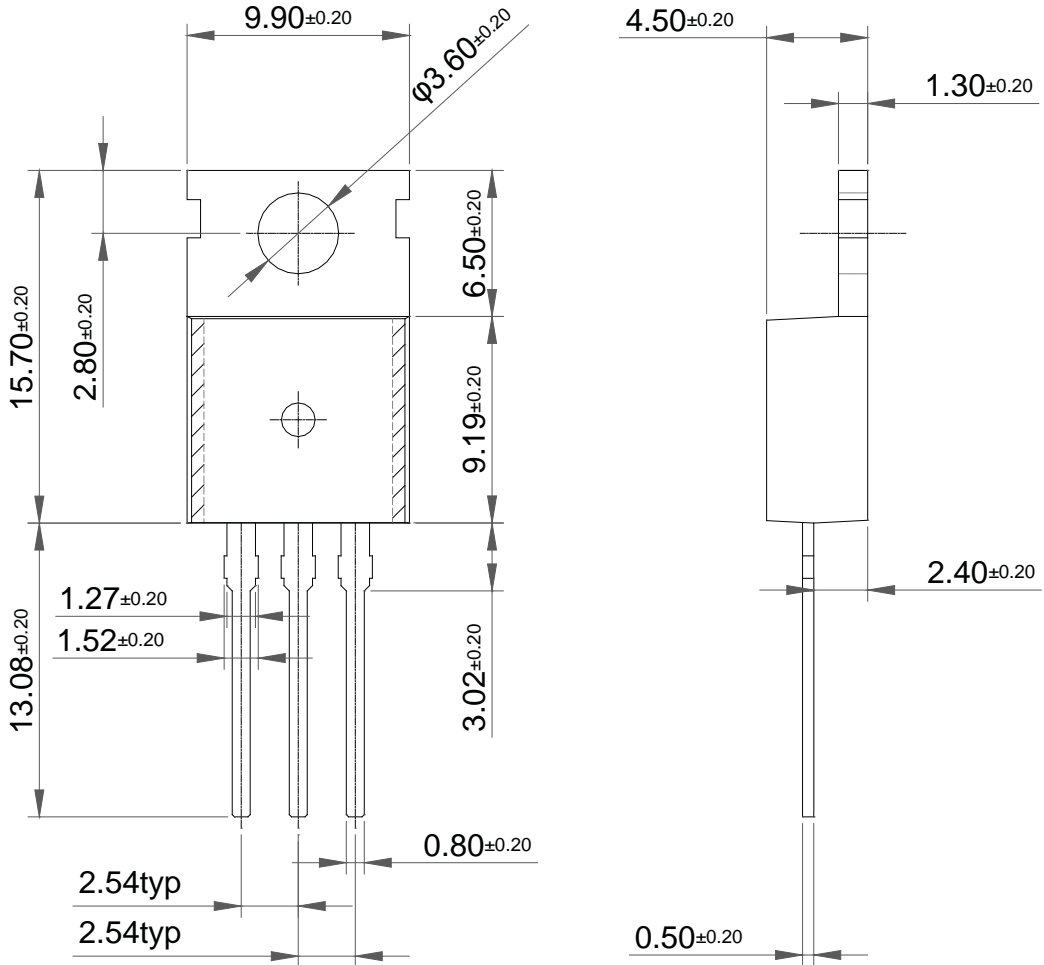

Figure 8. Power Derating

Package Dimension

TO-220 (A)



Dimensions in Millimeters

Package Dimension

TO-220 (B)

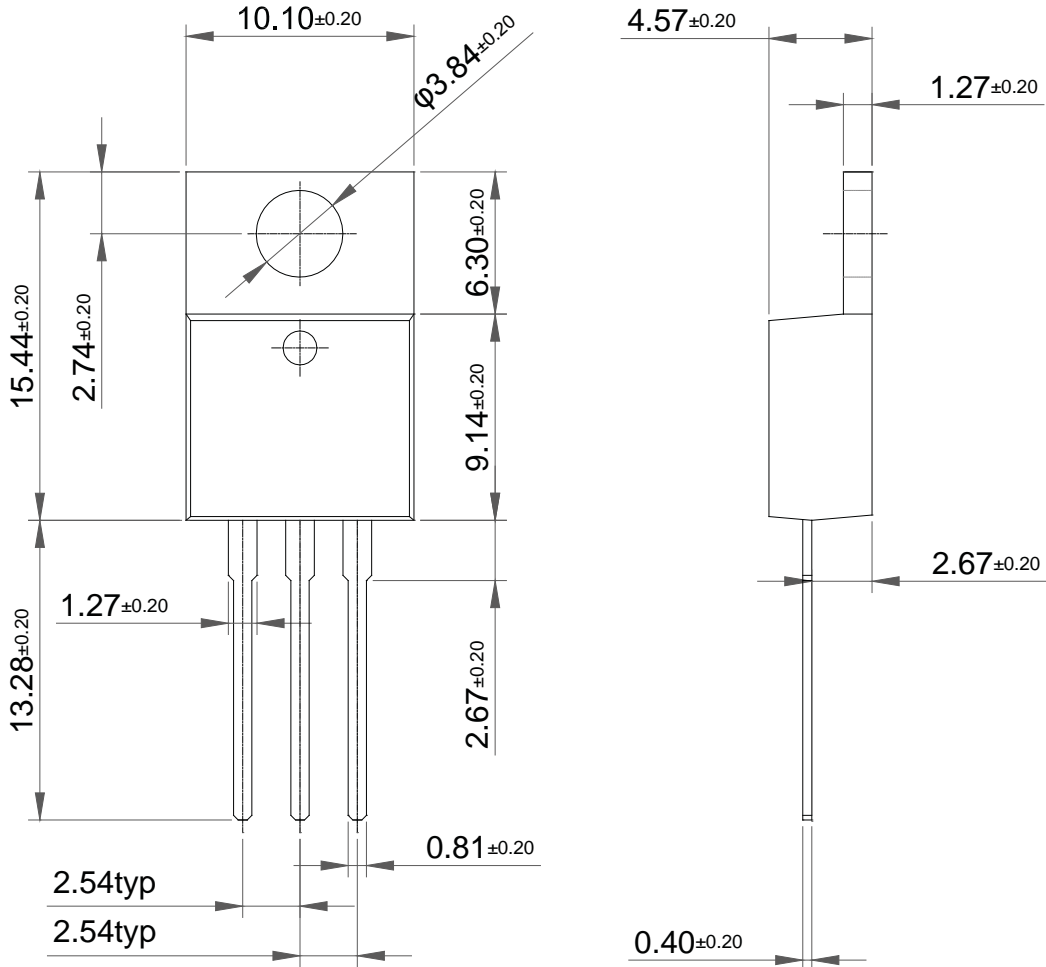

Dimensions in Millimeters

Package Dimension

TO-220F

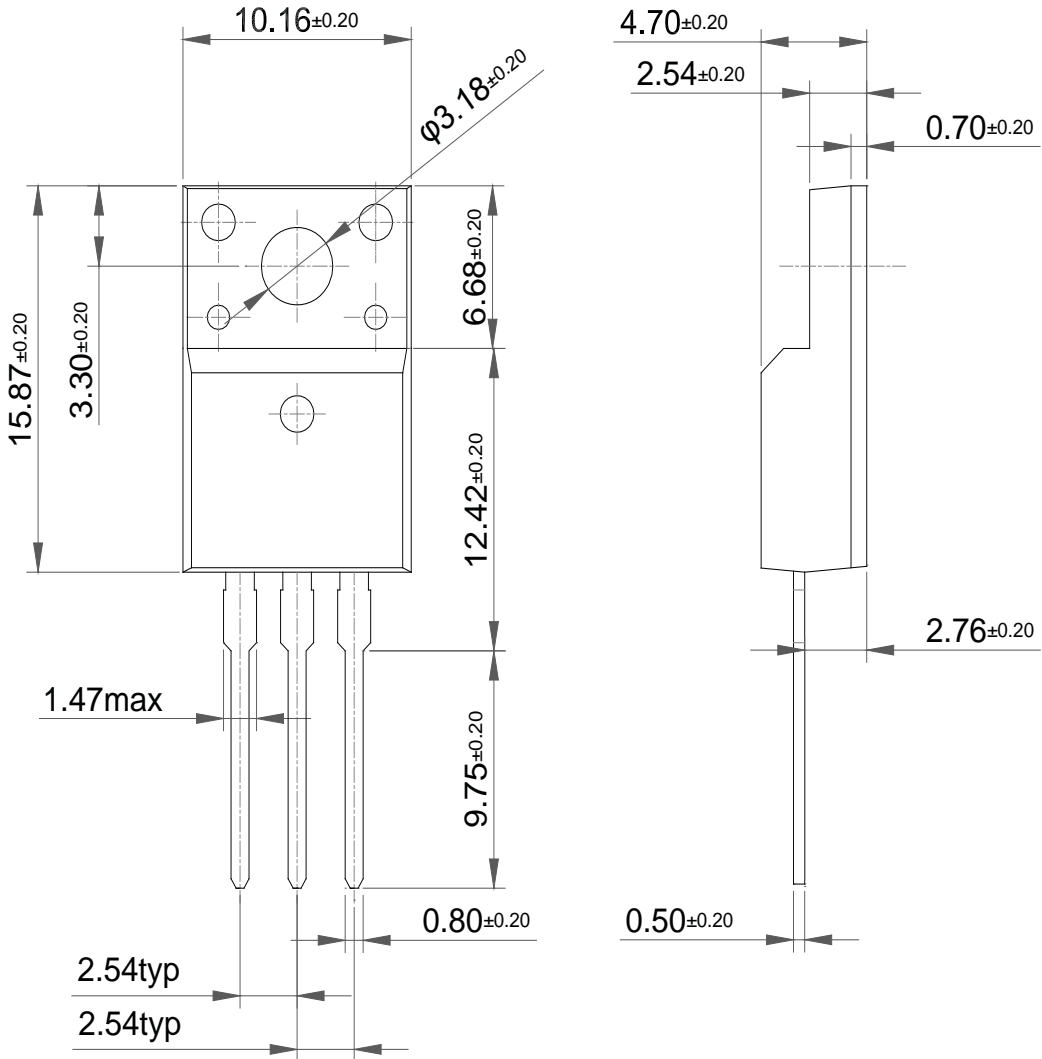

Dimensions in Millimeters