

*NPN Silicon Power Transistor, VCBO= 1050V, VCEO= 500V, IC= 2A*

## General Description

- High voltage, high speed power switching
- Suitable for switching regulator, inverters, motor controls

## Features

- VCBO = 1050V
- VCEO = 500V
- VBEO = 15V
- IC = 2A

**TO-252**



**TO-220**

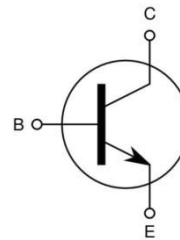
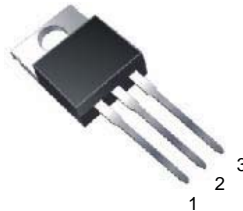

## Ordering Information

Ordering number	Package	Pin Assignment			Packing
		1	2	3	
KSD741	TO-252	B	C	E	Reel
KSP741	TO-220	B	C	E	Tube

NPN Silicon Power Transistor,  $V_{CBO}= 1050V$ ,  $V_{CEO}= 500V$ ,  $I_C= 2A$

**Absolute Maximum Ratings** TC=25°C unless otherwise noted

CHARACTERISTICS	SYMBOL	RATING		UNIT
		TO-252	TO-220	
Collector-Base Voltage	$V_{CBO}$	1050		V
Collector-Emitter Voltage	$V_{CEO}$	500		V
Emitter-Base Voltage	$V_{EBO}$	15		V
Collector Current(DC)	$I_C$	2		A
Collector Current(Pulse)	$I_{CP}$	4		A
Base Current	$I_B$	1		A
Collector Dissipation(Tc=25°C)	$P_C$	30	60	W
Junction Temperature	$T_J$	150		°C
Storage Temperature	$T_{STG}$	-65~150		°C

**Electrical Characteristics** <sup>(1)</sup> TC=25°C unless otherwise noted

CHARACTERISTICS	SYMBOL	Test Condition	Min	Typ.	Max	Unit
Collector-Base Breakdown Voltage	$V_{CBO}$	$I_C=500\mu A, I_E=0$	1050			V
Collector-Emitter Breakdown Voltage	$V_{CEO}$	$I_C=5mA, I_B=0$	500			V
Emitter-Base Breakdown Voltage	$V_{EBO}$	$I_E=1mA, I_C=0$	15	19	24	V
Emitter Cut-off Current	$I_{EBO}$	$V_{EB}=15V, I_C=0$			1	mA
DC Current Gain	$h_{FE1}$ $h_{FE2}$	$V_{CE}=5V, I_C=100mA$ $V_{CE}=3V, I_C=450mA$	48 25	70	100 50	
Collector-Emitter Saturation Voltage	$V_{CE}(sat)$	$I_C=0.7A, I_B=0.14A$ $I_C=2.0A, I_B=0.6A$			0.5 3.0	V V
Base-Emitter Saturation Voltage	$V_{BE}(sat)$	$I_C=2.0A, I_B=0.6A$			1.5	V
Output Capacitance	$C_{ob}$	$V_{CB}=10V, f=0.1MHz$		23		pF
Storage Time	$t_{stg}$	$I_C=500mA, I_B=10mA$ (UI9600)	2		6	μs

**Notes ;**

1. Pulse Test: Pulse Width≤300μs, Duty Cycle≤2%

# Typical Characteristics

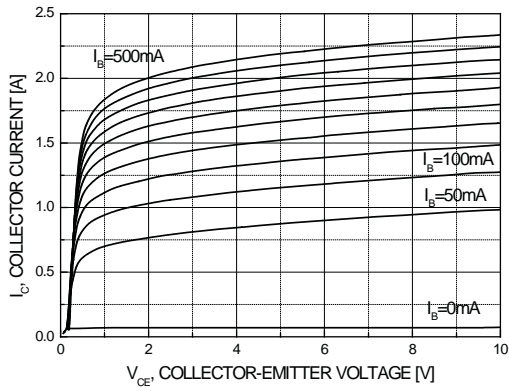

Figure 1. Static Characteristic

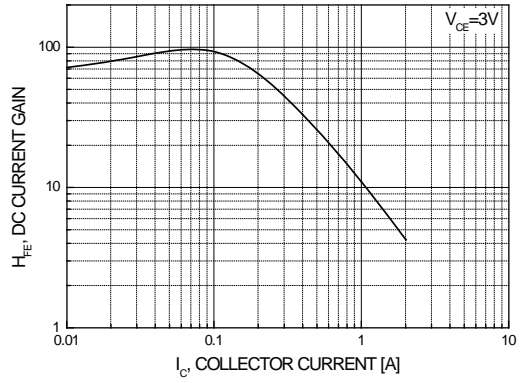

Figure 2. DC Current Gain

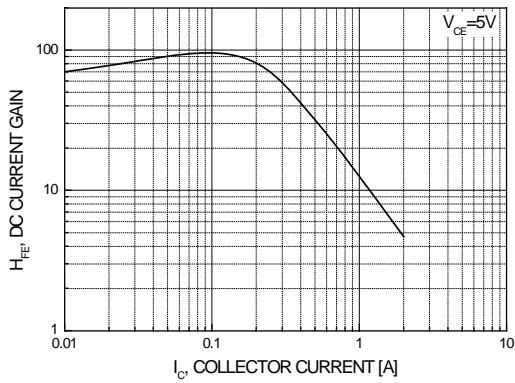

Figure 3. DC Current Gain

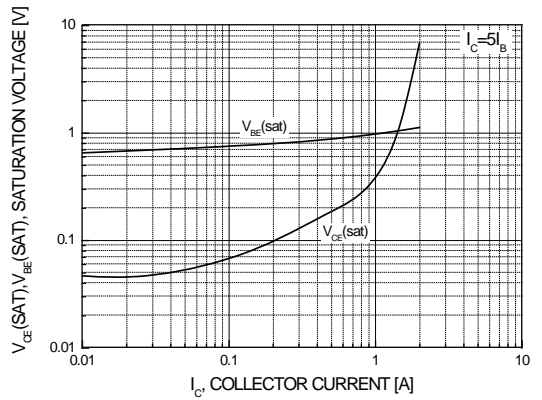

Figure 4. Saturation Voltage

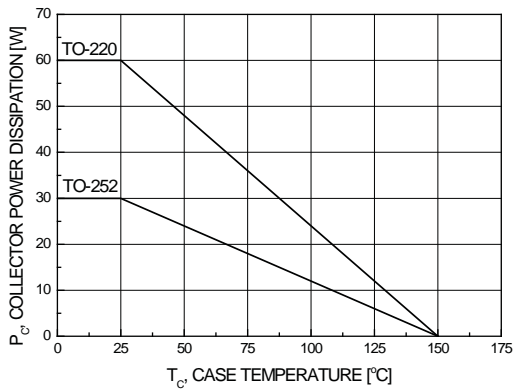
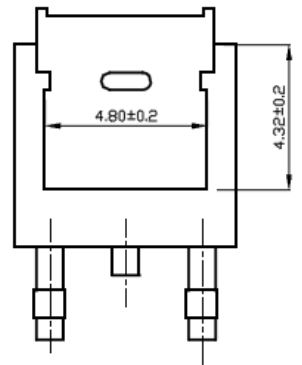
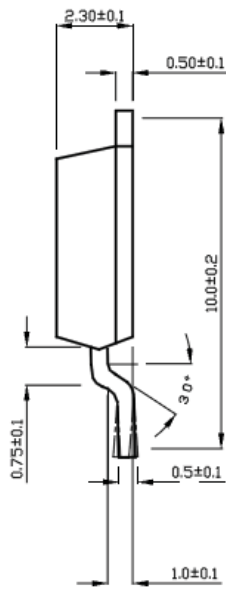
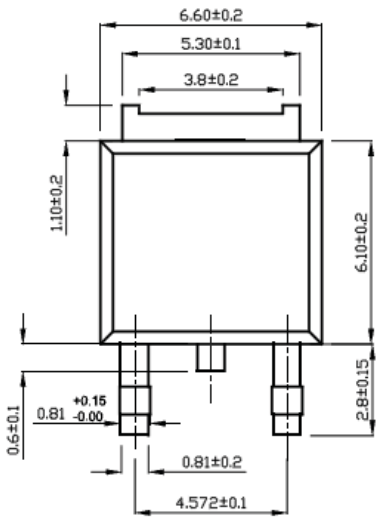

Figure 5. Power Derating

# Package Dimension

## TO-252



Package Dimension

TO-220

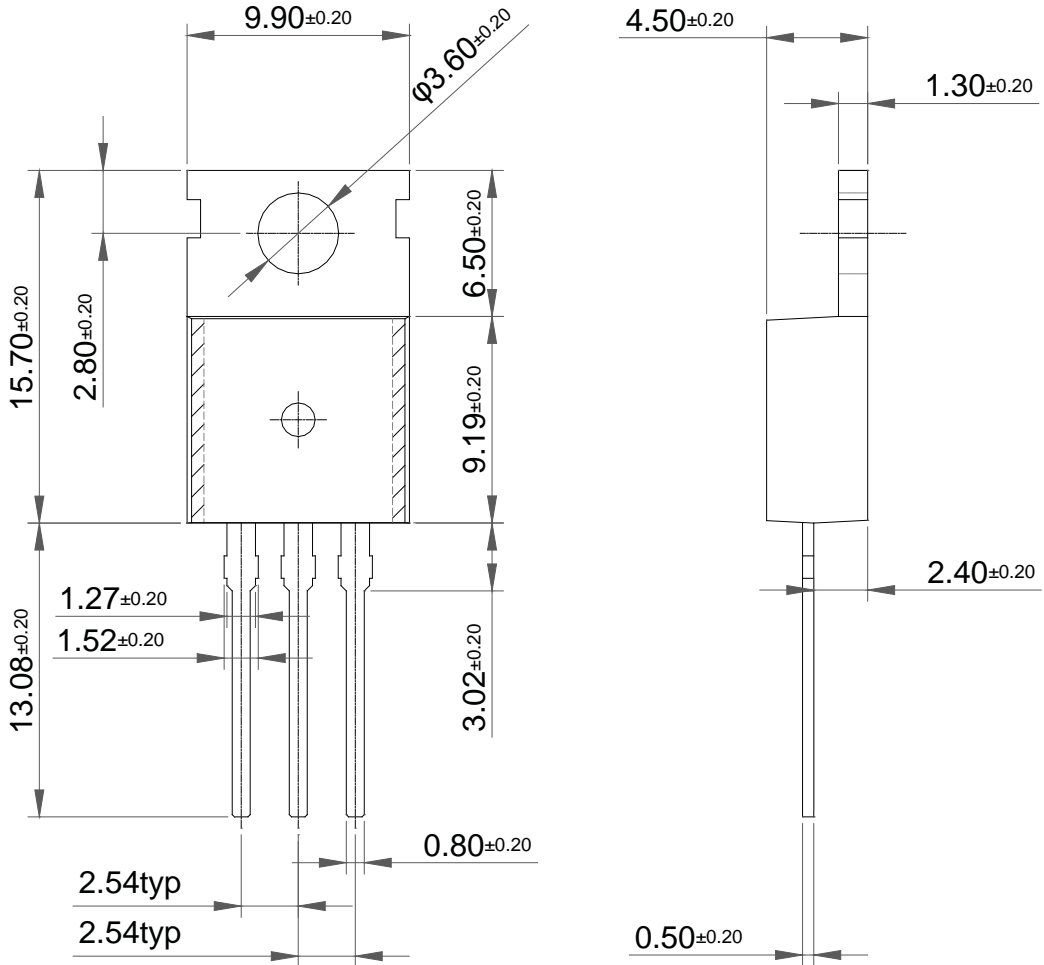

Dimensions in Millimeters