



# KSZ8441HL/FHL

---

---

## IEEE 1588v2 Precision Time Protocol-Enabled, 10/100 Mbps Ethernet End-Point Connection with 8- or 16-Bit Host Bus Interface

---

---

### Features

#### Management Capabilities

- Supports IP Header (IPv4)/TCP/UDP/ICMP Checksum Generation and Checking
- Supports IPv6 TCP/UDP/ICMP Checksum Generation and Checking
- Supports IEEE 802.3x Full-Duplex Flow Control and Half-Duplex Backpressure Collision Flow Control
- MIB Counters for Fully Compliant Statistics Gathering: 34 Counters on the Ethernet Port, Port 1
- Loopback Modes for Remote Failure Diagnostics

#### Robust Ethernet PHY Port

- Integrated IEEE 802.3/802.3u-Compliant Ethernet Transceiver Supporting 10BASE-T and 100BASE-TX
- Copper and Fiber Mode Support in the KSZ8441FHL
- Copper Mode Support in the KSZ8441HL
- Auto-Negotiation: 10/100 Mbps, Full- and Half-Duplex
- Adaptive Equalizer
- Baseline Wander Correction
- On-Chip Termination Resistors and Internal Biasing for Differential Pairs to Reduce Power
- HP Auto MDI/MDI-X Crossover Support Eliminating the Need to Differentiate between Straight or Crossover Cables in Applications

#### Ethernet MAC

- Internal Media Access Control (MAC) Unit
- 2 Kbyte Jumbo Packet Support
- MAC Filtering Function to Filter Unknown Unicast Packets
- Port 1 MAC Programmable as Either E2E or P2P Transparent Clock (TC) Port for 1588 Support

#### Comprehensive Configuration Registers Access

- Complete Register Access via the Parallel Host Interface
- Facility to Load MAC Address from EEPROM at Power-Up and Reset Time
- I/O Pin Strapping Facility to Set Certain Register Bits from I/O Pins at Reset Time
- Control Registers Configurable On-the-Fly

#### IEEE 1588v2 PTP and Clock Synchronization

- Fully Compliant with the Appropriate IEEE 1588v2 Precision Time Protocol
- One-Step or Two-Step Transparent Clock (TC) Timing Corrections
- End-to-End (E2E) or Peer-to-Peer (P2P) Transparent Clock (TC)
- Grandmaster, Master, Slave, Ordinary Clock (OC) Support
- IEEE1588v2 PTP Multicast and Unicast Frame Support
- Transports of PTP over IPv4/IPv6 UDP and IEEE 802.3 Ethernet
- Delay Request-Response and Peer Delay Mechanism
- Ingress/Egress Packet Time Stamp Capture/Recording and Checksum Update
- Correction Field Update with Residence Time and Link Delay
- IEEE1588v2 PTP Packet Filtering Unit to Reduce Host Processor Overhead
- A 64-bit Adjustable System Precision Clock
- Twelve Trigger Output Units and Twelve Time Stamp Input Units Available for Flexible IEEE1588v2 Control of Seven Programmable GPIO[6:0] Pins Synchronized to the Precision Time Clock
- GPIO Pin Usage for 1 PPS Generation, Frequency Generation, Control Bit Streams, Event Monitoring, Precision Pulse Generation, Complex Waveform Generation

#### Host Interface

- Selectable 8- or 16-bit Wide Interface
- Supports Big- and Little-Endian Processors
- Indirect Data Bus for Data, Address, and Byte Enable to Access any I/O Registers and RX/TX FIFO Buffers
- Large Internal Memory with 12 Kbyte for RX FIFO and 6 Kbytes for TX FIFO
- Programmable Low, High, and Overrun Watermark for Flow Control in RX FIFO
- Efficient Architecture Design with Configurable Host Interrupt Schemes to Minimize Host CPU Overhead and Utilization
- Queue Management Unit (QMU) Supervises Data Transfers Across This Interface

# KSZ8441HL/FHL

---

## Power and Power Management

- Single 3.3V Power Supply with Optional 1.8V, 2.5V, or 3.3V VDD I/O
- Integrated Low Voltage (~1.3V) Low-Noise Regulator (LDO) Output for Digital and Analog Core Power
- Supports IEEE P802.3az Energy Efficient Ethernet (EEE) to Reduce Power Consumption in Transceivers in LPI State
- Full-Chip Hardware or Software Power-Down (All Registers Value are Not Saved and Strap-In Value will Re-Strap After Releasing the Power-Down)
- Energy Detect Power-Down (EDPD), which Disables the PHY Transceiver when Cables are Removed
- Wake-on-LAN Supported with Magic Packet™, Link State, and Configurable Wake-Up Packet Control
- Dynamic Clock Tree Control to Reduce Clocking in Areas Not in Use
- Power Consumption Less than 0.5W

## Additional Features

- Single 25 MHz  $\pm 50$  ppm Reference Clock Requirement
- Comprehensive Programmable Two LED Indicators Support for Link, Activity, Full-/Half-Duplex, and 10/100 Speed
- LED Pins Directly Controllable
- Industrial Temperature Range:  $-40^{\circ}\text{C}$  to  $+85^{\circ}\text{C}$
- 64-Pin (10 mm x 10 mm) Lead-Free (RoHS) LQFP Package

## Applications

- Industrial Ethernet Applications that Employ IEEE 802.3-Compliant MACs. (Ethernet/IP, Profinet, MODBUS TCP, etc)
- Real-Time Ethernet Networks Requiring Sub-Microsecond Synchronization over Standard Ethernet
- IEC 61850 Networks Supporting Power Substation Automation
- Networked Measurement and Control Systems
- Industrial Automation and Motion Control Systems
- Test and Measurement Equipment

## TO OUR VALUED CUSTOMERS

It is our intention to provide our valued customers with the best documentation possible to ensure successful use of your Microchip products. To this end, we will continue to improve our publications to better suit your needs. Our publications will be refined and enhanced as new volumes and updates are introduced.

If you have any questions or comments regarding this publication, please contact the Marketing Communications Department via E-mail at [docerrors@microchip.com](mailto:docerrors@microchip.com). We welcome your feedback.

### Most Current Data Sheet

To obtain the most up-to-date version of this data sheet, please register at our Worldwide Web site at:

<http://www.microchip.com>

You can determine the version of a data sheet by examining its literature number found on the bottom outside corner of any page. The last character of the literature number is the version number, (e.g., DS30000000A is version A of document DS30000000).

### Errata

An errata sheet, describing minor operational differences from the data sheet and recommended workarounds, may exist for current devices. As device/documentation issues become known to us, we will publish an errata sheet. The errata will specify the revision of silicon and revision of document to which it applies.

To determine if an errata sheet exists for a particular device, please check with one of the following:

- Microchip's Worldwide Web site; <http://www.microchip.com>
- Your local Microchip sales office (see last page)

When contacting a sales office, please specify which device, revision of silicon and data sheet (include -literature number) you are using.

### Customer Notification System

Register on our web site at [www.microchip.com](http://www.microchip.com) to receive the most current information on all of our products.

# KSZ8441HL/FHL

---

## Table of Contents

1.0 Introduction ..... 5  
2.0 Pin Description and Configuration ..... 9  
3.0 Functional Description ..... 16  
4.0 Register Descriptions ..... 57  
5.0 Operational Characteristics ..... 155  
6.0 Electrical Characteristics ..... 156  
7.0 Timing Specifications ..... 159  
8.0 Reference Circuit: LED Strap-In Pins ..... 166  
9.0 Reference Clock: Connection and Selection ..... 167  
10.0 Selection of Isolation Transformers ..... 168  
11.0 Package Outline ..... 169  
Appendix A: Data Sheet Revision History ..... 170  
The Microchip Web Site ..... 171  
Customer Change Notification Service ..... 171  
Customer Support ..... 171  
Product Identification System ..... 172

## 1.0 INTRODUCTION

### 1.1 General Terms and Conditions

The following is list of the general terms used throughout this document:

<b>BIU - Bus Interface Unit</b>	The host interface function that performs code conversion, buffering, and the like required for communications to and from a network.
<b>BPDU - Bridge Protocol Data Unit</b>	A packet containing ports, addresses, etc. to make sure data being passed through a bridged network arrives at its proper destination.
<b>CMOS - Complementary Metal Oxide Semiconductor</b>	A common semiconductor manufacturing technique in which positive and negative types of transistors are combined to form a current gate that in turn forms an effective means of controlling electrical current through a chip.
<b>CRC - Cyclic Redundancy Check</b>	A common technique for detecting data transmission errors. CRC for Ethernet is 32 bits long.
<b>DA - Destination Address</b>	The network address to which packets are sent.
<b>DMA - Direct Memory Access</b>	A design in which memory on a chip is controlled independently of the CPU.
<b>EMI - Electromagnetic Interference</b>	A naturally occurring phenomena when the electromagnetic field of one device disrupts, impedes or degrades the electromagnetic field of another device by coming into proximity with it. In computer technology, computer devices are susceptible to EMI because electromagnetic fields are a byproduct of passing electricity through a wire. Data lines that have not been properly shielded are susceptible to data corruption by EMI.
<b>FCS - Frame Check Sequence</b>	See CRC.
<b>FID - Frame or Filter ID</b>	Specifies the frame identifier. Alternately is the filter identifier.
<b>GPIO - General Purpose Input/Output</b>	General Purpose Input/Output pins are signal pins that can be controlled or monitored by hardware and software to perform specific tasks.
<b>IGMP - Internet Group Management Protocol</b>	The protocol defined by RFC 1112 for IP multicast transmissions.
<b>IPG - Inter-Packet Gap</b>	A time delay between successive data packets mandated by the network standard for protocol reasons. In Ethernet, the medium has to be "silent" (i.e., no data transfer) for a short period of time before a node can consider the network idle and start to transmit. IPG is used to correct timing differences between a transmitter and receiver. During the IPG, no data is transferred, and information in the gap can be discarded or additions inserted without impact on data integrity.
<b>ISI - Inter-Symbol Interference</b>	The disruption of transmitted code caused by adjacent pulses affecting or interfering with each other.
<b>Jumbo Packet</b>	A packet larger than the standard Ethernet packet (1500 bytes). Large packet sizes allow for more efficient use of bandwidth, lower overhead, less processing, etc.
<b>MAC - Media Access Controller</b>	A functional block responsible for implementing the media access control layer which is a sub-layer of the data link layer.
<b>MDI - Medium Dependent Interface</b>	An Ethernet port connection that allows network hubs or switches to connect to other hubs or switches without a null-modem, or crossover, cable. MDI provides the standard interface to a particular media (copper or fiber) and is therefore "media dependent".

# KSZ8441HL/FHL

---

**MDI-X - Medium Dependent Interface Crossover**

An Ethernet port connection that allows networked end stations (i.e., PCs or workstations) to connect to each other using a null-modem, or crossover, cable. For 10/100 full-duplex networks, an end point (such as a computer) and a switch are wired so that each transmitter connects to the far end receiver. When connecting two computers together, a cable that crosses the TX and RX is required to do this. With auto MDI-X, the PHY senses the correct TX and RX roles, eliminating any cable confusion.

**MIB - Management Information Base**

The MIB comprises the management portion of network devices. This can include things like monitoring traffic levels and faults (statistical), and can also change operating parameters in network nodes (static forwarding addresses).

**MII - Media Independent Interface**

The MII accesses PHY registers as defined in the IEEE 802.3 specification.

**NIC - Network Interface Card**

An expansion board inserted into a computer to allow it to be connected to a network. Most NICs are designed for a particular type of network, protocol, and media, although some can serve multiple networks.

**NRZ - Non-Return to Zero**

A type of signal data encoding whereby the signal does not return to a zero state in between bits.

**PHY - Physical Interface Device**

A device or functional block which performs the physical layer interface function in a network.

**PLL - Phase-Locked Loop**

An electronic circuit that controls an oscillator so that it maintains a constant phase angle (i.e., lock) on the frequency of an input, or reference, signal. A PLL ensures that a communication signal is locked on a specific frequency and can also be used to generate, modulate, and demodulate a signal and divide a frequency.

**PME - Power Management Event**

An occurrence that affects the directing of power to different components of a system.

**PTP - Precision Time Protocol**

A protocol, IEEE 1588 as applied to this device, for synchronizing the clocks of devices attached to a specific network.

**QMU - Queue Management Unit**

Manages packet traffic between MAC/PHY interface and the system host. The QMU has built-in packet memories for receive and transmit functions called TXQ (Transmit Queue) and RXQ (Receive Queue).

**SA - Source Address**

The address from which information has been sent.

**TDR - Time Domain Reflectometry**

TDR is used to pinpoint flaws and problems in underground and aerial wire, cabling, and fiber optics. They send a signal down the conductor and measure the time it takes for the signal, or part of the signal, to return.

**TSU - Time Stamp Input Unit**

The functional block which captures signals on the GPIO pins and assigns a time to the specific event.

**TOU - Trigger Output Unit**

The functional block which generates user configured waveforms on a specified GPIO pin at a specific trigger time.

**UTP - Unshielded Twisted Pair**

Commonly a cable containing four twisted pairs of wires. The wires are twisted in such a manner as to cancel electrical interference generated in each wire, therefore shielding is not required.

## 1.2 General Description

The KSZ8441 product is an IEEE 1588v2-enabled Ethernet controller device with an internal MAC and PHY that provides integrated communication and synchronization for a range of industrial Ethernet applications.

The KSZ8441 product enables end-point connection in a centralized topology.

A flexible 8- or 16-bit general bus interface is provided for interfacing to an external host processor.

The KSZ8441 devices incorporate the IEEE 1588v2 protocol. Sub-microsecond synchronization is available via the use of hardware-based time stamping and transparent clocks making it the ideal solution for time-synchronized layer 2 communication in critical industrial applications.

Extensive general purpose input/output (GPIO) capabilities are available to use with the IEEE 1588v2 PTP to efficiently and accurately interface to locally-connected devices.

Complementing the industry's most integrated IEEE 1588v2 device is a precision timing protocol (PTP) v2 software stack that has been pre-qualified with the KSZ84xx product family. The PTP stack has been optimized around the KSZ84xx chip architecture, and is available in source code format along with Microchip's chip driver.

The KSZ8441 is built upon Microchip's industry-leading Ethernet technology, with features designed to offload host processing and streamline overall design, including:

- One integrated 10/100BASE-TX PHY transceiver, featuring the industry's lowest power consumption
- Flexible management options that support common standard interfaces

A robust assortment of power management features including Energy Efficient Ethernet (EEE) have been designed in to satisfy energy efficient environments.

**FIGURE 1-1: KSZ8441 TOP LEVEL ARCHITECTURE**

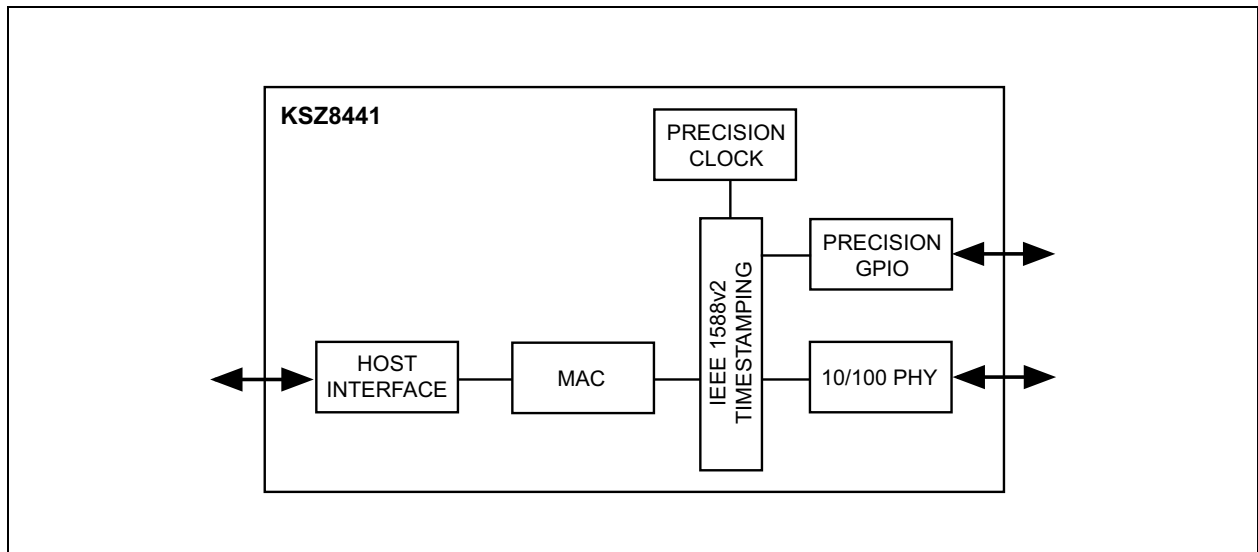

# KSZ8441HL/FHL

FIGURE 1-2: SYSTEM BLOCK DIAGRAM, KSZ8441HL/FHL

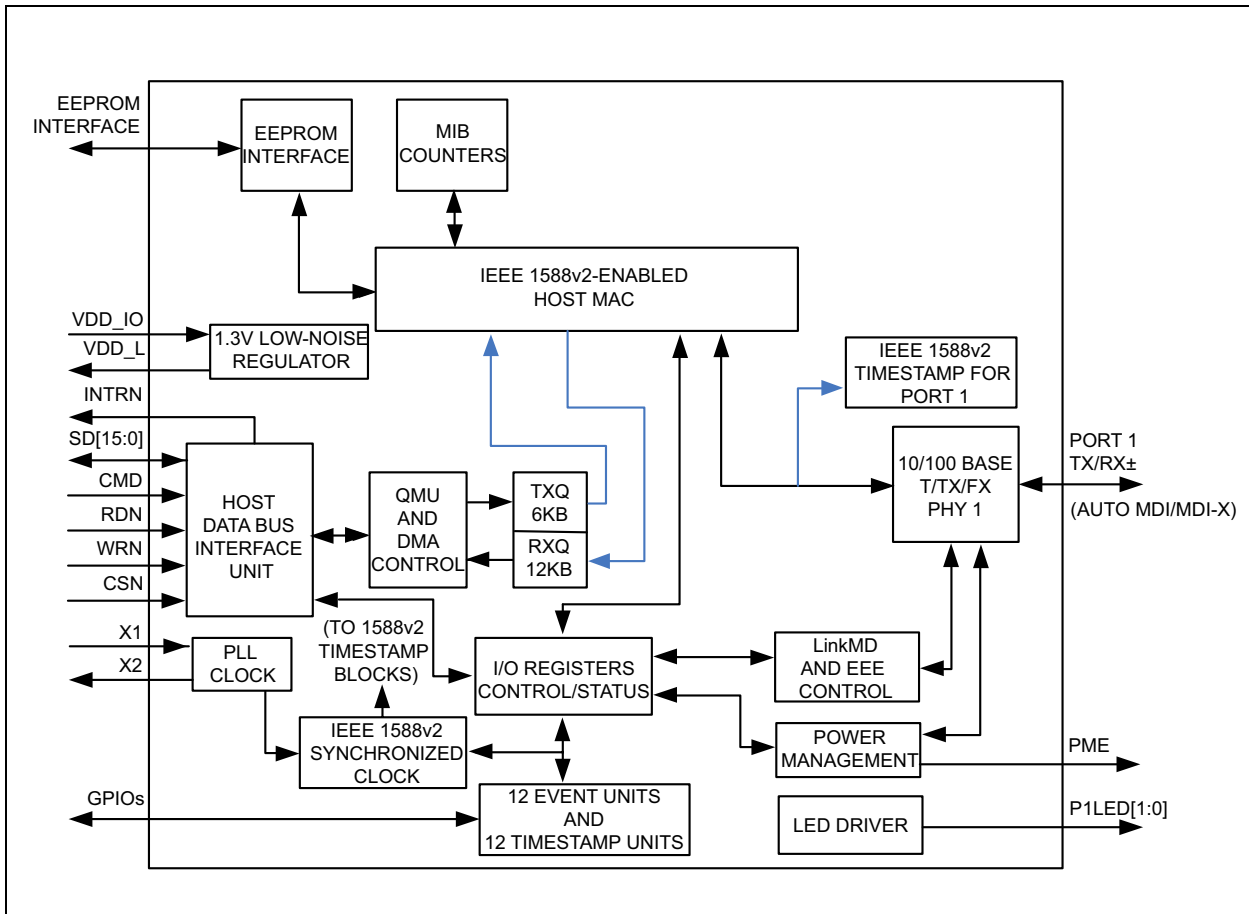



## 2.0 PIN DESCRIPTION AND CONFIGURATION

FIGURE 2-1: 64-PIN LQFP ASSIGNMENT, (TOP VIEW)

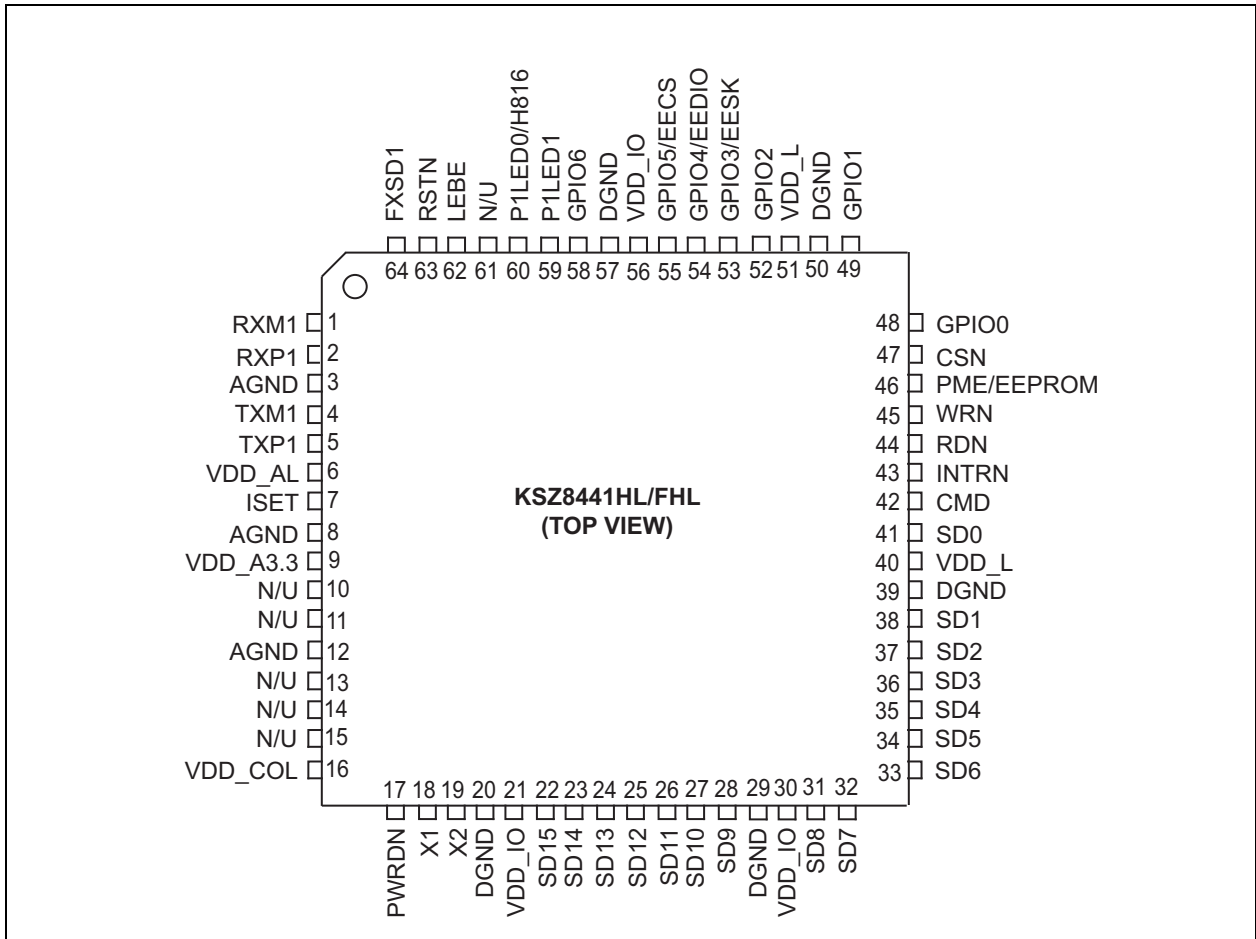

# KSZ8441HL/FHL

TABLE 2-1: SIGNALS FOR KSZ8441HL/FHL

Pin Number	Pin Name	Type (Note 2-1)	Description
1	RXM1	I/O	Port 1 physical receive (MDI) or transmit (MDIX) signal (– differential).
2	RXP1	I/O	Port 1 physical receive (MDI) or transmit (MDIX) signal (+ differential).
3	AGND	GND	Analog Ground.
4	TXM1	I/O	Port 1 physical transmit (MDI) or receive (MDIX) signal (– differential).
5	TXP1	I/O	Port 1 physical transmit (MDI) or receive (MDIX) signal (+ differential).
6	VDD_AL	P	This pin is used as an input for the low-voltage analog power. Its source should have appropriate filtering with a ferrite bead and capacitors.
7	ISET	O	Set physical transmits output current. Pull-down this pin with a 6.49 k $\Omega$ (1%) resistor to ground.
8	AGND	GND	Analog Ground.
9	VDD_A3.3	P	3.3V analog V <sub>DD</sub> input power supply (Must be well decoupled).
10	N/U	I/O	Not used. Do not connect anything to this pin.
11	N/U	I/O	Not used. Do not connect anything to this pin.
12	AGND	GND	Analog Ground.
13	N/U	I/O	Not used. Do not connect anything to this pin.
14	N/U	I/O	Not used. Do not connect anything to this pin.
15	N/U	I	This unused input should be connected to GND.
16	VDD_COL	P	This pin is an input for the low-voltage analog power. Its source should have appropriate filtering with a ferrite bead and capacitors.
17	PWRDN	IPU	<b>Full-Chip Power-Down</b> Active-Low (Low = Power-down; High or floating = Normal operation). While this pin is asserted low, all I/O pins will be tri-stated. All registers will be set to their default state. While this pin is asserted, power consumption will be minimal. When the pin is de-asserted, power consumption will climb to nominal and the device will be in the same state as having been reset by the reset pin (RSTN, pin 63).
18	X1	I	<b>25 MHz Crystal or Oscillator Clock Connection</b> Pins (X1, X2) connect to a crystal or frequency oscillator source. If an oscillator is used, X1 connects to a V <sub>DD_IO</sub> voltage tolerant oscillator and X2 is a no connect. This clock requirement is $\pm 50$ ppm.
19	X2	O	
20	DGND	GND	Digital ground.
21	VDD_IO	P	3.3V, 2.5V, or 1.8V digital V <sub>DD</sub> input power pin for IO logic and the internal low-voltage regulator.
22	SD15/BE3	I/O (PD)	Shared Data Bus Bit[15] or BE3: This is data bit (D15) access when CMD = “0”. This is Byte Enable 3 (BE3, 4th byte enable and active-high) at double-word boundary access in 16-bit bus mode when CMD = “1”. This pin must be tied to GND in 8-bit bus mode.

**TABLE 2-1: SIGNALS FOR KSZ8441HL/FHL (CONTINUED)**

Pin Number	Pin Name	Type (Note 2-1)	Description
23	SD14/BE2	I/O (PD)	Shared Data Bus Bit[14] or BE2: This is data bit (D14) access when CMD = "0". This is Byte Enable 2 (BE2, 3rd byte enable and active-high) at double-word boundary access in 16-bit bus mode when CMD = "1". This pin must be tied to GND in 8-bit bus mode.
24	SD13/BE1	I/O (PD)	Shared Data Bus Bit[13] or BE1: This is data bit (D13) access when CMD = "0". This is Byte Enable 1 (BE1, 2nd byte enable and active-high) at double-word boundary access in 16-bit bus mode when CMD = "1". This pin must be tied to GND in 8-bit bus mode.
25	SD12/BE0	I/O (PD)	Shared Data Bus Bit[12] or BE0: This is data bit (D12) access when CMD = "0". This is Byte Enable 0 (BE0, 1st byte enable and active-high) at double-word boundary access in 16-bit bus mode when CMD = "1". This pin must be tied to GND in 8-bit bus mode.
26	SD11	I/O (PD)	Shared Data Bus Bit[11]: This is data bit (D11) access when CMD = "0". Don't care when CMD = "1". This pin must be tied to GND in 8-bit bus mode.
27	SD10/A10	I/O (PD)	Shared Data Bus bit[10]: This is data bit (D10) access when CMD = "0". In 8-bit bus mode, this pin must be tied to GND. In 16-bit bus mode, this is address A10 access when CMD = "1".
28	SD9/A9	I/O (PD)	Shared Data Bus Bit[9] or A9: This is data bit (D9) access when CMD = "0". In 8-bit bus mode, this pin must be tied to GND. In 16-bit bus mode, this is address A9 access when CMD = "1".
29	DGND	GND	Digital Ground.
30	VDD_IO	P	3.3V, 2.5V, or 1.8V digital V <sub>DD</sub> input power pin for IO logic and the internal low-voltage regulator.
31	SD8/A8	IPU/O	Shared Data Bus Bit[8] or A8: This is data bit (D8) access when CMD = "0". In 8-bit bus mode, this pin must be tied to GND. In 16-bit bus mode, this is address A8 access when CMD = "1".
32	SD7/A7	IPD/O	Shared Data Bus Bit[7] or A7: This is data bit (D7) access when CMD = "0". In 8-bit bus mode, this is address A7 (1st write) or Don't care (2nd write) access when CMD = "1". In 16-bit bus mode, this is address A7 access when CMD = "1".
33	SD6/A6	IPU/O	Shared Data Bus Bit[6] or A6: This is data bit (D6) access when CMD = "0". In 8-bit bus mode, this is address A6 (1st write) or Don't care (2nd write) access when CMD = "1". In 16-bit bus mode, this is address A6 access when CMD = "1".
34	SD5/A5	IPU/O	Shared Data Bus Bit[5] or A5: This is data bit (D5) access when CMD = "0". In 8-bit bus mode, this is address A5 (1st write) or Don't care (2nd write) access when CMD = "1". In 16-bit bus mode, this is address A5 access when CMD = "1".
35	SD4/A4	IPD/O	Shared Data Bus Bit[4] or A4: This is data bit (D4) access when CMD = "0". In 8-bit bus mode, this is address A4 (1st write) or Don't care (2nd write) access when CMD = "1". In 16-bit bus mode, this is address A4 access when CMD = "1".

# KSZ8441HL/FHL

TABLE 2-1: SIGNALS FOR KSZ8441HL/FHL (CONTINUED)

Pin Number	Pin Name	Type (Note 2-1)	Description
36	SD3/A3	I/O (PD)	Shared Data Bus Bit[3] or A3: This is data bit (D3) access when CMD = "0". In 8-bit bus mode, this is address A3 (1st write) or Don't care (2nd write) access when CMD = "1". In 16-bit bus mode, this is address A3 access when CMD = "1".
37	SD2/A2	I/O (PD)	Shared Data Bus Bit[2] or A2: This is data bit (D2) access when CMD = "0". In 8-bit bus mode, this is address A2 (1st write) or A10 (2nd write) access when CMD = "1". In 16-bit bus mode, this is address A2 access when CMD = "1".
38	SD1/A1/A9	I/O (PD)	Shared Data Bus Bit[1] or A1 or A9: This is data bit (D1) access when CMD = "0". In 8-bit bus mode, this is address A1 (1st write) or A9 (2nd write) access when CMD = "1". In 16-bit bus mode, this is "Don't care" when CMD = "1".
39	DGND	GND	Digital Ground
40	VDD_L	P	This pin can be used in two ways: as the pin to input a low voltage to the device if the internal low-voltage regulator is not used, or as the low-voltage output if the internal low-voltage regulator is used.
41	SD0/A0/A8	I/PU/O	Shared Data Bus Bit[0] or A0 or A8: This is data bit (D0) access when CMD = "0". In 8-bit bus mode, this is address A0 (1st write) or A8 (2nd write) access when CMD = "1". In 16-bit bus mode, this is "Don't care" when CMD = "1".
42	CMD	IPD	<b>Command Type:</b> This command input decides the SD[15:0] shared data bus access information. When command input is low, the access of shared data bus is for data access either SD[15:0] -> DATA[15:0] in 16-bit bus mode or SD[7:0] -> DATA[7:0] in 8-bit bus mode. <b>When command input is high, in 16-bit bus mode:</b> The access of shared data bus is for address A[10:2] access at shared data bus SD[10:2] and SD[1:0] is "don't care." Byte enable BE[3:0] at SD[15:12] and the SD[11] is "don't care". <b>in 8-bit bus mode:</b> It is for address A[7:0] during 1st write access at shared data bus SD[7:0] or A[10:8] during 2nd write access at shared data bus SD[2:0] (SD[7:3] is don't care).
43	INTRN	OPU	<b>Interrupt Output.</b> This is an active-low signal going to the host CPU to indicate an interrupt status bit is set. This pin needs an external 4.7 kΩ pull-up resistor.
44	RDN	IPU	<b>Read Strobe</b> This signal is an active-low signal used as the asynchronous read strobe during read access cycles by the Host processor. It is recommended that it be pulled up with a 4.7 kΩ resistor.
45	WRN	IPU	<b>Write Strobe</b> This is an asynchronous write strobe signal used during write cycles from the external host processor. It is a low active signal.
46	PME/EEPROM	IPD/O	<b>Power Management Event:</b> This output signal indicates that a wake-on-LAN event has been detected. The KSZ8441 is requesting that the system wake up from low power mode. Its assertion polarity is programmable with the default polarity to be active-low. <b>Config Mode: (EEPROM):</b> At the end of the power-up/reset period, this pin is sampled and the pull-up/pull-down value is latched. The value latched will indicate if a serial EEPROM is present or not. See <a href="#">Table 2-2</a> for details.

**TABLE 2-1: SIGNALS FOR KSZ8441HL/FHL (CONTINUED)**

Pin Number	Pin Name	Type (Note 2-1)	Description
47	CSN	IPU	<b>Chip Select:</b> This signal is the chip-select signal that is used by the external Host processor for accesses to the device. It is an active-low signal.
48	GPIO0	I/O (PU)	<b>General Purpose Input/Output [0]</b> This pin can be used as an input or output pin for use by the IEEE 1588 event trigger or time stamp capture units. It will be synchronized to the internal IEEE 1588 clock. The host processor can also directly drive or read this GPIO pin.
49	GPIO1	I/O (PU)	This pin is GPIO1 (refer to GPIO0 pin 48 description).
50	DGND	GND	Digital Ground.
51	VDD_L	P	This pin can be used in two ways: as the pin to input a low voltage to the device if the internal low-voltage regulator is not used, or as the low-voltage output if the internal low-voltage regulator is used.
52	GPIO2	I/O (PU)	This pin is GPIO2 (refer to GPIO0 pin 48 description).
53	GPIO3/EESK	I/O (PD)	<b>Default function:</b> EEPROM Serial Clock Output: A serial output clock is used to load configuration data into the KSZ8441 from the external EEPROM when it is present. <b>Alternate function:</b> General Purpose Input/Output [3]: This pin can be used as an input or output pin for use by the IEEE 1588 event trigger or time stamp capture units. It will be synchronized to the internal IEEE 1588 clock. The host processor can also directly drive or read this GPIO pin. Function of this pin is controlled by bit[5] in IOMUXSEL register.
54	GPIO4/EEDIO	I/O (PD)	<b>Default function:</b> EEPROM Data Input/Output: Serial data input/output is from/to external EEPROM when it is present. <b>Alternate function:</b> General Purpose Input/Output [4]: This pin can be used as an input or output pin for use by the IEEE 1588 event trigger or time stamp capture units. It will be synchronized to the internal IEEE 1588 clock. The host processor can also directly drive or read this GPIO pin. Function of this pin is controlled by bit[2] in IOMUXSEL register.
55	GPIO5/EECS	I/O (PD)	<b>Default function:</b> EEPROM Chip Select Output: This signal is used to select an external EEPROM device when it is present. <b>Alternate function:</b> General Purpose Input/Output [5]: This pin can be used as an input or output pin for use by the IEEE 1588 event trigger or time stamp capture units. It will be synchronized to the internal IEEE 1588 clock. The host processor can also directly drive or read this GPIO pin. Function of this pin is controlled by bit[1] in IOMUXSEL register.
56	VDD_IO	P	3.3V, 2.5V, or 1.8V digital V <sub>DD</sub> input power pin for IO logic and the internal low-voltage regulator.
57	DGND	GND	Digital ground.

# KSZ8441HL/FHL

**TABLE 2-1: SIGNALS FOR KSZ8441HL/FHL (CONTINUED)**

Pin Number	Pin Name	Type (Note 2-1)	Description																				
58	GPIO6	I/O (PU)	This pin is GPIO6 (refer to GPIO0 pin 48 description).																				
59	P1LED1	IPU/O	<p><b>Programmable LED Output to Indicate Port 1 Activity/Status.</b>            The LED is ON (active) when output is LOW; the LED is OFF (inactive) when output is HIGH. The output on the LED pins is determined by the table below if Reg. 0x06C – 0x06D, bits[14:12] are set to '000'. Otherwise, the LED pins are controlled via the processor by setting Reg. 0x06C – 0x06D, bits[14:12] to a non-zero value.            Automatic port 1 indicators are defined as follows:</p> <table border="1"> <thead> <tr> <th></th> <th colspan="4">Two bits [9:8] in SSCR7 Control Register</th> </tr> <tr> <th>—</th> <th>00 (default)</th> <th>01</th> <th>10</th> <th>11</th> </tr> </thead> <tbody> <tr> <td>P1LED1</td> <td>Speed</td> <td>ACT</td> <td>Duplex</td> <td>Duplex</td> </tr> <tr> <td>P1LED0</td> <td>Link/ACT</td> <td>Link</td> <td>Link/ACT</td> <td>Link</td> </tr> </tbody> </table>		Two bits [9:8] in SSCR7 Control Register				—	00 (default)	01	10	11	P1LED1	Speed	ACT	Duplex	Duplex	P1LED0	Link/ACT	Link	Link/ACT	Link
	Two bits [9:8] in SSCR7 Control Register																						
—	00 (default)	01	10	11																			
P1LED1	Speed	ACT	Duplex	Duplex																			
P1LED0	Link/ACT	Link	Link/ACT	Link																			
60	P1LED0/ H816	IPU/O	<p>Link = LED ON; ACT = LED Blink; Link/ACT = LED ON/Blink            Speed = LED ON (100BASE-TX); LED OFF (10BASE-T)            Duplex = LED ON (Full-Duplex); LED OFF (Half-Duplex)</p> <p>Config Mode: (P1LED1): At the end of the power-up/reset period, this pin is sampled and the pull-up/pull-down value is latched. It must be at a logic high level at this time. See <a href="#">Table 2-2</a> for details.</p> <p>Config Mode: (P1LED0/H816): At the end of the power-up/reset period, this pin is sampled and the pull-up/pull-down value is latched. The value latched will determine if 8-bit or 16-bit mode will be used for the Host Interface. See <a href="#">Table 2-2</a> for details.</p>																				
61	N/U	O	This unused output will always be driven low while the device is powered on.																				
62	LEBE	IPU/O	<p>During normal operation, this unused output drives low            Config Mode: (LEBE)            At the end of the power-up/reset period, this pin is sampled and the pull-up/pull-down value is latched. The value latched will determine if “Little Endian” or “Big Endian” mode will be used for the Host Interface. See <a href="#">Table 2-2</a> for details.</p>																				
63	RSTN	IPU	Hardware reset input (active-low). This reset input is required to be low for a minimum of 10 ms after supply voltages VDD_IO and 3.3V are stable.																				
64	FXSD1	I	<p>Fiber Signal Detect input for port 1 in 100BASE-FX fiber mode. When in copper mode, this input is unused and should be pulled to GND.            Note: This functionality is available only on the KSZ8441FHL device.</p>																				

**Note 2-1** P = power supply; GND = ground; N/U = not used  
 I = input; O = output; I/O = bi-directional; NC = no connect  
 IPU/O = Input with internal pull-up (58 kΩ ±30%) during power-up/reset; output pin otherwise.  
 IPD/O = Input with internal pull-down (58 kΩ ±30%) during power-up/reset; output pin otherwise.  
 IPU = Input with internal pull-up. (58 kΩ ±30%)  
 IPD = Input with internal pull-down. (58 kΩ ±30%)  
 OPU = Output with internal pull-up. (58 kΩ ±30%)  
 OPD = Output with internal pull-down. (58 kΩ ±30%)

I/O (PD) = Bi-directional input/output with internal pull-down. (58 kΩ ±30%)

I/O (PU) = Bi-directional input/output with internal pull-up. (58 kΩ ±30%)

**TABLE 2-2: STRAPPING OPTIONS**

Pin Number	Pin Name	Type <a href="#">Note 2-1</a>	Description
46	PME/ EEPROM	IPD/O	<b>EEPROM Select During Power-Up/Reset</b> Pull-Up = EEPROM present NC or Pull-Down (default) = EEPROM not present. This pin value is latched into register CCR, bit [9] at the end of the power-on-reset time.
59	P1LED1	IPU/O	<b>Reserved</b> NC or Pull-Up (default) = Normal Operation Pull-Down = Reserved
60	P1LED0/ H816	IPU/O	<b>8- or 16-Bit Bus Mode Select During Power-Up/Reset</b> NC or Pull-Up (default) = 16-bit bus mode, Pull-Down = 8-bit bus mode. This pin value is also latched into register CCR, bit [7:6] at the end of the power-on-reset time.
62	P2LED0/ LEBE	IPU/O	<b>Endian Mode Select During Power-Up/Reset</b> NC or Pull-Up (default) = Little Endian Pull-Down = Big Endian. This pin value is latched into register CCR, bit [10] at the end of the power-on-reset time. Note that this pin will be driven low at all times other than when it is interrogated at strap-in time.

**Note 2-1** IPU/O = Input with internal pull-up (58 kΩ ±30%) during power-up/reset; output pin otherwise.  
IPD/O = Input with internal pull-down (58 kΩ ±30%) during power-up/reset; output pin otherwise.

All strapping pins are latched at the end of the power-up or reset cycle. They are also latched when powering-up from a hardware or software power-down or hardware reset state.

# KSZ8441HL/FHL

---

## 3.0 FUNCTIONAL DESCRIPTION

The KSZ8441 is a highly integrated endpoint networking device that incorporates a 10BASE-T/100BASE-TX physical layer transceiver (PHY), an associated MAC unit, a Bus Interface Unit (BIU) with one general 8-/16-bit Host Interface, and key IEEE 1588 Precision Time Protocol (PTP) features.

The KSZ8441 operates in a managed mode. In managed mode, a host processor can access and control all PHY, MAC, and IEEE 1588 related registers within the device via the Host Interface.

Physical signal transmission and reception are enhanced through the use of analog circuits in the PHY that make the design more efficient and allow for low power consumption. Both power management and Energy Efficient Ethernet (EEE) are designed to save more power while device is in the idle state. Wake-on-LAN is implemented to allow the KSZ8441 to monitor the network for packets intended to wake up the system which is upstream from the KSZ8441.

The KSZ8441 is fully compliant to IEEE802.3u standards.

### 3.1 Physical (PHY) Block

#### 3.1.1 100BASE-TX TRANSMIT

The 100BASE-TX transmit function performs parallel-to-serial conversion, 4B/5B coding, scrambling, NRZ-to-NRZI conversion, and MLT3 encoding and transmission.

The circuitry starts with a parallel-to-serial conversion, which converts the MII data from the MAC into a 125 MHz serial bit stream. The data and control stream is then converted into 4B/5B coding, followed by a scrambler. The serialized data is further converted from NRZ-to-NRZI format, and then transmitted in MLT3 current output. An external 6.49 k $\Omega$  (1%) resistor for the 1:1 transformer ratio sets the output current.

The output signal has a typical rise/fall time of 4 ns and complies with the ANSI TP-PMD standard regarding amplitude balance, overshoot, and timing jitter. The wave-shaped 10BASE-T output driver is also incorporated into the 100BASE-TX driver.

#### 3.1.2 100BASE-TX RECEIVE

The 100BASE-TX receiver function performs adaptive equalization, DC restoration, MLT3-to-NRZI conversion, data and clock recovery, NRZI-to-NRZ conversion, de-scrambling, 4B/5B decoding, and serial-to-parallel conversion.

The receiving side starts with the equalization filter to compensate for inter-symbol interference (ISI) over the twisted pair cable. Because the amplitude loss and phase distortion is a function of the cable length, the equalizer has to adjust its characteristics to optimize performance. In this design, the variable equalizer makes an initial estimation based on comparisons of incoming signal strength against some known cable characteristics, and then tunes itself for optimization. This is an ongoing process and self-adjusts against environmental changes such as temperature variations.

Next, the equalized signal goes through a DC restoration and data conversion block. The DC restoration circuit is used to compensate for the effect of baseline wander and to improve the dynamic range. The differential data conversion circuit converts the MLT3 format back to NRZI. The slicing threshold is also adaptive.

The clock recovery circuit extracts the 125 MHz clock from the edges of the NRZI signal. This recovered clock is then used to convert the NRZI signal into the NRZ format. This signal is sent through the de-scrambler followed by the 4B/5B decoder. Finally, the NRZ serial data is converted to an MII format and provided as the input data to the MAC.

#### 3.1.3 SCRAMBLER/DE-SCRAMBLER (100BASE-TX ONLY)

The purpose of the scrambler is to spread the power spectrum of the signal to reduce electromagnetic interference (EMI) and baseline wander.

Transmitted data is scrambled through the use of an 11-bit wide linear feedback shift register (LFSR). The scrambler generates a 2047-bit non-repetitive sequence. Then the receiver de-scrambles the incoming data stream using the same sequence as at the transmitter.

#### 3.1.4 PLL CLOCK SYNTHESIZER (RECOVERY)

The internal PLL clock synthesizer generates various internal clocks for the KSZ8441 system timing from an external 25 MHz crystal or oscillator. Refer to the [Device Clocks](#) section for details of this area.



## 3.1.5 100BASE-FX OPERATION

Fiber Mode is available only on the KSZ8441FHL device.

100BASE-FX operation (fiber mode) is similar to 100BASE-TX operation except that the scrambler/de-scrambler and MLT3 encoder/decoder are bypassed on transmission and reception. In this fiber mode, the auto-negotiation feature is bypassed and auto MDI/MDIX is disabled because there is no standard that supports fiber auto-negotiation and auto MDI/MDIX mode. The fiber port must be forced to either full-duplex or half-duplex mode.

All KSZ8441 devices are in copper mode (10BASE-T/100BASE-TX) when reset or powered on. Fiber mode is enabled by clearing bit [6] in the CFGR register (0x0D8-0x0D9). Bit [13] in the DSP\_CNTRL\_6 register (0x734-0x735) should also be cleared when the port is set to fiber mode.

## 3.1.6 100BASE-FX SIGNAL DETECTION

In 100BASE-FX operation, the fiber signal detect input FXSD1 is usually connected to the signal detect (SD) output pin of the fiber transceiver. When FXSD is low, no fiber signal is detected and a far-end fault (FEF) is generated. When FXSD is high, the fiber signal is detected. To ensure proper operation, a resistive voltage divider is recommended to adjust the fiber transceiver SD output voltage swing to match the FXSD pin's input voltage threshold.

Alternatively, the user may choose not to implement the FEF feature. In this case, the FXSD input pin is tied high to force 100BASE-FX mode.

In copper mode, and on the KSZ8441HL, FXSD1 is unused and should be pulled low.

## 3.1.7 100BASE-FX FAR-END FAULT

A Far-End Fault (FEF) occurs when the signal detection is logically false on the receive side of the fiber transceiver. The KSZ8441FHL detects an FEF condition when its FXSD input is below the fiber signal detect threshold. When an FEF condition is detected, the KSZ8441FHL signals its fiber link partner that an FEF condition has occurred by sending 84 1's followed by a zero in the idle period between frames. By default, FEF is enabled. FEF can be disabled through a register setting in P1CR4[12].

## 3.1.8 10BASE-T TRANSMIT

The 10BASE-T driver is incorporated with the 100BASE-TX driver to allow for transmission using the same magnetics. They are internally wave-shaped and pre-emphasized into outputs with typical 2.3V amplitude. The harmonic contents are at least 27 dB below the fundamental frequency when driven by an all-ones Manchester-encoded signal.

## 3.1.9 10BASE-T RECEIVE

On the receive side, input buffers and level detecting squelch circuits are employed. A differential input receiver circuit and a phase-locked loop (PLL) perform the decoding function.

The Manchester-encoded data stream is separated into clock signal and NRZ data. A squelch circuit rejects signals with levels less than 400 mV or with short pulse widths to prevent noise at the RXP1 or RXM1 input from falsely triggering the decoder. When the input exceeds the squelch limit, the PLL locks onto the incoming signal and the KSZ8441 decodes a data frame. The receiver clock is maintained active during idle periods in between data reception.

## 3.1.10 MDI/MDI-X AUTO CROSSOVER

To eliminate the need for crossover cables between similar devices, the KSZ8441 supports HP Auto MDI/MDI-X and IEEE 802.3u standard MDI/MDI-X auto crossover. HP Auto MDI/MDI-X is the default.

The auto-sense function detects remote transmit and receive pairs and correctly assigns the transmit and receive pairs for the KSZ8441. This feature is extremely useful when end users are unaware of cable types in addition to saving on an additional uplink configuration connection. The auto-crossover feature can be disabled through the port control registers. The IEEE 802.3u standard MDI and MDI-X definitions are in [Table 3-1](#).

# KSZ8441HL/FHL

**TABLE 3-1: MDI/MDI-X PIN DEFINITION**

MDI		MDI-X	
RJ-45 Pin	Signal	RJ-45 Pin	Signal
1	TD+	1	RD+
2	TD-	2	RD-
3	RD+	3	TD+
6	RD-	6	TD-

### 3.1.10.1 Straight Cable

A straight cable connects an MDI device to an MDI-X device, or an MDI-X device to an MDI device. [Figure 3-1](#) depicts a typical straight cable connection between a network interface card (NIC) and a switch, or hub (MDI-X).

**FIGURE 3-1: TYPICAL STRAIGHT CABLE CONNECTION**

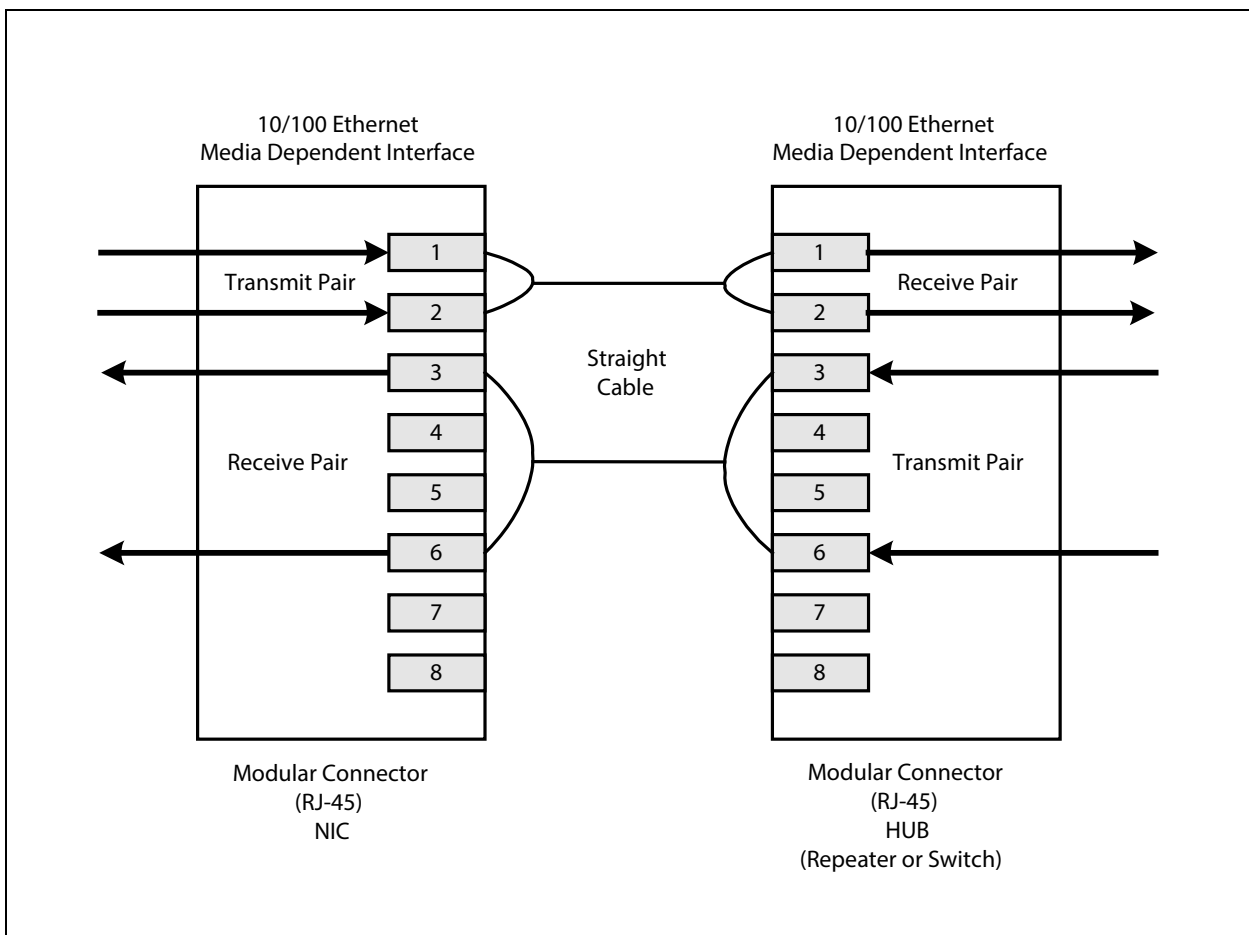

## 3.1.10.2 Crossover Cable

A crossover cable connects an MDI device to another MDI device, or an MDI-X device to another MDI-X device. Figure 3-2 shows a typical crossover cable connection between two chips or hubs (two MDI-X devices).

**FIGURE 3-2: TYPICAL CROSSOVER CABLE CONNECTION**

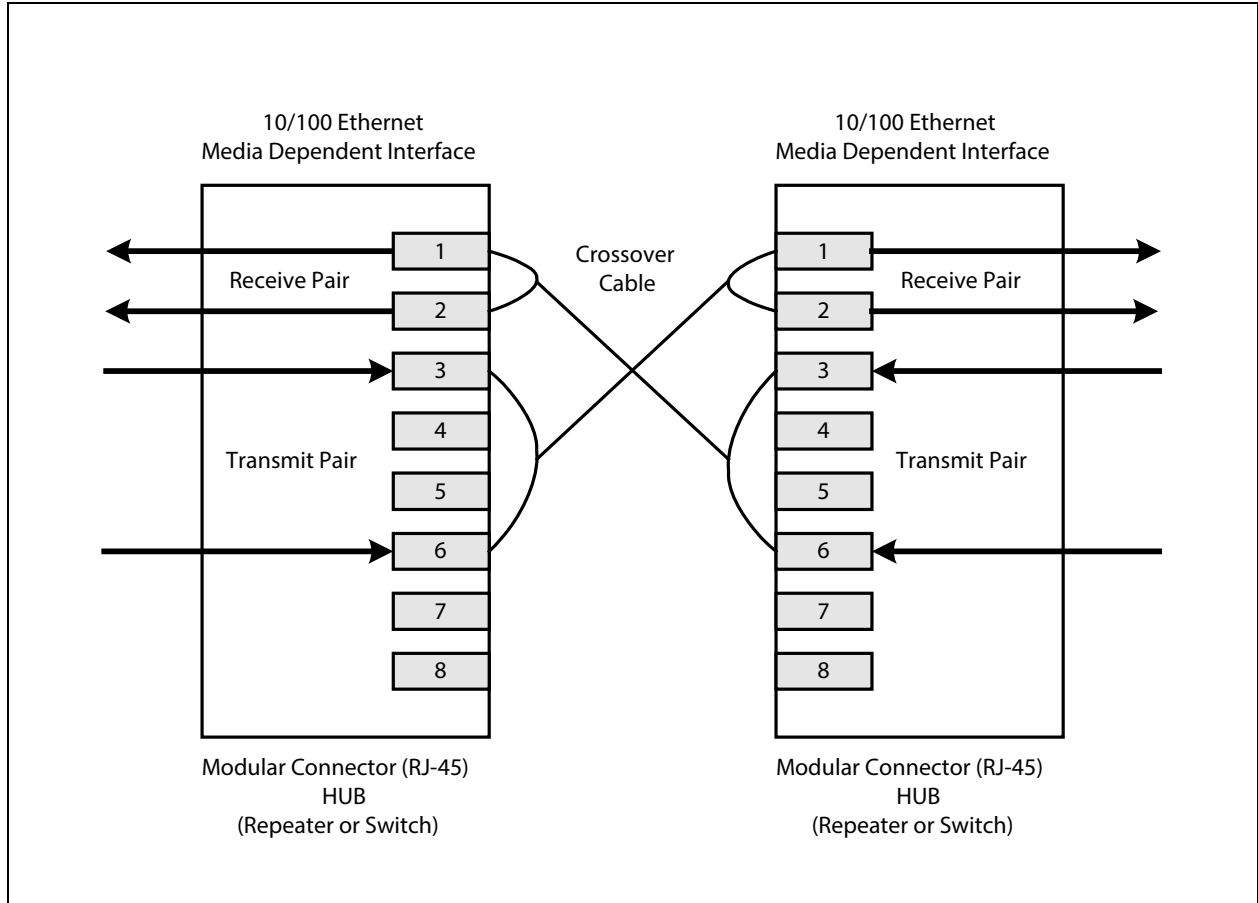

## 3.1.11 AUTO-NEGOTIATION

It allows the port to operate at either 10BASE-T or 100BASE-TX. Auto-negotiation allows unshielded twisted pair (UTP) link partners to select the best common mode of operation. In auto-negotiation, the link partners advertise capabilities across the link to each other and then compare their own capabilities with those they received from their link partners. The highest speed and duplex setting that is common to the two link partners is selected as the mode of operation. Auto-negotiation is also used to negotiate support for Energy Efficient Ethernet (EEE). Auto-negotiation takes place only across a copper link and not a fiber link.

The following list shows the speed and duplex operation mode from highest to lowest.

- Priority 1: 100BASE-TX, full-duplex
- Priority 2: 100BASE-TX, half-duplex
- Priority 3: 10BASE-T, full-duplex
- Priority 4: 10BASE-T, half-duplex

If auto-negotiation is not supported or the link partner to the KSZ8441 is forced to bypass auto-negotiation, the mode is automatically set by observing the signal at the receiver. This is known as parallel mode because while the transmitter is sending auto-negotiation advertisements, the receiver is listening for advertisements or a fixed signal protocol.

The auto-negotiation link up process is shown in the following flow chart.

# KSZ8441HL/FHL

FIGURE 3-3: AUTO-NEGOTIATION FLOW CHART

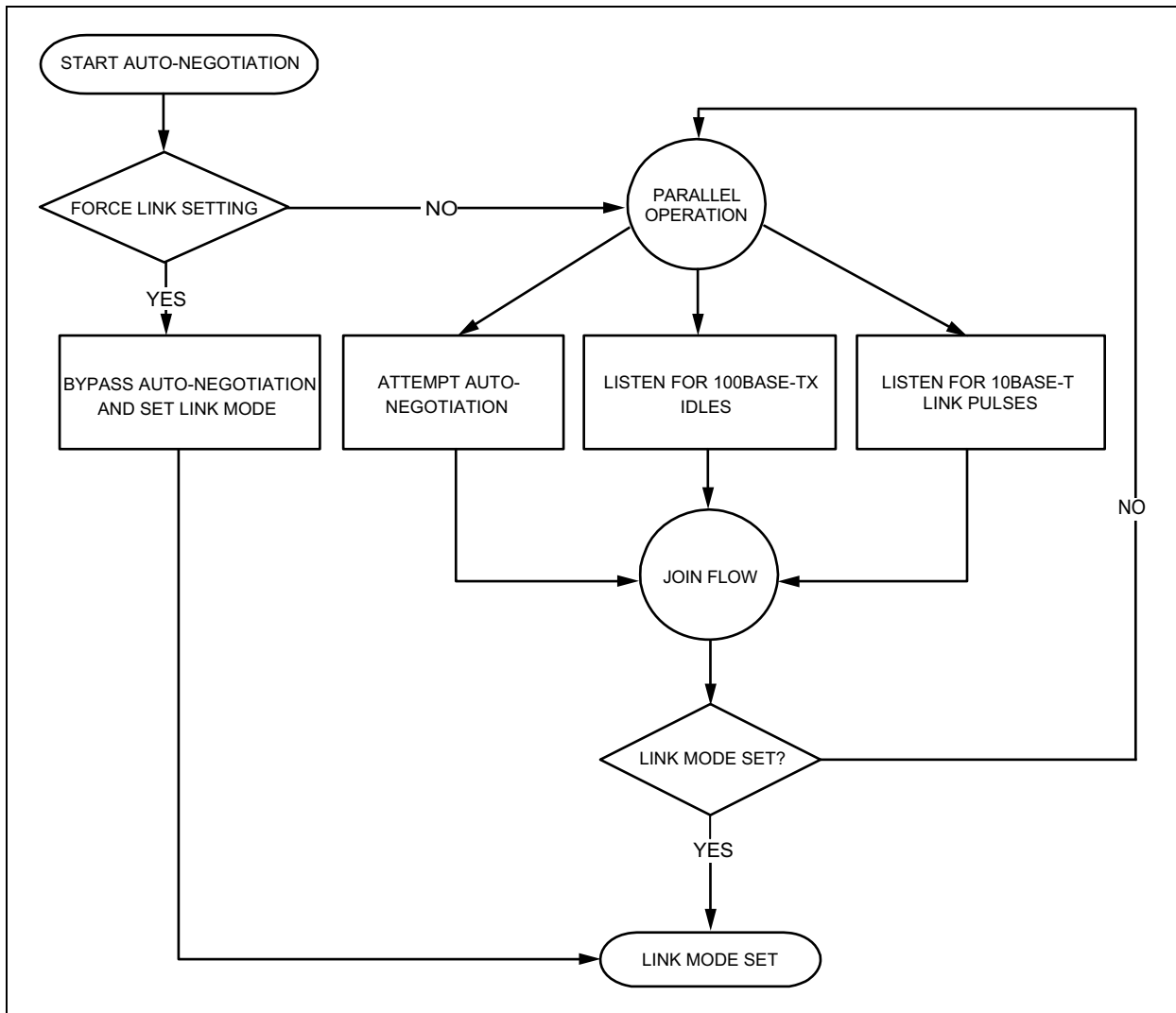

## 3.1.12 LINKMD<sup>®</sup> CABLE DIAGNOSTICS

The KSZ8441 LinkMD uses time domain reflectometry (TDR) to analyze the cabling plant for common cabling problems such as open circuits, short circuits, and impedance mismatches.

LinkMD works by sending a pulse of known amplitude and duration down the MDI and MDI-X pairs and then analyzes the shape of the reflected signal. Timing the pulse duration gives an indication of the distance to the cabling fault with a maximum distance of 200m and an accuracy of  $\pm 2$ m. Internal circuitry displays the TDR information in a user-readable digital format in register P1SCSLMD[8:0].

Cable diagnostics are only valid for copper connections. Fiber-optic operation is not supported.

### 3.1.12.1 Access

LinkMD is initiated by accessing register P1SCSLMD (0x07C), the PHY special control/status and LinkMD register.

### 3.1.12.2 Usage

Before initiating LinkMD, the value 0x8008 must be written to the ANA\_CNTRL\_3 Register (0x74C – 0x74D). This needs to be done once (after power-on reset), but does not need to be repeated for each initiation of LinkMD. Auto-MDIX must also be disabled before using LinkMD. To disable Auto-MDIX, write a '1' to P1CR4[10] or P2CR4[10] to enable manual control over the pair used to transmit the LinkMD pulse. The self-clearing cable diagnostic test enable bit, P1SCSLMD[12] or P2SCSLMD[12], is set to '1' to start the test on this pair.

When bit P1SCSLMD[12] returns to '0', the test is completed. The test result is returned in bits P1SCSLMD[14:13] or P2SCSLMD[14:13] and the distance is returned in bits P1SCSLMD[8:0]. The cable diagnostic test results are as follows:

- 00 = Valid test, normal condition
- 01 = Valid test, open circuit in cable
- 10 = Valid test, short-circuit in cable
- 11 = Invalid test, LinkMD<sup>®</sup> failed

If P1SCSLMD[14:13] is "11", this indicates an invalid test. This occurs when the KSZ8441 is unable to shut down the link partner. In this instance, the test is not run, because it is not possible for the KSZ8441 to determine if the detected signal is a reflection of the signal generated or a signal from another source.

Cable distance can be approximated by utilizing the following formula:

- $P1SCSLMD[8:0] \times 0.4m$  for port 1 cable distance

This constant (0.4m) may be calibrated for different cabling conditions, including cables with a velocity of propagation that varies significantly from the norm.

### 3.1.13 ON-CHIP TERMINATION RESISTORS

Using the KSZ8441 reduces board cost and simplifies board layout by using on-chip termination resistors for the RX/TX differential pairs, eliminating the need for external termination resistors in copper mode. The internal chip termination and biasing provides significant power savings when compared with using external biasing and termination resistors.

### 3.1.14 LOOPBACK SUPPORT

The KSZ8441 provides two loopback modes. One is near-end (remote) loopback to support remote diagnosing of failures on line side, and the other is far-end loopback to support local diagnosing of failures through all blocks of the device. In loopback mode, the speed of the PHY port will be set to 100BASE-TX full-duplex mode.

#### 3.1.14.1 Far-End Loopback

Far-end (Local) loopback is accomplished by sending and receiving data at the host interface. The loopback path starts at the host port's transmit inputs (TX data), wraps around at the Port 1 PHY, and ends at the host port's receive outputs (RX data). Bit [8] of the P1CR4 register (0x07E) or bit [14] of P1MBCR (0x04C) is used to enable the far-end loopback. The far-end loopback path is illustrated in [Figure 3-4](#).

#### 3.1.14.2 Near-End (Remote) Loopback

Near-end (Remote) loopback is conducted at the Port 1 PHY. The loopback path starts at the PHY receive inputs (RXP1/RXM1), wraps around at the PHY PMD/PMA (Physical Media Dependent/Physical Media Attachment) block, and ends at the PHY port's transmit outputs (TXP1/TXM1). Bit[1] of register P1PHYCTRL is used to enable near-end loopback. As an alternative, Bit[9] of register P1SCSLMD can be used to enable near-end loopback. The near-end loopback path is illustrated in [Figure 3-4](#).

# KSZ8441HL/FHL

FIGURE 3-4: NEAR-END AND FAR-END LOOPBACK

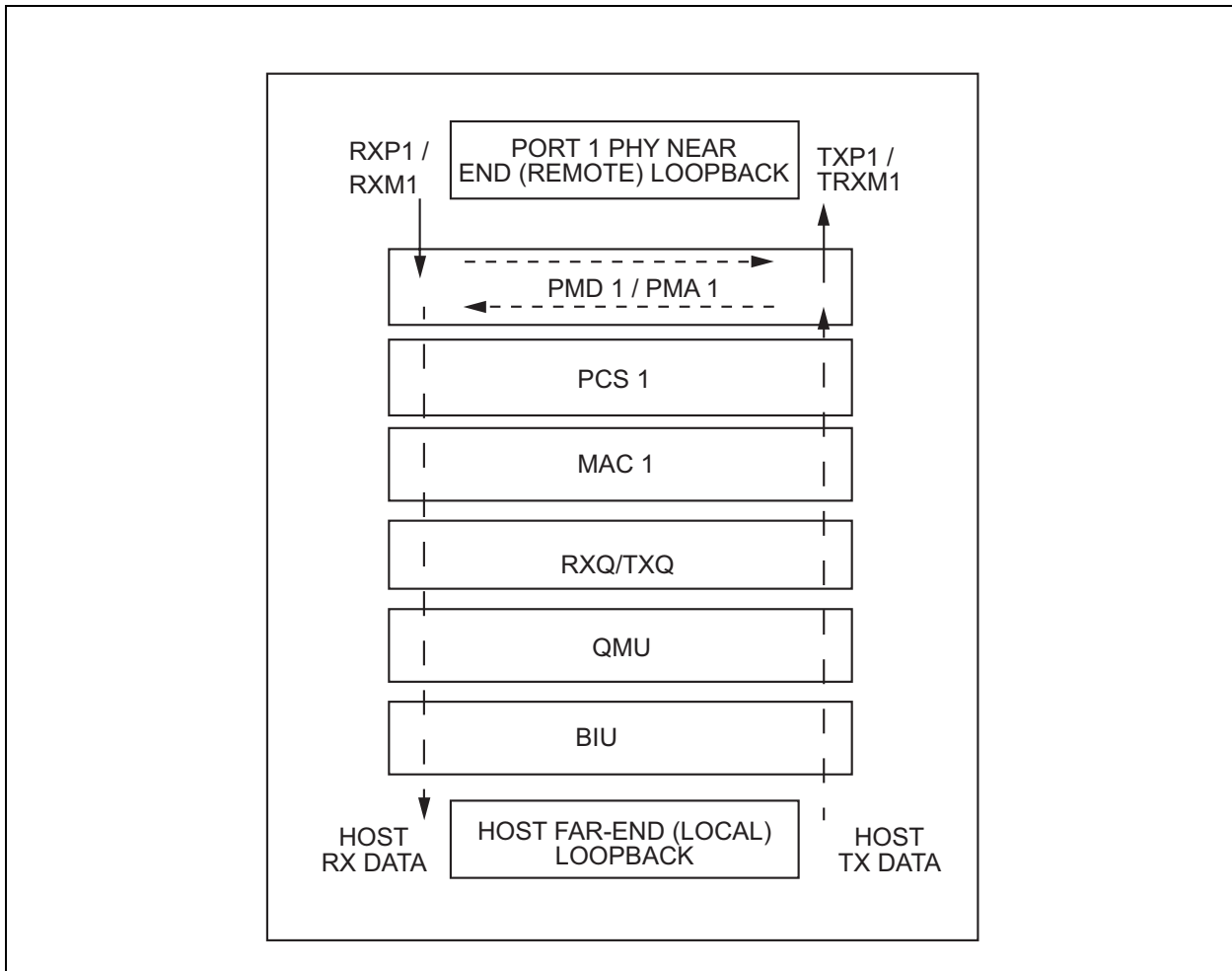

## 3.2 Media Access Controller (MAC) Block

### 3.2.1 MAC OPERATION

The KSZ8441 strictly abides by IEEE 802.3 standards to maximize compatibility.

### 3.2.2 INTER-PACKET GAP (IPG)

If a frame is successfully transmitted, then the minimum 96-bit time for IPG is measured between two consecutive packets. If the current packet is experiencing collisions, the minimum 96-bit time for IPG is measured from carrier sense (CRS) to the next transmit packet.

### 3.2.3 BACK-OFF ALGORITHM

The KSZ8441 implements the IEEE standard 802.3 binary exponential back-off algorithm in half-duplex mode. After 16 collisions, the packet is dropped.

### 3.2.4 LATE COLLISION

If a transmit packet experiences collisions after 512 bit times of the transmission, the packet is dropped.

### 3.2.5 LEGAL PACKET SIZE

The KSZ8441 discards packets less than 64 bytes and can be programmed to accept packet sizes up to 1536 bytes in SGCR2[1]. The KSZ8441 can also be programmed for special applications to accept packet sizes up to 2000 bytes in SGCR1[4].

## 3.2.6 FLOW CONTROL

The KSZ8441 supports standard 802.3x flow control frames in both transmit and receive directions.

In the receive direction, if the KSZ8441 receives a PAUSE control frame at port 1, the KSZ8441 will not transmit the next normal frame until the timer, specified in the pause control frame, expires. If another PAUSE frame is received before the current timer expires, the timer will be updated with the new value in the second PAUSE frame. During this period (while it is flow controlled), only flow control packets from the KSZ8441 are transmitted.

In the transmit direction, the KSZ8441 has intelligent and efficient ways to determine when to invoke flow control and send PAUSE frames. The flow control is based on availability of the system resources, including available buffers, available transmit queues and available receive queues.

The KSZ8441 issues a PAUSE control frame containing the maximum pause time defined in IEEE standard 802.3x. Once the resource is freed up, the KSZ8441 then sends out another flow control frame with zero pause time to turn off the flow control (turn on transmission to the port). A hysteresis feature is provided to prevent the flow control mechanism from being constantly activated and deactivated.

On the host port, a flow control handshake exists internally between the QMU and the MAC. In the QMU, there are three programmable threshold levels for flow control in the RXQ FIFO:

1. Low water mark register FCLWR (0x1B0)
2. High water mark register FCHWR (0x1B2)
3. Overrun water mark register FCOWR (0x1B4)

The QMU will send a PAUSE frame internally to the MAC when the RXQ buffer fills with egress packets above the high water mark level (default 3.072 Kbytes available), and a stop PAUSE frame when the RXQ buffer drops below the low water mark level (default 5.12 Kbytes available). The QMU will drop packets when the RXQ buffer fills beyond the overrun water mark level (default 256 bytes available).

## 3.2.7 HALF-DUPLEX BACKPRESSURE

A half-duplex backpressure option (non-IEEE 802.3 standards) is also provided. The activation and deactivation conditions are the same as in full-duplex mode. If backpressure is required, the KSZ8441 sends preambles to defer the other stations' transmission (carrier sense deference).

To avoid jabber and excessive deference (as defined in the 802.3 standard), after a certain time, the KSZ8441 discontinues the carrier sense and then raises it again quickly. This short silent time (no carrier sense) prevents other stations from sending out packets thus keeping other stations in a carrier sense deferred state. If the port has packets to send during a backpressure situation, the carrier sense type backpressure is interrupted and those packets are transmitted instead. If there are no additional packets to send, carrier sense type backpressure is reactivated again until chip resources free up. If a collision occurs, the binary exponential back-off algorithm is skipped and carrier sense is generated immediately, thus reducing the chance of further collision and carrier sense is maintained to prevent packet reception.

To ensure no packet loss in 10BASE-T or 100BASE-TX half-duplex mode, the user must enable the following bits:

- Aggressive back-off (bit [8] in GGCR1)
- Backpressure flow control enable (bit [11] in P1CR2)

Please note that these bits are not set in default because this is not the IEEE standard.

## 3.2.8 ADDRESS FILTERING FUNCTION

The KSZ8441 supports 11 different address filtering schemes as shown in [Table 3-2](#). The Ethernet destination address (DA) field inside the packet is the first 6-byte field is compared with either the host MAC address registers (0x110 – 0x115) or the MAC address hash table registers (0x1A0 – 0x1A7) for address filtering operation. The first bit (bit[40]) of the destination address (DA) in the Ethernet packet decides whether this is a physical address if bit[40] is “0” or a multicast address if bit[40] is “1”.

# KSZ8441HL/FHL

**TABLE 3-2: MAC ADDRESS FILTERING SCHEME**

Item	Address Filtering Mode	Receive Control Register (0x174 – 0x175): RXCR1				Description
		RX ALL (Bit [4])	RX Inverse (Bit [1])	RX Physical Address (Bit [11])	RX Multicast Address (Bit [8])	
1	Perfect	0	0	1	1	All Rx frames are passed only if the DA exactly matches the MAC Address in MARL, MARM and MARH registers.
2	Inverse Perfect	0	1	1	1	All Rx frames are passed if the DA is not matching the MAC Address in MARL, MARM, and MARH registers.
3	Hash Only	0	0	0	0	All Rx frames with either multicast or physical destination address are filtering against the MAC address hash table.
4	Inverse Hash Only	0	1	0	0	All Rx frames with either multicast or physical destination address are filtering not against the MAC address hash table. All Rx frames which are filtering out at item 3 (Hash only) only are passed in this mode.
5	Hash Perfect (Default)	0	0	1	0	All Rx frames are passed with physical address (DA) matching the MAC Address and to enable receive multicast frames that pass the hash table when Multicast address is matching the MAC address hash table.
6	Inverse Hash Perfect	0	1	1	0	All Rx frames which are filtering out at item 5 (hash perfect) only are passed in this mode.
7	Promiscuous	1	1	0	0	All Rx frames are passed without any conditions.
8	Hash Only with Multicast Address Passed	1	0	0	0	All Rx frames are passed with physical address (DA) matching the MAC Address hash table and with Multicast address without any conditions.
9	Perfect with Multicast Address Passed	1	0	1	1	All Rx frames are passed with physical address (DA) matching the MAC Address and with Multicast address without any conditions.
10	Hash Only with Physical Address Passed	1	0	1	0	All Rx frames are passed with Multicast address matching the MAC Address hash table and with physical address without any conditions.
11	Perfect with Physical Address Passed	1	0	0	1	All Rx frames are passed with Multicast address matching the MAC Address and with physical address without any conditions.

Bit [0] (RX Enable), Bit [5] (RX Unicast Enable) and Bit [6] (RX Multicast Enable) must be set to 1 in RXCR1 register. The KSZ8441 will discard frame with SA same as the MAC Address if bit[0] is set in RXCR2 register.



## 3.3 Queue Management Unit (QMU)

The Queue Management Unit (QMU) manages packet traffic between the internal MAC and the external host processor interface. It has built-in packet memory for receive and transmit functions called TXQ (transmit queue) and RXQ (receive queue). The RXQ capacity is 12 Kbytes, and the TXQ capacity is 6 Kbytes. These FIFOs support back-to-back, non-blocking frame transfer performance. There are control registers for system control, frame status registers for current packet transmit/receive status, and interrupts to inform the host of the real time TX/RX status.

Please note that when referencing the QMU block, directions are described from the point of view of the external host processor. Thus, “transmit” indicates data flow from the host processor into the KSZ8441, while “receive” indicates data flow out of the KSZ8441 to the external host.

### 3.3.1 TRANSMIT QUEUE (TXQ) FRAME FORMAT

The frame format for the transmit queue is shown in [Table 3-3](#). The first word contains the control information for the frame to transmit. The second word is used to specify the total number of bytes of the frame. The packet data follows. The packet data area holds the frame itself. It may or may not include the CRC checksum depending upon whether hardware CRC checksum generation is enabled in bit [1] in TXCR register.

Multiple frames can be pipelined in both the transmit queue and receive queue as long as there is enough queue memory, thus avoiding overrun. For each transmitted frame, the transmit status information for the frame is located in the TXSR (0x172) register.

**TABLE 3-3: FRAME FORMAT FOR TRANSMIT QUEUE**

Packet Memory Address Offset (Bytes)	Bit 15 2nd Byte	Bit 0 1st Byte
0	Control Word (High byte and low byte need to swap in Big-Endian mode)	
2	Byte Count (High byte and low byte need to swap in Big-Endian mode)	
4 - Up	Transmit Packet Data (Maximum size is 2000)	

Because multiple packets can be pipelined into the TX packet memory for transmit, the transmit status reflects the status of the packet that is currently being transferred on the MAC interface, which may or may not be the last queued packet in the TX queue.

The transmit control word is the first 16-bit word in the TX packet memory, followed by a 16-bit byte count. It must be word aligned. Each control word corresponds to one TX packet. [Table 3-4](#) gives the transmit control word bit fields.

**TABLE 3-4: TRANSMIT CONTROL WORD BIT FIELDS**

Bit	Description
15	TXIC Transmit Interrupt on Completion: When this bit is set, the KSZ8441 sets the transmit interrupt after the present frame has been transmitted.
14 - 6	Reserved
5 - 0	TXFID Transmit Frame ID: This field specifies the frame ID that is used to identify the frame and its associated status information in the transmit status register.

The transmit byte count specifies the total number of bytes to be transmitted from the TXQ. Its format is given in [Table 3-5](#).

**TABLE 3-5: TRANSMIT BYTE COUNT FORMAT**

Bit	Description
15 - 11	Reserved
10 - 0	TXBC Transmit Byte Count: Transmit Byte Count. Hardware uses the byte count information to conserve the TX buffer memory for better utilization of the packet memory. <b>Note:</b> The hardware behavior is unknown if an incorrect byte count information is written to this field. Writing a “0” value to this field is not permitted.

# KSZ8441HL/FHL

The data area contains six bytes of destination address (DA) followed by six bytes of source address (SA), followed by a variable-length number of bytes. On transmit, all bytes are provided by the CPU, including the source address. The KSZ8441 does not insert its own SA. The IEEE 802.3 frame length word (frame type in Ethernet) is not interpreted by the KSZ8441. It is treated transparently as data both for transmit operations.

## 3.3.2 FRAME TRANSMITTING PATH OPERATION IN TXQ

This section describes the typical register settings for transmitting packets from a host processor to the KSZ8441 using the generic bus interface. The user can use the default value for most of the transmit registers. [Table 3-6](#) describes all the registers which need to be set and used for transmitting single frames.

**TABLE 3-6: REGISTER SETTING FOR TRANSMIT FUNCTION BLOCK**

Register Name [bit](offset)	Description
TXCR[3:0](0x170) TXCR[8:5](0x170)	Set transmit control function as below: Set bit[3] to enable transmitting flow control. Set bit [2] to enable transmitting padding. Set bit[1] to enable transmitting CRC. Set bit [0] to enable transmitting block operation. Set transmit checksum generation for ICMP, UDP, TCP and IP packet.
TXMIR[12:0](0x178)	The amount of free transmit memory available is represented in units of byte. The TXQ memory (6 KByte) is used for both frame payload and control word.
TXQCR[0](0x180)	For single frame to transmit, set this bit[0] = "1" (manual enqueue). The KSZ8441 will enable current TX frame prepared in the TX buffer is queued for transmit; this is only transmit one frame at a time. <b>Note:</b> This bit is self-clearing after the frame is finished transmitting. The software should wait for the bit to be cleared before setting up another new TX frame.
TXQCR[1](0x180)	When this bit is written as "1", the KSZ8441 will generate interrupt (bit[6] in the ISR register) to CPU when TXQ memory is available based upon the total amount of TXQ space requested by CPU at TXNTFSR (0x19E) register. <b>Note:</b> This bit is self-clearing after the frame is finished transmitting. The software should wait for the bit to be cleared before set to "1" again.
RXQCR[3](0x182)	Set bit[3] to start DMA access from host CPU either read (receive frame data) or write (transmit data frame)
TXFDPR[14](0x184)	Set bit[14] to enable TXQ transmit frame data pointer register increments automatically on accesses to the data register.
IER[14][6](0x190)	Set bit[14] to enable transmit interrupt in interrupt enable register. Set bit[6] to enable transmit space available interrupt in interrupt enable register.
ISR[15:0](0x192)	Write all ones (0xFFFF) to clear all interrupt status bits after interrupt occurred in interrupt enable register.
TXNTFSR[15:0](0x19E)	The host CPU is used to program the total amount of TXQ buffer space which is required for next total transmit frames size in double-word count.

## 3.3.3 DRIVER ROUTINE FOR TRANSMITTING PACKETS FROM HOST PROCESSOR TO KSZ8441

The transmit routine is called by the upper layer to transmit a contiguous block of data through the Ethernet controller. It is the user's choice to decide how the transmit routine is implemented. If the Ethernet controller encounters an error while transmitting the frame, it's the user's choice to decide whether the driver should attempt to retransmit the same frame or discard the data. [Figure 3-5](#) shows the step-by-step process for transmitting a single packet from host processor to the KSZ8441.

Each DMA write operation from the host CPU to the "write TXQ frame buffer" begins with writing a control word and a byte count of the frame header. At the end of the write, the host CPU must write each piece of frame data to align with a double word boundary at the end. For example, the host CPU has to write up to 68 bytes if the transmit frame is 65 bytes.

**FIGURE 3-5: HOST TX SINGLE FRAME IN MANUAL ENQUEUE FLOW DIAGRAM**

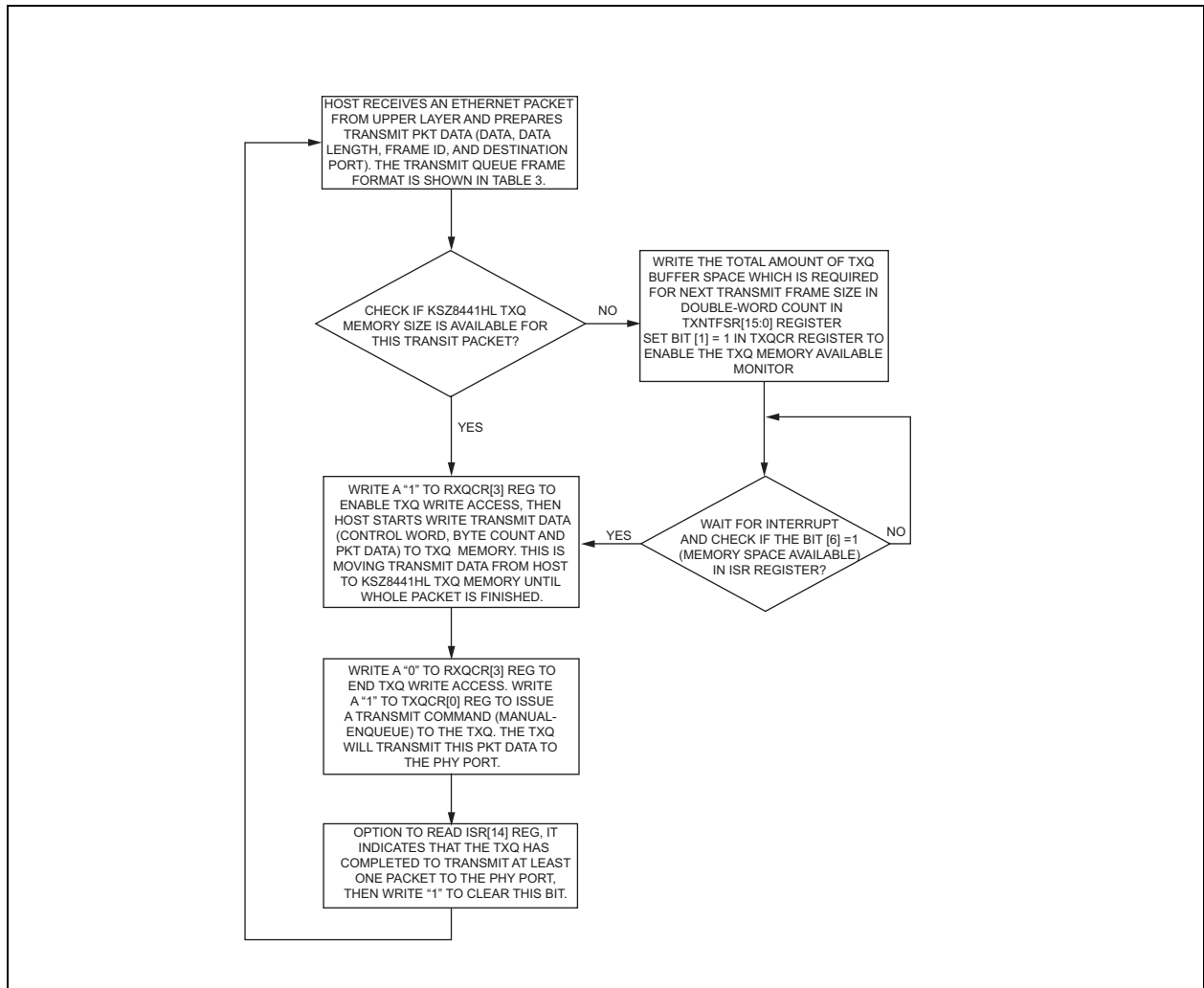

### 3.3.4 RECEIVE QUEUE (RXQ) FRAME FORMAT

The frame format for the receive queue is shown in [Table 3-7](#). The first word contains the status information for the frame received. The second word is the total number of bytes of the RX frame. Following that is the packet data area. The packet data area holds the frame itself. It includes the CRC checksum.

**TABLE 3-7: FRAME FORMAT FOR RECEIVE QUEUE**

Packet Memory Address Offset (Bytes)	Bit 15 2nd Byte	Bit 0 1st Byte
0	Status Word (High byte and low byte need to swap in Big-Endian mode. Also see description in RXFHSR register)	
2	Byte Count (High byte and low byte need to swap in Big-Endian mode. Also see description in RXFHBCR register)	
4 - Up	Receive Packet Data (Maximum size is 2000)	

# KSZ8441HL/FHL

## 3.3.5 FRAME RECEIVING PATH OPERATION IN RXQ

This section describes the typical register settings for receiving packets from KSZ8441 to the host processor via the generic host bus interface. Users can use the default value for most of the receive registers. [Table 3-8](#) describes all registers which need to be set and used for receiving single or multiple frames.

**TABLE 3-8: REGISTER SETTINGS FOR RECEIVE FUNCTION BLOCK**

Register Name [bit](offset)	Description
RXCR1 (0x174) RXCR2 (0x176)	Set receive control function as below: Set RXCR1[10] to enable receiving flow control. Set RXCR1[0] to enable receiving block operation. Set receive checksum check for ICMP, UDP, TCP, and IP packet. Set receive address filtering scheme.
RXFHSR[15:0] (0x17C)	This register (read only) indicates the current received frame header status information.
RXFHBCR[11:0] (0x17E)	This register (read only) indicates the current received frame header byte count information.
RXQCR[12:3] (0x182)	Set RXQ control function as below: Set bit[3] to start DMA access from host CPU either read (receive frame data) or write (transmit data frame). Set bit[4] to automatically enable RXQ frame buffer de-queue. Set bit[5] to enable RX frame count threshold and read bit[10] for status. Set bit[6] to enable RX data byte count threshold and read bit[11] for status. Set bit[7] to enable RX frame duration timer threshold and read bit[12] for status. Set bit[9] to enable RX IP header two-byte offset.
RXFDPR[14] (0x186)	Set bit[14] to enable RXQ address register increments automatically on accesses to the data register.
RXDTTR[15:0] (0x18C)	Used to program the received frame duration timer value. When Rx frame duration in RXQ exceeds this threshold in 1 $\mu$ s interval count and bit[7] of RXQCR register is set to "1", the KSZ8441 will generate RX interrupt in ISR[13] and indicate the status in RXQCR[12].
RXDBCTR[15:0] (0x18E)	Used to program the received data byte count value. When the number of received bytes in RXQ exceeds this threshold in byte count and bit [6] of RXQCR register is set to "1", the KSZ8441 will generate RX interrupt in ISR[13] and indicate the status in RXQCR[11].
IER[13] (0x190)	Set bit[13] to enable receive interrupt in interrupt enable register.
ISR[15:0] (0x192)	Write all ones (0xFFFF) to clear all interrupt status bits after interrupt occurred in interrupt status register.
RXFC[15:8] (0x1B8)	Rx Frame Count. This indicates the total number of frames received in the RXQ frame buffer when the receive interrupt (Reg. ISR, bit [13]) occurred.
RXFCTR[7:0] (0x19C)	Used to program the received frame count threshold value. When the number of received frames in RXQ exceeds this threshold value and bit[5] of RXQCR register is set to "1", the KSZ8441 will generate an RX interrupt in ISR[13] and indicate the status in RXQCR[10].

## 3.3.6 DRIVER ROUTINE FOR RECEIVING PACKETS FROM THE KSZ8441 TO THE HOST PROCESSOR

The software driver receives data packet frames from the KSZ8441 device either as a result of polling or an interrupt based service. When an interrupt is received, the operating system invokes the interrupt service routine that is in the interrupt vector table.

If your system has operating system support, to minimize interrupt lockout time, the interrupt service routine should handle at interrupt level only those tasks that require minimum execution time, such as error checking or device status change. The routine should queue all the time-consuming work to transfer the packet from the KSZ8441 RXQ into system memory at task level. [Figure 3-6](#) shows the step-by-step for receive packets from KSZ8441 to host processor.

Note: For each DMA read operation from the host CPU to read the RXQ frame buffer, the first read data (byte in 8-bit bus mode, word in 16-bit bus mode) is dummy data and must be discarded by the host CPU. Afterward, the host CPU must read each data frame to align it with a double word boundary at the end. For example, the host CPU has to read up to 68 bytes if the number of received frames is 65 bytes.

**FIGURE 3-6: HOST RX SINGLE OR MULTIPLE FRAMES IN AUTO-DEQUEUE FLOW DIAGRAM**

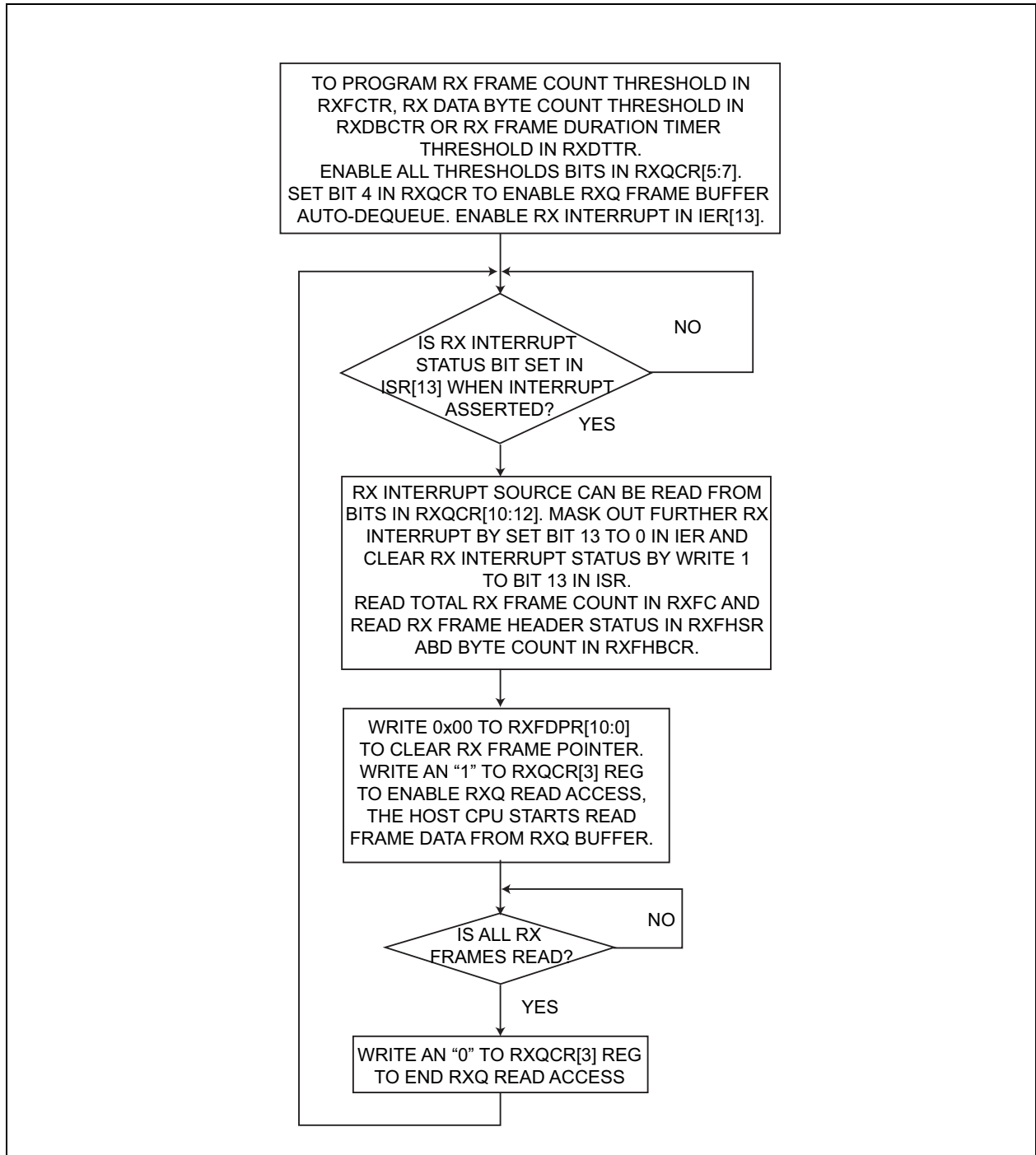

# KSZ8441HL/FHL

---

In order to read received frames from RXQ without error, the software driver must follow these steps:

1. When a receive interrupt occurs and the software driver writes a “1” to clear the RX interrupt in the ISR register; the KSZ8441 will update the Rx frame counter (RXFC) register for this interrupt.
2. When the software driver reads back the Rx frame count (RXFC) register, the KSZ8441 will update both the receive frame header status and byte count registers (RXFHSR/RXFHBCR).
3. When the software driver reads back both the receive frame header status and byte count registers (RXFHSR/RXFHBCR), the KSZ8441 will update the next receive frame header status and byte count registers (RXFHSR/RXFHBCR).

## 3.4 IEEE 1588 Precision Time Protocol (PTP) Block

The IEEE 1588 precision time protocol (PTP) provides a method for establishing synchronized time across nodes in an Ethernet networking environment. The KSZ8441 implements V2 (2008) of the IEEE 1588 PTP specification.

The KSZ8441 controller implements the IEEE 1588 PTP Version 2 protocol. Port 1 can be programmed as either an end-to-end (E2E) or peer-to-peer (P2P) transparent clock (TC) port. The host port can also be programmed as either a slave or master ordinary clock (OC) port. Ingress time stamp capture, egress time stamp recording, correction field update with residence time and link delay, delay turn-around time insertion, egress time stamp insertion, and checksum update are supported. PTP frame filtering is implemented to enhance overall system performance. Delay adjustments are implemented to fine tune the synchronization. Versatile event trigger outputs and time stamp capture inputs are implemented to meet various real time application requirements through the GPIO pins.

The key features of the KSZ8441 implementation are as follows:

- Both one-step and two-step TC operations are supported
- Implementation of precision time clock per specification (Upper 16 bits of second clock not implemented due to practical values of time)
- Both E2E and P2P TC are supported on port 1
- Both slave and master OC are supported on the host port
- PTP multicast and unicast frames are supported
- Transports of PTP over IPv4/IPv6 UDP and IEEE 802.3/Ethernet are supported
- Both peer delay request-response and peer delay mechanism are supported
- Precision time stamping of input signals on the GPIO pins
- Creation and delivery of clocks, pulses, or other unique serial bit streams on the GPIO pins with respect to precise Precision time protocol time.

IEEE 1588 defines two essential functions: The measurement of link and residence (switching) delays by using the Delay\_Req/Resp or Pdelay\_Req/Resp message, and the distribution of time information by using the Sync/Follow\_Up messages. The 1588 PTP event messages are periodically sent from the grandmaster(s) in the network to all slave clock devices. Link delays are measured by each slave node to all its link partners to compensate for the delay of PTP messages sent through the network.

The 1588 PTP Announce messages are periodically sent from the grandmaster(s) in the network to all slave clock devices. This information is then used by each node to select a master clock using the best master algorithm available.

1588 PTP (Version 2) defines two types of messages; event and general messages. These are summarized below and are supported by the KSZ8441:

Event Messages (an accurate time stamp is generated at egress and ingress):

- Sync (from Master to Slave)
- Delay\_Req (from Slave to Master)
- Pdelay\_Req (between link partners for peer delay measurement)
- Pdelay\_Resp (between link partners for peer delay measurement)

General Messages:

- Follow\_Up (from Master to Slave)
- Delay\_Resp (from Master to Slave)
- Pdelay\_Resp\_Follow\_Up (between link partners for peer delay measurement)
- Announcement
- Management

- Signaling

## 3.4.1 IEEE 1588 PTP CLOCK TYPES

The KSZ8441 supports the following clock types:

- Ordinary Clock (OC) is defined as a PTP clock with a single PTP port in a PTP domain. It may serve as a source of time such as a master clock, or it may be a slave clock which synchronizes to another master clock.
- End-to-End Transparent Clock (E2E TC) is defined as a transparent clock that supports the use of the end-to-end delay measurement mechanism between a slave clock and the master clock. In this method, the E2E TC intermediate devices do not need to be synchronized to the master clock and the end slave node is directly synchronized to the master clock. The E2E TC/SC slave intermediate devices can also be synchronized to the master clock. Note that the transparent clock is not a real clock that can be viewed on an oscilloscope but rather it is a mechanism by which delay are accounted for when transporting information across and through physical network nodes.
- Peer-to-Peer Transparent Clock (P2P TC for Version 2) is defined as a transparent clock, in addition to providing PTP event transit time information. P2P TC also provides corrections for the propagation delay between nodes (link partners) by using Pdelay\_Req (Peer Delay Request) and Pdelay\_Resp (Peer Delay Response). In this method, the P2P TC intermediate devices can be synchronized to the master clock. A transparent clock (TC) is not part of the master-slave hierarchy. Instead, it measures the resident time which is the time taken for a PTP message to traverse the node. The P2P TC then provides this information to the clock receiving the PTP message. In addition, the P2P TC measures and passes on the link delay of the receiving PTP message. Note that the transparent clock is not a real clock that can be viewed on an oscilloscope but rather it is a mechanism by which delay are accounted for when transporting information across and through physical network nodes.
- Master Clock is defined as a clock which is used as the reference clock for the entire system. The KSZ8441 can operate as a master clock if needed. However, the quality of the clock signal will be limited by the quality of the crystal or oscillator used to clock the device.

Note that P2P and E2E TCs cannot be mixed on the same communication path.

## 3.4.2 IEEE 1588 PTP ONE-STEP OR TWO-STEP CLOCK OPERATION

The KSZ8441 supports either 1-step or 2-step clock operation.

- One-Step Clock Operation: A PTP message (Sync) exchange that provides time information using a single event message which eliminates the need for a Follow\_Up message to be sent. This one-step operation will eliminate the need for software to read the time stamp and to send a Follow\_Up message.
- Two-Step Clock Operation: A PTP messages (Sync/Follow\_Up) that provides time information using the combination of an event message and a subsequent general message. The Follow\_Up message carries a precise estimate of the time the Sync message was placed on the PTP communication path by the sending node.

## 3.4.3 IEEE 1588 PTP BEST MASTER CLOCK SELECTION

The IEEE 1588 PTP specification defines an algorithm based on the characteristics of the clocks and system topology called best master clock (BMC) algorithm. BMC uses announce messages to establish the synchronization hierarchy. The algorithm compares data from two clocks to determine the better clock. Each clock device continuously monitors the announce messages issued by the current master and compares the dataset to itself. The software controls this process.

## 3.4.4 IEEE 1588 PTP SYSTEM TIME CLOCK

The system time clock (STC) in KSZ8441 is a readable or writable time source for all IEEE 1588 PTP related functions and contains three counters: a 32-bit counter for seconds, a 30-bit counter for nanoseconds and a 32-bit counter for sub-nanoseconds (units of  $2^{-32}$  ns). Refer to [Figure 3-7](#) which shows the precision time protocol clock.

# KSZ8441HL/FHL

**FIGURE 3-7: PTP SYSTEM CLOCK OVERVIEW**

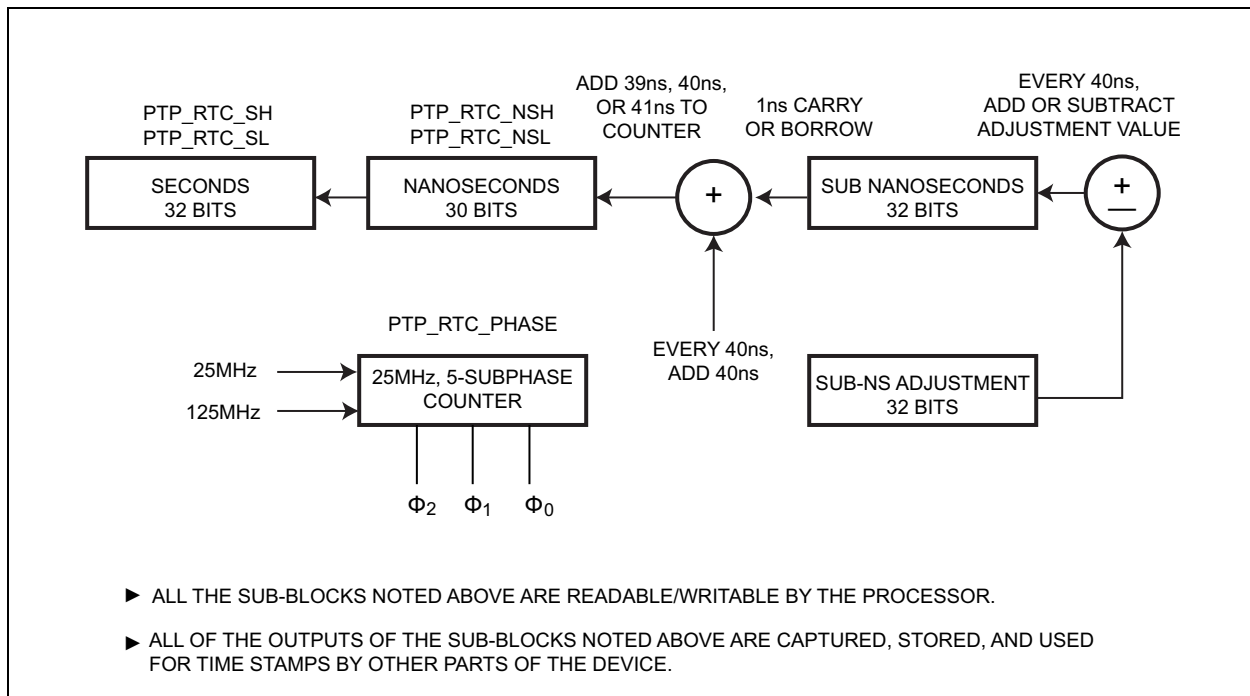

The STC is clocked (incremented by 40 ns or updated with sub ns carry info) every 40 ns by a derivative of the 125 MHz derived clock. The 30-bit nanosecond counter will be numerically incremented by 39 ns, 40 ns, or 41 ns every 40 ns. There is another 3-bit phase counter that is designed to indicate one of the five sub phases (0 ns, 8 ns, 16 ns, 24 ns, or 32 ns) within the 40 ns period. This provides finer resolution for the various messages and time stamps. The overflow for the 30-bit nanosecond counter is 0x3B9ACA00 (109) and the overflow for the 32-bit sub-nanosecond counter is 0xFFFFFFFF.

The system time clock does not support the upper 16-bits of the seconds field as defined by the IEEE 1588 PTP Version 2 which specifies a 48-bit seconds field. If the 32-bit seconds counter overflows, it will have to be handled by software. Note that an overflow of the seconds field only occurs every 136 years.

The seconds value is kept track of in the PTP\_RTC\_SH and PTP\_RTC\_SL registers (0x608 – 0x60B). The nanoseconds value is kept track of in the PTP\_RTC\_NSH and PTP\_RTC\_NSL registers (0x604 – 0x607).

The PTP\_RTC\_PHASE clock register (0x60C – 0x60D) is initialized to zero whenever the local processor writes to the PTP\_RTC\_NSL, PTP\_RTC\_NSH, PTP\_RTC\_SL, or PTP\_RTC\_SH registers.

During normal operation when the STC clock is keeping synchronized real time, and not while it is undergoing any initialization manipulation by the processor to get it close to the real time, the PTP\_RTC\_PHASE clock register will be reset to zero at the beginning of the current 40 ns STC clock update interval. It will start counting at zero at the beginning of the 40 ns period and every 8 ns it will be incremented. The information provided by the PTP\_RTC\_PHASE register will increase the accuracy of the various timestamps and STC clock readings.

### 3.4.5 UPDATING THE SYSTEM TIME CLOCK

The KSZ8441 provides four mechanisms for updating the system time clock:

- Directly Setting or Reading the Time
- Step-Time Adjustment
- Continuous Time Adjustment
- Temporary Time Adjustment



## 3.4.5.1 Directly Setting or Reading the Time

Directly setting the system time clock to a value is accomplished by setting a new time in the real time clock registers (PTP\_RTC\_SH/L, PTP\_RTC\_NSH/L and PTP\_RTC\_PHASE) and then setting the load PTP 1588 clock bit (PTP\_LOAD\_CLK).

Directly reading the system time clock is accomplished by setting the read PTP 1588 clock bit (PTP\_READ\_CLK). To avoid lower bits overflowing during reading the system time clock, a snapshot register technique is used. The value in the system time clock will be saved into a snapshot register by setting the PTP\_READ\_CLK bit in PTP\_CLK\_CTL, and then subsequent reads from PTP\_RTC\_S, PTP\_RTC\_NS, and PTP\_RTC\_PHASE will return the system time clock value. The CPU will add the PTP\_RTC\_PHASE value to PTP\_RTC\_S and PTP\_RTC\_NS to get the exact real time.

## 3.4.5.2 Step-Time Adjustment

The system time clock can be incremented in steps if desired. The nanosecond value (PTP\_RTC\_NSH/L) can be added or subtracted when the PTP\_STEP\_ADJ\_CLK bit is set. The value will be added to the system time clock if this action occurs while the PTP\_STEP\_DIR bit = "1". The value will be subtracted from the system time clock if this action occurs while the PTP\_STEP\_DIR bit = "0". The PTP\_STEP\_ADJ\_CLK bit is self-clearing.

## 3.4.5.3 Continuous Time Adjustment

The system can be set up to perform continuous time adjustment to the 1588 PTP clock. This is the mode that is anticipated to be used the most. This mode is overseen by the local processor and provides a method of periodically adjusting the count of the PTP clock to match the time of the master clock as best as possible. The rate registers (PTP\_SNS\_RATE\_H and PTP\_SNS\_RATE\_L) (0x610 – 0x613) are used to provide a value by which the sub-nanosecond portion of the clock is adjusted on a periodic basis. While continuous adjustment mode (PTP\_CONTINU\_ADJ\_CLK = "1") is selected every 40 ns the sub-nanosecond value of the clock will be adjusted in either a positive or negative direction as determined by the PTP\_RATE\_DIR bit. The value will be positively adjusted if PTP\_RATE\_DIR = "0" or negatively adjusted if PTP\_RATE\_DIR = "1". The rate adjustment allows for correction with resolution of  $2^{-32}$  ns for every 40 ns reference clock cycle, and it will be added to or subtracted from the system time clock on every reference clock cycle right after the write to PTP\_SNS\_RATE\_L is done. To stop the continuous time adjustment, one can either set the PTP\_CONTINU\_ADJ\_CLK = "0" or the PTP\_SNS\_RATE\_H/L value to zero.

## 3.4.5.4 Temporary Time Adjustment

This mode allows for the continuous time adjustment to take place over a specified period of time only. The period of time is specified in the PTP\_ADJ\_DURA\_H/L registers. This mode is enabled by setting the PTP\_TEMP\_ADJ\_CLK bit to one. Once the duration is reached, the increment or decrement will cease. When the temporary time adjustment is done, the internal duration counter register (PTP\_ADJ\_DURA\_H/L) will stay at zero, which will disable the time adjustment. The local processor needs to set the PTP\_TEMP\_ADJ\_CLK to one again to start another temporary time adjustment with the reloaded value into the internal rate and duration registers. The PTP\_ADJ\_DURA\_L register needs to be programmed before PTP\_ADJ\_DURA\_H register. The PTP\_ADJ\_DURA\_L, PTP\_ADJ\_DURA\_H and PTP\_SNS\_RATE\_L registers need to be programmed before the PTP\_SNS\_RATE\_H register. The temporary time adjustment will start after the PTP\_TEMP\_ADJ\_CLK bit is set to one. This bit is self-cleared when the adjustment is completed. Software can read this bit to check whether the adjustment is still in progress.

## 3.4.5.5 PTP Clock Initialization

During software initialization when the device is powering up, the PTP clock needs to be initialized in preparation for synchronizing to the master clock. The suggested order of tasks is to reset the PTP 1588 clock (RESET\_PTP\_CLK = "0"), load the PTP 1588 clock (PTP\_LOAD\_CLK = "1") with a value then enable the PTP 1588 clock (EN\_PTP\_CLK = "1"). During the initial synchronization attempt, the system time clock may be a little far apart from the PTP master clock, so it most likely will require a step-time adjustment to get it closer. After that, the continuous time adjustment method or temporary time adjustment method may be the best options when the system time clock is close to being synchronized with the master clock.

More details on the 1588 PTP system time clock controls and functions can be found in the register descriptions for registers 0x600 to 0x617.

## 3.4.6 IEEE 1588 PTP MESSAGE PROCESSING

The KSZ8441 supports IEEE 1588 PTP time synchronization when 1588 PTP mode and message detection are enabled in the PTP\_MSG\_CFG\_1 register (0x620 – 0x621). Different operations will be applied to PTP packet processing based on the setting of P2P or E2E in transparent clock mode for Port 1, master or slave in ordinary clock mode for the host port, one-step or two-step clock mode, and if domain checking is enabled. For the IPv4/UDP egress packet,

# KSZ8441HL/FHL

---

the checksum can be updated by either re-calculating the two-bytes or by setting it to zero. For the IPv6/UDP egress packet, the checksum is always updated. All these 1588 PTP configuration bits are in the PTP\_MSG\_CFG\_1 registers (0x620 – 0x621).

For a more detailed description of the 1588 PTP message processing control and function, please refer to the register descriptions in the register map at locations 0x620 to 0x68F.

## 3.4.6.1 IEEE 1588 PTP Ingress Packet Processing

The KSZ8441 can detect all IEEE 802.3 Ethernet 1588 PTP packets, IPv4/UDP 1588 PTP packets, and IPv6/UDP 1588 PTP packets by enabling these features in the PTP\_MSG\_CFG\_1 register (0x620 – 0x621). Upon detection of receiving a 1588 PTP packet, the device will capture the receive time stamp at the time when the Start of Frame Delimiter (SFD) is detected. Adjusting the receive time stamp with the value in the Receive Latency Register (PTP\_P1\_RX\_LATENCY) or by the value in the Asymmetry Correction Register (PTP\_P1\_ASYM\_COR) is the responsibility of the software. The hardware only takes these values into consideration when it updates the correction field in the PTP message header. Likewise, the software needs to adjust the transmit time stamp with the transmit latency. Both the ingress time stamp and the ingress port number will be embedded in the reserved fields of the 1588 PTP header. The embedded information will be used by the host to designate the destination port in the response egress packet, identify the direction of the master port, and to calculate the link delay and offset.

The 1588 PTP packet will be discarded if the 1588 PTP domain field does not match the domain number in the PTP\_DOMAIN\_VER register (0x624 – 0x625) or if the 1588 PTP version number does not match version number (either 1 or 2) in the PTP\_DOMAIN\_VER register (0x624 – 0x625). Packets with a version number of one will not be forwarded to the host port.

The 1588 PTP packets that are not associated with packet messages in pairs (Pdelay\_Req with Pdelay\_Resp, Sync with Follow\_Up, Delay\_Req with Delay\_Resp) can be filtered and not forwarded to the host port if the corresponding enable bits are set in the PTP\_MSG\_CFG\_2 register (0x0622 – 0x0623). The 1588 PTP version-1 packets will not be forwarded to the host port.

## 3.4.6.2 IEEE 1588 PTP Egress Packet Processing

The ingress time stamp, the transport type of the 1588 PTP packet, the packet type (tagged or untagged), and the type of correction field update on the egress side are in the frame header and are accessible for modification by the egress logic in local packet memory. The 1588 PTP packet will be put in the egress queue of highest priority. From the 1588 PTP frame header inside the packet memory, the egress logic will get the correction field update instruction. The residence time, link delay in the PTP\_P1\_LINK\_DLY registers (0x646 – 0x647) or turn-around time might be added to the correction field depending upon the type of 1588 PTP egress packet. The 1588 PTP packet received from the host port has the destination port information to forward and has the time stamp information that will be used for updating the correction field in one-step clock operation. This embedded information (in the reserved fields of 1588 PTP frame header) will be zeroed out before the egress packet is sent out to conform to the 1588 PTP standard.

For one-step operation, the original time stamp will be inserted into the Sync packet. The egress time stamp of the Sync packet will be latched in the P1\_SYNC\_TS registers (0x64C – 0x64F), the egress timestamps of Delay\_Req, Pdelay\_Req and Pdelay\_Resp will be latched in the P1/2\_XDLY\_REQ\_TS (0x648 – 0x64B and 0x668 – 0x66B) and P1\_P-DLY\_RESP\_TS registers (0x650 – 0x653). These latched egress timestamps will generate an interrupt to the host CPU and set the interrupt status bits in the PTP\_TS\_IS register (0x68C – 0x68D) if the interrupt enable is set in the PTP\_TS\_IE register (0x68E – 0x68F). These captured egress timestamps will be used by the 1588 PTP software for link delay measurement, offset adjustment, and time calculation.

The transmit delay value from the Port 1 time stamp reference point to the network connection point in the PTP\_P1\_TX\_LATENCY registers (0x640 – 0x641) will be added to these value in the P1\_SYNC\_TS, P1\_XDLY\_REQ\_TS and P1\_P-DLY\_RESP\_TS registers to get the egress time stamp with reference point to the network connection point. For transmit Delay\_Req or Pdelay\_Req packets, the value in the PTP\_P1\_ASYM\_COR registers (0x644 – 0x645) will be subtracted from the correction field.

## 3.4.7 IEEE 1588 PTP EVENT TRIGGERING AND TIME STAMPING

An event trigger output signal can be generated when the target and activation time matches the IEEE 1588 PTP system clock time. Likewise, an event time stamp input can be captured from an external event input signal and the corresponding time on the IEEE 1588 PTP system clock will be captured.

Up to seven GPIO pins can be configured as either output signal when trigger target time is matching IEEE 1588 PTP system clock time or monitoring input signal for external event time stamp. All event trigger outputs are generated by comparing the system clock time with trigger target time continuously to make sure time synchronization is always ongoing.

### 3.4.7.1 IEEE 1588 PTP Trigger Outputs

The KSZ8441 supports up to 12 trigger output units, which can output to any one of the seven GPIO pins by setting bits[3:0] in TRIG[1:12]\_CFG\_1 registers. Multiple trigger output units can be assigned to a single GPIO pin at the same time as logical OR'ed function, allowing generation of more complex waveforms. Multiple output trigger units can be cascaded (one unit only at any time) to drive a single GPIO pin to generate a long and repeatable bit sequence. Each trigger unit that is cascaded can be any signal type (edge, pulse, periodic, register-bits, and clock output).

Each trigger output unit can be programmed to generate one time rising or falling edge (toggle mode), a single positive or negative pulse of programmable width, a periodic signal of programmable width, cycle time, bit-patterns to shift out from TRIG[1:12]\_CFG\_[1:8] registers, and each trigger unit can be programmed to generate interrupt of trigger output unit done and status in PTP\_TRIG\_IE/IS registers. For each trigger unit, the host CPU programs the desired output waveform, GPIO pins, target time in TRIG[1:12]\_TGT\_NS and TRIG[1:12]\_TGT\_S registers that the activity is to occur, and enable the trigger output unit in TRIG\_EN register, then the trigger output signal will be generated on the GPIO pin when the internal IEEE 1588 PTP system time matches the desired target time. The device can be programmed to generate a pulse-per-second (PPS) output signal. The maximum trigger output signal frequency is up to 12.5 MHz.

For a more detailed description of the 1588 PTP trigger output control, configuration and function, please refer to the registers description in the register map from 0x200 to 0x397 locations.

### 3.4.7.2 IEEE 1588 PTP Event Time Stamp Input

External event inputs on the GPIO pins can be monitored and time stamped with the resolution of 8 ns. The external signal event can be monitored and detected as either rising edge, falling edge, positive pulse, or negative pulse by setting bits[7:6] in TS[1:12]\_CFG registers. Multiple time stamp input units can be cascaded or chained together to associate with a single GPIO pin to detect a series of events. When event is detected, the time stamp will be captured in three fields: 32-bit second field in TS[1:12]\_SMPL1\_SH/L registers, 30-bit nanosecond field in TS[1:12]\_SMPL1\_NSH/L registers, and 3-bit phase field in TS[1:12]\_SMPL1\_SUB\_NS registers. Second and nanosecond fields are updated every 25 MHz clock cycle. The 3-bit phase field is updated every 125 MHz clock cycle and indicates one of the five 8 nanosecond/125 MHz clock cycles. The bit [14] in TS[1:12]\_SMPL1\_NSH registers indicates the event time stamp input is either falling edge or rising edge.

The KSZ8441 supports up to twelve time stamp input units which can input from any one of the seven GPIO pins by setting bits[11:8] in TS[1:12]\_CFG registers. The enable bits [11:0] in TS\_EN register are used to enable the time stamp units. The last time stamp input unit (unit 12) can support up to eight time stamps for multiple event detection and up to four pulses can be detected. The rest of the units (units 1-11) have two time stamps to support single edge or pulse detection. Pulse width can be measured by the time difference between consecutive time stamps. When an input event is detected, one of the bits [11:0] in TS\_RDY register is asserted and will generate a time stamp interrupt if the PTP\_TS\_IE bit is set. The host CPU is also expected to read the time stamp status in the TS[1:12]\_STATUS registers to report the number of detected event (either rising or falling edge) counts and overflow. In cascade mode, it can store and detect up to two events at each of the eleven time stamp units and up to eight events in time stamp unit 12. Pulses or edges can be detected up to 25 MHz.

For more details on 1588 PTP event time stamp input control, configuration and function, please refer to the register descriptions for locations 0x400 to 0x5FD in the register map.

### 3.4.7.3 IEEE 1588 PTP Event Interrupts

All IEEE 1588 PTP event trigger and time stamp interrupts are located in the PTP\_TRIG\_IE/PTP\_TS\_IE enable registers and the PTP\_TRIG\_IS/PTP\_TS\_IS status registers. These interrupts are fully maskable via their respective enable bits and shared with other interrupts that use the INTRN interrupt pin.

These twelve event trigger output status interrupts are logical OR'ed together and connected to bit[10] in the ISR register.

These twelve event trigger output enable interrupts are logical OR'ed together and connected to bit[10] in the IER register.

These twelve time stamp status interrupts are logical OR'ed together with the rest of bits in this register and the logical OR'ed output is connected to bit[12] in the ISR register.

# KSZ8441HL/FHL

These twelve time stamp enable interrupts are logical OR'ed together with the rest of bits in this register and the logical OR'ed output is connected to bit[12] in the IER register.

## 3.4.7.4 IEEE 1588 GPIO

The KSZ8441 supports seven GPIO pins that can be used for general I/O or can be configured to utilize the timing of the IEEE 1588 protocol. These GPIO pins can be used for input event monitoring, outputting pulses, outputting clocks, or outputting unique serial bit streams. The GPIO output pins can be configured to initiate their output upon the occurrence of a specific time which is being kept by the on-board Precision Time Clock. Likewise, the specific time of arrival of an input event can be captured and recorded with respect to the Precision Time Clock. Refer to the next section for details on the operation of the GPIO pins.

## 3.5 General Purpose and IEEE 1588 Input/Output (GPIO)

### 3.5.1 OVERVIEW

The KSZ8441 devices incorporate a set of general purpose input/output (GPIO) pins that are configurable to meet the needs of many applications. The input and output signals on the GPIO pins can be directly controlled via a local processor or they can be set up to work closely with the IEEE 1588 protocol to create and/or monitor precisely timed signals which are synchronous to the precision time clock. Some GPIO pins are dedicated, while others are dual function pins. Dual function pins are managed by the IOMUXSEL register. [Table 3-9](#) provides a convenient summary of available GPIO resources in the KSZ8441.

**TABLE 3-9: GPIO PIN RESOURCES**

GPIO	Pin Number	Function
GPIO_0	48	GPIO0
GPIO_1	49	GPIO1
GPIO_2	52	GPIO2
GPIO_3	53	EESK (default)/GPIO3
GPIO_4	54	EEDIO (default)/GPIO4
GPIO_5	55	EECS (default)/GPIO5
GPIO_6	58	GPIO6

### 3.5.2 GPIO PIN FUNCTIONALITY CONTROL

The GPIO\_OEN register is used to configure each GPIO as an input or an output. Each GPIO pin has a set of registers associated with it that are configured to determine its functionality, and any relationship it has with other GPIO pins or registers. Each GPIO pin can be configured to output a binary signal state or a serial sequence of bits. Each GPIO pin can output a single serial bit pattern or it can be programmed to continuously loop and output the pattern until stopped. The duration of the high and low periods within the sequential bit patterns can be programmed to meet the requirements of the application. The output can be triggered to occur at any time by the local processor writing to the correct register or it can be triggered by the local IEEE Precision Timing Protocol Clock being equal to an exact time. The local processor can interrogate any GPIO pin at any time or the value of the IEEE precision Time Protocol Clock can be captured and recorded when the specified event occurs on any of the GPIO pins. The control and output of the GPIO pins can be cascaded to create complex digital output sequences and waveforms. Lastly, the units can be programmed to generate an interrupt on specific conditions.

The control structure for the eleven pins is organized into two separate units called the trigger output units (TOU) and the time stamp input units (TSU). There are twelve TOUs and twelve TSUs which can be used with any of the GPIO pins. There are 32 control bytes for each of the two units to control the functionality. The depth of control is summarized in [Table 3-10](#).

**TABLE 3-10: TRIGGER OUTPUT UNITS AND TIME STAMP INPUT UNITS SUMMARY**

Trigger Output Units	Time Stamp Input Units
32 Bytes of Parameters	32 Bytes of Parameters
Trigger Patterns: Negative Edge, Positive Edge, Negative Pulse, Positive Pulse, Negative Period, Positive Period, Register Output Shift	Detection: Negative or Positive Edges Negative or Positive Pulses

**TABLE 3-10: TRIGGER OUTPUT UNITS AND TIME STAMP INPUT UNITS SUMMARY (CONTINUED)**

Trigger Output Units	Time Stamp Input Units
Pulse Width: 16-Bit Counter @ 8 ns Each (524288 ns, maximum)	Two Edge/One Pulse (Two Time Stamps) Detection Capability (time stamp Units 10:0)
Cycle Width: 32-Bit Counter @ 1 ns Each (4.29 seconds, maximum)	Eight Edge/Four Pulse (Eight Time Stamps) Detection (time stamp Unit 11)
Cycle Count: 16-Bit Counter (0 = Infinite Loop)	Cascadable to Detect Multiple Edges
Total Cascade Mode Cycle Time: 32-Bit Counter @ 1 ns Each	—
Shift Register: 16-Bits (only for register shift output mode)	—
Cascadable to Generate Complex Waveforms	—

### 3.5.3 GPIO PIN CONTROL REGISTER LAYOUT

Most of the registers used to control the time stamp units and the trigger output units are duplicated for each GPIO pin.

There are a few registers that are associated with all the overall functionality of all the GPIO pins or only specific GPIO pins. These are summarized in [Table 3-11](#).

**TABLE 3-11: GPIO REGISTERS AFFECTING EITHER ALL OR SPECIFIC UNITS**

Register Name	Register Location	Related to Which Trigger Output Units or Time Stamping Units
Trigger Error Register – TRIG_ERR	0x200 – 0x201	All GPIO trigger output units.
Trigger Active Register – TRIG_ACTIVE	0x202 – 0x203	All GPIO trigger output units.
Trigger Done Register – TRIG_DONE	0x204 – 0x205	All GPIO trigger output units.
Trigger Enable Register – TRIG_EN	0x206 – 0x207	All GPIO trigger output units.
Trigger SW Reset Register – TRIG_SW_RST	0x208 – 0x209	All GPIO trigger output units.
Trigger Unit 12 Output PPS Pulse-Width Register – TRIG12_PPS_WIDTH	0x20A – 0x20B	GPIO trigger output Unit 1, 12.
Time Stamp Ready Register – TS_RDY	0x400 – 0x401	All GPIO time stamp input units.
Time Stamp Enable Register – TS_EN	0x402 – 0x403	All GPIO time stamp input units.
Time Stamp Software Reset Register – TS_SW_RST	0x404 – 0x405	All GPIO time stamp input units.

# KSZ8441HL/FHL

**FIGURE 3-8: TRIGGER OUTPUT UNIT ORGANIZATION AND ASSOCIATED REGISTERS**

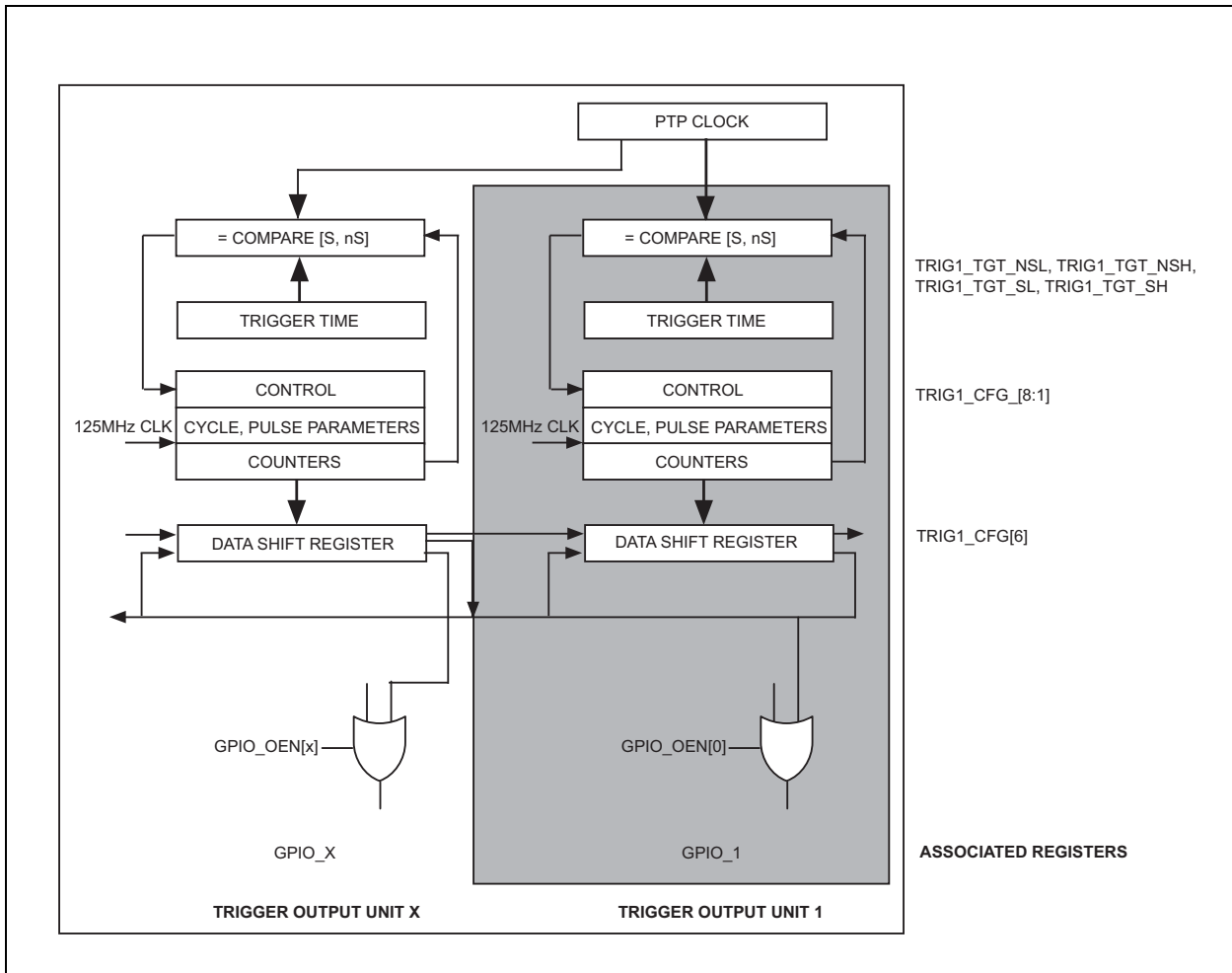

**FIGURE 3-9: TIME STAMP INPUT UNIT ORGANIZATION AND ASSOCIATED REGISTERS**

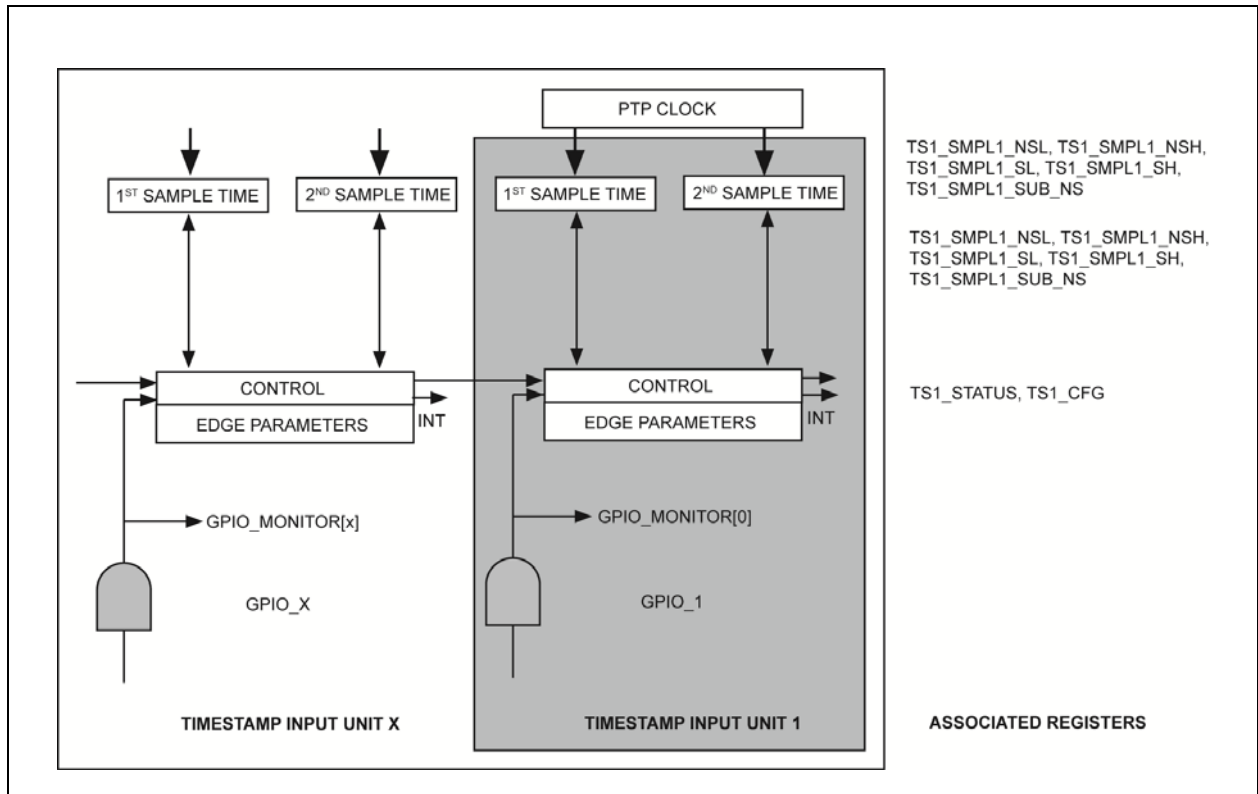

### 3.5.4 GPIO TRIGGER OUTPUT UNIT AND TIME STAMP INPUT UNIT INTERRUPTS

The trigger output units and the time stamp input units can be programmed to generate interrupts when specified events occur. The interrupt control structure is shown in [Figure 3-10](#) and [Figure 3-11](#).

**FIGURE 3-10: TRIGGER UNIT INTERRUPTS**

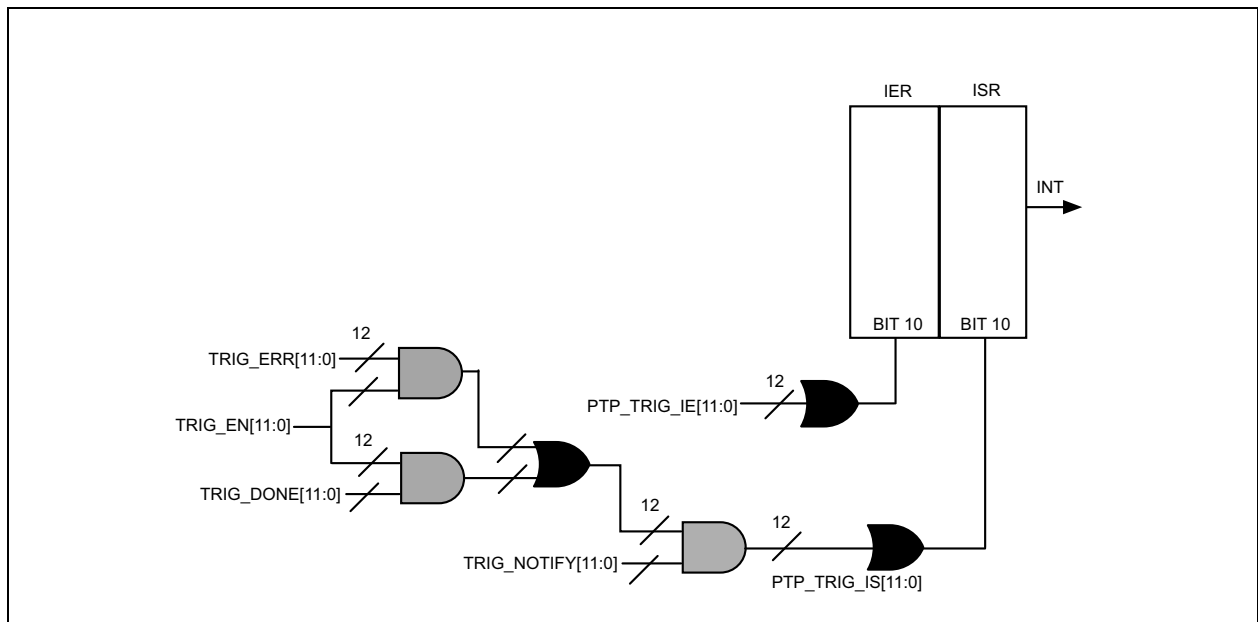

**FIGURE 3-11: TIME STAMP UNIT INTERRUPTS**

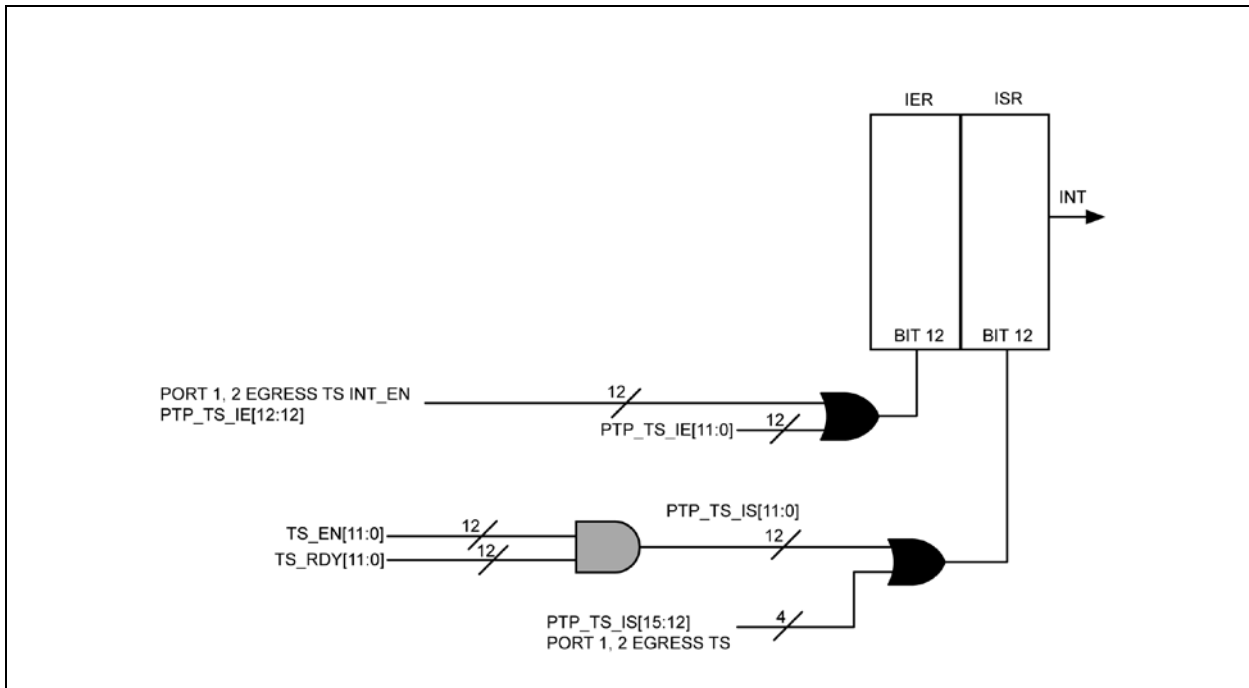

## 3.6 Using the GPIO Pins with the Trigger Output Units

The twelve trigger output units (TOU) can be used to generate a variety of pulses, clocks, waveforms, and data streams at user-selectable GPIO pins. The TOUs will generate the user-specified output starting at a specific time with respect to the IEEE 1588 precision time clock. This section provides some information on configuring the TOUs to generate specific types of output. In the information below, the value “x” represents one of the twelve TOUs. Because this area of the device is very flexible and powerful, please reference application note [ANLAN203, KSZ84xx GPIO Pin Output Functionality](#), for additional information on creating specific types of waveforms and utilizing this feature.

When using a single TOU to control multiple GPIO pins, there are several details of functionality that must be taken into account. When switching between GPIO pins, the output value on those pins can be affected. If a TOU changes the GPIO pin level to a high value, writing to this units configuration register to change the addressed GPIO pin to a different one will cause the hardware to drop the level in the previous GPIO pin and set the new GPIO pin to a high value. To prevent the second GPIO pin from going high immediately, the TOU must be reset prior to programming in a different GPIO pin value.

### 3.6.1 CREATING A LOW-GOING PULSE AT A SPECIFIC TIME

- Specifying the Time

The desired trigger time will be set in TRIGx\_TGT\_NSH, TRIGx\_TGT\_NSL, TRIGx\_TGT\_SH, and TRIGx\_TGT\_SL registers.

- Specifying the Pulse Parameters

TRIGx\_CFG\_1[6:4] = “010” for negative pulse generation.

TRIGx\_CFG\_2[15:0] = Pulse width where each unit is 8 ns.

- Associate this Trigger Output Unit to a Specific GPIO Pin

TRIGx\_CFG\_1[3:0] = Selects GPIO pin to use.

- Set Up Interrupts, if Needed

If it is desired to get notification that the trigger output event occurred set up the following registers.

TRIGx\_CFG\_1, bit[8] (Trigger Notify) = “1” is one requirement for enabling interrupt on done or error.

Set the corresponding trigger Unit interrupt enable bit in the PTP\_TRIG\_IE register.



- Enabling the Trigger Output Unit

Set the corresponding trigger Unit enable bit in the TRIG\_EN register.

Be aware that for a low-going pulse in non-cascaded mode (single mode), the output will be driven by the unit to a high level when the trigger unit is enabled. In cascade mode, the output will be driven by the unit to the high state 8 ns prior to the programmed trigger time.

### 3.6.2 CREATING A HIGH-GOING PULSE AT A SPECIFIC TIME

- Specifying the Time

The desired trigger time will be set in TRIGx\_TGT\_NSH, TRIGx\_TGT\_NSL, TRIGx\_TGT\_SH, and TRIGx\_TGT\_SL registers.

- Specifying the Pulse Parameters

TRIGx\_CFG\_1[6:4] = "011" for positive pulse generation.

TRIGx\_CFG\_2[15:0] = Pulse width where each unit is 8 ns.

- Associate this Trigger Output Unit to a Specific GPIO Pin

TRIGx\_CFG\_1[3:0] = Selects GPIO pin to use.

- Set Up Interrupts if Needed

If it is desired to get notification that the trigger output event occurred set up the following registers.

TRIGx\_CFG\_1, bit[8] (Trigger Notify) = "1" is one requirement for enabling interrupt on done or error.

Set the corresponding trigger unit interrupt enable bit in the PTP\_TRIG\_IE register.

- Enabling the Trigger Output Unit

Set the corresponding trigger Unit enable bit in the TRIG\_EN register.

Be aware that for a high-going pulse in non-cascaded mode (single mode), the output will be driven by the unit to a low level when the trigger unit is enabled. In cascade mode, the output will be driven by the unit to the low state 8 ns prior to the programmed trigger time.

### 3.6.3 CREATING A FREE RUNNING CLOCK SOURCE

- Specifying the Time

Typically there is no need to set up a desired trigger time with respect to a free running clock. There are two ways that the free running clock can be started.

Set up a desired trigger time in the TRIGx\_TGT\_NSH, TRIGx\_TGT\_NSL, TRIGx\_TGT\_SH, and TRIGx\_TGT\_SL registers.

After parameters have been set up, start the clock by setting the Trigger Now bit, bit[9], in the TRIGx\_CFG\_1 register.

- Specifying the Clock Parameters

TRIGx\_CFG\_1[6:4] = "101" for generating a positive periodic signal.

High part of cycle defined by bits[15:0] in the TRIGx\_CFG\_2 register. Each unit is 8 ns.

Cycle width defined by bits[15:0] in TRIGx\_CFG\_3 and TRIGx\_CFG\_4 registers. Each unit is 1 ns.

Continuous clock by setting TRIGx\_CFG\_5, bits[15:0] = "0".

- Associate this Trigger Output Unit to a Specific GPIO Pin

TRIGx\_CFG\_1[3:0] = Selects GPIO pin to use.

- Set Up Interrupts if Needed

If it is desired to get notification that the trigger output event occurred set up the following registers.

TRIGx\_CFG\_1, bit[8] (Trigger Notify) = "1" is one requirement for enabling interrupt on done or error.

Set the corresponding trigger Unit interrupt enable bit in the PTP\_TRIG\_IE register.

- Enabling the Trigger Output Unit

Set the corresponding trigger Unit enable bit in the TRIG\_EN register.

# KSZ8441HL/FHL

---

Because the frequencies to be generated are based on the period of the 125 MHz clock, there are some limitations that the user must be aware of. Certain frequencies can be created with unvarying duty cycles. However, other frequencies may incur some variation in duty cycle. There are methods of utilizing the Trigger Unit 2 clock edge output select bit (bit[7] in of Reg. 0x248 – 0x249) and GPIO1 to control and minimize the variances.

## 3.6.4 CREATING FINITE LENGTH PERIODIC BIT STREAMS AT A SPECIFIC TIME

This example implies that a uniform clock will be generated for a specific number of clock cycles:

- Specifying the Time

The desired trigger time will be set in TRIGx\_TGT\_NSH, TRIGx\_TGT\_NSL, TRIGx\_TGT\_SH, and TRIGx\_TGT\_SL registers.

- Specifying the Finite Length Periodic Bit Stream Parameters

TRIGx\_CFG\_1[6:4] = “101” for generating a positive periodic signal.

High part of cycle defined by bits[15:0] in the TRIGx\_CFG\_2 register. Each Unit is 8 ns.

Cycle width defined by bits[15:0] in TRIGx\_CFG\_3 and TRIGx\_CFG\_4 registers. Each Unit is 1 ns.

Finite length count established by setting TRIGx\_CFG\_5, bits[15:0] = “number of cycles”. Each Unit is one cycle.

- Associate this Trigger Output Unit to a Specific GPIO Pin

TRIGx\_CFG\_1[3:0] = Selects GPIO pin to use.

- Set Up Interrupts if Needed

If it is desired to get notification that the trigger output event occurred, set up the following registers.

TRIGx\_CFG\_1, bit[8] (Trigger Notify) = “1” is one requirement for enabling interrupt on done or error.

Set the corresponding trigger Unit interrupt enable bit in the PTP\_TRIG\_IE register.

- Enabling the Trigger Output Unit

Set the corresponding Trigger Unit Enable bit in the TRIG\_EN register.

## 3.6.5 CREATING FINITE LENGTH NON-UNIFORM BIT STREAMS AT A SPECIFIC TIME

Generation of a finite length non-uniform waveform which is a multiple of the bit pattern stored in the data storage register.

- Specifying the Time

The desired trigger time will be set in TRIGx\_TGT\_NSH, TRIGx\_TGT\_NSL, TRIGx\_TGT\_SH, and TRIGx\_TGT\_SL registers.

- Specifying the Finite Length Non-Uniform Bit Stream Parameters

TRIGx\_CFG\_1[6:4] = “110” for generating signal based on contents of data register.

16-bit pattern stored in TRIGx\_CFG\_6 register.

Bit width defined by bits[15:0] in TRIGx\_CFG\_3 and TRIGx\_CFG\_4 registers. Each Unit is 1 ns.

Bit length of finite pattern is established by shifting the data register “N” times. Set TRIGx\_CFG\_5, bits[15:0] = “N”.

- Associate this Trigger Output Unit to a Specific GPIO Pin

TRIGx\_CFG\_1[3:0] = Selects GPIO pin to use.

- Set up Interrupts if Needed

If it is desired to get notification that the trigger output event occurred, set up the following registers.

TRIGx\_CFG\_1, bit[8] (Trigger Notify) = “1” is one requirement for enabling interrupt on done or error.

Set the corresponding trigger unit interrupt enable bit in the PTP\_TRIG\_IE register.

- Enabling the Trigger Output Unit

Set the corresponding trigger unit enable bit in the TRIG\_EN register.

## 3.6.6 CREATING COMPLEX WAVEFORMS AT A SPECIFIC TIME

Complex waveforms can be created by combining the various functions available in the trigger output units using a method called “cascading.”

Figure 3-12 illustrates the generation of a complex waveform onto one GPIO pin. Trigger output Unit 1 (TOU1) and trigger output Unit 2 (TOU2) are cascaded to produce the complex waveform. Cascading allows multiple outputs to be sequentially output onto one GPIO pin. In Figure 3-12, the waveform created by TOU1 is output first on the selected GPIO pin when the indicated TOU1 trigger time is reached. The value in TRIG1\_CFG7 and TRIG1\_CFG8 will be added to the TOU1 trigger time and the next TOU1 output will occur at that time. Meanwhile, TOU2, will operate in the same manner; outputting its waveform at TOU2 trigger time and then outputting again at a time TRIG2\_CFG7 and TRIG2\_CFG8 later. The TRIGx\_CFG7 and 8 register values must be the same for all TOUs that are cascaded together. The number of times TOU1 and TOU2 will be output will depend on the cycle times programmed into the TRIG1\_CFG6 and TRIG2\_CFG6 registers. Care must be taken to select the correct values so as to avoid erroneous overlap.

Additional steps are required in setting up cascaded TOUs:

- Specifying which trigger output Unit in the cascade is the last Unit called the tail unit.
- The last trigger output Unit in a cascade setup should have its tail bit set to “1”.

**FIGURE 3-12: COMPLEX WAVEFORM GENERATION USING CASCADE MODE**

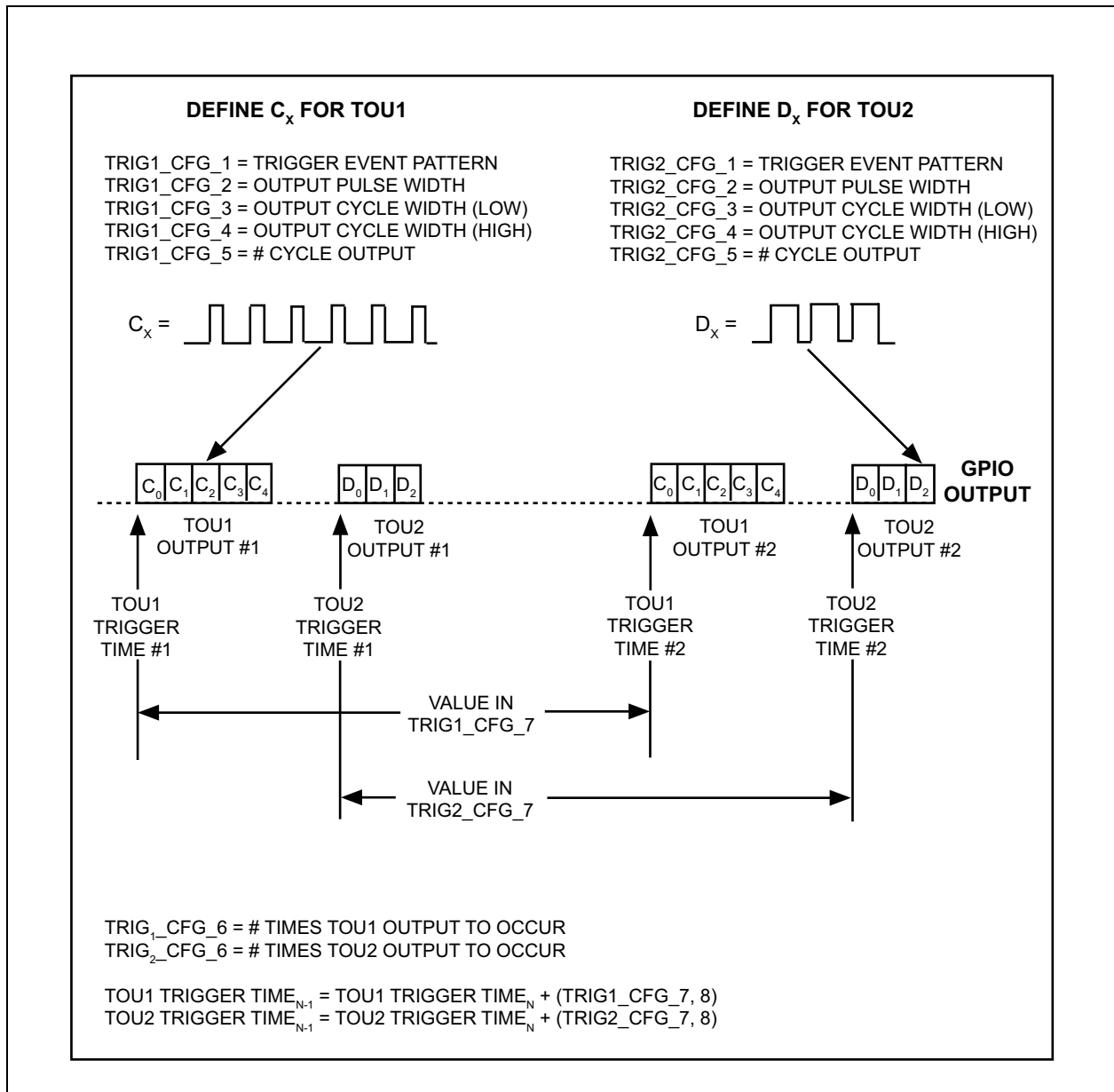

# KSZ8441HL/FHL

---

## 3.7 Using the GPIO Pins with the Time Stamp Input Units

The twelve time stamp input units (TSU) can be set up to capture a variety of inputs at user selectable GPIO pins. The current time of the precision time clock time will be captured and stored at the time in which the input event occurs. This section provides some information on configuring the time stamp input units. In the information below, the value “x” represents one of the twelve time stamp input units. Because this area of the device is very flexible and powerful, it is advised that you contact your Microchip representative for additional information on capturing specific types of waveforms and utilizing this feature.

### 3.7.1 TIME STAMP VALUE

Each time stamp unit can capture two sampled values of time stamps before the values are overwritten. These first two values remain until read, even if more events occur. The time stamp value captured consists of three parts which are latched in three registers.

Sample #1, the seconds value; TSx\_SMPL1\_SH, TSx\_SMPL1\_SL

Sample #1, the nanoseconds value; TSx\_SMPL1\_NSH, TSx\_SMPL1\_NSL

Sample #1, the sub-nanoseconds value; TSx\_SMPL1\_SUB\_NS

Sample #2, the seconds value; TSx\_SMPL2\_SH, TSx\_SMPL2\_SL

Sample #2, the nanoseconds value; TSx\_SMPL2\_NSH, TSx\_SMPL2\_NSL

Sample #2, the sub-nanoseconds value; TSx\_SMPL2\_SUB\_NS

The actual value in TSx\_SMPL1/2\_SUB\_NS is a binary value of 0 through 4 which indicates 0 ns, 8 ns, 16 ns, 24 ns, or 32 ns. Note that the processor needs to add this value to the seconds and nanoseconds value to get the closest true value of the time stamp event.

- Number of Time Stamps Available

Each time stamp input unit can capture two events or two time stamps values. Note that the exception to this is TSU12. TSU12 can capture eight events and thus has eight sample time registers (SMPL1 through SMPL8) allowing for more robust timing acquisition in one TSU. Note that the amount of samples for any given GPIO pin can be increased by cascading time stamp unit. When TSUs are cascaded, the incoming events are routed to a sequentially established order of TSUs for capture. For example, you can cascade TSU12, and TSU 1-4 to be able to capture twelve time stamps off of one GPIO pin. Cascading is set up in the TSx\_CFG registers.

- Events that can be Captured

The time stamp input units can capture rising edges and falling edges. In this case, the time stamp of the event will be captured in the Sample #1 time stamp registers. A pulse can be captured if rising edge detection is combined with falling edge detection. In this case, one edge will be captured in the Sample #1 time stamp registers and the other edge will be captured in the Sample #2 time stamp registers. This functionality is programmed in the TSx\_CFG register for each time stamp unit.

### 3.7.2 TIME STAMPING AN INCOMING LOW-GOING EDGE

- Specifying the Edge Parameters

TSx\_CFG bit[6] = “1”

- Associate this Time Stamp Unit to a Specific GPIO Pin

TSx\_CFG bits[11:8] = Selected GPIO Pin #

- Set Up Interrupts if Needed

Set the corresponding time stamp unit interrupt enable bit in the PTP\_TS\_IE register.

- Enabling the Time Stamp Unit

Set the corresponding time stamp unit enable bit in the TS\_EN register.

### 3.7.3 TIME STAMPING AN INCOMING HIGH-GOING EDGE

- Specifying the Edge Parameters

TSx\_CFG bit[7] = “1”

- Associate this Time Stamp Unit to a Specific GPIO Pin

TSx\_CFG bits[11:8] = Selected GPIO Pin #

- Set Up Interrupts if Needed

Set the corresponding time stamp unit interrupt enable bit in the PTP\_TS\_IE register.

- Enabling the Time Stamp Unit

Set the corresponding time stamp unit enable bit in the TS\_EN register.

### 3.7.4 TIME STAMPING AN INCOMING LOW-GOING PULSE OR HIGH-GOING PULSE

- Specifying the Edge Parameters

TSx\_CFG bit[7] = “1”

TSx\_CFG bit[6] = “1”

- Associate this Time Stamp Unit to a Specific GPIO Pin

TSx\_CFG bits[11:8] = Selected GPIO Pin Number

- Set Up Interrupts if Needed

Set the corresponding time stamp unit interrupt enable bit in the PTP\_TS\_IE register.

- Enabling the Time Stamp Unit

Set the corresponding time stamp unit enable bit in the TS\_EN register.

## 3.8 Device Clocks

A 25 MHz crystal or oscillator clock is required to operate the device. This clock is used as input to a PLL clock synthesizer which generates various clocks for the KSZ8441 system timing. [Table 3-12](#) summarizes the clocking.

**TABLE 3-12: DEVICE CLOCKS AND RELATED PINS**

Clock	Usage	Source	Strapping Option
25 MHz	Used for general system internal clocking. Used to generate an internal 125 MHz clock for the IEEE 1588 block.	A 25 MHz crystal connected between pins X1 and X2. or A 25 MHz oscillator that is connected to only the X1 pin. The X2 pin is left unconnected.	None
SEEPROM	Used to clock data to or from the Serial EEPROM.	2.5 MHz, divided down from the 25 MHz input clock. This is H/W generated only during the access immediately following reset. Can also be software generated via Register 0x122 – 0x123 (EEPCCR). After reset time, this is the only way to generate the clock to the Serial EEPROM for access.	None

Note that the clock tree power-down control register (0x038 – 0x039): CTPDC is used to power down the clocks in various areas of the device. There are no other internal register bits that control the clock generation or usage in the device.

### 3.8.1 GPIO AND IEEE 1588-RELATED CLOCKING

The GPIO and IEEE 1588-related circuits both utilize the 25 MHz clock and the derived 125 MHz clock. The tolerance and accuracy of the 25 MHz clock source will affect the IEEE 1588 jitter and offset in a system utilizing multiple slave devices. Therefore, the 25 MHz source should be chosen with care towards the performance of the application in mind. Using an oscillator will generally provide better results.

## 3.9 Power

The KSZ8441 device requires a single 3.3V supply to operate. An optional internal low-voltage LDO provides the necessary low voltage (nominal ~1.3V) to power the analog and digital logic cores. The various I/Os can be operated at 1.8V, 2.5V, and 3.3V. [Table 3-13](#) illustrates the various voltage options and requirements of the device.

# KSZ8441HL/FHL

**TABLE 3-13: VOLTAGE OPTIONS AND REQUIREMENTS**

Power Signal Name	Device Pin	Requirement
VDD_A3.3	9	3.3V input power to the analog blocks in the device.
VDD_IO	21, 30, 56	Choice of 1.8V or 2.5V or 3.3V for the I/O circuits. These input power pins power the I/O circuitry of the device. This voltage is also used as the input to the internal low-voltage regulator.
VDD_AL	6	Filtered low-voltage analog input voltage. This is where the filtered low voltage is fed back into the device to power the analog block.
VDD_COL	16	Filtered low-voltage AD input voltage. This pin feeds the low voltage to the digital circuits within the analog block.
VDD_L	40, 51	Output of internal low-voltage LDO regulator. This voltage is available on these pins to allow connection to external capacitors and ferrite beads for filtering and power integrity. These pins must be externally connected to pins 6 and 16.  If the internal LDO regulator is turned off, these pins become power inputs.
AGND	3, 8, 12	Analog Ground.
DGND	20, 29, 39, 50, 57	Digital Ground.

The preferred method of configuring the related low-voltage power pins when using an external low-voltage regulator is illustrated in [Figure 3-13](#). The number of capacitors, values of capacitors, and exact placement of components will depend upon the specific design.

**FIGURE 3-13: RECOMMENDED LOW-VOLTAGE POWER CONNECTION USING AN EXTERNAL LOW-VOLTAGE REGULATOR**

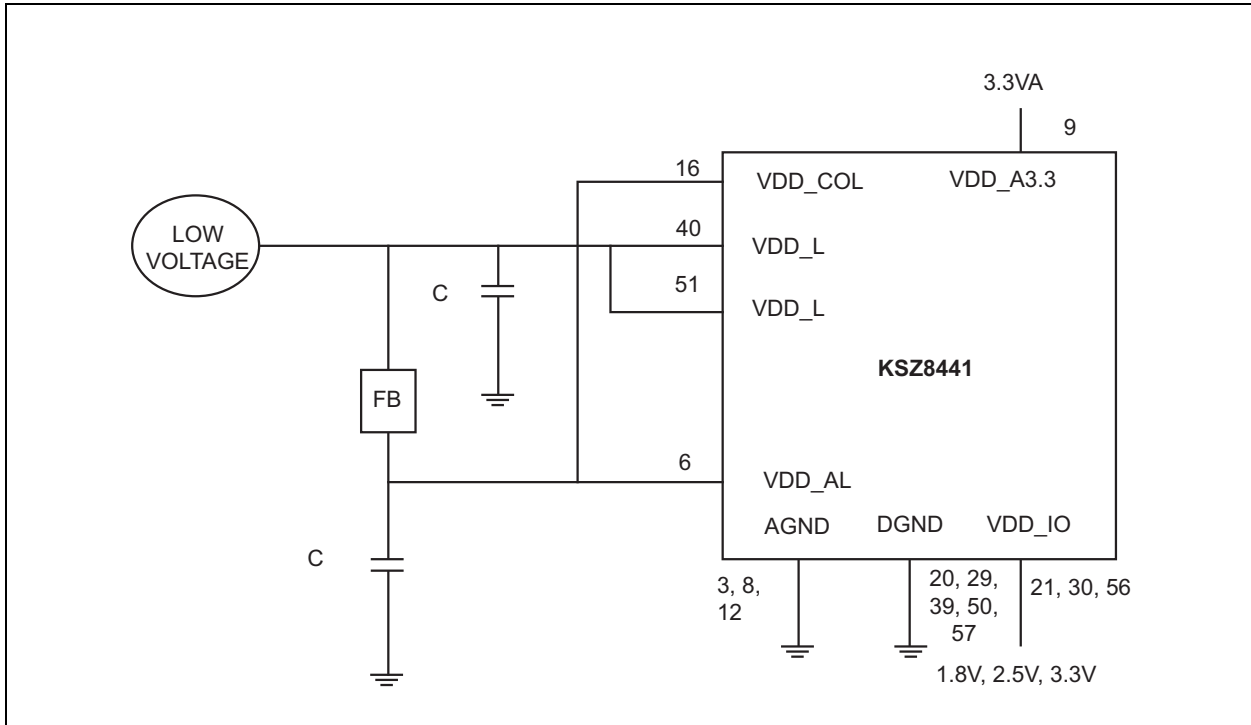

## 3.9.1 INTERNAL LOW VOLTAGE LDO REGULATOR

The KSZ8441 reduces board cost and simplifies board layout by integrating a low noise internal low-voltage LDO regulator to supply the nominal ~1.3V core power voltage for a single 3.3V power supply solution. If it is desired to take advantage of an external low-voltage supply that is available, the internal low-voltage regulator can be disabled to save power. The LDO\_Off bit, bit[7] in Register 0x748 is used to enable or disable the internal low-voltage regulator. The default state of the LDO\_Off bit is "0" which enables the internal low-voltage regulator. Turning off the internal low-voltage regulator will require software to write a "1" to that control bit. During the time from power up to setting this bit, both the external voltage supply and the internal regulator will be supplying power. Note that it is not necessary to turn off the internal low-voltage regulator. No damage will occur if it is left on. However, leaving it on will result in less than optimized power consumption.

The internal regulator takes its power from VDD\_IO, and functions best when VDD\_IO is 3.3V or 2.5V. If VDD\_IO is 1.8V, the output voltage will be somewhat decreased. For optimal performance, an external power supply, in place of the internal regulator, is recommended when VDD\_IO is 1.8V.

The preferred method of configuring the low-voltage related power pins for using the internal low-voltage regulator is illustrated in [Figure 3-14](#). The output of the internal regulator is available on pins 40 and 51 and is filtered using external capacitors and a ferrite bead to supply power to pins 6 and 16. The number of capacitors, values of capacitors, and exact placement of components will depend upon the specific design.

**FIGURE 3-14: RECOMMENDED LOW-VOLTAGE POWER CONNECTION USING THE INTERNAL LOW-VOLTAGE REGULATOR**

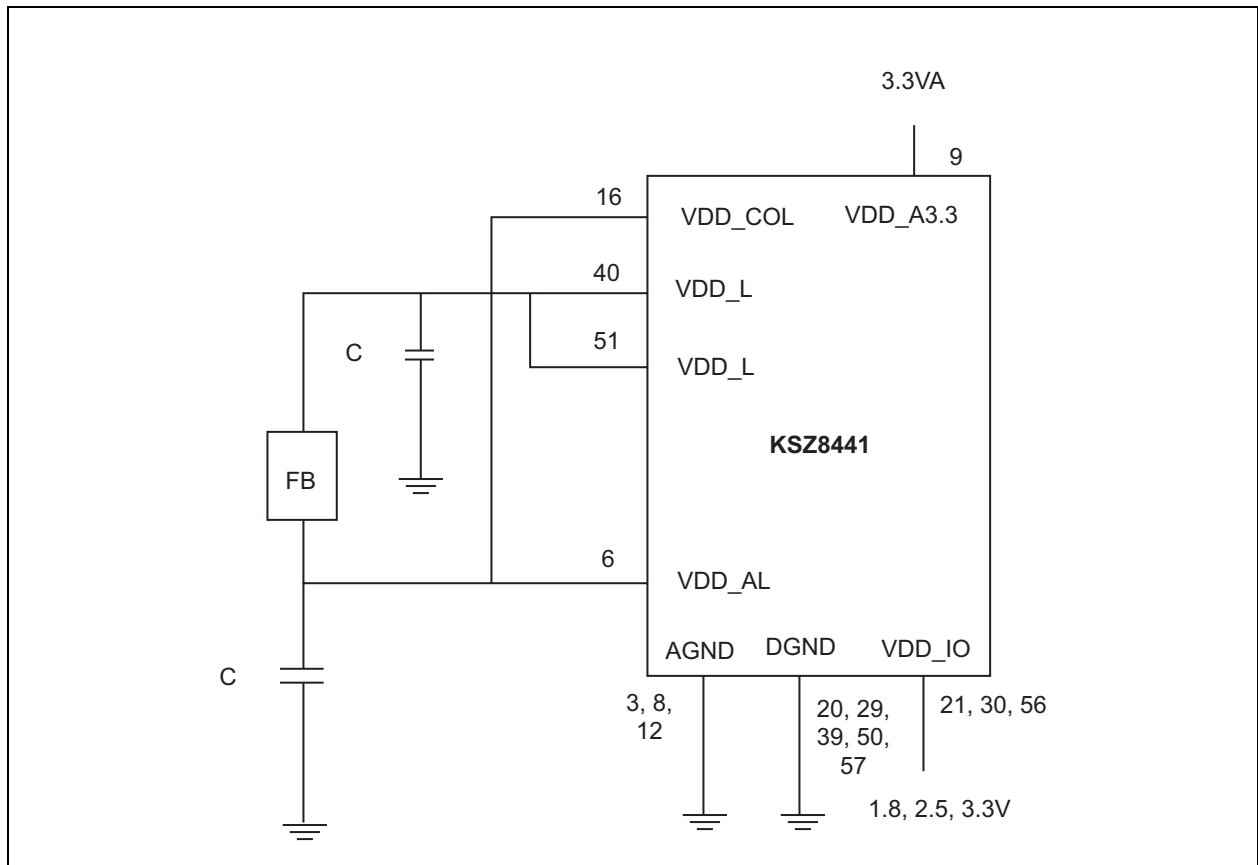

# KSZ8441HL/FHL

## 3.10 Power Management

The KSZ8441 supports enhanced power management features in low-power state with energy detection to ensure low-power dissipation during device idle periods. There are three operation modes under the power management function which is controlled by two bits in the power management control and wake-up event status register (PMCTRL, 0x032 – 0x033) as shown below:

- PMCTRL[1:0] = “00” Normal Operation Mode
- PMCTRL[1:0] = “01” Energy Detect Mode
- PMCTRL[1:0] = “10” Global Soft Power-Down Mode

The [Table 3-14](#) indicates all internal function blocks status under three different power-management operation modes.

**TABLE 3-14: POWER MANAGEMENT AND INTERNAL BLOCKS**

KSZ8441 Function Blocks	Power Management Operation Modes		
	Normal Mode	Energy Detect Mode	Soft Power-Down Mode
Internal PLL Clock	Enabled	Disabled	Disabled
Tx/Rx PHYs	Enabled	Energy Detect at Rx	Disabled
MACs	Enabled	Disabled	Disabled
Host Interface	Enabled	Disabled	Disabled

### 3.10.1 NORMAL OPERATION MODE

Normal operation mode is the power management mode entered into after device power-up or after hardware reset pin 63. It is established via bits[1:0] = “00” in the PMCTRL register. When the KSZ8441 is in normal operation mode, all PLL clocks are running, PHYs and MACs are on, and the CPU is ready to read or write the KSZ8441 through host interface.

During the normal operation mode, the host CPU can change the power management mode bits[1:0] in the PMCTRL register to transition to another desired power management mode

### 3.10.2 ENERGY-DETECT MODE

Energy detect mode provides a mechanism to save more power than in normal operation mode when the cable is not connected to an active link partner. For example, if the cable is not present or it is connected to a powered-down partner, the KSZ8441 can automatically enter the low power state in energy detect mode. Once activity resumes after attaching a cable or by a link partner attempting to establish a link, the KSZ8441 will automatically power up into the normal power state in energy detect normal power state. The energy detect mode function is not valid in fiber mode using the KSZ8441FHL.

Energy detect mode consists of two states, normal power state and low power state. While in low-power state, the KSZ8441 reduces power consumption by disabling all circuitry except the energy detect circuitry of the receiver. Energy detect mode is enabled by setting bits[1:0] = “01” in the PMCTRL register. When the KSZ8441 is in this mode, it will monitor the cable energy. If there is no energy on the cable for a time longer than a pre-configured value determined by bits[7:0] (go-sleep time) in the GST register, the device will go into the low power state. When the KSZ8441 is in low power state, it will keep monitoring the cable energy. Once energy is detected from the cable and is present for a time longer than 100 ns, the KSZ8441 will enter the normal power state.

The KSZ8441 will assert the PME output pin if the corresponding enable bit[0] is set in the PMEE register (0x034) or generate an interrupt to signal that an energy detect event has occurred if the corresponding enable bit[2] is set in the IER register (0x190). Once the local power management unit detects the PME output is asserted or that the interrupt is active, it will power up the host processor and issue a wake-up command which is a read cycle to read the globe reset register, GRR (0x126) to wake up the KSZ8441 from the low power state to the normal power state. When the KSZ8441 device is in the normal power state, it is able to transmit or receive packet from the cable.

### 3.10.3 GLOBAL SOFT POWER-DOWN MODE

Soft power-down mode is entered by setting bits[1:0] = “10” in PMCTRL register. When the device is in this mode, all PLL clocks are disabled, the PHYs and the MACs are off, all internal registers value will change to their default value (except the BIU, QMU registers), and the host interface is only used to wake-up this device from the current soft power-down mode to normal operation mode by setting bits[1:0] = “00” in the PMCTRL register.

Note that the registers within the QMU block will not be changed to their default values when a soft power-down is issued. All strapping pins are sampled to latch any new values when soft power-down is disabled.



### 3.10.4 ENERGY EFFICIENT ETHERNET (EEE)

Energy Efficient Ethernet (EEE) is implemented in the KSZ8441 device as described in the IEEE 802.3AZ specification for MII operations on Port 1. The EEE function is not available for fiber mode ports using the KSZ8441FHL. The internal MII connection between the MAC and PHY blocks are internal to the chip and are not visible to the user. The standards are defined around a MAC that supports special signaling associated with EEE. EEE saves power by keeping the voltage on the Ethernet cable at approximately 0V for as often as possible during periods of no traffic activity. This is called low-power idle state (LPI). However, the link will respond automatically when traffic resumes and do so in such a way as to not cause blocking or dropping of any packets. (The wake up time for 100BASE-TX is specified to be less than 30  $\mu$ s.) The transmit and receive directions are independently controlled. Note the EEE is not specified or implemented for 10BASE-T. In 10BASE-T, the transmitter is already OFF during idle periods.

The EEE feature is enabled by default. EEE is auto-negotiated independently for each direction on a link, and is enabled only if both nodes on a link support it. To disable EEE, clear the Next Page Enable bit in the PCSEEEEC register (0x0F3) and restart auto-negotiation.

Based on the EEE specification, the energy savings from EEE is occurs at the PHY level. However, the KSZ8441 reduces the power consumption not only in the PHY block but also in the MAC block by shutting down any unused clocks as much as possible when the device is at Low-Power Idle state. A comprehensive LPI request on/off policy is also built-in at the switch level to determine when to issue LPI requests and when to stop the LPI request. Some software control options are provided in the device to terminate the LPI request in the early phase when certain events occur to reduce the latency impact during LPI recovery. A configurable LPI recovery time register is provided at each port to specify the recovery time (25  $\mu$ s at default) required for the KSZ8441 and its link partner before they are ready to transmit and receive a packet after going back to the normal state. For details, refer the KSZ8441 EEE registers (0x0E0 – 0x0F7) description.

The time during which LPI mode is active is during what is called quiet time. This is shown in [Figure 3-15](#).

**FIGURE 3-15: TRAFFIC ACTIVITY AND EEE**

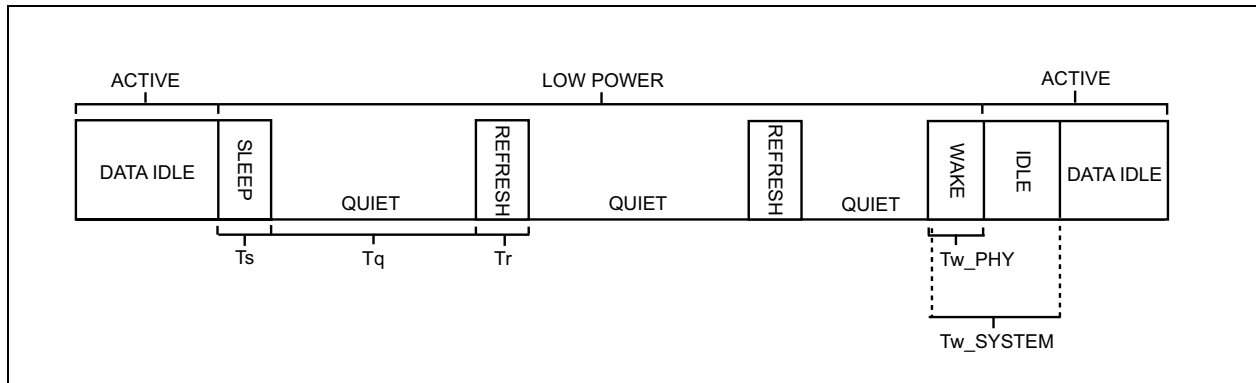

### 3.10.5 TRANSMIT DIRECTION CONTROL FOR MII MODE

Low-power idle (LPI) state for the transmit direction will be entered when the internal EEE MAC signals to its PHY to do so. The PHY will stay in the transmit LPI state as long as indicated by the MAC. The TX\_CLK is not stopped.

Even though the PHY is in LPI state, it will periodically leave the LPI state to transmit a refresh signal using specific transmit code bits. This allows the link partner to keep track of the long-term variation of channel characteristics and clock drift between the two partners. Approximately every 20 ms – 22 ms, the PHY will transmit a bit pattern to its link partner of duration 200  $\mu$ s – 220  $\mu$ s. The refresh times are listed in [Figure 3-15](#).

### 3.10.6 RECEIVE DIRECTION CONTROL FOR MII MODE

If enabled for LPI mode, upon receiving a P Code bit pattern (refresh), the PHY will enter the LPI state and signal to the internal MAC. If the PHY receives some non-P Code bit pattern, it will signal to the MAC to return to “normal frame” mode. The PHY can turn off the RX\_CLK after nine or more clocks have occurred in the LPI state.

In the EEE-compliant environment, the internal PHYs will be monitoring and expecting the P Code (refresh) bit pattern from its link partner that is generated approximately every 20 ms – 22 ms, with a duration of about 200  $\mu$ s – 220  $\mu$ s. This allows the link partner to keep track of the long term variation of channel characteristics and clock drift between the two partners.

# KSZ8441HL/FHL

---

## 3.10.7 REGISTERS ASSOCIATED WITH EEE

The following registers are used to configure or manage the EEE feature:

- Reg. DCh, DDh – P1ANPT – Port 1 Auto-Negotiation Next Page Transmit Register
- Reg. DEh, DFh – P1ALPRNP – Port 1 Auto-Negotiation Link Partner Received Next Page Register
- Reg. E0h, E1h – P1EEEE – Port 1 EEE and Link Partner Advertisement Register
- Reg. E2h, E3h – P1EEEWEC – Port 1 EEE Wake Error Count Register
- Reg. E4h, E5h – P1EEEECS – Port 1 EEE Control/Status and Auto-Negotiation Expansion Register
- Reg. E6h – P1LPIRTC – Port 1 LPI Recovery Time Counter Register
- Reg. E7h – BL2LPIC1 – Buffer Load to LPI Control 1 Register
- Reg. F3h – PCSEEEEC – PCS EEE Control Register
- Reg. F4h, F5h – ETLWTC – Empty TXQ to LPI Wait Time Control Register

## 3.10.8 WAKE-ON-LAN

Wake-on-LAN is considered a power-management feature in that it can be used to communicate to a specific network device and tell it to “wake up” from sleep mode and be prepared to transfer data. The KSZ8441 can be programmed to notify the host of the Wake-Up detected condition. It does so by assertion of the interrupt signal pin (INTRN) or the power management event signal pin (PME). A wake-up event is a request for hardware and/or software external to the network device to put the system into a powered state (working). There are four events that will trigger the Wake-Up interrupt to occur. They are:

1. Detection of an energy signal over a pre-configured value (Indicated by bit[2] in the ISR register being set)
2. Detection of a linkup in the network link state (Indicated by bit[3] in the ISR register being set)
3. Receipt of a Magic Packet (Indicated by bit[4] in the ISR register being set)
4. Receipt of a network Wake-Up frame (Indicated by bit[5] in the ISR register being set)

There are also other types of wake-up events that are not listed here as manufacturers may choose to implement these in their own way.

### 3.10.8.1 Direction of Energy

The energy is detected from the cable and is continuously presented for a time longer than pre-configured value, especially when this energy change may impact the level at which the system should re-enter to the normal power state.

### 3.10.8.2 Detection of Linkup

Link status wake events are useful to indicate a linkup in the network's connectivity status.

### 3.10.8.3 Wake-Up Packet

Wake-up packets are certain types of packets with specific CRC values that a system recognizes as a ‘Wake-Up’ frame. The KSZ8441 supports up to four user defined wake-up frames shown below:

- Wake-up frame 0 is defined in Wake-Up frame registers (0x130 – 0x13B) and is enabled by bit [0] in the Wake-Up frame register (0x12A).
- Wake-up frame 1 is defined in wake-up frame registers (0x140 – 0x14B) and is enabled by bit [1] in the Wake-Up frame register (0x12A).
- Wake-up frame 2 is defined in wake-up frame registers (0x150 – 0x15B) and is enabled by bit [2] in the Wake-Up frame register (0x12A).
- Wake-up frame 3 is defined in wake-up frame registers (0x160 – 0x16B) and is enabled by bit [3] in the Wake-Up frame register (0x12A).

### 3.10.8.4 Magic Packet™

Magic Packet (MP) technology is used to remotely wake up a sleeping or powered-off PC on a LAN. This is accomplished by sending a specific packet of information, called an MP frame, to a node on the network. When a PC capable of receiving the specific frame goes to sleep, it enables the MP RX mode in the LAN controller, and when the LAN controller receives a MP frame, the LAN controller will alert the system to wake up.

MP is a standard feature integrated into the KSZ8441. The controller implements multiple advanced power-down modes including MP to conserve power and operate more efficiently. Once the KSZ8441 has been put into MP enable mode (WFCR[7] = “1”), it scans all incoming frames addressed to the node for a specific data sequence, which indicates to the controller this is a MP frame.

The specific sequence consists of 16 duplications of the IEEE address of this node, with no breaks or interruptions. This sequence can be located anywhere within the packet, but must be preceded by a synchronization stream. The synchronization stream allows the scanning state machine to be much simpler. The synchronization stream is defined as 6 bytes of FFh. The device will also accept a broadcast frame, as long as the 16 duplications of the IEEE address match the address of the machine to be awakened.

Example:

If the IEEE address for a particular node on a network is 11h 22h, 33h, 44h, 55h, 66h, the LAN controller would be scanning for the data sequence (assuming an Ethernet frame):

```
DESTINATION SOURCE – MISC - FF FF FF FF FF FF - 11 22 33 44 55 66 - 11 22 33 44 55 66 - 11 22 33 44 55 66 -  
11 22 33 44 55 66 - 11 22 33 44 55 66 - 11 22 33 44 55 66 - 11 22 33 44 55 66 - 11 22 33 44 55 66 -  
-11 22 33 44 55 66 - 11 22 33 44 55 66 - 11 22 33 44 55 66 - 11 22 33 44 55 66 - 11 22 33 44 55 66 -  
- 11 22 33 44 55 66 - MISC - CRC.
```

There are no further restrictions on an MP frame. For example, the sequence could be in a TCP/IP packet or an IPX packet. The frame may be bridged or routed across the network without affecting its ability to wake-up a node at the frame’s destination.

If the LAN controller scans a frame and does not find the specific sequence shown above, it discards the frame and takes no further action. If the KSZ8441 controller detects the data sequence, however, it then alerts the PC’s power management circuitry (assert the PME pin) to wake up the system.

### 3.10.9 INTERRUPT GENERATION ON POWER MANAGEMENT-RELATED EVENTS

There are two ways an interrupt can be generated to the host whenever a power management related event takes place. The resulting interrupts are via the PME signal pin or via the INTRN signal pin. The usage is described in the following sub-sections:

#### 3.10.9.1 To Generate an Interrupt on the PME Signal Pin

The PMEE register (0x034 – 0x035) contains the bits needed to control generating an interrupt on the PME signal pin whenever specific power management related events occur. The power management events controlled by this register includes detection of a Wake-Up frame, detection of a MP, detection that the link has changed state, and detection of energy on the Ethernet lines.

#### 3.10.9.2 To Generate an Interrupt on the INTRN Signal Pin

The IER register (0x190 – 0x191) contains the bits needed to control generating an interrupt on the INTRN signal pin whenever specific power management related events occur. The power management events controlled by this register includes detection of a wake-up from a link state change and wake-up from detection of energy on the Ethernet lines.

## 3.11 Interfaces

The KSZ8441 device incorporates a number of interfaces to enable it to be designed into a standard network environment as well as a vendor unique environment. The available interfaces and details of each usage are provided in [Table 3-15](#).

# KSZ8441HL/FHL

**TABLE 3-15: AVAILABLE INTERFACES**

Interface	Type	Usage	Registers Accessed
Host Bus	Configuration and Data Flow	Provides a path for network data to be transferred to and from the host processor. Provides in-band communication between a host processor and the KSZ8441 device for configuration, control, and monitoring.	All
Serial EEPROM	Configuration and Register Access	Device can access the Serial EEPROM to load the MAC Address at power-up. In addition, the remainder of EEPROM space can be written or read and used as needed by the host.	110h - 115h
PHY	Data Flow	Interface to the two internal PHY devices.	N/A

## 3.11.1 BUS INTERFACE UNIT (BIU)/HOST INTERFACE

The BIU manages the host interface which is a generic indirect data bus interface, and is designed to communicate with embedded processors. Typically, no glue logic is required when interfacing to standard asynchronous buses and processors.

### 3.11.1.1 Supported Transfers

The BIU can support asynchronous transfers in SRAM-like slave mode. To support the data transfers, the BIU provides a group of signals as shown in [Table 3-16](#). These signals are SD[15:0], CMD, CSN, RDN, WRN, and INTRN. Note that it is intended that the CSN signal be driven by logic within the host processor or by some external logic which decode the base address so the KSZ8441 device does not have to do address range decoding.

### 3.11.1.2 Physical Data Bus Size

The BIU supports an 8-bit or 16-bit host standard data bus. Depending on the size of the physical data bus, the KSZ8441 can support 8-bit or 16-bit data transfers.

For a 16-bit data bus mode, the KSZ8441 allows an 8-bit and 16-bit data transfer.

For an 8-bit data bus mode, the KSZ8441 only allows an 8-bit data transfer.

The KSZ8441 supports internal data byte-swapping. This means that the system/host data bus HD[7:0] connects to SD[7:0] for an 8-bit data bus interface. For a 16-bit data bus, the system/host data bus HD[15:8] and HD[7:0] connects to SD[15:8] and SD[7:0] respectively.

**TABLE 3-16: BUS INTERFACE UNIT SIGNAL GROUPING**

Signal	Type	Function
SD[15:0]	I/O	<b>Shared Data Bus</b> <ul style="list-style-type: none"> <li>• 16-bit Mode &amp; CMD = "0" <ul style="list-style-type: none"> <li>- SD[15:0] = D[15:0] data</li> </ul> </li> <li>• 16-bit Mode &amp; CMD = "1": <ul style="list-style-type: none"> <li>- SD[10:2] = A[10:2] Address</li> <li>- SD[15:12] = BE[3:0] Byte enable</li> <li>- SD[1:0] and SD[11] are not used</li> </ul> </li> <li>• 8-bit Mode &amp; CMD = "0" <ul style="list-style-type: none"> <li>- SD[7:0] = D[7:0] data</li> </ul> </li> <li>• 8-bit Mode &amp; CMD = "1" <ul style="list-style-type: none"> <li>- SD[7:0] = A[7:0] = 1st address access</li> <li>- SD[2:0] = A[10:8] = 2nd address access</li> <li>- SD[7:3] = Not used during 2nd address access</li> </ul> </li> </ul>
CMD	Input	<b>Command Type</b> This command input determines the SD[15:0] shared data bus access cycle information. 0: Data access 1: Command access for address and byte enable

**TABLE 3-16: BUS INTERFACE UNIT SIGNAL GROUPING (CONTINUED)**

Signal	Type	Function
CSN	Input	<b>Chip Select</b> Chip Select is an active-low signal used to enable the shared data bus access.
INTRN	Output	<b>Interrupt</b> This low active signal is asserted low when an interrupt is being requested.
RDN	Input	<b>Asynchronous Read</b> This low active signal is asserted low during a read cycle. A 4.7 kΩ pull-up resistor is recommended on this signal.
WRN	Input	<b>Asynchronous Write</b> This low active signal is asserted low during a write cycle.

### 3.11.1.3 Little- and Big-Endian Support

The KSZ8441 supports either Little-Endian or Big-Endian processors. The external strap pin 62 (LEBE) is used to select between the two modes. The KSZ8441 host interface operates in Little-Endian mode if this pin is pulled up during reset, or in Big-Endian mode if this pin is pulled down during reset. If there is no external load on pin 62 during reset, it will be pulled up by its internal pull-up resistor, placing the interface into Little-Endian mode.

Bit [11] (Endian mode selection) in RXFDPR register can be used to program either Little-Endian mode (bit [11] = “0”) or Big-Endian mode (bit [11] = “1”). Changes to this register bit will override the pin 62 strap-in selection. Software in the host processor must take care to avoid unintentionally changing bit [11] when writing to register RXFDPR.

### 3.11.1.4 Asynchronous Interface

For asynchronous transfers, the asynchronous interface uses RDN (read) or WRN (write) signal strobe for data latching. The host utilizes the rising edge of RDN to latch read data and the KSZ8441 will use the falling edge of WRN to latch write data.

All asynchronous transfers are either single-data or burst-data transfers. Byte or word data bus access (transfers) is supported. The BIU, however, provides flexible asynchronous interfacing to communicate with various applications and architectures. No additional address latch is required. The BIU qualifies both chip select (CSN) pin and write enable (WRN) pin to write the Address A[10:2] and BE[3:0] value (in 16-bit mode) or Address A[10:0] value (in 8-bit mode with two write accesses) into KSZ8441 when CMD (Command type) pin is high. The BIU qualifies the CSN pin as well as the read enable (RDN) or write enable (WRN) pin to read or write the SD[15:0] (16-bit mode) or SD[7:0] (8-bit mode) data value from or to KSZ8441 when command type (CMD) pin is low.

In order for software to read back the previous CMD register write value when CMD is “1”, the BIU qualifies both the CSN pin and the RDN pin to read the Address A[10:2] and BE[3:0] value (in 16-bit mode) back from the KSZ8441 when CMD pin is high. Reading back the addresses in 8-bit mode is not a valid operation.

### 3.11.1.5 BIU Summary

Figure 3-16 shows the connection for different data bus sizes.

All of control and status registers in the KSZ8441 are accessed indirectly depending on CMD pin. The command sequence to access the specified control or status register is to write the register’s address (when CMD = “1”) then read or write this register data (when CMD = “0”). If both RDN and WRN signals in the system are only used for KSZ8441, the CSN pin can be forced to active low to simplify the system design. The CMD pin can be connected to host address line HA[0] for 8-bit bus mode or HA[1] for 16-bit bus mode.

# KSZ8441HL/FHL

FIGURE 3-16: KSZ8441 8-BIT AND 16-BIT DATA BUS CONNECTIONS

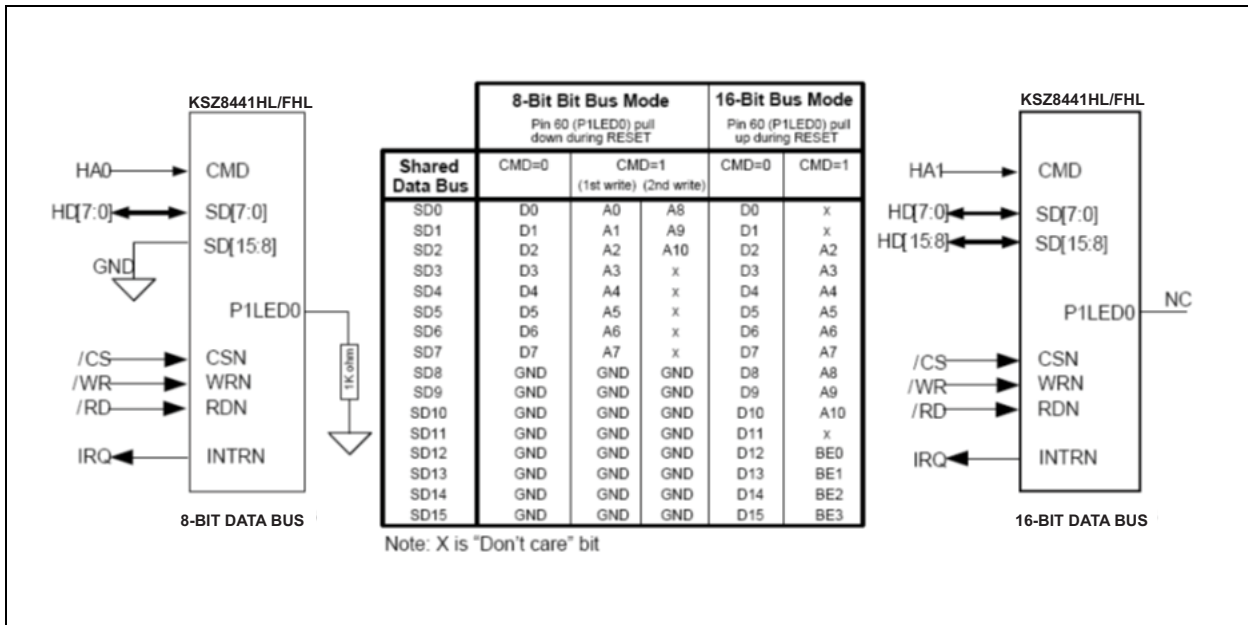

Example:

Assume that the register space is located at an external I/O base address of 0x0300, a 16-bit data path is used, and it is desired to read two bytes of data from address 0xD0:

- External address decoding should decode the 0x0300 base address and create a signal for the CSN pin.
- The host address line 1 (HA[1]) is connected to the CMD input pin. For a host write to the device, the HA[1] being asserted will make CMD = "1" which will indicate that the data on the DS[15:0] bus are address and byte enable bits.
- The address bits A[10:2] are on SD[10:2].
- Write a value of 0x30D0 (register offset of 0xD0 with BE[1:0] (set on the SD[16:0] bus) to address 0x0302. (This sets up the address for the upcoming read operation by writing the desired destination address to be read.)
- Read the value from address 0x0300 with HA[1] = 0 (CMD = "0"). The CSN pin is driven again by the decode of the base address of 0x0300.

### 3.11.2 SERIAL EEPROM INTERFACE

A serial EEPROM interface has been incorporated into the device to enable loading the MAC address into the device at power-up time with a value from an external serial EEPROM. This feature is turned on using a strapping option on pin 46. At power-up time, the voltage on pin 46 is sampled. If the voltage is found to be high, the first seven words of the serial EEPROM will be read. Registers 0x110 – 0x115 will be loaded with words 01h – 03h.

A pull-up resistor is connected to pin 46 to create a high state at power-up time (see Table 2-2). After the de-assertion of RSTN, the KSZ8441 reads in the seven words of data. Note that a 3-wire 1 Kbit serial EEPROM utilizing 7-bit addresses must be used. Other size options will not function correctly. A 93C46 or equivalent type device meets these requirements. The EEPROM must be organized in 16-bit mode.

The serial EEPROM interface signals are muxed with three of the GPIO signals on pins 53, 54, and 55. Register 0x0D6 – 0x0D7 bits[1, 2, 5] are used to select between the serial EEPROM function or the GPIO function. The default state of that register at power up is to configure the pins for serial EEPROM usage.

If the EEDIO pin (pin 54) is pulled high, then the KSZ8441 performs an automatic read of words 0h - 6h in the external EEPROM after the de-assertion of reset. The EEPROM values are placed in certain host-accessible registers. EEPROM read/write functions can also be performed by software read/writes to the EEPCR (0x122) registers.

A sample of the KSZ8441 EEPROM format is shown in Table 3-17.

**TABLE 3-17: SERIAL EEPROM FORMAT**

Word	15:8	7:0
0h	Reserved	
1h	Host MAC Address Byte 2	Host MAC Address Byte 1
2h	Host MAC Address Byte 4	Host MAC Address Byte 3
3h	Host MAC Address Byte 6	Host MAC Address Byte 5
4h - 6h	Reserved	
7h - 3Fh	Not used for the KSZ8441 (Available for user-defined purposes)	

# KSZ8441HL/FHL

---

NOTES:



## 4.0 REGISTER DESCRIPTIONS

The KSZ8441 has a rich set of registers available to manage the functionality of the device. Access to these registers is via the host interface (BIU). The device can be programmed to automatically load register locations 0x110 – 0x115 with a MAC address stored in Word locations 01h – 03h in an external serial EEPROM. [Figure 4-1](#) provides a global picture of accessibility via the various interfaces and addressing ranges from the perspective of each interface.

**FIGURE 4-1: INTERFACE AND REGISTER MAPPING**

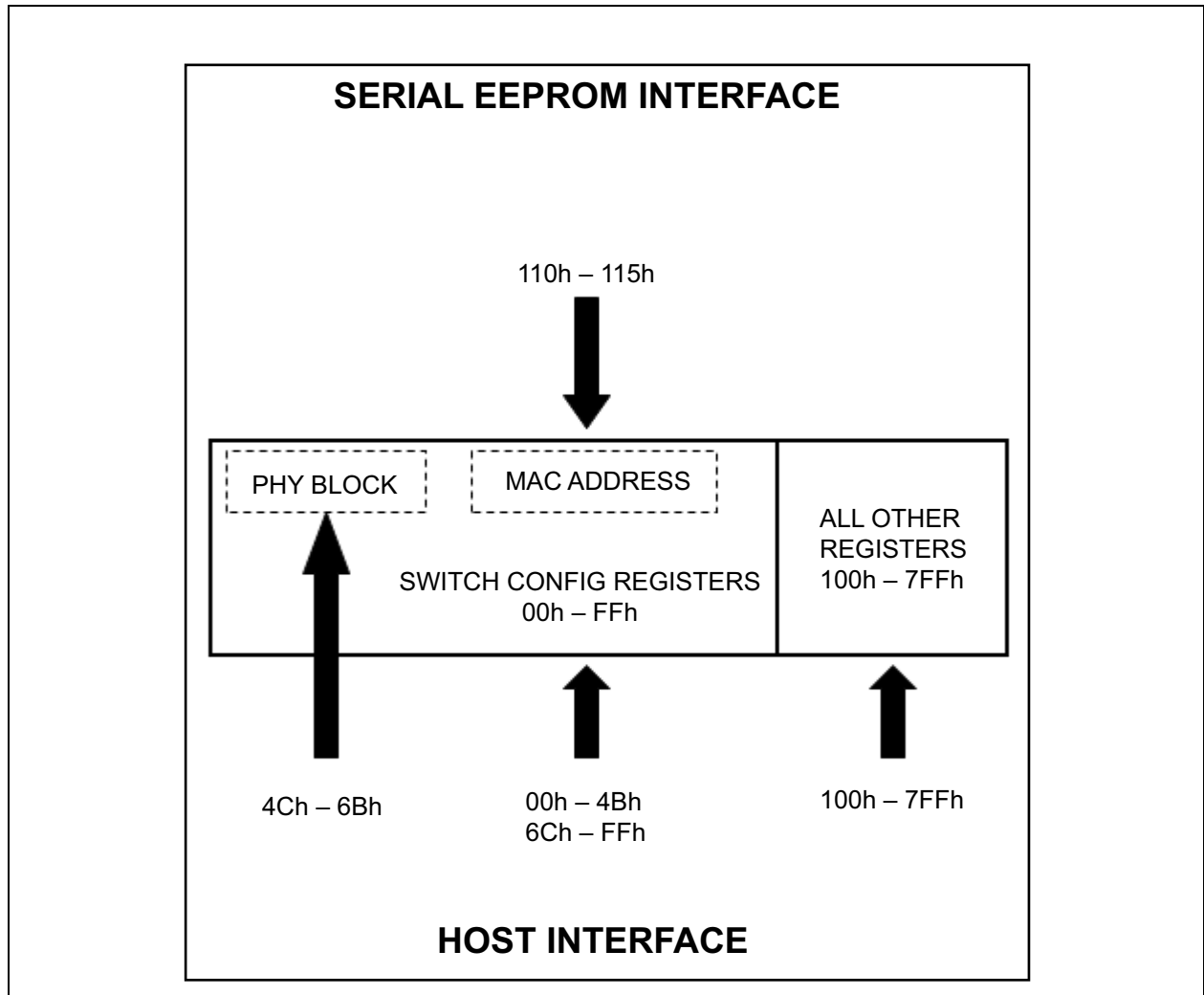

The registers within the linear 0x000 – 0x7FF address space are all accessible via the host interface bus by a microprocessor or CPU. The mapping of the various functions within that linear address space is summarized in [Table 4-1](#).

# KSZ8441HL/FHL

**TABLE 4-1: MAPPING OF FUNCTIONAL AREAS WITHIN THE ADDRESS SPACE**

Register Locations	Device Area	Description
0x000 – 0x0FF	Device Control and Configuration	Registers that control the overall functionality of the MAC, PHY, and other.
0x026 – 0x031	Indirect Access Registers	Registers used to indirectly address and access distinct areas within the device. <ul style="list-style-type: none"> <li>Management Information Base (MIB) Counters</li> </ul>
0x044 – 0x06B	PHY1 Registers	The same PHY registers as specified in IEEE 802.3 specification
0x100 – 0x16F	Interrupts, Global Reset, BIU	Registers and bits associated with interrupts, global reset, and the BIU
0x170 – 0x1FF	QMU	Registers and bits associated with the QMU
0x200 – 0x5FF	IEEE 1588 PTP Event Trigger Control and Output Registers	Registers used to configure and use the IEEE 1588 trigger functions
0x600 – 0x7FF	IEEE 1588 PTP Clock and Global Control	Registers that control the IEEE PTP Clock Control, Port Egress, Messaging, Port Ingress/Egress time stamp attributes

## 4.1 Register Map of CPU Accessible I/O Registers

The registers in the address range 00h through 7FFh can be read or written by a local CPU attached to the host interface. If enabled, registers 0x110 – 0x115 can be loaded at power on time by contents in the serial EEPROM. These registers are used for configuring the MAC address of the device.

### 4.1.1 I/O REGISTERS

The following I/O register space mapping table applies to 8-bit or 16-bit locations. Depending upon the mode selected, each I/O access can be performed using 8-bit or 16-bit wide transfers.

**TABLE 4-2: INTERNAL I/O REGISTER SPACE MAPPING FOR GENERAL CONTROL AND CONFIGURATION (0X000 – 0X0FF)**

I/O Register Offset Location		Register Name	Default Value	Description
16-Bit	8-Bit			
0x000 – 0x001	0x000 0x001	CIDER	0x8413	Chip ID and Enable Register [15:0]
0x002 – 0x003	0x002 0x003	GGCR1	0x3450	General Global Control Register 1 [15:0]
0x004 – 0x00D	0x004 0x00D	Reserved (10-Bytes)	Don't Care	None
0x00E – 0x00F	0x00E 0x00F	GGCR7	0x0827	General Global Control Register 7 [15:0]
0x010 – 0x011	0x010 0x011	MACAR1	0x0010	MAC Address Register 1 [15:0]
0x012 – 0x013	0x012 0x013	MACAR2	0xA1FF	MAC Address Register 2 [15:0]
0x014 – 0x015	0x014 0x015	MACAR3	0xFFFF	MAC Address Register 3 [15:0]
0x016 – 0x025	0x016 0x025	Reserved (16-Bytes)	Don't Care	None
0x026 – 0x027	0x026 0x027	IADR1	0x0000	Indirect Access Data Register 1 [15:0]

**TABLE 4-2: INTERNAL I/O REGISTER SPACE MAPPING FOR GENERAL CONTROL AND CONFIGURATION (0X000 – 0X0FF) (CONTINUED)**

I/O Register Offset Location		Register Name	Default Value	Description
16-Bit	8-Bit			
0x028 – 0x02B	0x028 0x02B	Reserved (4-Bytes)	Don't Care	None
0x02C – 0x02D	0x02C 0x02D	IADR4	0x0000	Indirect Access Data Register 4 [15:0]
0x02E – 0x02F	0x02E 0x02F	IADR5	0x0000	Indirect Access Data Register 5 [15:0]
0x030 – 0x031	0x030 0x031	IACR	0x0000	Indirect Access Control Register [15:0]
0x032 – 0x033	0x032 0x033	PMCTRL	0x0000	Power Management Control and Wake-up Event Status Register [15:0]
0x034 – 0x035	0x034 0x035	PMEE	0x0000	Power Management Event Enable Register [15:0]
0x036 – 0x037	0x036 0x037	GST	0x008E	Go Sleep Time Register [15:0]
0x038 – 0x039	0x038 0x039	CTPDC	0x0000	Clock Tree Power Down Control Register [15:0]
0x03A – 0x04B	0x03A 0x04B	Reserved (18-Bytes)	Don't Care	None
0x04C – 0x04D	0x04C 0x04D	P1MBCR	0x3120	PHY 1 and MII Basic Control Register [15:0]
0x04E – 0x04F	0x04E 0x04F	P1MBSR	0x7808	PHY 1 and MII Basic Status Register [15:0]
0x050 – 0x051	0x050 0x051	PHY1ILR	0x1430	PHY 1 PHYID Low Register [15:0]
0x052 – 0x053	0x052 0x053	PHY1IHR	0x0022	PHY 1 PHYID High Register [15:0]
0x054 – 0x055	0x054 0x055	P1ANAR	0x05E1	PHY 1 Auto-Negotiation Advertisement Register [15:0]
0x056 – 0x057	0x056 0x057	P1ANLPR	0x0001	PHY 1 Auto-Negotiation Link Partner Ability Register [15:0]
0x058 – 0x065	0x058 0x065	Reserved (14-Bytes)	Don't Care	None
0x066 – 0x067	0x066 0x067	P1PHYCTRL	0x0004	PHY 1 Special Control and Status Register [15:0]
0x068 – 0x06B	0x068 0x06B	Reserved (4-Bytes)	Don't Care	None
0x06C – 0x06D	0x06C 0x06D	P1CR1	0x0000	Port 1 Control Register 1 [15:0]
0x06E – 0x07B	0x06E 0x07B	Reserved (14-Bytes)	Don't Care	None
0x07C – 0x07D	0x07C 0x07D	P1SCSLMD	0x0400	Port 1 PHY Special Control/Status, LinkMD Register [15:0]
0x07E – 0x07F	0x07E 0x07F	P1CR4	0x00FF	Port 1 Control Register 4 [15:0]
0x080 – 0x081	0x080 0x081	P1SR	0x8000	Port 1 Status Register [15:0]

# KSZ8441HL/FHL

**TABLE 4-2: INTERNAL I/O REGISTER SPACE MAPPING FOR GENERAL CONTROL AND CONFIGURATION (0X000 – 0X0FF) (CONTINUED)**

I/O Register Offset Location		Register Name	Default Value	Description
16-Bit	8-Bit			
0x082 – 0x0D5	0x082 0x0D5	Reserved (84-Bytes)	Don't Care	None
0x0D6 – 0x0D7	0x0D6 0x0D7	IOMUXSEL	0x0FFF	Input and Output Multiplex Selection Register [15:0]
0x0D8 – 0x0D9	0x0D8 0x0D9	CFGR	0x00FE	Configuration Status and Serial Bus Mode Register [15:0]
0x0DA – 0x0DB	0x0DA 0x0DB	Reserved (2-Bytes)	Don't Care	None
0x0DC – 0x0DD	0x0DC 0x0DD	P1ANPT	0x2001	Port 1 Auto-Negotiation Next Page Transmit Register [15:0]
0x0DE – 0x0DF	0x0DE 0x0DF	P1ALPRNP	0x0000	Port 1 Auto-Negotiation Link Partner Received Next Page Register [15:0]
0x0E0 – 0x0E1	0x0E0 0x0E1	P1EEEA	0x0002	Port 1 EEE and Link Partner Advertisement Register [15:0]
0x0E2 – 0x0E3	0x0E2 0x0E3	P1EEEWEC	0x0000	Port 1 EEE Wake Error Count Register [15:0]
0x0E4 – 0x0E5	0x0E4 0x0E5	P1EEECS	0x8064	Port 1 EEE Control/Status and Auto-Negotiation Expansion Register [15:0]
0x0E6 – 0x0E7	0x0E6 0x0E7	P1LPIRTC BL2LPIC1	0x27 0x08	Port 1 LPI Recovery Time Counter Register [7:0] Buffer Load to LPI Control 1 Register [7:0]
0x0E8 – 0x0F1	0x0E8 0x0F1	Reserved (10-Bytes)	Don't Care	None
0x0F2 – 0x0F3	0x0F2 0x0F3	PCSEEEC	0x0327	PCS EEE Control Register [7:0]
0x0F4 – 0x0F5	0x0F4 0x0F5	ETLWTC	0x03E8	Empty TXQ to LPI Wait Time Control Register [15:0]
0x0F6 – 0x0F7	0x0F6 0x0F7	BL2LPIC2	0xC040	Buffer Load to LPI Control 2 Register [15:0]
0x0F8 – 0x0FF	0x0F8 0x0FF	Reserved (8-Bytes)	Don't Care	None

**TABLE 4-3: INTERNAL I/O REGISTER SPACE MAPPING FOR HOST INTERFACE UNIT (0X100 – 0X16F)**

I/O Register Offset Location		Register Name	Default Value	Description
16-Bit	8-Bit			
0x100 - 0x107	0x100 0x107	Reserved (8-Bytes)	Don't Care	None
0x108 - 0x109	0x108 0x109	CCR	Read Only	Chip Configuration Register [15:0]
0x10A - 0x10F	0x10A 0x10F	Reserved (6-Bytes)	Don't Care	None
0x110 - 0x111	0x110 0x111	MARL	—	MAC Address Register Low [15:0]
0x112 - 0x113	0x112 0x113	MARM	—	MAC Address Register Middle [15:0]

**TABLE 4-3: INTERNAL I/O REGISTER SPACE MAPPING FOR HOST INTERFACE UNIT (0X100 – 0X16F) (CONTINUED)**

I/O Register Offset Location		Register Name	Default Value	Description
16-Bit	8-Bit			
0x114 - 0x115	0x114 0x115	MARH	—	MAC Address Register High [15:0]
0x116 - 0x121	0x116 0x121	Reserved (12-Bytes)	Don't Care	None
0x122 - 0x123	0x122 0x123	EEPCR	0x0000	EEPROM Control Register [15:0]
0x124 - 0x125	0x124 0x125	MBIR	0x0000	Memory BIST Info Register [15:0]
0x126 - 0x127	0x126 0x127	GRR	0x0000	Global Reset Register [15:0]
0x128 - 0x129	0x128 0x129	Reserved (2-Bytes)	Don't Care	None
0x12A - 0x12B	0x12A 0x12B	WFCR	0x0000	Wake-Up Frame Control Register [15:0]
0x12C - 0x12F	0x12C 0x12F	Reserved (4-Bytes)	Don't Care	None
0x130 - 0x131	0x130 0x131	WF0CRC0	0x0000	Wake-Up Frame 0 CRC0 Register [15:0]
0x132 - 0x133	0x132 0x133	WF0CRC1	0x0000	Wake-Up Frame 0 CRC1 Register [15:0]
0x134 - 0x135	0x134 0x135	WF0BM0	0x0000	Wake-Up Frame 0 Byte Mask 0 Register [15:0]
0x136 - 0x137	0x136 0x137	WF0BM1	0x0000	Wake-Up Frame 0 Byte Mask 1 Register [15:0]
0x138 - 0x139	0x138 0x139	WF0BM2	0x0000	Wake-Up Frame 0 Byte Mask 2 Register [15:0]
0x13A - 0x13B	0x13A 0x13B	WF0BM3	0x0000	Wake-Up Frame 0 Byte Mask 3 Register [15:0]
0x13C - 0x13F	0x13C 0x13F	Reserved (4-Bytes)	Don't Care	None
0x140 - 0x141	0x140 0x141	WF1CRC0	0x0000	Wake-Up Frame 1 CRC0 Register [15:0]
0x142 - 0x143	0x142 0x143	WF1CRC1	0x0000	Wake-Up Frame 1 CRC1 Register [15:0]
0x144 - 0x145	0x144 0x145	WF1BM0	0x0000	Wake-Up Frame 1 Byte Mask 0 Register [15:0]
0x146 - 0x147	0x146 0x147	WF1BM1	0x0000	Wake-Up Frame 1 Byte Mask 1 Register [15:0]
0x148 - 0x149	0x148 0x149	WF1BM2	0x0000	Wake-Up Frame 1 Byte Mask 2 Register [15:0]
0x14A - 0x14B	0x14A 0x14B	WF1BM3	0x0000	Wake-Up Frame 1 Byte Mask 3 Register [15:0]
0x14C - 0x14F	0x14C 0x14F	Reserved (4-Bytes)	Don't Care	None
0x150 - 0x151	0x150 0x151	WF2CRC0	0x0000	Wake-Up Frame 2 CRC0 Register [15:0]

# KSZ8441HL/FHL

**TABLE 4-3: INTERNAL I/O REGISTER SPACE MAPPING FOR HOST INTERFACE UNIT (0X100 – 0X16F) (CONTINUED)**

I/O Register Offset Location		Register Name	Default Value	Description
16-Bit	8-Bit			
0x152 - 0x153	0x152 0x153	WF2CRC1	0x0000	Wake-Up Frame 2 CRC1 Register [15:0]
0x154 - 0x155	0x154 0x155	WF2BM0	0x0000	Wake-Up Frame 2 Byte Mask 0 Register [15:0]
0x156 - 0x157	0x156 0x157	WF2BM1	0x0000	Wake-Up Frame 2 Byte Mask 1 Register [15:0]
0x158 - 0x159	0x158 0x159	WF2BM2	0x0000	Wake-Up Frame 2 Byte Mask 2 Register [15:0]
0x15A - 0x15B	0x15A 0x15B	WF2BM3	0x0000	Wake-Up Frame 2 Byte Mask 3 Register [15:0]
0x15C - 0x15F	0x15C 0x15F	Reserved (4-Bytes)	Don't Care	None
0x160 - 0x161	0x160 0x161	WF3CRC0	0x0000	Wake-Up Frame 3 CRC0 Register [15:0]
0x162 - 0x163	0x162 0x163	WF3CRC1	0x0000	Wake-Up Frame 3 CRC1 Register [15:0]
0x164 - 0x165	0x164 0x165	WF3BM0	0x0000	Wake-Up Frame 3 Byte Mask 0 Register [15:0]
0x166 - 0x167	0x166 0x167	WF3BM1	0x0000	Wake-Up Frame 3 Byte Mask 1 Register [15:0]
0x168 - 0x169	0x168 0x169	WF3BM2	0x0000	Wake-Up Frame 3 Byte Mask 2 Register [15:0]
0x16A - 0x16B	0x16A 0x16B	WF3BM3	0x0000	Wake-Up Frame 3 Byte Mask 3 Register [15:0]
0x16C - 0x16F	0x16C 0x16F	Reserved (4-Bytes)	Don't Care	None

**TABLE 4-4: INTERNAL I/O REGISTER SPACE MAPPING FOR THE QMU (0X170 – 0X1FF)**

I/O Register Offset Location		Register Name	Default Value	Description
16-Bit	8-Bit			
0x170 - 0x171	0x170 0x171	TXCR	0x0000	Transmit Control Register [15:0]
0x172 - 0x173	0x172 0x173	TXSR	0x0000	Transmit Status Register [15:0]
0x174 - 0x175	0x174 0x175	RXCR1	0x0800	Receive Control Register 1 [15:0]
0x176 - 0x177	0x176 0x177	RXCR2	0x0114	Receive Control Register 2 [15:0]
0x178 - 0x179	0x178 0x179	TXMIR	0x1800	TXQ Memory Information Register [15:0]
0x17A - 0x17B	0x17A 0x17B	Reserved (2-Bytes)	Don't Care	None
0x17C - 0x17D	0x17C 0x17D	RXFHSR	0x0000	Receive Frame Header Status Register [15:0]
0x17E - 0x17F	0x17E 0x17F	RXFHBCR	0x0000	Receive Frame Header Byte Count Register [15:0]

**TABLE 4-4: INTERNAL I/O REGISTER SPACE MAPPING FOR THE QMU (0X170 – 0X1FF)  
(CONTINUED)**

I/O Register Offset Location		Register Name	Default Value	Description
16-Bit	8-Bit			
0x180 - 0x181	0x180 0x181	TXQCR	0x0000	TXQ Command Register [15:0]
0x182 - 0x183	0x182 0x183	RXQCR	0x0000	RXQ Command Register [15:0]
0x184 - 0x185	0x184 0x185	TXFDPR	0x0000	TX Frame Data Pointer Register [15:0]
0x186 - 0x187	0x186 0x187	RXFDPR	0x1000	RX Frame Data Pointer Register [15:0]
0x188 - 0x18B	0x188 0x18B	Reserved (4-Bytes)	Don't Care	None
0x18C - 0x18D	0x18C 0x18D	RXDTR	0x0000	RX Duration Timer Threshold Register [15:0]
0x18E - 0x18F	0x18E 0x18F	RXDBCTR	0x0000	RX Data Byte Count Threshold Register [15:0]
0x190 - 0x191	0x190 0x191	IER	0x0000	Interrupt Enable Register [15:0]
0x192 - 0x193	0x192 0x193	ISR	0x0000	Interrupt Status Register [15:0]
0x194 - 0x19B	0x194 0x19B	Reserved (8-Bytes)	Don't Care	None
0x19C - 0x19D	0x19C 0x19D	RXFCTR	0x0000	RX Frame Count Threshold Register [7:0], [15:8] are Reserved
0x19E - 0x19F	0x19E 0x19F	TXNTFSR	0x0000	TX Next Total Frames Size Register [15:0]
0x1A0 - 0x1A1	0x1A0 0x1A1	MAHTR0	0x0000	MAC Address Hash Table Register 0 [15:0]
0x1A2 - 0x1A3	0x1A2 0x1A3	MAHTR1	0x0000	MAC Address Hash Table Register 1 [15:0]
0x1A4 - 0x1A5	0x1A4 0x1A5	MAHTR2	0x0000	MAC Address Hash Table Register 2 [15:0]
0x1A6 - 0x1A7	0x1A6 0x1A7	MAHTR3	0x0000	MAC Address Hash Table Register 3 [15:0]
0x1A8 - 0x1AF	0x1A8 0x1AF	Reserved (8-Bytes)	Don't Care	None
0x1B0 - 0x1B1	0x1B0 0x1B1	FCLWR	0x0600	Flow Control Low Water Mark Register [15:0]
0x1B2 - 0x1B3	0x1B2 0x1B3	FCHWR	0x0400	Flow Control High Water Mark Register [15:0]
0x1B4 - 0x1B5	0x1B4 0x1B5	FCOWR	0x0040	Flow Control Overrun Water Mark Register [15:0]
0x1B6 - 0x1B7	0x1B6 0x1B7	Reserved (2-Bytes)	Don't Care	None
0x1B8 - 0x1B9	0x1B8 0x1B9	RXFC	0x00	RX Frame Count[15:8], Reserved [7:0]
0x1BA - 0x1FF	0x1BA 0x1FF	Reserved (70-Bytes)	Don't Care	None

# KSZ8441HL/FHL

**TABLE 4-5: INTERNAL I/O REGISTER SPACE MAPPING FOR PTP TRIGGER OUTPUT (12 UNITS, 0X200 – 0X3FF)**

I/O Register Offset Location		Register Name	Default Value	Description
16-Bit	8-Bit			
0x200 – 0x201	0x200 0x201	TRIG_ERR	0x0000	Trigger Output Unit Error Register [11:0]
0x202 – 0x203	0x202 0x203	TRIG_ACTIVE	0x0000	Trigger Output Unit Active Register [11:0]
0x204 – 0x205	0x204 0x205	TRIG_DONE	0x0000	Trigger Output Unit Done Register [11:0]
0x206 – 0x207	0x206 0x207	TRIG_EN	0x0000	Trigger Output Unit Enable Register [11:0]
0x208 – 0x209	0x208 0x209	TRIG_SW_RST	0x0000	Trigger Output Unit Software Reset Register [11:0]
0x20A – 0x20B	0x20A 0x20B	TRIG12_PPS_WIDTH	0x0000	Trigger Output Unit 12 PPS Pulse Width Register
0x20C – 0x21F	0x20C 0x21F	Reserved (20-Bytes)	Don't Care	None
0x220 – 0x221	0x220 0x221	TRIG1_TGT_NSL	0x0000	Trigger Output Unit 1 Target Time in Nanoseconds Low-Word Register [15:0]
0x222 – 0x223	0x222 0x223	TRIG1_TGT_NSH	0x0000	Trigger Output Unit 1 Target Time in Nanoseconds High-Word Register [29:16]
0x224 – 0x225	0x224 0x225	TRIG1_TGT_SL	0x0000	Trigger Output Unit 1 Target Time in Seconds Low-Word Register [15:0]
0x226 – 0x227	0x226 0x227	TRIG1_TGT_SH	0x0000	Trigger Output Unit 1 Target Time in Seconds High-Word Register [31:16]
0x228 – 0x229	0x228 0x229	TRIG1_CFG_1	0x3C00	Trigger Output Unit 1 Configuration/Control Register1
0x22A – 0x22B	0x22A 0x22B	TRIG1_CFG_2	0x0000	Trigger Output Unit 1 Configuration/Control Register2
0x22C – 0x22D	0x22C 0x22D	TRIG1_CFG_3	0x0000	Trigger Output Unit 1 Configuration/Control Register3
0x22E – 0x22F	0x22E 0x22F	TRIG1_CFG_4	0x0000	Trigger Output Unit 1 Configuration/Control Register4
0x230 – 0x231	0x230 0x231	TRIG1_CFG_5	0x0000	Trigger Output Unit 1 Configuration/Control Register5
0x232 – 0x233	0x232 0x233	TRIG1_CFG_6	0x0000	Trigger Output Unit 1 Configuration/Control Register6
0x234 – 0x235	0x234 0x235	TRIG1_CFG_7	0x0000	Trigger Output Unit 1 Configuration/Control Register7
0x236 – 0x237	0x236 0x237	TRIG1_CFG_8	0x0000	Trigger Output Unit 1 Configuration/Control Register8
0x238 – 0x23F	0x238 0x23F	Reserved (8-Bytes)	Don't Care	None
0x240 – 0x241	0x240 0x241	TRIG2_TGT_NSL	0x0000	Trigger Output Unit 2 Target Time in Nanoseconds Low-Word Register [15:0]
0x242 – 0x243	0x242 0x243	TRIG2_TGT_NSH	0x0000	Trigger Output Unit 2 Target Time in Nanoseconds High-Word Register [29:16]
0x244 – 0x245	0x244 0x245	TRIG2_TGT_SL	0x0000	Trigger Output Unit 2 Target Time in Seconds Low-Word Register [15:0]



**TABLE 4-5: INTERNAL I/O REGISTER SPACE MAPPING FOR PTP TRIGGER OUTPUT (12 UNITS, 0X200 – 0X3FF) (CONTINUED)**

I/O Register Offset Location		Register Name	Default Value	Description
16-Bit	8-Bit			
0x246 – 0x247	0x246 0x247	TRIG2_T- GT_SH	0x0000	Trigger Output Unit 2 Target Time in Seconds High-Word Register [31:16]
0x248 – 0x249	0x248 0x249	TRIG2_CFG_1	0x3C00	Trigger Output Unit 2 Configuration/Control Register1
0x24A – 0x24B	0x24A 0x24B	TRIG2_CFG_2	0x0000	Trigger Output Unit 2 Configuration/Control Register2
0x24C – 0x24D	0x24C 0x24D	TRIG2_CFG_3	0x0000	Trigger Output Unit 2 Configuration/Control Register3
0x24E – 0x24F	0x24E 0x24F	TRIG2_CFG_4	0x0000	Trigger Output Unit 2 Configuration/Control Register4
0x250 – 0x251	0x250 0x251	TRIG2_CFG_5	0x0000	Trigger Output Unit 2 Configuration/Control Register5
0x252 – 0x253	0x252 0x253	TRIG2_CFG_6	0x0000	Trigger Output Unit 2 Configuration/Control Register6
0x254 – 0x255	0x254 0x255	TRIG2_CFG_7	0x0000	Trigger Output Unit 2 Configuration/Control Register7
0x256 – 0x257	0x256 0x257	TRIG2_CFG_8	0x0000	Trigger Output Unit 2 Configuration/Control Register8
0x258 – 0x25F	0x258 0x25F	Reserved (8-Bytes)	Don't Care	None
0x260 – 0x261	0x260 0x261	TRIG3_T- GT_NSL	0x0000	Trigger Output Unit 3 Target Time in Nanoseconds Low-Word Register [15:0]
0x262 – 0x263	0x262 0x263	TRIG3_T- GT_NSH	0x0000	Trigger Output Unit 3 Target Time in Nanoseconds High-Word Register [29:16]
0x264 – 0x265	0x264 0x265	TRIG3_TGT_SL	0x0000	Trigger Output Unit 3 Target Time in Seconds Low-Word Register [15:0]
0x266 – 0x267	0x266 0x267	TRIG3_T- GT_SH	0x0000	Trigger Output Unit 3 Target Time in Seconds High-Word Register [31:16]
0x268 – 0x269	0x268 0x269	TRIG3_CFG_1	0x3C00	Trigger Output Unit 3 Configuration/Control Register1
0x26A – 0x26B	0x26A 0x26B	TRIG3_CFG_2	0x0000	Trigger Output Unit 3 Configuration/Control Register2
0x26C – 0x26D	0x26C 0x26D	TRIG3_CFG_3	0x0000	Trigger Output Unit 3 Configuration/Control Register3
0x26E – 0x26F	0x26E 0x26F	TRIG3_CFG_4	0x0000	Trigger Output Unit 3 Configuration/Control Register4
0x270 – 0x271	0x270 0x271	TRIG3_CFG_5	0x0000	Trigger Output Unit 3 Configuration/Control Register5
0x272 – 0x273	0x272 0x273	TRIG3_CFG_6	0x0000	Trigger Output Unit 3 Configuration/Control Register6
0x274 – 0x275	0x274 0x275	TRIG3_CFG_7	0x0000	Trigger Output Unit 3 Configuration/Control Register7
0x276 – 0x277	0x276 0x277	TRIG3_CFG_8	0x0000	Trigger Output Unit 3 Configuration/Control Register8
0x278 – 0x27F	0x278 0x27F	Reserved (8-Bytes)	Don't Care	None

# KSZ8441HL/FHL

**TABLE 4-5: INTERNAL I/O REGISTER SPACE MAPPING FOR PTP TRIGGER OUTPUT (12 UNITS, 0X200 – 0X3FF) (CONTINUED)**

I/O Register Offset Location		Register Name	Default Value	Description
16-Bit	8-Bit			
0x280 – 0x281	0x280 0x281	TRIG4_T- GT_NSL	0x0000	Trigger Output Unit 4 Target Time in Nano-seconds Low-Word Register [15:0]
0x282 – 0x283	0x282 0x283	TRIG4_T- GT_NSH	0x0000	Trigger Output Unit 4 Target Time in Nano-seconds High-Word Register [29:16]
0x284 – 0x285	0x284 0x285	TRIG4_TGT_SL	0x0000	Trigger Output Unit 4 Target Time in Seconds Low-Word Register [15:0]
0x286 – 0x287	0x286 0x287	TRIG4_T- GT_SH	0x0000	Trigger Output Unit 4 Target Time in Seconds High-Word Register [31:16]
0x288 – 0x289	0x288 0x289	TRIG4_CFG_1	0x3C00	Trigger Output Unit 4 Configuration/Control Register1
0x28A – 0x28B	0x28A 0x28B	TRIG4_CFG_2	0x0000	Trigger Output Unit 4 Configuration/Control Register2
0x28C – 0x28D	0x28C 0x28D	TRIG4_CFG_3	0x0000	Trigger Output Unit 4 Configuration/Control Register3
0x28E – 0x28F	0x28E 0x28F	TRIG4_CFG_4	0x0000	Trigger Output Unit 4 Configuration/Control Register4
0x290 – 0x291	0x290 0x291	TRIG4_CFG_5	0x0000	Trigger Output Unit 4 Configuration/Control Register5
0x292 – 0x293	0x292 0x293	TRIG4_CFG_6	0x0000	Trigger Output Unit 4 Configuration/Control Register6
0x294 – 0x295	0x294 0x295	TRIG4_CFG_7	0x0000	Trigger Output Unit 4 Configuration/Control Register7
0x296 – 0x297	0x296 0x297	TRIG4_CFG_8	0x0000	Trigger Output Unit 4 Configuration/Control Register8
0x298 – 0x29F	0x298 0x29F	Reserved (8-Bytes)	Don't Care	None
0x2A0 – 0x2A1	0x2A0 0x2A1	TRIG5_T- GT_NSL	0x0000	Trigger Output Unit 5 Target Time in Nano-seconds Low-Word Register [15:0]
0x2A2 – 0x2A3	0x2A2 0x2A3	TRIG5_T- GT_NSH	0x0000	Trigger Output Unit 5 Target Time in Nano-seconds High-Word Register [29:16]
0x2A4 – 0x2A5	0x2A4 0x2A5	TRIG5_TGT_SL	0x0000	Trigger Output Unit 5 Target Time in Seconds Low-Word Register [15:0]
0x2A6 – 0x2A7	0x2A6 0x2A7	TRIG5_T- GT_SH	0x0000	Trigger Output Unit 5 Target Time in Seconds High-Word Register [31:16]
0x2A8 – 0x2A9	0x2A8 0x2A9	TRIG5_CFG_1	0x3C00	Trigger Output Unit 5 Configuration/Control Register1
0x2AA – 0x2AB	0x2AA 0x2AB	TRIG5_CFG_2	0x0000	Trigger Output Unit 5 Configuration/Control Register2
0x2AC – 0x2AD	0x2AC 0x2AD	TRIG5_CFG_3	0x0000	Trigger Output Unit 5 Configuration/Control Register3
0x2AE – 0x2AF	0x2AE 0x2AF	TRIG5_CFG_4	0x0000	Trigger Output Unit 5 Configuration/Control Register4
0x2B0 – 0x2B1	0x2B0 0x2B1	TRIG5_CFG_5	0x0000	Trigger Output Unit 5 Configuration/Control Register5
0x2B2 – 0x2B3	0x2B2 0x2B3	TRIG5_CFG_6	0x0000	Trigger Output Unit 5 Configuration/Control Register6

**TABLE 4-5: INTERNAL I/O REGISTER SPACE MAPPING FOR PTP TRIGGER OUTPUT (12 UNITS, 0X200 – 0X3FF) (CONTINUED)**

I/O Register Offset Location		Register Name	Default Value	Description
16-Bit	8-Bit			
0x2B4 – 0x2B5	0x2B4 0x2B5	TRIG5_CFG_7	0x0000	Trigger Output Unit 5 Configuration/Control Register7
0x2B6 – 0x2B7	0x2B6 0x2B7	TRIG5_CFG_8	0x0000	Trigger Output Unit 5 Configuration/Control Register8
0x2B8 – 0x2BF	0x2B8 0x2BF	Reserved (8-Bytes)	Don't Care	None
0x2C0 – 0x2C1	0x2C0 0x2C1	TRIG6_T- GT_NSL	0x0000	Trigger Output Unit 6 Target Time in Nano-seconds Low-Word Register [15:0]
0x2C2 – 0x2C3	0x2C2 0x2C3	TRIG6_T- GT_NSH	0x0000	Trigger Output Unit 6 Target Time in Nano-seconds High-Word Register [29:16]
0x2C4 – 0x2C5	0x2C4 0x2C5	TRIG6_TGT_SL	0x0000	Trigger Output Unit 6 Target Time in Seconds Low-Word Register [15:0]
0x2C6 – 0x2C7	0x2C6 0x2C7	TRIG6_T- GT_SH	0x0000	Trigger Output Unit 6 Target Time in Seconds High-Word Register [31:16]
0x2C8 – 0x2C9	0x2C8 0x2C9	TRIG6_CFG_1	0x3C00	Trigger Output Unit 6 Configuration/Control Register1
0x2CA – 0x2CB	0x2CA 0x2CB	TRIG6_CFG_2	0x0000	Trigger Output Unit 6 Configuration/Control Register2
0x2CC – 0x2CD	0x2CC 0x2CD	TRIG6_CFG_3	0x0000	Trigger Output Unit 6 Configuration/Control Register3
0x2CE – 0x2CF	0x2CE 0x2CF	TRIG6_CFG_4	0x0000	Trigger Output Unit 6 Configuration/Control Register4
0x2D0 – 0x2D1	0x2D0 0x2D1	TRIG6_CFG_5	0x0000	Trigger Output Unit 6 Configuration/Control Register5
0x2D2 – 0x2D3	0x2D2 0x2D3	TRIG6_CFG_6	0x0000	Trigger Output Unit 6 Configuration/Control Register6
0x2D4 – 0x2D5	0x2D4 0x2D5	TRIG6_CFG_7	0x0000	Trigger Output Unit 6 Configuration/Control Register7
0x2D6 – 0x2D7	0x2D6 0x2D7	TRIG6_CFG_8	0x0000	Trigger Output Unit 6 Configuration/Control Register8
0x2D8 – 0x2DF	0x2D8 0x2DF	Reserved (8-Bytes)	Don't Care	None
0x2E0 – 0x2E1	0x2E0 0x2E1	TRIG7_T- GT_NSL	0x0000	Trigger Output Unit 7 Target Time in Nano-seconds Low-Word Register [15:0]
0x2E2 – 0x2E3	0x2E2 0x2E3	TRIG7_T- GT_NSH	0x0000	Trigger Output Unit 7 Target Time in Nano-seconds High-Word Register [29:16]
0x2E4 – 0x2E5	0x2E4 0x2E5	TRIG7_TGT_SL	0x0000	Trigger Output Unit 7 Target Time in Seconds Low-Word Register [15:0]
0x2E6 – 0x2E7	0x2E6 0x2E7	TRIG7_T- GT_SH	0x0000	Trigger Output Unit 7 Target Time in Seconds High-Word Register [31:16]
0x2E8 – 0x2E9	0x2E8 0x2E9	TRIG7_CFG_1	0x3C00	Trigger Output Unit 7 Configuration/Control Register1
0x2EA – 0x2EB	0x2EA 0x2EB	TRIG7_CFG_2	0x0000	Trigger Output Unit 7 Configuration/Control Register2
0x2EC – 0x2ED	0x2EC 0x2ED	TRIG7_CFG_3	0x0000	Trigger Output Unit 7 Configuration/Control Register3

# KSZ8441HL/FHL

**TABLE 4-5: INTERNAL I/O REGISTER SPACE MAPPING FOR PTP TRIGGER OUTPUT (12 UNITS, 0X200 – 0X3FF) (CONTINUED)**

I/O Register Offset Location		Register Name	Default Value	Description
16-Bit	8-Bit			
0x2EE – 0x2EF	0x2EE 0x2EF	TRIG7_CFG_4	0x0000	Trigger Output Unit 7 Configuration/Control Register4
0x2F0 – 0x2F1	0x2F0 0x2F1	TRIG7_CFG_5	0x0000	Trigger Output Unit 7 Configuration/Control Register5
0x2F2 – 0x2F3	0x2F2 0x2F3	TRIG7_CFG_6	0x0000	Trigger Output Unit 7 Configuration/Control Register6
0x2F4 – 0x2F5	0x2F4 0x2F5	TRIG7_CFG_7	0x0000	Trigger Output Unit 7 Configuration/Control Register7
0x2F6 – 0x2F7	0x2F6 0x2F7	TRIG7_CFG_8	0x0000	Trigger Output Unit 7 Configuration/Control Register8
0x2F8 – 0x2FF	0x2F8 0x2FF	Reserved (8-Bytes)	Don't Care	None
0x300 – 0x301	0x300 0x301	TRIG8_T- GT_NSL	0x0000	Trigger Output Unit 8 Target Time in Nano-seconds Low-Word Register [15:0]
0x302 – 0x303	0x302 0x303	TRIG8_T- GT_NSH	0x0000	Trigger Output Unit 8 Target Time in Nano-seconds High-Word Register [29:16]
0x304 – 0x305	0x304 0x305	TRIG8_TGT_SL	0x0000	Trigger Output Unit 8 Target Time in Seconds Low-Word Register [15:0]
0x306 – 0x307	0x306 0x307	TRIG8_T- GT_SH	0x0000	Trigger Output Unit 8 Target Time in Seconds High-Word Register [31:16]
0x308 – 0x309	0x308 0x309	TRIG8_CFG_1	0x3C00	Trigger Output Unit 8 Configuration/Control Register1
0x30A – 0x30B	0x30A 0x30B	TRIG8_CFG_2	0x0000	Trigger Output Unit 8 Configuration/Control Register2
0x30C – 0x30D	0x30C 0x30D	TRIG8_CFG_3	0x0000	Trigger Output Unit 8 Configuration/Control Register3
0x30E – 0x30F	0x30E 0x30F	TRIG8_CFG_4	0x0000	Trigger Output Unit 8 Configuration/Control Register4
0x310 – 0x311	0x310 0x311	TRIG8_CFG_5	0x0000	Trigger Output Unit 8 Configuration/Control Register5
0x312 – 0x313	0x312 0x313	TRIG8_CFG_6	0x0000	Trigger Output Unit 8 Configuration/Control Register6
0x314 – 0x315	0x314 0x315	TRIG8_CFG_7	0x0000	Trigger Output Unit 8 Configuration/Control Register7
0x316 – 0x317	0x316 0x317	TRIG8_CFG_8	0x0000	Trigger Output Unit 8 Configuration/Control Register8
0x318 – 0x31F	0x318 0x31F	Reserved (8-Bytes)	Don't Care	None
0x320 – 0x321	0x320 0x321	TRIG9_T- GT_NSL	0x0000	Trigger Output Unit 9 Target Time in Nano-seconds Low-Word Register [15:0]
0x322 – 0x323	0x322 0x323	TRIG9_T- GT_NSH	0x0000	Trigger Output Unit 9 Target Time in Nano-seconds High-Word Register [29:16]
0x324 – 0x325	0x324 0x325	TRIG9_TGT_SL	0x0000	Trigger Output Unit 9 Target Time in Seconds Low-Word Register [15:0]
0x326 – 0x327	0x326 0x327	TRIG9_T- GT_SH	0x0000	Trigger Output Unit 9 Target Time in Seconds High-Word Register [31:16]

**TABLE 4-5: INTERNAL I/O REGISTER SPACE MAPPING FOR PTP TRIGGER OUTPUT (12 UNITS, 0X200 – 0X3FF) (CONTINUED)**

I/O Register Offset Location		Register Name	Default Value	Description
16-Bit	8-Bit			
0x328 – 0x329	0x328 0x329	TRIG9_CFG_1	0x3C00	Trigger Output Unit 9 Configuration/Control Register1
0x32A – 0x32B	0x32A 0x32B	TRIG9_CFG_2	0x0000	Trigger Output Unit 9 Configuration/Control Register2
0x32C – 0x32D	0x32C 0x32D	TRIG9_CFG_3	0x0000	Trigger Output Unit 9 Configuration/Control Register3
0x32E – 0x32F	0x32E 0x32F	TRIG9_CFG_4	0x0000	Trigger Output Unit 9 Configuration/Control Register4
0x330 – 0x331	0x330 0x331	TRIG9_CFG_5	0x0000	Trigger Output Unit 9 Configuration/Control Register5
0x332 – 0x333	0x332 0x333	TRIG9_CFG_6	0x0000	Trigger Output Unit 9 Configuration/Control Register6
0x334 – 0x335	0x334 0x335	TRIG9_CFG_7	0x0000	Trigger Output Unit 9 Configuration/Control Register7
0x336 – 0x337	0x336 0x337	TRIG9_CFG_8	0x0000	Trigger Output Unit 9 Configuration/Control Register8
0x338 – 0x33F	0x338 0x33F	Reserved (8-Bytes)	Don't Care	None
0x340 – 0x341	0x340 0x341	TRIG10_T- GT_NSL	0x0000	Trigger Output Unit 10 Target Time in Nano-seconds Low-Word Register [15:0]
0x342 – 0x343	0x342 0x343	TRIG10_T- GT_NSH	0x0000	Trigger Output Unit 10 Target Time in Nano-seconds High-Word Register [29:16]
0x344 – 0x345	0x344 0x345	TRIG10_T- GT_SL	0x0000	Trigger Output Unit 10 Target Time in Seconds Low-Word Register [15:0]
0x346 – 0x347	0x346 0x347	TRIG10_T- GT_SH	0x0000	Trigger Output Unit 10 Target Time in Seconds High-Word Register [31:16]
0x348 – 0x349	0x348 0x349	TRIG10_CFG_1	0x3C00	Trigger Output Unit 10 Configuration/Control Register1
0x34A – 0x34B	0x34A 0x34B	TRIG10_CFG_2	0x0000	Trigger Output Unit 10 Configuration/Control Register2
0x34C – 0x34D	0x34C 0x34D	TRIG10_CFG_3	0x0000	Trigger Output Unit 10 Configuration/Control Register3
0x34E – 0x34F	0x34E 0x34F	TRIG10_CFG_4	0x0000	Trigger Output Unit 10 Configuration/Control Register4
0x350 – 0x351	0x350 0x351	TRIG10_CFG_5	0x0000	Trigger Output Unit 10 Configuration/Control Register5
0x352 – 0x353	0x352 0x353	TRIG10_CFG_6	0x0000	Trigger Output Unit 10 Configuration/Control Register6
0x354 – 0x355	0x354 0x355	TRIG10_CFG_7	0x0000	Trigger Output Unit 10 Configuration/Control Register7
0x356 – 0x357	0x356 0x357	TRIG10_CFG_8	0x0000	Trigger Output Unit 10 Configuration/Control Register8
0x358 – 0x35F	0x358 0x35F	Reserved (8-Bytes)	Don't Care	None
0x360 – 0x361	0x360 0x361	TRIG11_T- GT_NSL	0x0000	Trigger Output Unit 11 Target Time in Nano-seconds Low-Word Register [15:0]

# KSZ8441HL/FHL

**TABLE 4-5: INTERNAL I/O REGISTER SPACE MAPPING FOR PTP TRIGGER OUTPUT (12 UNITS, 0X200 – 0X3FF) (CONTINUED)**

I/O Register Offset Location		Register Name	Default Value	Description
16-Bit	8-Bit			
0x362 – 0x363	0x362 0x363	TRIG11_T- GT_NSH	0x0000	Trigger Output Unit 11 Target Time in Nano-seconds High-Word Register [29:16]
0x364 – 0x365	0x364 0x365	TRIG11_T- GT_SL	0x0000	Trigger Output Unit 11 Target Time in Seconds Low-Word Register [15:0]
0x366 – 0x367	0x366 0x367	TRIG11_T- GT_SH	0x0000	Trigger Output Unit 11 Target Time in Seconds High-Word Register [31:16]
0x368 – 0x369	0x368 0x369	TRIG11_CFG_1	0x3C00	Trigger Output Unit 11 Configuration/Control Register1
0x36A – 0x36B	0x36A 0x36B	TRIG11_CFG_2	0x0000	Trigger Output Unit 11 Configuration/Control Register2
0x36C – 0x36D	0x36C 0x36D	TRIG11_CFG_3	0x0000	Trigger Output Unit 11 Configuration/Control Register3
0x36E – 0x36F	0x36E 0x36F	TRIG11_CFG_4	0x0000	Trigger Output Unit 11 Configuration/Control Register4
0x370 – 0x371	0x370 0x371	TRIG11_CFG_5	0x0000	Trigger Output Unit 11 Configuration/Control Register5
0x372 – 0x373	0x372 0x373	TRIG11_CFG_6	0x0000	Trigger Output Unit 11 Configuration/Control Register6
0x374 – 0x375	0x374 0x375	TRIG11_CFG_7	0x0000	Trigger Output Unit 11 Configuration/Control Register7
0x376 – 0x377	0x376 0x377	TRIG11_CFG_8	0x0000	Trigger Output Unit 11 Configuration/Control Register8
0x378 – 0x37F	0x378 0x37F	Reserved (8-Bytes)	Don't Care	None
0x380 – 0x381	0x380 0x381	TRIG12_T- GT_NSL	0x0000	Trigger Output Unit 12 Target Time in Nano-seconds Low-Word Register [15:0]
0x382 – 0x383	0x382 0x383	TRIG12_T- GT_NSH	0x0000	Trigger Output Unit 12 Target Time in Nano-seconds High-Word Register [29:16]
0x384 – 0x385	0x384 0x385	TRIG12_T- GT_SL	0x0000	Trigger Output Unit 12 Target Time in Seconds Low-Word Register [15:0]
0x386 – 0x387	0x386 0x387	TRIG12_T- GT_SH	0x0000	Trigger Output Unit 12 Target Time in Seconds High-Word Register [31:16]
0x388 – 0x389	0x388 0x389	TRIG12_CFG_1	0x3C00	Trigger Output Unit 12 Configuration/Control Register1
0x38A – 0x38B	0x38A 0x38B	TRIG12_CFG_2	0x0000	Trigger Output Unit 12 Configuration/Control Register2
0x38C – 0x38D	0x38C 0x38D	TRIG12_CFG_3	0x0000	Trigger Output Unit 12 Configuration/Control Register3
0x38E – 0x38F	0x38E 0x38F	TRIG12_CFG_4	0x0000	Trigger Output Unit 12 Configuration/Control Register4
0x390 – 0x391	0x390 0x391	TRIG12_CFG_5	0x0000	Trigger Output Unit 12 Configuration/Control Register5
0x392 – 0x393	0x392 0x393	TRIG12_CFG_6	0x0000	Trigger Output Unit 12 Configuration/Control Register6
0x394 – 0x395	0x394 0x395	TRIG12_CFG_7	0x0000	Trigger Output Unit 12 Configuration/Control Register7

**TABLE 4-5: INTERNAL I/O REGISTER SPACE MAPPING FOR PTP TRIGGER OUTPUT (12 UNITS, 0X200 – 0X3FF) (CONTINUED)**

I/O Register Offset Location		Register Name	Default Value	Description
16-Bit	8-Bit			
0x396 – 0x397	0x396 0x397	TRIG12_CFG_8	0x0000	Trigger Output Unit 12 Configuration/Control Register8
0x398 – 0x3FF	0x398 0x3FF	Reserved (104-Bytes)	Don't Care	None

**TABLE 4-6: INTERNAL I/O REGISTER SPACE MAPPING FOR PTP EVENT TIME STAMP INPUTS (12 UNITS, 0X400 – 0X5FF)**

I/O Register Offset Location		Register Name	Default Value	Description
16-Bit	8-Bit			
0x400 – 0x401	0x400 0x401	TS_RDY	0x0000	Input Unit Ready Register [11:0]
0x402 – 0x403	0x402 0x403	TS_EN	0x0000	Time stamp Input Unit Enable Register [11:0]
0x404 – 0x405	0x404 0x405	TS_SW_RST	0x0000	Time stamp Input Unit Software Reset Register [11:0]
0x406 – 0x41F	0x406 0x41F	Reserved (26-Bytes)	Don't Care	None
0x420 – 0x421	0x420 0x421	TS1_STATUS	0x0000	Time stamp Input Unit 1 Status Register
0x422 – 0x423	0x422 0x423	TS1_CFG	0x0000	Time stamp Input Unit 1 Configuration/Control Register
0x424 – 0x425	0x424 0x425	TS1_SM- PL1_NSL	0x0000	Time stamp Unit 1 Input Sample Time (1 <sup>st</sup> ) in Nanoseconds Low-Word Register [15:0]
0x426 – 0x427	0x426 0x427	TS1_SM- PL1_NSH	0x0000	Time stamp Unit 1 Input Sample Time (1 <sup>st</sup> ) in Nanoseconds High-Word Register [29:16]
0x428 – 0x429	0x428 0x429	TS1_SM- PL1_SL	0x0000	Time stamp Unit 1 Input Sample Time (1 <sup>st</sup> ) in Seconds Low-Word Register [15:0]
0x42A – 0x42B	0x42A 0x42B	TS1_SM- PL1_SH	0x0000	Time stamp Unit 1 Input Sample Time (1 <sup>st</sup> ) in Seconds High-Word Register [31:16]
0x42C – 0x42D	0x42C 0x42D	TS1_SMPL1_- SUB_NS	0x0000	Time stamp Unit 1 Input Sample Time (1 <sup>st</sup> ) in Sub-Nanoseconds Register [2:0]
0x42E – 0x433	0x42E 0x433	Reserved (6-Bytes)	Don't Care	None
0x434 – 0x435	0x434 0x435	TS1_SM- PL2_NSL	0x0000	Time stamp Unit 1 Input Sample Time (2 <sup>nd</sup> ) in Nanoseconds Low-Word Register [15:0]
0x436 – 0x437	0x436 0x437	TS1_SM- PL2_NSH	0x0000	Time stamp Unit 1 Input Sample Time (2 <sup>nd</sup> ) in Nanoseconds High-Word Register [29:16]
0x438 – 0x439	0x438 0x439	TS1_SM- PL2_SL	0x0000	Time stamp Unit 1 Input Sample Time (2 <sup>nd</sup> ) in Seconds Low-Word Register [15:0]
0x43A – 0x43B	0x43A 0x43B	TS1_SM- PL2_SH	0x0000	Time stamp Unit 1 Input Sample Time (2 <sup>nd</sup> ) in Seconds High-Word Register [31:16]
0x43C – 0x43D	0x43C 0x43D	TS1_SMPL2_- SUB_NS	0x0000	Time stamp Unit 1 Input Sample Time (2 <sup>nd</sup> ) in Sub-Nanoseconds Register [2:0]
0x43E – 0x43F	0x43E 0x43F	Reserved (2-Bytes)	Don't Care	None

# KSZ8441HL/FHL

**TABLE 4-6: INTERNAL I/O REGISTER SPACE MAPPING FOR PTP EVENT TIME STAMP INPUTS (12 UNITS, 0X400 – 0X5FF) (CONTINUED)**

I/O Register Offset Location		Register Name	Default Value	Description
16-Bit	8-Bit			
0x440 – 0x441	0x440 0x441	TS2_STATUS	0x0000	Time stamp Input Unit 2 Status Register
0x442 – 0x443	0x442 0x443	TS2_CFG	0x0000	Time stamp Input Unit 2 Configuration/Control Register
0x444 – 0x445	0x444 0x445	TS2_SM- PL1_NSL	0x0000	Time stamp Unit 2 Input Sample Time (1 <sup>st</sup> ) in Nanoseconds Low-Word Register [15:0]
0x446 – 0x447	0x446 0x447	TS2_SM- PL1_NSH	0x0000	Time stamp Unit 2 Input Sample Time (1 <sup>st</sup> ) in Nanoseconds High-Word Register [29:16]
0x448 – 0x449	0x448 0x449	TS2_SM- PL1_SL	0x0000	Time stamp Unit 2 Input Sample Time (1 <sup>st</sup> ) in Seconds Low-Word Register [15:0]
0x44A – 0x44B	0x44A 0x44B	TS2_SM- PL1_SH	0x0000	Time stamp Unit 2 Input Sample Time (1 <sup>st</sup> ) in Seconds High-Word Register [31:16]
0x44C – 0x44D	0x44C 0x44D	TS2_SMPL1_- SUB_NS	0x0000	Time stamp Unit 2 Input Sample Time (1 <sup>st</sup> ) in Sub-Nanoseconds Register [2:0]
0x44E – 0x453	0x44E 0x453	Reserved (6-Bytes)	Don't Care	None
0x454 – 0x455	0x454 0x455	TS2_SM- PL2_NSL	0x0000	Time stamp Unit 2 Input Sample Time (2nd) in Nanoseconds Low-Word Register [15:0]
0x456 – 0x457	0x456 0x457	TS2_SM- PL2_NSH	0x0000	Time stamp Unit 2 Input Sample Time (2nd) in Nanoseconds High-Word Register [29:16]
0x458 – 0x459	0x458 0x459	TS2_SMP2_SL	0x0000	Time stamp Unit 2 Input Sample Time (2nd) in Seconds Low-Word Register [15:0]
0x45A – 0x45B	0x45A 0x45B	TS2_SM- PL2_SH	0x0000	Time stamp Unit 2 Input Sample Time (2nd) in Seconds High-Word Register [31:16]
0x45C – 0x45D	0x45C 0x45D	TS2_SMPL2_- SUB_NS	0x0000	Time stamp Unit 2 Input Sample Time (2nd) in Sub-Nanoseconds Register [2:0]
0x45E – 0x45F	0x45E 0x45F	Reserved (2-Bytes)	Don't Care	None
0x460 – 0x461	0x460 0x461	TS3_STATUS	0x0000	Time stamp Input Unit 3 Status Register
0x462 – 0x463	0x462 0x463	TS3_CFG	0x0000	Time stamp Input Unit 3 Configuration/Control Register
0x464 – 0x465	0x464 0x465	TS3_SM- PL1_NSL	0x0000	Time stamp Unit 3 Input Sample Time (1 <sup>st</sup> ) in Nanoseconds Low-Word Register [15:0]
0x466 – 0x467	0x466 0x467	TS3_SM- PL1_NSH	0x0000	Time stamp Unit 3 Input Sample Time (1 <sup>st</sup> ) in Nanoseconds High-Word Register [29:16]
0x468 – 0x469	0x468 0x469	TS3_SM- PL1_SL	0x0000	Time stamp Unit 3 Input Sample Time (1 <sup>st</sup> ) in Seconds Low-Word Register [15:0]
0x46A – 0x46B	0x46A 0x46B	TS3_SM- PL1_SH	0x0000	Time stamp Unit 3 Input Sample Time (1 <sup>st</sup> ) in Seconds High-Word Register [31:16]
0x46C – 0x46D	0x46C 0x46D	TS3_SMPL1_- SUB_NS	0x0000	Time stamp Unit 3 Input Sample Time (1 <sup>st</sup> ) in Sub-Nanoseconds Register [2:0]
0x46E – 0x473	0x46E 0x473	Reserved (6-Bytes)	Don't Care	None



**TABLE 4-6: INTERNAL I/O REGISTER SPACE MAPPING FOR PTP EVENT TIME STAMP INPUTS (12 UNITS, 0X400 – 0X5FF) (CONTINUED)**

I/O Register Offset Location		Register Name	Default Value	Description
16-Bit	8-Bit			
0x474 – 0x475	0x474 0x475	TS3_SM- PL2_NSL	0x0000	Time stamp Unit 3 Input Sample Time (2nd) in Nanoseconds Low-Word Register [15:0]
0x476 – 0x477	0x476 0x477	TS3_SM- PL2_NSH	0x0000	Time stamp Unit 3 Input Sample Time (2nd) in Nanoseconds High-Word Register [29:16]
0x478 – 0x479	0x478 0x479	TS3_SMP2_SL	0x0000	Time stamp Unit 3 Input Sample Time (2nd) in Seconds Low-Word Register [15:0]
0x47A – 0x47B	0x47A 0x47B	TS3_SM- PL2_SH	0x0000	Time stamp Unit 3 Input Sample Time (2nd) in Seconds High-Word Register [31:16]
0x47C – 0x47D	0x47C 0x47D	TS3_SMPL2_- SUB_NS	0x0000	Time stamp Unit 3 Input Sample Time (2nd) in Sub-Nanoseconds Register [2:0]
0x47E – 0x47F	0x47E 0x47F	Reserved (2-Bytes)	Don't Care	None
0x480 – 0x481	0x480 0x481	TS4_STATUS	0x0000	Time stamp Input Unit 4 Status Register
0x482 – 0x483	0x482 0x483	TS4_CFG	0x0000	Time stamp Input Unit 4 Configuration/Control Register
0x484 – 0x485	0x484 0x485	TS4_SM- PL1_NSL	0x0000	Time stamp Unit 4 Input Sample Time (1 <sup>st</sup> ) in Nanoseconds Low-Word Register [15:0]
0x486 – 0x487	0x486 0x487	TS4_SM- PL1_NSH	0x0000	Time stamp Unit 4 Input Sample Time (1 <sup>st</sup> ) in Nanoseconds High-Word Register [29:16]
0x488 – 0x489	0x488 0x489	TS4_SM- PL1_SL	0x0000	Time stamp Unit 4 Input Sample Time (1 <sup>st</sup> ) in Seconds Low-Word Register [15:0]
0x48A – 0x48B	0x48A 0x48B	TS4_SM- PL1_SH	0x0000	Time stamp Unit 4 Input Sample Time (1 <sup>st</sup> ) in Seconds High-Word Register [31:16]
0x48C – 0x48D	0x48C 0x48D	TS4_SMPL1_- SUB_NS	0x0000	Time stamp Unit 4 Input Sample Time (1 <sup>st</sup> ) in Sub-Nanoseconds Register [2:0]
0x48E – 0x493	0x48E 0x493	Reserved (6-Bytes)	Don't Care	None
0x494 – 0x495	0x494 0x495	TS4_SM- PL2_NSL	0x0000	Time stamp Unit 4 Input Sample Time (2nd) in Nanoseconds Low-Word Register [15:0]
0x496 – 0x497	0x496 0x497	TS4_SM- PL2_NSH	0x0000	Time stamp Unit 4 Input Sample Time (2nd) in Nanoseconds High-Word Register [29:16]
0x498 – 0x499	0x498 0x499	TS4_SMP2_SL	0x0000	Time stamp Unit 4 Input Sample Time (2nd) in Seconds Low-Word Register [15:0]
0x49A – 0x49B	0x49A 0x49B	TS4_SM- PL2_SH	0x0000	Time stamp Unit 4 Input Sample Time (2nd) in Seconds High-Word Register [31:16]
0x49C – 0x49D	0x49C 0x49D	TS4_SMPL2_- SUB_NS	0x0000	Time stamp Unit 4 Input Sample Time (2nd) in Sub-Nanoseconds Register [2:0]
0x49E – 0x49F	0x49E 0x49F	Reserved (2-Bytes)	Don't Care	None
0x4A0 – 0x4A1	0x4A0 0x4A1	TS5_STATUS	0x0000	Time stamp Input Unit 5 Status Register
0x4A2 – 0x4A3	0x4A2 0x4A3	TS5_CFG	0x0000	Time stamp Input Unit 5 Configuration/Control Register

# KSZ8441HL/FHL

**TABLE 4-6: INTERNAL I/O REGISTER SPACE MAPPING FOR PTP EVENT TIME STAMP INPUTS (12 UNITS, 0X400 – 0X5FF) (CONTINUED)**

I/O Register Offset Location		Register Name	Default Value	Description
16-Bit	8-Bit			
0x4A4 – 0x4A5	0x4A4 0x4A5	TS5_SMPL1_NSL	0x0000	Time stamp Unit 5 Input Sample Time (1 <sup>st</sup> ) in Nanoseconds Low-Word Register [15:0]
0x4A6 – 0x4A7	0x4A6 0x4A7	TS5_SMPL1_NSH	0x0000	Time stamp Unit 5 Input Sample Time (1 <sup>st</sup> ) in Nanoseconds High-Word Register [29:16]
0x4A8 – 0x4A9	0x4A8 0x4A9	TS5_SMPL1_SL	0x0000	Time stamp Unit 5 Input Sample Time (1 <sup>st</sup> ) in Seconds Low-Word Register [15:0]
0x4AA – 0x4AB	0x4AA 0x4AB	TS5_SMPL1_SH	0x0000	Time stamp Unit 5 Input Sample Time (1 <sup>st</sup> ) in Seconds High-Word Register [31:16]
0x4AC – 0x4AD	0x4AC 0x4AD	TS5_SMPL1_SUB_NS	0x0000	Time stamp Unit 5 Input Sample Time (1 <sup>st</sup> ) in Sub-Nanoseconds Register [2:0]
0x4AE – 0x4B3	0x4AE 0x4B3	Reserved (6-Bytes)	Don't Care	None
0x4B4 – 0x4B5	0x4B4 0x4B5	TS5_SMPL2_NSL	0x0000	Time stamp Unit 5 Input Sample Time (2 <sup>nd</sup> ) in Nanoseconds Low-Word Register [15:0]
0x4B6 – 0x4B7	0x4B6 0x4B7	TS5_SMPL2_NSH	0x0000	Time stamp Unit 5 Input Sample Time (2 <sup>nd</sup> ) in Nanoseconds High-Word Register [29:16]
0x4B8 – 0x4B9	0x4B8 0x4B9	TS5_SMP2_SL	0x0000	Time stamp Unit 5 Input Sample Time (2 <sup>nd</sup> ) in Seconds Low-Word Register [15:0]
0x4BA – 0x4BB	0x4BA 0x4BB	TS5_SMPL2_SH	0x0000	Time stamp Unit 5 Input Sample Time (2 <sup>nd</sup> ) in Seconds High-Word Register [31:16]
0x4BC – 0x4BD	0x4BC 0x4BD	TS5_SMPL2_SUB_NS	0x0000	Time stamp Unit 5 Input Sample Time (2 <sup>nd</sup> ) in Sub-Nanoseconds Register [2:0]
0x4BE – 0x4BF	0x4BE 0x4BF	Reserved (2-Bytes)	Don't Care	None
0x4C0 – 0x4C1	0x4C0 0x4C1	TS6_STATUS	0x0000	Time stamp Input Unit 6 Status Register
0x4C2 – 0x4C3	0x4C2 0x4C3	TS6_CFG	0x0000	Time stamp Input Unit 6 Configuration/Control Register
0x4C4 – 0x4C5	0x4C4 0x4C5	TS6_SMPL1_NSL	0x0000	Time stamp Unit 6 Input Sample Time (1 <sup>st</sup> ) in Nanoseconds Low-Word Register [15:0]
0x4C6 – 0x4C7	0x4C6 0x4C7	TS6_SMPL1_NSH	0x0000	Time stamp Unit 6 Input Sample Time (1 <sup>st</sup> ) in Nanoseconds High-Word Register [29:16]
0x4C8 – 0x4C9	0x4C8 0x4C9	TS6_SMPL1_SL	0x0000	Time stamp Unit 6 Input Sample Time (1 <sup>st</sup> ) in Seconds Low-Word Register [15:0]
0x4CA – 0x4CB	0x4CA 0x4CB	TS6_SMPL1_SH	0x0000	Time stamp Unit 6 Input Sample Time (1 <sup>st</sup> ) in Seconds High-Word Register [31:16]
0x4CC – 0x4CD	0x4CC 0x4CD	TS6_SMPL1_SUB_NS	0x0000	Time stamp Unit 6 Input Sample Time (1 <sup>st</sup> ) in Sub-Nanoseconds Register [2:0]
0x4CE – 0x4D3	0x4CE 0x4D3	Reserved (6-Bytes)	Don't Care	None
0x4D4 – 0x4D5	0x4D4 0x4D5	TS6_SMPL2_NSL	0x0000	Time stamp Unit 6 Input Sample Time (2 <sup>nd</sup> ) in Nanoseconds Low-Word Register [15:0]

**TABLE 4-6: INTERNAL I/O REGISTER SPACE MAPPING FOR PTP EVENT TIME STAMP INPUTS (12 UNITS, 0X400 – 0X5FF) (CONTINUED)**

I/O Register Offset Location		Register Name	Default Value	Description
16-Bit	8-Bit			
0x4D6 – 0x4D7	0x4D6 0x4D7	TS6_SM- PL2_NSH	0x0000	Time stamp Unit 6 Input Sample Time (2nd) in Nanoseconds High-Word Register [29:16]
0x4D8 – 0x4D9	0x4D8 0x4D9	TS6_SMP2_SL	0x0000	Time stamp Unit 6 Input Sample Time (2nd) in Seconds Low-Word Register [15:0]
0x4DA – 0x4DB	0x4DA 0x4DB	TS6_SM- PL2_SH	0x0000	Time stamp Unit 6 Input Sample Time (2nd) in Seconds High-Word Register [31:16]
0x4DC – 0x4DD	0x4DC 0x4DD	TS6_SMPL2_- SUB_NS	0x0000	Time stamp Unit 6 Input Sample Time (2nd) in Sub-Nanoseconds Register [2:0]
0x4DE – 0x4DF	0x4DE 0x4DF	Reserved (2-Bytes)	Don't Care	None
0x4E0 – 0x4E1	0x4E0 0x4E1	TS7_STATUS	0x0000	Time stamp Input Unit 7 Status Register
0x4E2 – 0x4E3	0x4E2 0x4E3	TS7_CFG	0x0000	Time stamp Input Unit 7 Configuration/Control Register
0x4E4 – 0x4E5	0x4E4 0x4E5	TS7_SM- PL1_NSL	0x0000	Time stamp Unit 7 Input Sample Time (1 <sup>st</sup> ) in Nanoseconds Low-Word Register [15:0]
0x4E6 – 0x4E7	0x4E6 0x4E7	TS7_SM- PL1_NSH	0x0000	Time stamp Unit 7 Input Sample Time (1 <sup>st</sup> ) in Nanoseconds High-Word Register [29:16]
0x4E8 – 0x4E9	0x4E8 0x4E9	TS7_SM- PL1_SL	0x0000	Time stamp Unit 7 Input Sample Time (1 <sup>st</sup> ) in Seconds Low-Word Register [15:0]
0x4EA – 0x4EB	0x4EA 0x4EB	TS7_SM- PL1_SH	0x0000	Time stamp Unit 7 Input Sample Time (1 <sup>st</sup> ) in Seconds High-Word Register [31:16]
0x4EC – 0x4ED	0x4EC 0x4ED	TS7_SMPL1_- SUB_NS	0x0000	Time stamp Unit 7 Input Sample Time (1 <sup>st</sup> ) in Sub-Nanoseconds Register [2:0]
0x4EE – 0x4F3	0x4EE 0x4F3	Reserved (6-Bytes)	Don't Care	None
0x4F4 – 0x4F5	0x4F4 0x4F5	TS7_SM- PL2_NSL	0x0000	Time stamp Unit 7 Input Sample Time (2nd) in Nanoseconds Low-Word Register [15:0]
0x4F6 – 0x4F7	0x4F6 0x4F7	TS7_SM- PL2_NSH	0x0000	Time stamp Unit 7 Input Sample Time (2nd) in Nanoseconds High-Word Register [29:16]
0x4F8 – 0x4F9	0x4F8 0x4F9	TS7_SMP2_SL	0x0000	Time stamp Unit 7 Input Sample Time (2nd) in Seconds Low-Word Register [15:0]
0x4FA – 0x4FB	0x4FA 0x4FB	TS7_SM- PL2_SH	0x0000	Time stamp Unit 7 Input Sample Time (2nd) in Seconds High-Word Register [31:16]
0x4FC – 0x4FD	0x4FC 0x4FD	TS7_SMPL2_- SUB_NS	0x0000	Time stamp Unit 7 Input Sample Time (2nd) in Sub-Nanoseconds Register [2:0]
0x4FE – 0x4FF	0x4FE 0x4FF	Reserved (2-Bytes)	Don't Care	None
0x500 – 0x501	0x500 0x501	TS8_STATUS	0x0000	Time stamp Input Unit 8 Status Register
0x502 – 0x503	0x502 0x503	TS8_CFG	0x0000	Time stamp Input Unit 8 Configuration/Control Register
0x504 – 0x505	0x504 0x505	TS8_SM- PL1_NSL	0x0000	Time stamp Unit 8 Input Sample Time (1 <sup>st</sup> ) in Nanoseconds Low-Word Register [15:0]

# KSZ8441HL/FHL

**TABLE 4-6: INTERNAL I/O REGISTER SPACE MAPPING FOR PTP EVENT TIME STAMP INPUTS (12 UNITS, 0X400 – 0X5FF) (CONTINUED)**

I/O Register Offset Location		Register Name	Default Value	Description
16-Bit	8-Bit			
0x506 – 0x507	0x506 0x507	TS8_SM- PL1_NSH	0x0000	Time stamp Unit 8 Input Sample Time (1 <sup>st</sup> ) in Nanoseconds High-Word Register [29:16]
0x508 – 0x509	0x508 0x509	TS8_SM- PL1_SL	0x0000	Time stamp Unit 8 Input Sample Time (1 <sup>st</sup> ) in Seconds Low-Word Register [15:0]
0x50A – 0x50B	0x50A 0x50B	TS8_SM- PL1_SH	0x0000	Time stamp Unit 8 Input Sample Time (1 <sup>st</sup> ) in Seconds High-Word Register [31:16]
0x50C – 0x50D	0x50C 0x50D	TS8_SMPL1_- SUB_NS	0x0000	Time stamp Unit 8 Input Sample Time (1 <sup>st</sup> ) in Sub-Nanoseconds Register [2:0]
0x50E – 0x513	0x50E 0x513	Reserved (6-Bytes)	Don't Care	None
0x514 – 0x515	0x514 0x515	TS8_SM- PL2_NSL	0x0000	Time stamp Unit 8 Input Sample Time (2 <sup>nd</sup> ) in Nanoseconds Low-Word Register [15:0]
0x516 – 0x517	0x516 0x517	TS8_SM- PL2_NSH	0x0000	Time stamp Unit 8 Input Sample Time (2 <sup>nd</sup> ) in Nanoseconds High-Word Register [29:16]
0x518 – 0x519	0x518 0x519	TS8_SMP2_SL	0x0000	Time stamp Unit 8 Input Sample Time (2 <sup>nd</sup> ) in Seconds Low-Word Register [15:0]
0x51A – 0x51B	0x51A 0x51B	TS8_SM- PL2_SH	0x0000	Time stamp Unit 8 Input Sample Time (2 <sup>nd</sup> ) in Seconds High-Word Register [31:16]
0x51C – 0x51D	0x51C 0x51D	TS8_SMPL2_- SUB_NS	0x0000	Time stamp Unit 8 Input Sample Time (2 <sup>nd</sup> ) in Sub-Nanoseconds Register [2:0]
0x51E – 0x51F	0x51E 0x51F	Reserved (2-Bytes)	Don't Care	None
0x520 – 0x521	0x520 0x521	TS9_STATUS	0x0000	Time stamp Input Unit 9 Status Register
0x522 – 0x523	0x522 0x523	TS9_CFG	0x0000	Time stamp Input Unit 9 Configuration/Control Register
0x524 – 0x525	0x524 0x525	TS9_SM- PL1_NSL	0x0000	Time stamp Unit 9 Input Sample Time (1 <sup>st</sup> ) in Nanoseconds High-Word Register [15:0]
0x526 – 0x527	0x526 0x527	TS9_SM- PL1_NSH	0x0000	Time stamp Unit 9 Input Sample Time (1 <sup>st</sup> ) in Nanoseconds High-Word Register [29:16]
0x528 – 0x529	0x528 0x529	TS9_SM- PL1_SL	0x0000	Time stamp Unit 9 Input Sample Time (1 <sup>st</sup> ) in Seconds High-Word Register [15:0]
0x52A – 0x52B	0x52A 0x52B	TS9_SM- PL1_SH	0x0000	Time stamp Unit 9 Input Sample Time (1 <sup>st</sup> ) in Seconds High-Word Register [31:16]
0x52C – 0x52D	0x52C 0x52D	TS9_SMPL1_- SUB_NS	0x0000	Time stamp Unit 9 Input Sample Time (1 <sup>st</sup> ) in Sub-Nanoseconds Register [2:0]
0x52E – 0x533	0x52E 0x533	Reserved (6-Bytes)	Don't Care	None
0x534 – 0x535	0x534 0x535	TS9_SM- PL2_NSL	0x0000	Time stamp Unit 9 Input Sample Time (2 <sup>nd</sup> ) in Nanoseconds Low-Word Register [15:0]
0x536 – 0x537	0x536 0x537	TS9_SM- PL2_NSH	0x0000	Time stamp Unit 9 Input Sample Time (2 <sup>nd</sup> ) in Nanoseconds High-Word Register [29:16]
0x538 – 0x539	0x538 0x539	TS9_SMP2_SL	0x0000	Time stamp Unit 9 Input Sample Time (2 <sup>nd</sup> ) in Seconds Low-Word Register [15:0]

**TABLE 4-6: INTERNAL I/O REGISTER SPACE MAPPING FOR PTP EVENT TIME STAMP INPUTS (12 UNITS, 0X400 – 0X5FF) (CONTINUED)**

I/O Register Offset Location		Register Name	Default Value	Description
16-Bit	8-Bit			
0x53A – 0x53B	0x53A 0x53B	TS9_SM- PL2_SH	0x0000	Time stamp Unit 9 Input Sample Time (2nd) in Seconds High-Word Register [31:16]
0x53C – 0x53D	0x53C 0x53D	TS9_SMPL2_- SUB_NS	0x0000	Time stamp Unit 9 Input Sample Time (2nd) in Sub-Nanoseconds Register [2:0]
0x53E – 0x53F	0x53E 0x53F	Reserved (2-Bytes)	Don't Care	None
0x540 – 0x541	0x540 0x541	TS10_STATUS	0x0000	Time stamp Input Unit 10 Status Register
0x542 – 0x543	0x542 0x543	TS10_CFG	0x0000	Time stamp Input Unit 10 Configuration/ Control Register
0x544 – 0x545	0x544 0x545	TS10_SM- PL1_NSL	0x0000	Time stamp Unit 10 Input Sample Time (1 <sup>st</sup> ) in Nanoseconds Low-Word Register [15:0]
0x546 – 0x547	0x546 0x547	TS10_SM- PL1_NSH	0x0000	Time stamp Unit 10 Input Sample Time (1 <sup>st</sup> ) in Nanoseconds High-Word Register [29:16]
0x548 – 0x549	0x548 0x549	TS10_SM- PL1_SL	0x0000	Time stamp Unit 10 Input Sample Time (1 <sup>st</sup> ) in Seconds Low-Word Register [15:0]
0x54A – 0x54B	0x54A 0x54B	TS10_SM- PL1_SH	0x0000	Time stamp Unit 10 Input Sample Time (1 <sup>st</sup> ) in Seconds High-Word Register [31:16]
0x54C – 0x54D	0x54C 0x54D	TS10_SMPL1_- SUB_NS	0x0000	Time stamp Unit 10 Input Sample Time (1 <sup>st</sup> ) in Sub-Nanoseconds Register [2:0]
0x54E – 0x553	0x54E 0x553	Reserved (6-Bytes)	Don't Care	None
0x554 – 0x555	0x554 0x555	TS10_SM- PL2_NSL	0x0000	Time stamp Unit 10 Input Sample Time (2nd) in Nanoseconds Low-Word Register [15:0]
0x556 – 0x557	0x556 0x557	TS10_SM- PL2_NSH	0x0000	Time stamp Unit 10 Input Sample Time (2nd) in Nanoseconds High-Word Register [29:16]
0x558 – 0x559	0x558 0x559	TS10_SMP2_S L	0x0000	Time stamp Unit 10 Input Sample Time (2nd) in Seconds Low-Word Register [15:0]
0x55A – 0x55B	0x55A 0x55B	TS10_SM- PL2_SH	0x0000	Time stamp Unit 10 Input Sample Time (2nd) in Seconds High-Word Register [31:16]
0x55C – 0x55D	0x55C 0x55D	TS10_SMPL2_- SUB_NS	0x0000	Time stamp Unit 10 Input Sample Time (2nd) in Sub-Nanoseconds Register [2:0]
0x55E – 0x55F	0x55E 0x55F	Reserved (2-Bytes)	Don't Care	None
0x560 – 0x561	0x560 0x561	TS11_STATUS	0x0000	Time stamp Input Unit 11 Status Register
0x562 – 0x563	0x562 0x563	TS11_CFG	0x0000	Time stamp Input Unit 11 Configuration/ Control Register
0x564 – 0x565	0x564 0x565	TS11_SM- PL1_NSL	0x0000	Time stamp Unit 11 Input Sample Time (1 <sup>st</sup> ) in Nanoseconds Low-Word Register [15:0]
0x566 – 0x567	0x566 0x567	TS11_SM- PL1_NSH	0x0000	Time stamp Unit 11 Input Sample Time (1 <sup>st</sup> ) in Nanoseconds High-Word Register [29:16]

# KSZ8441HL/FHL

**TABLE 4-6: INTERNAL I/O REGISTER SPACE MAPPING FOR PTP EVENT TIME STAMP INPUTS (12 UNITS, 0X400 – 0X5FF) (CONTINUED)**

I/O Register Offset Location		Register Name	Default Value	Description
16-Bit	8-Bit			
0x568 – 0x569	0x568 0x569	TS11_SM- PL1_SL	0x0000	Time stamp Unit 11 Input Sample Time (1 <sup>st</sup> ) in Seconds Low-Word Register [15:0]
0x56A – 0x56B	0x56A 0x56B	TS11_SM- PL1_SH	0x0000	Time stamp Unit 11 Input Sample Time (1 <sup>st</sup> ) in Seconds High-Word Register [31:16]
0x56C – 0x56D	0x56C 0x56D	TS11_SMPL1_- SUB_NS	0x0000	Time stamp Unit 11 Input Sample Time (1 <sup>st</sup> ) in Sub-Nanoseconds Register [2:0]
0x56E – 0x573	0x56E 0x573	Reserved (6-Bytes)	Don't Care	None
0x574 – 0x575	0x574 0x575	TS11_SM- PL2_NSL	0x0000	Time stamp Unit 11 Input Sample Time (2 <sup>nd</sup> ) in Nanoseconds Low-Word Register [15:0]
0x576 – 0x577	0x576 0x577	TS11_SM- PL2_NSH	0x0000	Time stamp Unit 11 Input Sample Time (2 <sup>nd</sup> ) in Nanoseconds High-Word Register [29:16]
0x578 – 0x579	0x578 0x579	TS11_SMP2_S L	0x0000	Time stamp Unit 11 Input Sample Time (2 <sup>nd</sup> ) in Seconds Low-Word Register [15:0]
0x57A – 0x57B	0x57A 0x57B	TS11_SM- PL2_SH	0x0000	Time stamp Unit 11 Input Sample Time (2 <sup>nd</sup> ) in Seconds High-Word Register [31:16]
0x57C – 0x57D	0x57C 0x57D	TS11_SMPL2_- SUB_NS	0x0000	Time stamp Unit 11 Input Sample Time (2 <sup>nd</sup> ) in Sub-Nanoseconds Register [2:0]
0x57E – 0x57F	0x57E 0x57F	Reserved (2-Bytes)	Don't Care	None
0x580 – 0x581	0x580 0x581	TS12_STATUS	0x0000	Time stamp Input Unit 12 Status Register
0x582 – 0x583	0x582 0x583	TS12_CFG	0x0000	Time stamp Input Unit 12 Configuration/ Control Register
0x584 – 0x585	0x584 0x585	TS12_SM- PL1_NSL	0x0000	Time stamp Unit 12 Input Sample Time (1 <sup>st</sup> ) in Nanoseconds Low-Word Register [15:0]
0x586 – 0x587	0x586 0x587	TS12_SM- PL1_NSH	0x0000	Time stamp Unit 12 Input Sample Time (1 <sup>st</sup> ) in Nanoseconds High-Word Register [29:16]
0x588 – 0x589	0x588 0x589	TS12_SM- PL1_SL	0x0000	Time stamp Unit 12 Input Sample Time (1 <sup>st</sup> ) in Seconds Low-Word Register [15:0]
0x58A – 0x58B	0x58A 0x58B	TS12_SM- PL1_SH	0x0000	Time stamp Unit 12 Input Sample Time (1 <sup>st</sup> ) in Seconds High-Word Register [31:16]
0x58C – 0x58D	0x58C 0x58D	TS12_SMPL1_- SUB_NS	0x0000	Time stamp Unit 12 Input Sample Time (1 <sup>st</sup> ) in Sub-Nanoseconds Register [2:0]
0x58E – 0x593	0x58E 0x593	Reserved (6-Bytes)	Don't Care	None
0x594 – 0x595	0x594 0x595	TS12_SM- PL2_NSL	0x0000	Time stamp Unit 12 Input Sample Time (2 <sup>nd</sup> ) in Nanoseconds Low-Word Register [15:0]
0x596 – 0x597	0x596 0x597	TS12_SM- PL2_NSH	0x0000	Time stamp Unit 12 Input Sample Time (2 <sup>nd</sup> ) in Nanoseconds High-Word Register [29:16]
0x598 – 0x599	0x598 0x599	TS12_SMP2_S L	0x0000	Time stamp Unit 12 Input Sample Time (2 <sup>nd</sup> ) in Seconds Low-Word Register [15:0]

**TABLE 4-6: INTERNAL I/O REGISTER SPACE MAPPING FOR PTP EVENT TIME STAMP INPUTS (12 UNITS, 0X400 – 0X5FF) (CONTINUED)**

I/O Register Offset Location		Register Name	Default Value	Description
16-Bit	8-Bit			
0x59A – 0x59B	0x59A 0x59B	TS12_SM- PL2_SH	0x0000	Time stamp Unit 12 Input Sample Time (2nd) in Seconds High-Word Register [31:16]
0x59C – 0x59D	0x59C 0x59D	TS12_SMPL2_- SUB_NS	0x0000	Time stamp Unit 12 Input Sample Time (2nd) in Sub-Nanoseconds Register [2:0]
0x59E – 0x5A3	0x59E 0x5A3	Reserved (6-Bytes)	Don't Care	None
0x5A4 – 0x5A5	0x5A4 0x5A5	TS12_SM- PL3_NSL	0x0000	Time stamp Unit 12 Input Sample Time (3rd) in Nanoseconds Low-Word Register [15:0]
0x5A6 – 0x5A7	0x5A6 0x5A7	TS12_SM- PL3_NSH	0x0000	Time stamp Unit 12 Input Sample Time (3rd) in Nanoseconds High-Word Register [29:16]
0x5A8 – 0x5A9	0x5A8 0x5A9	TS12_SM- PL3_SL	0x0000	Time stamp Unit 12 Input Sample Time (3rd) in Seconds Low-Word Register [15:0]
0x5AA – 0x5AB	0x5AA 0x5AB	TS12_SM- PL3_SH	0x0000	Time stamp Unit 12 Input Sample Time (3rd) in Seconds High-Word Register [31:16]
0x5AC – 0x5AD	0x5AC 0x5AD	TS12_SMPL3_- SUB_NS	0x0000	Time stamp Unit 12 Input Sample Time (3rd) in Sub-Nanoseconds Register [2:0]
0x5AE – 0x5B3	0x5AE 0x5B3	Reserved (6-Bytes)	Don't Care	None
0x5B4 – 0x5B5	0x5B4 0x5B5	TS12_SM- PL4_NSL	0x0000	Time stamp Unit 12 Input Sample Time (4th) in Nanoseconds Low-Word Register [15:0]
0x5B6 – 0x5B7	0x5B6 0x5B7	TS12_SM- PL4_NSH	0x0000	Time stamp Unit 12 Input Sample Time (4th) in Nanoseconds High-Word Register [29:16]
0x5B8 – 0x5B9	0x5B8 0x5B9	TS12_SM- PL4_SL	0x0000	Time stamp Unit 12 Input Sample Time (4th) in Seconds Low-Word Register [15:0]
0x5BA – 0x5BB	0x5BA 0x5BB	TS12_SM- PL4_SH	0x0000	Time stamp Unit 12 Input Sample Time (4th) in Seconds High-Word Register [31:16]
0x5BC – 0x5BD	0x5BC 0x5BD	TS12_SMPL4_- SUB_NS	0x0000	Time stamp Unit 12 Input Sample Time (4th) in Sub-Nanoseconds Register [2:0]
0x5BE – 0x5C3	0x5BE 0x5C3	Reserved (6-Bytes)	Don't Care	None
0x5C4 – 0x5C5	0x5C4 0x5C5	TS12_SM- PL5_NSL	0x0000	Time stamp Unit 12 Input Sample Time (5th) in Nanoseconds Low-Word Register [15:0]
0x5C6 – 0x5C7	0x5C6 0x5C7	TS12_SM- PL5_NSH	0x0000	Time stamp Unit 12 Input Sample Time (5th) in Nanoseconds High-Word Register [29:16]
0x5C8 – 0x5C9	0x5C8 0x5C9	TS12_SM- PL5_SL	0x0000	Time stamp Unit 12 Input Sample Time (5th) in Seconds Low-Word Register [15:0]
0x5CA – 0x5CB	0x5CA 0x5CB	TS12_SM- PL5_SH	0x0000	Time stamp Unit 12 Input Sample Time (5th) in Seconds High-Word Register [31:16]

# KSZ8441HL/FHL

**TABLE 4-6: INTERNAL I/O REGISTER SPACE MAPPING FOR PTP EVENT TIME STAMP INPUTS (12 UNITS, 0X400 – 0X5FF) (CONTINUED)**

I/O Register Offset Location		Register Name	Default Value	Description
16-Bit	8-Bit			
0x5CC – 0x5CD	0x5CC 0x5CD	TS12_SMPL5_ SUB_NS	0x0000	Time stamp Unit 12 Input Sample Time (5th) in Sub-Nanoseconds Register [2:0]
0x5CE – 0x5D3	0x5CE 0x5D3	Reserved (6-Bytes)	Don't Care	None
0x5D4 – 0x5D5	0x5D4 0x5D5	TS12_SM- PL6_NSL	0x0000	Time stamp Unit 12 Input Sample Time (6th) in Nanoseconds Low-Word Register [15:0]
0x5D6 – 0x5D7	0x5D6 0x5D7	TS12_SM- PL6_NSH	0x0000	Time stamp Unit 12 Input Sample Time (6th) in Nanoseconds High-Word Register [29:16]
0x5D8 – 0x5D9	0x5D8 0x5D9	TS12_SM- PL6_SL	0x0000	Time stamp Unit 12 Input Sample Time (6th) in Seconds Low-Word Register [15:0]
0x5DA – 0x5DB	0x5DA 0x5DB	TS12_SM- PL6_SH	0x0000	Time stamp Unit 12 Input Sample Time (6th) in Seconds High-Word Register [31:16]
0x5DC – 0x5DD	0x5DC 0x5DD	TS12_SMPL6_ SUB_NS	0x0000	Time stamp Unit 12 Input Sample Time (6th) in Sub-Nanoseconds Register [2:0]
0x5DE – 0x5E3	0x5DE 0x5E3	Reserved (6-Bytes)	Don't care	None
0x5E4 – 0x5E5	0x5E4 0x5E5	TS12_SM- PL7_NSL	0x0000	Time stamp Unit 12 Input Sample Time (7th) in Nanoseconds Low-Word Register [15:0]
0x5E6 – 0x5E7	0x5E6 0x5E7	TS12_SM- PL7_NSH	0x0000	Time stamp Unit 12 Input Sample Time (7th) in Nanoseconds High-Word Register [29:16]
0x5E8 – 0x5E9	0x5E8 0x5E9	TS12_SM- PL7_SL	0x0000	Time stamp Unit 12 Input Sample Time (7th) in Seconds Low-Word Register [15:0]
0x5EA – 0x5EB	0x5EA 0x5EB	TS12_SM- PL7_SH	0x0000	Time stamp Unit 12 Input Sample Time (7th) in Seconds High-Word Register [31:16]
0x5EC – 0x5ED	0x5EC 0x5ED	TS12_SMPL7_ SUB_NS	0x0000	Time stamp Unit 12 Input Sample Time (7th) in Sub-Nanoseconds Register [2:0]
0x5EE – 0x5F3	0x5EE 0x5F3	Reserved (6-Bytes)	Don't Care	None
0x5F4 – 0x5F5	0x5F4 0x5F5	TS12_SM- PL8_NSL	0x0000	Time stamp Unit 12 Input Sample Time (8th) in Nanoseconds Low-Word Register [15:0]
0x5F6 – 0x5F7	0x5F6 0x5F7	TS12_SM- PL8_NSH	0x0000	Time stamp Unit 12 Input Sample Time (8th) in Nanoseconds High-Word Register [29:16]
0x5F8 – 0x5F9	0x5F8 0x5F9	TS12_SM- PL8_SL	0x0000	Time stamp Unit 12 Input Sample Time (8th) in Seconds Low-Word Register [15:0]
0x5FA – 0x5FB	0x5FA 0x5FB	TS12_SM- PL8_SH	0x0000	Time stamp Unit 12 Input Sample Time (8th) in Seconds High-Word Register [31:16]
0x5FC – 0x5FD	0x5FC 0x5FD	TS12_SMPL8_ SUB_NS	0x0000	Time stamp Unit 12 Input Sample Time (8th) in Sub-Nanoseconds Register [2:0]



**TABLE 4-6: INTERNAL I/O REGISTER SPACE MAPPING FOR PTP EVENT TIME STAMP INPUTS (12 UNITS, 0X400 – 0X5FF) (CONTINUED)**

I/O Register Offset Location		Register Name	Default Value	Description
16-Bit	8-Bit			
0x5FE – 0x5FF	0x5FE 0x5FF	Reserved (2-Bytes)	Don't Care	None

**TABLE 4-7: INTERNAL I/O REGISTER SPACE MAPPING FOR PTP 1588 CLOCK AND GLOBAL CONTROL (0X600 – 0X7FF)**

I/O Register Offset Location		Register Name	Default Value	Description
16-Bit	8-Bit			
0x600 – 0x601	0x600 0x601	PTP_CLK_CTL	0x0002	PTP Clock Control Register [6:0]
0x602 – 0x603	0x602 0x603	Reserved (2-Bytes)	Don't care	None
0x604 – 0x605	0x604 0x605	PTP_RTC_NSL	0x0000	PTP Real Time Clock in Nanoseconds Low-Word Register [15:0]
0x606 – 0x607	0x606 0x607	PTP_RTC_NSH	0x0000	PTP Real Time Clock in Nanoseconds High-Word Register [31:16]
0x608 – 0x609	0x608 0x609	PTP_RTC_SL	0x0000	PTP Real Time Clock in Seconds Low-Word Register [15:0]
0x60A – 0x60B	0x60A 0x60B	PTP_RTC_SH	0x0000	PTP Real Time Clock in Seconds High-Word Register [31:16]
0x60C – 0x60D	0x60C 0x60D	PTP_RT-C_PHASE	0x0000	PTP Real Time Clock in Phase Register [2:0]
0x60E – 0x60F	0x60E 0x60F	Reserved (2-Bytes)	Don't Care	None
0x610 – 0x611	0x610 0x611	PTP_SNS_RATE_L	0x0000	PTP Sub-nanosecond Rate Low-Word Register [15:0]
0x612 – 0x613	0x612 0x613	PTP_SNS_RATE_H	0x0000	PTP Sub-nanosecond Rate High-Word [29:16] and Configuration Register
0x614 – 0x615	0x614 0x615	PTP_TEMP_ADJ_DUR_L	0x0000	PTP Temporary Adjustment Mode Duration Low-Word Register [15:0]
0x616 – 0x617	0x616 0x617	PTP_TEMP_ADJ_DUR_H	0x0000	PTP Temporary Adjustment Mode Duration High-Word Register [31:16]
0x618 – 0x61F	0x618 0x61F	Reserved (8-Bytes)	Don't Care	None
0x620 – 0x621	0x620 0x621	PTP_MSG_CFG_1	0x0059	PTP Message Configuration 1 Register [7:0]
0x622 – 0x623	0x622 0x623	PTP_MSG_CFG_2	0x0404	PTP Message Configuration 2 Register [10:0]
0x624 – 0x625	0x624 0x625	PTP_DOMAIN_VER	0x0200	PTP Domain and Version Register [11:0]
0x626 – 0x63F	0x626 0x63F	Reserved (26-Bytes)	Don't Care	None
0x640 – 0x641	0x640 0x641	PTP_P1_RX_LATENCY	0x019F	PTP Port 1 Receive Latency Register [15:0]
0x642 – 0x643	0x642 0x643	PTP_P1_TX_LATENCY	0x002D	PTP Port 1 Transmit Latency Register [15:0]
0x644 – 0x645	0x644 0x645	PTP_P1_ASYM_COR	0x0000	PTP Port 1 Asymmetry Correction Register [15:0]

# KSZ8441HL/FHL

**TABLE 4-7: INTERNAL I/O REGISTER SPACE MAPPING FOR PTP 1588 CLOCK AND GLOBAL CONTROL (0X600 – 0X7FF) (CONTINUED)**

I/O Register Offset Location		Register Name	Default Value	Description
16-Bit	8-Bit			
0x646 – 0x647	0x646 0x647	PTP_P1_LINK_DLY	0x0000	PTP Port 1 Link Delay Register [15:0]
0x648 – 0x649	0x648 0x649	P1_XD- LY_REQ_TSL	0x0000	PTP Port 1 Egress Time stamp Low-Word for Pdelay_REQ and Delay_REQ Frames Register [15:0]
0x64A – 0x64B	0x64A 0x64B	P1_XD- LY_REQ_TSH	0x0000	PTP Port 1 Egress Time stamp High-Word for Pdelay_REQ and Delay_REQ Frames Register [31:16]
0x64C – 0x64D	0x64C 0x64D	P1_SYNC_TSL	0x0000	PTP Port 1 Egress Time stamp Low-Word for SYNC Frame Register [15:0]
0x64E – 0x64F	0x64E 0x64F	P1_SYNC_TSH	0x0000	PTP Port 1 Egress Time stamp High-Word for SYNC Frame Register [31:16]
0x650 – 0x651	0x650 0x651	P1_PDLY_RE- SP_TSL	0x0000	PTP Port 1 Egress Time stamp Low-Word for Pdelay_resp Frame Register [15:0]
0x652 – 0x653	0x652 0x653	P1_PDLY_RE- SP_TSH	0x0000	PTP Port 1 Egress Time stamp High-Word for Pdelay_resp Frame Register [31:16]
0x654 – 0x67F	0x654 0x67F	Reserved (44-Bytes)	Don't Care	None
0x680 – 0x681	0x680 0x681	GPIO_MONI- TOR	0x0000	PTP GPIO Monitor Register [11:0]
0x682 – 0x683	0x682 0x683	GPIO_OEN	0x0000	PTP GPIO Output Enable Register [11:0]
0x684 – 0x687	0x684 0x687	Reserved (4-Bytes)	Don't Care	None
0x688 – 0x689	0x688 0x689	PTP_TRIG_IS	0x0000	PTP Trigger Unit Interrupt Status Register
0x68A – 0x68B	0x68A 0x68B	PTP_TRIG_IE	0x0000	PTP Trigger Unit Interrupt Enable Register
0x68C – 0x68D	0x68C 0x68D	PTP_TS_IS	0x0000	PTP Time stamp Unit Interrupt Status Register
0x68E – 0x68F	0x68E 0x68F	PTP_TS_IE	0x0000	PTP Time stamp Unit Interrupt Enable Register
0x690 – 0x733	0x690 0x733	Reserved (164-Bytes)	Don't Care	None
0x734 – 0x735	0x734 0x735	DSP_CNTRL_6	0x3020	DSP Control 1 Register
0x736 – 0x747	0x736 0x747	Reserved (18-Bytes)	Don't Care	None
0x748 – 0x749	0x748 0x749	ANA_CNTRL_1	0x0000	Analog Control 1 Register
0x74A – 0x74B	0x74A 0x74B	Reserved (2-Bytes)	Don't Care	None
0x74C – 0x74D	0x74C 0x74D	ANA_CNTRL_3	0x0000	Analog Control 3 Register
0x74E – 0x7FF	0x74E 0x7FF	Reserved (178-Bytes)	Don't Care	None

## 4.2 Register Bit Definitions

The section provides details of the bit definitions for the registers summarized in the previous section. Writing to a bit or register defined as reserved could cause unpredictable results. If it is necessary to write to registers that contain both writable and reserved bits in the same register, the user should first read back the reserved bits (RO or RW), then “OR” the desired settable bits with the value read and write back the “ORed” value back to the register.

Bit Type Definition:

- RO = Read only.
- WO = Write only.
- RW = Read/Write.
- SC = Self-Clear.
- W1C = Write “1” to Clear (Write a “1” to clear this bit).

### 4.2.1 INTERNAL I/O REGISTER SPACE MAPPING FOR SWITCH CONTROL AND CONFIGURATION (0X000 – 0X0FF)

#### 4.2.1.1 Chip ID and Enable Register (0x000 – 0x001): CIDER

This register contains the chip ID and switch-enable control.

**TABLE 4-8: CHIP ID AND ENABLE REGISTER (0X000 – 0X001): CIDER**

Bit	Default	R/W	Description
15 – 8	0x84	RO	<b>Family ID</b> Chip family ID.
7 – 4	0x3	RO	<b>Chip ID</b> 0x1 is assigned to KSZ8441.
3 – 1	001	RO	<b>Revision ID</b> Chip revision ID.
0	1	RW	<b>Start Switch</b> 1 = Start the chip. 0 = Switch is disabled.

#### 4.2.1.2 General Global Control Register 1 (0x002 – 0x003): GGCR1

This register contains global control bits for the switch function.

**TABLE 4-9: GENERAL GLOBAL CONTROL REGISTER 1 (0X002 – 0X003): GGCR1**

Bit	Default	R/W	Description
15	0	RW	<b>Pass All Frames</b> 1 = Pass to the host all packets including bad ones. Used solely for debugging purposes. Works in conjunction with sniffer mode only. 0 = Do not pass bad frames.
14	0	RW	Reserved
13	1	RW	<b>IEEE 802.3x Transmit Direction Flow Control Enable</b> 1 = Enables transmit direction flow control feature. 0 = Disable transmit direction flow control feature. The switch will not generate any flow control packets.
12	1	RW	<b>IEEE 802.3x Receive Direction Flow Control Enable</b> 1 = Enables receive direction flow control feature. 0 = Disable receive direction flow control feature. The switch will not react to any received flow control packets.
11	0	RW	<b>Frame Length Field Check</b> 1 = Enable checking frame length field in the IEEE packets. If the actual length does not match, the packet will be dropped (for Length/Type field < 1500). 0 = Disable checking frame length field in the IEEE packets.

# KSZ8441HL/FHL

**TABLE 4-9: GENERAL GLOBAL CONTROL REGISTER 1 (0X002 – 0X003): GGCR1 (CONTINUED)**

Bit	Default	R/W	Description
10 - 9	10	RW	Reserved
8	0	RW	<b>Aggressive Back-Off Enable</b> 1 = Enable more aggressive back-off algorithm in half-duplex mode to enhance performance. This is not an IEEE standard.
7 - 6	01	RW	Reserved
5	0	RW	<b>Enable Flow Control when Exceeding Ingress Limit</b> 1 = Flow control frame will be sent to link partner when exceeding the ingress rate limit. 0 = Frame will be dropped when exceeding the ingress rate limit.
4	1	RW	<b>Receive 2K Byte Packets Enable</b> 1 = Enable packet length up to 2K bytes. While set, GGCR2 bits[2,1] will have no effect. 0 = Discard packet if packet length is greater than 2000 bytes.
3 - 0	0	RW	Reserved

4.2.1.3 0x004 – 0x00D: Reserved

4.2.1.4 General Global Control Register 7 (0x00E – 0x00F): GGCR7

This register contains global control bits for the switch function.

**TABLE 4-10: GENERAL GLOBAL CONTROL REGISTER 7 (0X00E – 0X00F): SGCR7**

Bit	Default	R/W	Description		
15 – 10	0x02	RW	Reserved		
9 – 8	0x0	RW	<b>Port 1 LED Mode</b> When read, these two bits provide the current setting of the LED display mode for P1LED1 and P1LED0 as defined as below. Reg. 0x06C – 0x06D, bits [14:12] determine if this automatic functionality is utilized or if the Port 1 LEDs are controlled by the local host processor.		
			<b>LED Mode</b>	<b>P1LED1</b>	<b>P1LED0</b>
			00	Speed	Link and Activity
			01	Activity	Link
			10	Full-Duplex	Link and Activity
11	Full-Duplex	Link			
7	0	RW	Reserved		
6 – 5	01 or 10	RW	<b>Driver Strength Selection</b> These two bits determine the drive strength of all I/O pins except for the following category of pins: LED pins, GPIO pins, INTRN, RSTN, and RXD3/REFCLK_0. 00 = 4 mA 01 = 8 mA. (Default when VDD_IO is 3.3V or 2.5V) 10 = 12 mA. (Default when VDD_IO is 1.8V) 11 = 16 mA.		
4 – 3	00	RW	Reserved		
2 – 0	111	RW	Reserved		

## 4.2.2 MAC ADDRESS REGISTERS

### 4.2.2.1 MAC Address Register 1 (0x010 – 0x011): MACAR1

This register contains the two MSBs of the MAC address for the controller function. This MAC address is used for sending PAUSE frames.

**TABLE 4-11: MAC ADDRESS REGISTER 1 (0X010 – 0X011): MACAR1**

Bit	Default	R/W	Description
15 – 0	0x0010	RW	<b>MACA[47:32]</b> Specifies MAC Address 1 for sending PAUSE frame.

### 4.2.2.2 MAC Address Register 2 (0x012 – 0x013): MACAR2

This register contains the MAC address for sending PAUSE frames.

**TABLE 4-12: MAC ADDRESS REGISTER 2 (0X012 – 0X013): MACAR2**

Bit	Default	R/W	Description
15 – 0	0xA1FF	RW	<b>MACA[31:16]</b> Specifies MAC Address 2 for sending PAUSE frame.

### 4.2.2.3 MAC Address Register 3 (0x014 – 0x015): MACAR3

This register contains the two LSBs of the MAC address for sending PAUSE frames.

**TABLE 4-13: MAC ADDRESS REGISTER 3 (0X014 – 0X015): MACAR3**

Bit	Default	R/W	Description
15 – 0	0xFFFF	RW	<b>MACA[15:0]</b> Specifies MAC Address 3 for sending PAUSE frame.

### 4.2.2.4 0x016 – 0x025: Reserved

## 4.2.3 INDIRECT ACCESS DATA REGISTERS

### 4.2.3.1 Indirect Access Data Register 1 (0x026 – 0x027): IADR1

This register is used to indirectly read or write the data in the MIB Counters. Refer to the MIB section that follows this section for detailed bit information.

**TABLE 4-14: INDIRECT ACCESS DATA REGISTER 1 (0X026 – 0X027): IADR1**

Bit	Default	R/W	Description
15 – 8	0x00	RO	Reserved
7	0	RO	<b>CPU Read Status</b> For statistics counter reads. 1 = Read is still in progress. 0 = Read has completed.
6 – 0	0x00	RO	Reserved

# KSZ8441HL/FHL

4.2.3.2 0x028 – 0x02B: Reserved

4.2.3.3 Indirect Access Data Register 4 (0x02C – 0x02D): IADR4

This register is used to indirectly read or write the data in the MIB Counters. Refer to the MIB section that follows this section for detailed bit information.

**TABLE 4-15: INDIRECT ACCESS DATA REGISTER 4 (0X02C – 0X02D): IADR4**

Bit	Default	R/W	Description
15 – 0	0x0000	RW	<b>Indirect Data [15:0]</b> Bit[15:0] of indirect data.

4.2.3.4 Indirect Access Data Register 5 (0x02E – 0x02F): IADR5

This register is used to indirectly read or write the data in the MIB Counters. Refer to the MIB section that follows this section for detailed bit information.

**TABLE 4-16: INDIRECT ACCESS DATA REGISTER 5 (0X02E – 0X02F): IADR5**

Bit	Default	R/W	Description
15 – 0	0x0000	RW	<b>Indirect Data [31:16]</b> Bit[31:16] of indirect data.

4.2.3.5 Indirect Access Control Register (0x030 – 0x031): IACR

This register is used to indirectly read or write the data in the MIB Counters. Writing to IACR triggers a command. Read or write access is determined by Register bit [12]. Refer to the MIB section that follows this section for detailed bit information.

**TABLE 4-17: INDIRECT ACCESS CONTROL REGISTER (0X030 – 0X031): IACR**

Bit	Default	R/W	Description
15 – 13	000	RW	Reserved
12	0	RW	<b>Read Enable</b> 1 = Read cycle is enabled (MIB Counter will be cleared after the read). 0 = No operation.
11 – 10	00	RW	<b>Table Select</b> 00 = Reserved. 01 = Reserved. 10 = Reserved. 11 = MIB counter selected.
9 – 0	0x000	RW	<b>Indirect Address [9:0]</b> Bit[9:0] of indirect address.

4.2.4 POWER MANAGEMENT CONTROL AND WAKE-UP EVENT STATUS

4.2.4.1 Power Management Control and Wake-Up Event Status (0x032 – 0x033): PMCTRL

This register controls the power management mode and provides wake-up event status.

**TABLE 4-18: POWER MANAGEMENT CONTROL AND WAKE-UP EVENT STATUS (0X032 – 0X033): PMCTRL**

Bit	Default	R/W	Description
15 – 6	0x000	RO	Reserved.
5	0	RW (W1C)	<b>Wake-Up Frame Detect Status</b> 1 = A wake-up frame has been detected at the host QMU (Write a “1” to clear). 0 = No Wake-Up frame has been detected.

**TABLE 4-18: POWER MANAGEMENT CONTROL AND WAKE-UP EVENT STATUS (0X032 – 0X033): PMCTRL (CONTINUED)**

Bit	Default	R/W	Description
4	0	RW (W1C)	<b>Magic Packet Detect Status</b> 1 = A Magic Packet has been detected at either port 1 (Write a “1” to clear). 0 = No Magic Packet has been detected.
3	0	RW (W1C)	<b>Link-Up Detect Status</b> 1 = A Link Up condition has been detected at either port 1 (Write a “1” to clear). 0 = No Link Up has been detected.
2	0	RW (W1C)	<b>Energy Detect Status</b> 1 = Energy is detected at either port 1 (Write a “1” to clear). 0 = No energy is detected. Note: This is not valid in fiber mode.
1 – 0	00	RW	<b>Power Management Mode</b> These two bits are used to control device power management mode. 00 = Normal Mode. 01 = Energy Detect Mode. 10 = Global Soft Power-Down Mode. (Does not reset QMU registers) 11 = Reserved.

#### 4.2.4.2 Power Management Event Enable Register (0x034 – 0x035): PMEE

This register contains the power management event enable control bits.

**TABLE 4-19: POWER MANAGEMENT EVENT ENABLE REGISTER (0X034 – 0X035): PMEE**

Bit	Default	R/W	Description
15 - 5	0x000	RW	Reserved
4	0	RW	<b>PME Polarity:</b> 1 = The PME pin is active-high. 0 = The PME pin is active-low.
3	0	RW	<b>PME Woken Up By Wake-Up Frame Enable</b> 1 = The PME pin will be asserted when a wake-up frame is detected. 0 = PME won't be asserted by the wake-up frame detection
2	0	RW	<b>PME Woken Up By Magic Packet Enable</b> 1 = The PME pin will be asserted when a magic packet is detected. 0 = PME won't be asserted by the magic packet detection
1	0	RW	<b>PME Woken Up By Link-Up Enable</b> 1 = The PME pin will be asserted when a link-up is detected at port 1. 0 = PME won't be asserted by the link-up detection
0	0	RW	<b>PME Woken Up By Energy Detect Enable</b> 1 = The PME pin will be asserted when energy on line is detected at port 1. 0 = PME won't be asserted by the energy detection.

#### 4.2.5 GO SLEEP TIME AND CLOCK TREE POWER-DOWN CONTROL REGISTERS

##### 4.2.5.1 Go Sleep Time Register (0x036 – 0x037): GST

This register contains the value which is used to control the minimum Go-Sleep time period when the device transitions from normal power state to low power state in energy detect mode.

**TABLE 4-20: GO SLEEP TIME REGISTER (0X036 – 0X037): GST**

Bit	Default	R/W	Description
15 – 8	0x00	RO	Reserved

# KSZ8441HL/FHL

**TABLE 4-20: GO SLEEP TIME REGISTER (0X036 – 0X037): GST (CONTINUED)**

Bit	Default	R/W	Description
7 – 0	0x8E	RW	<b>Go Sleep Time</b> This value is used to control the minimum period the no energy event has to be detected consecutively before the device enters the low power state during energy-detect mode. The unit is 20 ms. The default go sleep time is around 3.0 seconds.

## 4.2.5.2 Clock Tree Power-Down Control Register (0x038 – 0x039): CTPDC

This register contains the power-down control bits for all clocks.

**TABLE 4-21: CLOCK TREE POWER-DOWN CONTROL REGISTER (0X038 – 0X039): CTPDC**

Bit	Default	R/W	Description
15 – 5	0x000	RO	Reserved
4	0	RW	Reserved
3	0	RW	<b>Switch Clock Auto Shut Down Enable</b> 1 = When no packet transfer is detected on the MII interface of port 1 for longer than the time specified in bit[1:0] of current register, the device will shut down the switch clock automatically. The switch clock will be woken up automatically when the MII interface of any port becomes busy. 0 = Switch clock is always on.
2	0	RW	<b>CPU Clock Auto Shutdown Enable</b> 1 = When no packet transfer is detected both on host interface and on MII interface of port 1 for longer than the time specified in bit[1:0] of current register, the device will shut down CPU clock automatically. The CPU clock will be waked up automatically when host activity is detected or MII interface of any port becomes busy. 0 = CPU clock is always on.
1 – 0	00	RW	<b>Shutdown Wait Period</b> These two bits specify the time for device to monitor host/MII activity continuously before it could shut down switch or CPU clock. 00 = 5.3s. 01 = 1.6s. 10 = 1 ms. 11 = 3.2 μs.

## 4.2.5.3 0x03A – 0x04B: Reserved

## 4.2.6 PHY AND MII BASIC CONTROL REGISTERS

### 4.2.6.1 PHY 1 and MII Basic Control Register (0x04C – 0x04D): P1MBCR

This register contains media independent interface (MII) control bits for the switch port 1 function as defined in the IEEE 802.3 specification.

**TABLE 4-22: PHY 1 AND MII BASIC CONTROL REGISTER (0X04C – 0X04D): P1MBCR**

Bit	Default	R/W	Description	Bit is Same As
15	0	RO	Reserved	—
14	0	RW	<b>Far-End Loopback</b> 1 = Perform loopback as follows: Start: Host interface. Loopback: PMD/PMA of port 1's PHY End: Host interface. 0 = Normal operation.	Bit[14] in P1CR4



**TABLE 4-22: PHY 1 AND MII BASIC CONTROL REGISTER (0X04C – 0X04D): P1MBCR (CONTINUED)**

Bit	Default	R/W	Description	Bit is Same As
13	1	RW	<b>Force 100BASE-TX</b> 1 = Force 100 Mbps if auto-negotiation is disabled (bit [12]) 0 = Force 10 Mbps if auto-negotiation is disabled (bit [12])	Bit[6] in P1CR4
12	1	RW	<b>Auto-Negotiation Enable</b> 1 = Auto-negotiation enabled. 0 = Auto-negotiation disabled.	Bit[7] in P1CR4
11	0	RW	<b>Power-Down</b> 1 = Power-down. 0 = Normal operation.	Bit[11] in P1CR4
10	0	RO	<b>Isolate</b> Not supported.	—
9	0	RW/SC	<b>Restart Auto-Negotiation</b> 1 = Restart auto-negotiation. 0 = Normal operation.	Bit[13] in P1CR4
8	1	RW	<b>Force Full-Duplex</b> 1 = Force full-duplex. 0 = Force half-duplex. Applies only when auto-negotiation is disabled (bit [12]). It is always in half-duplex if auto-negotiation is enabled but failed.	Bit[5] in P1CR4
7	0	RO	<b>Collision test</b> Not supported.	—
6	0	RO	Reserved.	—
5	1	RW	<b>HP_MDIX</b> 1 = HP Auto-MDI-X mode. 0 = Microchip Auto-MDI-X mode.	Bit[15] in P1SR
4	0	RW	<b>Force MDI-X</b> 1 = Force MDI-X. 0 = Normal operation.	Bit[9] in P1CR4
3	0	RW	<b>Disable Auto-MDI-X</b> 1 = Disable Auto-MDI-X. 0 = Normal operation.	Bit[10] in P1CR4
2	0	RW	<b>Disable Far-End-Fault</b> 1 = Disable far-end-fault detection. 0 = Normal operation. For 100BASE-FX fiber mode operation.	Bit[12] in P1CR4
1	0	RW	<b>Disable Transmit</b> 1 = Disable transmit. 0 = Normal operation.	Bit[14] in P1CR4
0	0	RW	Reserved	—

# KSZ8441HL/FHL

## 4.2.6.2 PHY 1 and MII Basic Status Register (0x04E – 0x04F): P1MBSR

This register contains the media independent interface (MII) status bits for the switch port 1 function.

**TABLE 4-23: PHY 1 AND MII BASIC STATUS REGISTER (0X04E – 0X04F): P1MBSR**

Bit	Default	R/W	Description	Bit is Same As
15	0	RO	<b>T4 Capable</b> 1 = 100BASE-T4 capable. 0 = Not 100BASE-T4 capable.	—
14	1	RO	<b>100BASE-TX Full Capable</b> 1 = 100BASE-TX full-duplex capable. 0 = Not 100BASE-TX full-duplex capable.	—
13	1	RO	<b>100BASE-TX Half Capable</b> 1 = 100BASE-TX half-duplex capable. 0 = Not 100BASE-TX half-duplex capable.	—
12	1	RO	<b>10BASE-T Full Capable</b> 1 = 10BASE-T full-duplex capable. 0 = Not 10BASE-T full-duplex capable.	—
11	1	RO	<b>10BASE-T Half Capable</b> 1 = 10BASE-T half-duplex capable. 0 = Not 10BASE-T half-duplex capable.	—
10 – 7	0x0	RO	Reserved	—
6	0	RO	<b>Preamble Suppressed</b> Not supported.	—
5	0	RO	<b>Auto-Negotiation Complete</b> 1 = Auto-negotiation complete. 0 = Auto-negotiation not completed.	Bit[6] in P1SR
4	0	RO	<b>Far-End-Fault</b> 1 = Far-end-fault detected. 0 = No far-end-fault detected. For 100BASE-FX fiber mode operation.	Bit[8] in P1SR
3	1	RO	<b>Auto-Negotiation Capable</b> 1 = Auto-negotiation capable. 0 = Not auto-negotiation capable.	—
2	0	RO	<b>Link Status</b> 1 = Link is up. 0 = Link is down.	Bit[5] in P1SR
1	0	RO	<b>Jabber test</b> Not supported.	—
0	0	RO	<b>Extended Capable</b> 1 = Extended register capable. 0 = Not extended register capable.	—

## 4.2.6.3 PHY 1 PHYID Low Register (0x050 – 0x051): PHY1ILR

This register contains the PHY ID (low) for port 1.

**TABLE 4-24: PHY 1 PHYID LOW REGISTER (0X050 – 0X051): PHY1ILR**

Bit	Default	R/W	Description
15 – 0	0x1430	RO	<b>PHY 1 ID Low Word</b> Low order PHY 1 ID bits.

## 4.2.6.4 PHY 1 PHYID High Register (0x052 – 0x053): PHY1IHR

This register contains the PHY ID (high) for port 1.

**TABLE 4-25: PHY 1 PHYID HIGH REGISTER (0X052 – 0X053): PHY1IHR**

Bit	Default	R/W	Description
15 – 0	0x0022	RO	<b>PHY 1 ID High Word</b> High-order PHY 1 ID bits.

## 4.2.6.5 PHY 1 Auto-Negotiation Advertisement Register (0x054 – 0x055): P1ANAR

This register contains the auto-negotiation advertisement bits for port 1.

**TABLE 4-26: PHY 1 AUTO-NEGOTIATION ADVERTISEMENT REGISTER (0X054 – 0X055): P1ANAR**

Bit	Default	R/W	Description	Bit is Same As
15	0	RO	<b>Next page</b> Not supported.	—
14	0	RO	Reserved	—
13	0	RO	<b>Remote fault</b> Not supported.	—
12 – 11	00	RO	Reserved	—
10	1	RW	<b>Pause (flow control capability)</b> 1 = Advertise pause ability. 0 = Do not advertise pause capability.	Bit[4] in P1CR4
9	0	RW	Reserved	—
8	1	RW	<b>Advertise 100BASE-TX Full-Duplex</b> 1 = Advertise 100BASE-TX full-duplex capable. 0 = Do not advertise 100BASE-TX full-duplex capability.	Bit[3] in P1CR4
7	1	RW	<b>Advertise 100BASE-TX Half-Duplex</b> 1 = Advertise 100BASE-TX half-duplex capable. 0 = Do not advertise 100BASE-TX half-duplex capability.	Bit[2] in P1CR4
6	1	RW	<b>Advertise 10BASE-T Full-Duplex</b> 1 = Advertise 10BASE-T full-duplex capable. 0 = Do not advertise 10BASE-T full-duplex capability.	Bit[1] in P1CR4
5	1	RW	<b>Advertise 10BASE-T Half-Duplex</b> 1 = Advertise 10BASE-T half-duplex capable. 0 = Do not advertise 10BASE-T half-duplex capability.	Bit[0] in P1CR4
4 – 0	0x01	RO	<b>Selector Field</b> 802.3	—

## 4.2.6.6 PHY 1 Auto-Negotiation Link Partner Ability Register (0x056 – 0x057): P1ANLPR

This register contains the auto-negotiation link partner ability bits for the switch port 1 function.

**TABLE 4-27: PHY 1 AUTO-NEGOTIATION LINK PARTNER ABILITY REGISTER (0X056 – 0X057): P1ANLPR**

Bit	Default	R/W	Description	Bit is Same As
15	0	RO	<b>Next page</b> Not supported.	—
14	0	RO	<b>LP ACK</b> Not supported.	—
13	0	RO	<b>Remote fault</b> Not supported.	—

# KSZ8441HL/FHL

**TABLE 4-27: PHY 1 AUTO-NEGOTIATION LINK PARTNER ABILITY REGISTER (0X056 – 0X057): P1ANLPR (CONTINUED)**

Bit	Default	R/W	Description	Bit is Same As
12 - 11	00	RO	Reserved	—
10	0	RO	<b>Pause</b> Link partner pause capability.	Bit[4] in P1SR
9	0	RO	Reserved	—
8	0	RO	<b>Advertise 100BASE-TX Full-Duplex</b> Link partner 100BASE-TX full-duplex capability.	Bit[3] in P1SR
7	0	RO	<b>Advertise 100BASE-TX Half-Duplex</b> Link partner 100 half-duplex capability.	Bit[2] in P1SR
6	0	RO	<b>Advertise 10BASE-T Full-Duplex</b> Link partner 10BASE-T full-duplex capability.	Bit[1] in P1SR
5	0	RO	<b>Advertise 10BASE-T Half-Duplex</b> Link partner 10BASE-T half-duplex capability.	Bit[0] in P1SR
4 - 0	0x01	RO	Reserved	—

4.2.6.7 0x058 – 0x065: Reserved

4.2.6.8 PHY1 Special Control and Status Register (0x066 – 0x067): P1PHYCTRL

This register contains control and status information of PHY 1.

**TABLE 4-28: PHY1 SPECIAL CONTROL AND STATUS REGISTER (0X066 – 0X067): P1PHYCTRL**

Bit	Default	R/W	Description	Bit is Same As
15 - 6	0x000	RO	Reserved	—
5	0	RO	<b>Polarity Reverse</b> 1 = Polarity is reversed. 0 = Polarity is not reversed.	Bit[13] in P1SR
4	0	RO	<b>MDI-X Status</b> 0 = MDI 1 = MDI-X	Bit[7] in P1SR
3	0	RW	<b>Force Link</b> 1 = Force link pass. 0 = Normal operation.	Bit[11] in P1SCSLMD
2	1	RW	<b>Enable Energy Efficient Ethernet (EEE) on 10BASE-Te</b> 1 = Disable 10BASE-Te. 0 = Enable 10BASE-Te.	—
1	0	RW	<b>Remote (Near-End) Loopback</b> 1 = Perform remote loopback at port 1's PHY (RXP1/RXM1 -> TXP1/TXM1) 0 = Normal operation	Bit[9] in P1SCSLMD
0	0	RW	Reserved	—

4.2.6.9 0x068 – 0x06B: Reserved

## 4.2.7 PORT 1 CONTROL REGISTERS

### 4.2.7.1 Port 1 Control Register 1 (0x06C – 0x06D): P1CR1

This register contains control bits for Port 1 functions.

**TABLE 4-29: PORT 1 CONTROL REGISTER 1 (0X06C – 0X06D): P1CR1**

Bit	Default	R/W	Description
15	0	RO	Reserved
14 - 12	000	RW	<b>Port 1 LED Direct Control</b> These bits directly control the port 1 LED pins. 0xx = Normal LED function as set up via Reg. 0x00E – 0x00F, Bits[9:8]. 100 = Both port 1 LEDs off. 101 = Port 1 LED1 off, LED0 on. 110 = Port 1 LED1 on, LED0 off. 111 = Both port 1 LEDs on.
11 - 0	0x000	RW	Reserved

### 4.2.7.2 0x06E – 0x07B: Reserved

### 4.2.7.3 Port 1 PHY Special Control/Status, LinkMD (0x07C – 0x07D): P1SCSLMD

This register contains the LinkMD control and status information of PHY 1.

**TABLE 4-30: PORT 1 PHY SPECIAL CONTROL/STATUS, LINKMD (0X07C – 0X07D): P1SCSLMD**

Bit	Default	R/W	Description	Bit is Same As
15	0	RO	<b>CDT_10m_Short</b> 1 = Less than 10 meter short.	—
14 - 13	00	RO	<b>Cable Diagnostic Test Results</b> [00] = Normal condition. [01] = Open condition has been detected in cable. [10] = Short condition has been detected in cable. [11] = Cable diagnostic test has failed.	—
12	0	RW/SC	<b>Cable Diagnostic Test Enable</b> 1 = Cable diagnostic test is enabled. It is self-cleared after the test is done. 0 = Indicates that the cable diagnostic test has completed and the status information is valid for reading.	—
11	0	RW	<b>Force_Link</b> 1 = Force link pass. 0 = Normal operation.	Bit[3] in P1PHYCTRL
10	1	RW	Reserved	—
9	0	RW	<b>Remote (Near-End) Loopback</b> 1 = Perform remote loopback at port 1's PHY (RXP1/RXM1 -> TXP1/TXM1) 0 = Normal operation	Bit[1] in P1PHYCTRL
8 - 0	0x000	RO	<b>CDT_Fault_Count</b> Distance to the fault. It's approximately 0.4m*CDT_Fault_Count.	—

### 4.2.7.4 Port 1 Control Register 4 (0x07E – 0x07F): P1CR4

This register contains control bits for the switch port 1 function.

**TABLE 4-31: PORT 1 CONTROL REGISTER 4 (0X07E – 0X07F): P1CR4**

Bit	Default	R/W	Description	Bit is Same As
15	0	RW	Reserved	—

# KSZ8441HL/FHL

TABLE 4-31: PORT 1 CONTROL REGISTER 4 (0X07E – 0X07F): P1CR4 (CONTINUED)

Bit	Default	R/W	Description	Bit is Same As
14	0	RW	<b>Disable Transmit</b> 1 = Disable the port's transmitter. 0 = Normal operation.	Bit[1] in P1MBCR
13	0	RW/SC	<b>Restart Auto-Negotiation</b> 1 = Restart auto-negotiation. 0 = Normal operation.	Bit[9] in P1MBCR
12	0	RW	<b>Disable Far-End-Fault</b> 1 = Disable far-end-fault detection. 0 = Normal operation. For 100BASE-FX fiber mode operation.	Bit[2] in P1MBCR
11	0	RW	<b>Power Down</b> 1 = Power down. 0 = Normal operation. No change to registers setting.	Bit[11] in P1MBCR
10	0	RW	<b>Disable Auto-MDI/MDI-X</b> 1 = Disable Auto-MDI/MDI-X function. 0 = Enable Auto-MDI/MDI-X function.	Bit[3] in P1MBCR
9	0	RW	<b>Force MDI-X</b> 1 = If Auto-MDI/MDI-X is disabled, force PHY into MDI-X mode. 0 = Do not force PHY into MDI-X mode.	Bit[4] in P1MBCR
8	0	RW	<b>Far-End Loopback</b> 1 = Perform loopback, as indicated: Start: Host interface. Loopback: PMD/PMA of port 1's PHY. End: Host interface. 0 = Normal operation.	Bit[14] in P1MBCR
7	1	RW	<b>Auto-Negotiation Enable</b> 1 = Auto-negotiation is enabled. 0 = Disable auto-negotiation, speed, and duplex are decided by bits[6:5] of the same register.	Bit[12] in P1MBCR
6	1	RW	<b>Force Speed</b> 1 = Force 100BASE-TX if auto-negotiation is disabled (bit[7]). 0 = Force 10BASE-T if auto-negotiation is disabled (bit[7]).	Bit[13] in P1MBCR
5	1	RW	<b>Force Duplex</b> 1 = Force full-duplex if auto-negotiation is disabled. 0 = Force half-duplex if auto-negotiation is disabled. It is always in half-duplex if auto-negotiation is enabled but failed.	Bit[8] in P1MBCR
4	1	RW	<b>Advertised Flow Control Capability</b> 1 = Advertise flow control (pause) capability. 0 = Suppress flow control (pause) capability from transmission to link partner.	Bit[10] in P1ANAR
3	1	RW	<b>Advertised 100BASE-TX Full-Duplex Capability</b> 1 = Advertise 100BASE-TX full-duplex capability. 0 = Suppress 100BASE-TX full-duplex capability from transmission to link partner.	Bit [8] in P1ANAR
2	1	RW	<b>Advertised 100BASE-TX Half-Duplex Capability</b> 1 = Advertise 100BASE-TX half-duplex capability. 0 = Suppress 100BASE-TX half-duplex capability from transmission to link partner.	Bit[7] in P1ANAR

**TABLE 4-31: PORT 1 CONTROL REGISTER 4 (0X07E – 0X07F): P1CR4 (CONTINUED)**

Bit	Default	R/W	Description	Bit is Same As
1	1	RW	<b>Advertised 10BASE-T Full-Duplex Capability</b> 1 = Advertise 10BASE-T full-duplex capability. 0 = Suppress 10BASE-T full-duplex capability from transmission to link partner.	Bit[6] in P1ANAR
0	1	RW	<b>Advertised 10BASE-T Half-Duplex Capability</b> 1 = Advertise 10BASE-T half-duplex capability. 0 = Suppress 10BASE-T half-duplex capability from transmission to link partner.	Bit[5] in P1ANAR

#### 4.2.7.5 Port 1 Status Register (0x080 – 0x081): P1SR

This register contains status bits for port 1.

**TABLE 4-32: PORT 1 STATUS REGISTER (0X080 – 0X081): P1SR**

Bit	Default	R/W	Description	Bit is Same As
15	1	RW	<b>HP_Mdix</b> 1 = HP Auto-MDI-X mode. 0 = Microchip Auto-MDI-X mode.	Bit[5] in P1MBCR
14	0	RO	Reserved	—
13	0	RO	<b>Polarity Reverse</b> 1 = Polarity is reversed. 0 = Polarity is not reversed.	Bit[5] in P1PHYCTRL
12	0	RO	<b>Transmit Flow Control Enable</b> 1 = Transmit flow control feature is active. 0 = Transmit flow control feature is inactive.	—
11	0	RO	<b>Receive Flow Control Enable</b> 1 = Receive flow control feature is active. 0 = Receive flow control feature is inactive. <b>Transmit Flow Control Enable</b> 1 = Transmit flow control feature is active. 0 = Transmit flow control feature is inactive.	—
10	0	RO	<b>Operation Speed</b> 1 = Link speed is 100 Mbps. 0 = Link speed is 10 Mbps.	—
9	0	RO	<b>Operation Duplex</b> 1 = Link duplex is full. 0 = Link duplex is half.	—
8	0	RO	Reserved	—
7	0	RO	<b>MDI-X Status</b> 0 = MDI. 1 = MDI-X.	Bit[4] in P1PHYCTRL
6	0	RO	<b>Auto-Negotiation Done</b> 1 = Auto-negotiation done. 0 = Auto-negotiation not done.	Bit[5] in P1MBSR
5	0	RO	<b>Link Status</b> 1 = Link good. 0 = Link not good.	Bit[2] in P1MBSR
4	0	RO	<b>Partner Flow Control Capability</b> 1 = Link partner flow control (pause) capable. 0 = Link partner not flow control (pause) capable.	Bit[10] in P1ANLPR
3	0	RO	<b>Partner 100BASE-TX Full-Duplex Capability</b> 1 = Link partner 100BASE-TX full-duplex capable. 0 = Link partner not 100BASE-TX full-duplex capable.	Bit[8] in P1ANLPR

# KSZ8441HL/FHL

**TABLE 4-32: PORT 1 STATUS REGISTER (0X080 – 0X081): P1SR (CONTINUED)**

Bit	Default	R/W	Description	Bit is Same As
2	0	RO	<b>Partner 100BASE-TX Half-Duplex Capability</b> 1 = Link partner 100BASE-TX half-duplex capable. 0 = Link partner not 100BASE-TX half-duplex capable.	Bit[7] in P1ANLPR
1	0	RO	<b>Partner 10BASE-T Full-Duplex Capability</b> 1 = Link partner 10BASE-T full-duplex capable. 0 = Link partner not 10BASE-T full-duplex capable.	Bit[6] in P1ANLPR
0	0	RO	<b>Partner 10BASE-T Half-Duplex Capability</b> 1 = Link partner 10BASE-T half-duplex capable. 0 = Link partner not 10BASE-T half-duplex capable.	Bit[5] in P1ANLPR

4.2.7.6 0x082 – 0x0D5: Reserved

## 4.2.8 INPUT AND OUTPUT MULTIPLEX SELECTION REGISTER

### 4.2.8.1 Input and Output Multiplex Selection Register (0x0D6 – 0x0D7): IOMUXSEL

This register is used to select input/output pin functions of Pins 53, 54, and 55.

**TABLE 4-33: INPUT AND OUTPUT MULTIPLEX SELECTION REGISTER (0X0D6 – 0X0D7): IOMUXSEL**

Bit	Default	R/W	Description
15 - 12	0x0	RO	Reserved
11	1	RW	Reserved
10	1	RW	Reserved
9	1	RW	Reserved
8	1	RW	Reserved
7	1	RW	Reserved
6	1	RW	Reserved
5	1	RW	<b>Selection of EESK or GPIO3 on Pin 53</b> 1 = This pin is used for EESK (default), serial EEPROM clock. 0 = This pin is used for GPIO3.
4	1	RW	Reserved
3	1	RW	Reserved
2	1	RW	<b>Selection of EEDIO or GPIO4 on Pin 54</b> 1 = This pin is used for EEDIO (default), serial EEPROM data. 0 = This pin is used for GPIO4.
1	1	RW	<b>Selection of EECS or GPIO5 on Pin 55</b> 1 = This pin is used for EECS (default), serial EEPROM chip select. 0 = This pin is used for GPIO5.
0	1	RW	Reserved

## 4.2.9 CONFIGURATION STATUS AND SERIAL BUS MODE REGISTER

### 4.2.9.1 Configuration Status and Serial Bus Mode Register (0x0D8 – 0x0D9): CFGR

This register is used to select fiber mode, if desired.

**TABLE 4-34: CONFIGURATION STATUS AND SERIAL BUS MODE REGISTER (0X0D8 – 0X0D9): CFGR**

Bit	Default	R/W	Description
15 - 8	0x00	RO	Reserved
7	1	RW	Reserved



**TABLE 4-34: CONFIGURATION STATUS AND SERIAL BUS MODE REGISTER (0X0D8 – 0X0D9): CFGR (CONTINUED)**

Bit	Default	R/W	Description
6	1	RW	<b>Selection of Port 1 Mode of Operation</b> 1 = Select copper mode 0 = Select fiber mode (bypass MLT3 encoder/decoder, scrambler and descrambler). Fiber mode is available only for the KSZ8441FHL. When fiber mode is selected, bit [13] in DSP_CNTRL_6 (0x734 – 0x735) should be cleared.
5 - 4	11	RO	Reserved
3 - 0	0xE	RW	Reserved

4.2.9.2 0x0DA – 0x0DB: Reserved

#### 4.2.10 AUTO-NEGOTIATION NEXT PAGE REGISTERS

##### 4.2.10.1 Port 1 Auto-Negotiation Next Page Transmit Register (0x0DC – 0x0DD): P1ANPT

This register contains the port 1 auto-negotiation next page transmit related bits.

**TABLE 4-35: PORT 1 AUTO-NEGOTIATION NEXT PAGE TRANSMIT REGISTER (0X0DC – 0X0DD): P1ANPT**

Bit	Default	R/W	Description
15	0	RO	<b>Next Page</b> Next Page (NP) is used by the Next Page function to indicate whether or not this is the last Next Page to be transmitted. NP shall be set as follows: 1 = Additional Next Page(s) will follow. 0 = Last page.
14	0	RO	Reserved
13	1	RO	<b>Message Page</b> Message Page (MP) is used by the Next Page function to differentiate a Message Page from an Unformatted Page. MP shall be set as follows: 1 = Message Page. 0 = Unformatted Page.
12	0	RO	<b>Acknowledge 2</b> Acknowledge 2 (Ack2) is used by the Next Page function to indicate that a device has the ability to comply with the message. Ack2 shall be set as follows: 1 = Able to comply with message. 0 = Unable to comply with message.
11	0	RO	<b>Toggle</b> Toggle (T) is used by the arbitration function to ensure synchronization with the link partner during Next Page exchange. This bit shall always take the opposite value of the Toggle bit in the previously exchanged Link Codeword. The initial value of the Toggle bit in the first Next Page transmitted is the inverse of bit [11] in the base Link Codeword and, therefore, may assume a value of logic one or zero. The Toggle bit shall be set as follows: 1 = Previous value of the transmitted Link Codeword equal to logic zero. 0 = Previous value of the transmitted Link Codeword equal to logic one.
10 - 0	0x001	RO	<b>Message and Unformatted Code Field</b> Message/Unformatted code field bit[10:0]

# KSZ8441HL/FHL

## 4.2.10.2 Port 1 Auto-Negotiation Link Partner Received Next Page Register (0x0DE – 0x0DF): P1ALPRNP

This register contains the port 1 auto-negotiation link partner received next page related bits.

**TABLE 4-36: PORT 1 AUTO-NEGOTIATION LINK PARTNER RECEIVED NEXT PAGE REGISTER (0X0DE – 0X0DF): P1ALPRNP**

Bit	Default	R/W	Description
15	0	RO	<b>Next Page</b> Next Page (NP) is used by the Next Page function to indicate whether or not this is the last Next Page to be transmitted. NP shall be set as follows: 1 = Additional Next Page(s) will follow. 0 = Last page.
14	0	RO	<b>Acknowledge</b> Acknowledge (Ack) is used by the auto-negotiation function to indicate that a device has successfully received its Link Partner's Link Codeword. The Acknowledge bit is encoded in bit 14 regardless of the value of the Selector Field or Link Codeword encoding. If no Next Page information is to be sent, this bit shall be set to logic one in the Link Codeword after the reception of at least three consecutive and consistent FLP Bursts (ignoring the Acknowledge bit value).
13	0	RO	<b>Message Page</b> Message Page (MP) is used by the Next Page function to differentiate a Message Page from an Unformatted Page. MP shall be set as follows: 1 = Message Page. 0 = Unformatted Page.
12	0	RO	<b>Acknowledge 2</b> Acknowledge 2 (Ack2) is used by the Next Page function to indicate that a device has the ability to comply with the message. Ack2 shall be set as follows: 1 = Able to comply with message. 0 = Unable to comply with message.
11	0	RO	<b>Toggle</b> Toggle (T) is used by the arbitration function to ensure synchronization with the link partner during Next Page exchange. This bit shall always take the opposite value of the Toggle bit in the previously exchanged Link Codeword. The initial value of the Toggle bit in the first Next Page transmitted is the inverse of bit [11] in the base Link Codeword and, therefore, may assume a value of logic one or zero. The Toggle bit shall be set as follows: 1 = Previous value of the transmitted Link Codeword equal to logic zero. 0 = Previous value of the transmitted Link Codeword equal to logic one.
10 - 0	0x000	RO	<b>Message and Unformatted Code Field</b> Message/Unformatted code field bit[10:0]

## 4.2.11 EEE AND LINK PARTNER ADVERTISEMENT REGISTERS

### 4.2.11.1 Port 1 EEE and Link Partner Advertisement Register (0x0E0 – 0x0E1): P1EEEE

This register contains the port 1 EEE advertisement and link partner advertisement information. Note that EEE is not supported in fiber mode.

**TABLE 4-37: PORT 1 EEE AND LINK PARTNER ADVERTISEMENT REGISTER (0X0E0 – 0X0E1): P1EEEE**

Bit	Default	R/W	Description
15	0	RO	Reserved

**TABLE 4-37: PORT 1 EEE AND LINK PARTNER ADVERTISEMENT REGISTER (0X0E0 – 0X0E1): P1EEEA (CONTINUED)**

Bit	Default	R/W	Description
14	0	RO	<b>10GBASE-KR EEE</b> 1 = Link Partner EEE is supported for 10GBASE-KR. 0 = Link Partner EEE is not supported for 10GBASE-KR.
13	0	RO	<b>10GBASE-KX4 EEE</b> 1 = Link Partner EEE is supported for 10GBASE-KX4. 0 = Link Partner EEE is not supported for 10GBASE-KX4.
12	0	RO	<b>1000BASE-KX EEE</b> 1 = Link Partner EEE is supported for 1000BASE-KX. 0 = Link Partner EEE is not supported for 1000BASE-KX.
11	0	RO	<b>10GBASE-T EEE</b> 1 = Link Partner EEE is supported for 10GBASE-T. 0 = Link Partner EEE is not supported for 10GBASE-T.
10	0	RO	<b>1000BASE-T EEE</b> 1 = Link Partner EEE is supported for 1000BASE-T. 0 = Link Partner EEE is not supported for 1000BASE-T.
9	0	RO	<b>100BASE-TX EEE</b> 1 = Link Partner EEE is supported for 100BASE-TX. 0 = Link Partner EEE is not supported for 100BASE-TX.
8 - 7	00	RO	Reserved
6	0	RO	<b>10GBASE-KR EEE</b> 1 = Port 1 EEE is supported for 10GBASE-KR. 0 = Port 1 EEE is not supported for 10GBASE-KR.
5	0	RO	<b>10GBASE-KX4 EEE</b> 1 = Port 1 EEE is supported for 10GBASE-KX4. 0 = Port 1 EEE is not supported for 10GBASE-KX4.
4	0	RO	<b>1000BASE-KX EEE</b> 1 = Port 1 EEE is supported for 1000BASE-KX. 0 = Port 1 EEE is not supported for 1000BASE-KX.
3	0	RO	<b>10GBASE-T EEE</b> 1 = Port 1 EEE is supported for 10GBASE-T. 0 = Port 1 EEE is not supported for 10GBASE-T.
2	0	RO	<b>1000BASE-T EEE</b> 1 = Port 1 EEE is supported for 1000BASE-T. 0 = Port 1 EEE is not supported for 1000BASE-T.
1	1	RW	<b>100BASE-TX EEE</b> 1 = Port 1 EEE is supported for 100BASE-TX. 0 = Port 1 EEE is not supported for 100BASE-TX. To disable EEE capability, clear the Next Page Enable bit in the PCSEEEC register.
0	0	RO	Reserved

#### 4.2.11.2 Port 1 EEE Wake Error Count Register (0x0E2 – 0x0E3): P1EEEWEC

This register contains the port 1 EEE wake error count information. Note that EEE is not supported in Fiber mode.

**TABLE 4-38: PORT 1 EEE WAKE ERROR COUNT REGISTER (0X0E2 – 0X0E3): P1EEEWEC**

Bit	Default	R/W	Description
15 - 0	0x0000	RW	<b>Port 1 EEE Wake Error Count</b> This counter is incremented by each transition of lpi_wake_timer_done from FALSE to TRUE. It means the wakeup time is longer than 20.5 $\mu$ s. The value will be held at all ones in the case of overflow and will be cleared to zero after this register is read.

# KSZ8441HL/FHL

## 4.2.11.3 Port 1 EEE Control/Status and Auto-Negotiation Expansion Register (0x0E4 – 0x0E5): P1EEEECS

This register contains the port 1 EEE control/status and auto-negotiation expansion information. Note that EEE is not supported in Fiber mode.

**TABLE 4-39: PORT 1 EEE CONTROL/STATUS AND AUTO-NEGOTIATION EXPANSION REGISTER (0X0E4 – 0X0E5): P1EEEECS**

Bit	Default	R/W	Description
15	1	RW	Reserved
14	0	RO	<b>Hardware 100BASE-TX EEE Enable Status</b> 1 = 100BASE-TX EEE is enabled by hardware-based NP exchange. 0 = 100BASE-TX EEE is disabled.
13	0	RO/LH (Latching High)	<b>TX LPI Received</b> 1 = Indicates that the transmit PCS has received low power idle (LPI) signaling one or more times since the register was last read. 0 = Indicates that the PCS has not received low power idle (LPI) signaling. The status will be latched high and stay that way until cleared. To clear this status bit, a “1” needs to be written to this register bit.
12	0	RO	<b>TX LPI Indication</b> 1 = Indicates that the transmit PCS is currently receiving low power idle (LPI) signals. 0 = Indicates that the PCS is not currently receiving low power idle (LPI) signals. This bit will dynamically indicate the presence of the TX LPI signal.
11	0	RO/LH (Latching High)	<b>RX LPI Received</b> 1 = Indicates that the receive PCS has received low power idle (LPI) signaling one or more times since the register was last read. 0 = Indicates that the PCS has not received low power idle (LPI) signaling. The status will be latched high and stay that way until cleared. To clear this status bit, a “1” needs to be written to this register bit.
10	0	RO	<b>RX LPI Indication</b> 1 = Indicates that the receive PCS is currently receiving low power idle (LPI) signals. 0 = Indicates that the PCS is not currently receiving low power idle (LPI) signals. This bit will dynamically indicate the presence of the RX LPI signal.
9 - 8	00	RW	Reserved
7	0	RO	Reserved
6	1	RO	<b>Received Next Page Location Able</b> 1 = Received Next Page storage location is specified by bit[6:5]. 0 = Received Next Page storage location is not specified by bit[6:5].
5	1	RO	<b>Received Next Page Storage Location</b> 1 = Link partner Next Pages are stored in P1ALPRNP (Reg. 0x0DE – 0x0DF). 0 = Link partner Next Pages are stored in P1ANLPR (Reg. 0x056 – 0x057).
4	0	RO/LH (Latching High)	<b>Parallel Detection Fault</b> 1 = A fault has been detected via the parallel detection function. 0 = A fault has not been detected via the parallel detection function. This bit is cleared after read.
3	0	RO	<b>Link Partner Next Page Able</b> 1 = Link partner is Next Page abled. 0 = Link partner is not Next Page abled.

**TABLE 4-39: PORT 1 EEE CONTROL/STATUS AND AUTO-NEGOTIATION EXPANSION REGISTER (0X0E4 – 0X0E5): P1EEECs (CONTINUED)**

Bit	Default	R/W	Description
2	0	RO	<b>Next Page Able</b> 1 = Local device is Next Page abled. 0 = Local device is not Next Page abled.
1	0	RO/LH (Latching High)	<b>Page Received</b> 1 = A New Page has been received. 0 = A New Page has not been received.
0	0	RO	<b>Link Partner Auto-Negotiation Able</b> 1 = Link partner is auto-negotiation abled. 0 = Link partner is not auto-negotiation abled.

## 4.2.12 PORT 1 LPI RECOVERY TIME COUNTER REGISTER

### 4.2.12.1 Port 1 LPI Recovery Time Counter Register (0x0E6): P1LPIRTC

This register contains the port 1 LPI recovery time counter information.

**TABLE 4-40: PORT 1 LPI RECOVERY TIME COUNTER REGISTER (0X0E6): P1LPIRTC**

Bit	Default	R/W	Description
7 - 0	0x27 (25 $\mu$ s)	RW	<b>Port 1 LPI Recovery Time Counter</b> This register specifies the time that the MAC device has to wait before it can start to send out packets. This value should be the maximum of the LPI recovery time between local device and remote device. Each count is 640 ns.

## 4.2.13 BUFFER LOAD-TO-LPI CONTROL 1 REGISTER

### 4.2.13.1 Buffer Load to LPI Control 1 Register (0x0E7): BL2LPIC1

This register contains the buffer load to LPI Control 1 information.

**TABLE 4-41: BUFFER LOAD TO LPI CONTROL 1 REGISTER (0X0E7): BL2LPIC1**

Bit	Default	R/W	Description
7	0	RW	<b>LPI Terminated by Input Traffic Enable</b> 1 = LPI request will be stopped if input traffic is detected. 0 = LPI request won't be stopped by input traffic.
6	0	RO	Reserved
5 - 0	0x08	RW	<b>Buffer Load Threshold for Source Port LPI Termination</b> This value defines the maximum buffer usage allowed for a single port before it starts to trigger the LPI termination for the specific source port. (512 bytes per unit)

### 4.2.13.2 0x0E8 – 0x0F1: Reserved

## 4.2.14 PCS EEE CONTROL REGISTER

### 4.2.14.1 PCS EEE Control Register (0x0F2 - 0x0F3): PCSEEEEC

This register contains the PCS EEE control information.

**TABLE 4-42: PCS EEE CONTROL REGISTER (0X0F3): PCSEEEEC**

Bit	Default	R/W	Description
15 - 14	00	RW	Reserved
13 - 10	0x0	RO	Reserved
9	1	RW	Reserved

# KSZ8441HL/FHL

**TABLE 4-42: PCS EEE CONTROL REGISTER (0X0F3): PCSEEEC (CONTINUED)**

Bit	Default	R/W	Description
8	1	RW	<b>Next Page Enable</b> 1 = Enable next page exchange during auto-negotiation. 0 = Skip next page exchange during auto-negotiation. Auto-negotiation uses next page to negotiate EEE. To disable EEE auto-negotiation on port 1, clear this bit to zero. Restarting auto-negotiation may then be required.
7 - 0	0x27	RW	Reserved

## 4.2.15 EMPTY TXQ-TO-LPI WAIT TIME CONTROL REGISTER

### 4.2.15.1 Empty TXQ to LPI Wait Time Control Register (0x0F4 – 0x0F5): ETLWTC

This register contains the empty TXQ to LPI wait time control information.

**TABLE 4-43: EMPTY TXQ TO LPI WAIT TIME CONTROL REGISTER (0X0F4 – 0X0F5): ETLWTC**

Bit	Default	R/W	Description
15 - 0	0x03E8	RW	<b>Empty TXQ to LPI Wait Time Control</b> This register specifies the time that the LPI request will be generated after a TXQ has been empty exceeds this configured time. This is only valid when EEE 100BASE-TX is enabled. This setting will apply to Port 1 and the Host Port. The unit is 1.3 ms. The default value is 1.3 seconds (range from 1.3 ms to 86 seconds)

## 4.2.16 BUFFER LOAD-TO-LPI CONTROL 2 REGISTER

### 4.2.16.1 Buffer Load to LPI Control 2 Register (0x0F6 – 0x0F7): BL2LPIC2

This register contains the buffer load to LPI control 2 information.

**TABLE 4-44: BUFFER LOAD TO LPI CONTROL 2 REGISTER (0X0F6 – 0X0F7): BL2LPIC2**

Bit	Default	R/W	Description
15 - 8	0x01	RO	Reserved
7 - 0	0x40	RW	<b>Buffer Load Threshold for All Ports LPI Termination</b> This value defines the maximum buffer usage allowed for a single port before it starts to trigger the LPI termination for every port. (128 bytes per unit)

4.2.16.2 0x0F8 – 0x0FF: Reserved

## 4.2.17 INTERNAL I/O REGISTER SPACE MAPPING FOR INTERRUPTS, BIU, AND GLOBAL RESET (0X100 – 0X1FF)

4.2.17.1 0x100 – 0x107: Reserved

### 4.2.17.2 Chip Configuration Register (0x108 – 0x109): CCR

This register indicates the chip configuration mode based on strapping and bonding options.

**TABLE 4-45: CHIP CONFIGURATION REGISTER (0X108 – 0X109): CCR**

Bit	Default	R/W	Description
15 - 11	—	RO	Reserved
10	—	RO	<b>Bus Endian Mode</b> The LEBE pin value is latched into this bit during power-up/reset. 0 = Bus in Big Endian mode 1 = Bus in Little Endian mode

**TABLE 4-45: CHIP CONFIGURATION REGISTER (0X108 – 0X109): CCR (CONTINUED)**

Bit	Default	R/W	Description
9	—	RO	<b>EEPROM Presence</b> The PME/EESEL pin value is latched into this bit during power-up/reset. 0 = No external EEPROM 1 = Use external EEPROM
8	0	RO	Reserved
7	—	RO	<b>8-Bit Data Bus Width</b> This bit value is loaded from P1LED0/H816 (pin 60) to indicate the status of 8-bit data bus mode. 0 = Not in 8-bit bus mode operation 1 = In 8-bit bus mode operation
6	—	RO	<b>16-Bit Data Bus Width</b> This bit value is loaded from P1LED0/H816 (pin 60) to indicate the status of 16-bit data bus mode. 0 = Not in 16-bit bus mode operation 1 = In 16-bit bus mode operation
5	0	RO	Reserved
4	1	RO	<b>Shared Data Bus Mode for Data and Address</b> 0 = Not valid 1 = Data and address bus are shared.
3 - 0	0x2	RO	Reserved

4.2.17.3 0x10A – 0x10F: Reserved

4.2.17.4 Host MAC Address Registers: MARL, MARM, and MARH

These host MAC address registers are loaded starting at word location 0x1 of the EEPROM upon hardware reset. The software driver can read or write these registers values, but it will not modify the original host MAC address values in the EEPROM. These six bytes of host MAC address in external EEPROM are loaded to these three registers as mapped below:

- MARL[15:0] = EEPROM 0x1 (MAC Byte 2 and 1)
- MARM[15:0] = EEPROM 0x2 (MAC Byte 4 and 3)
- MARH[15:0] = EEPROM 0x3 (MAC Byte 6 and 5)

The host MAC address is used to define the individual destination address that the KSZ8441 responds to when receiving frames. Network addresses are generally expressed in the form of 01:23:45:67:89:AB, where the bytes are received from left to right, and the bits within each byte are received from right to left (LSB to MSB). For example, the actual transmitted and received bits are on the order of 10000000 11000100 10100010 11100110 10010001 11010101. These three registers value for host MAC address 01:23:45:67:89:AB will be held as below:

- MARL[15:0] = 0x89AB
- MARM[15:0] = 0x4567
- MARH[15:0] = 0x0123

**TABLE 4-46: HOST MAC ADDRESS REGISTER LOW (0X110 – 0X111): MARL**

Bit	Default	R/W	Description
15 - 0	—	RW	<b>MARL MAC Address Low</b> The least significant word of the MAC Address.

**TABLE 4-47: HOST MAC ADDRESS REGISTER MIDDLE (0X112 – 0X113): MARM**

Bit	Default	R/W	Description
15 - 0	—	RW	<b>MARM MAC Address Middle</b> The middle word of the MAC Address.

# KSZ8441HL/FHL

**TABLE 4-48: HOST MAC ADDRESS REGISTER HIGH (0X114 – 0X115): MARH**

Bit	Default	R/W	Description
15 - 0	—	RW	<b>MARH MAC Address High</b> The most significant word of the MAC Address.

4.2.17.5 0x116 – 0x121: Reserved

4.2.17.6 EEPROM Control Register (0x122 – 0x123): EEP CR

To support an external EEPROM, the PME/EEPROM pin should be pulled-up to high; otherwise, it should be pulled low. If an external EEPROM is not used, the software should program the host MAC address. If an EEPROM is used in the design, the chip host MAC address can be loaded from the EEPROM immediately after reset. The KSZ8441 allows the software to access (read or write) the EEPROM directly; that is, the EEPROM access timing can be fully controlled by the software if the EEPROM software access bit is set.

**TABLE 4-49: EEPROM CONTROL REGISTER (0X122 – 0X123): EEP CR**

Bit	Default	R/W	Description
15 - 6	—	RO	Reserved
5	0	WO	<b>EESWA EEPROM Software Read or Write Access</b> 0 = S/W read enable to access EEPROM when software access enabled (bit[4] = “1”) 1 = S/W write enable to access EEPROM when software access enabled (bit[4] = “1”)
4	0	RW	<b>EESA EEPROM Software Access</b> 1 = Enable software to access EEPROM through bits[3:0]. 0 = Disable software to access EEPROM.
3	—	RO	<b>EESB EEPROM Status Bit</b> Data Receive from EEPROM. This bit directly reads the EEDIO pin.
2	0	RW	<b>EECB_EEPROM_WR_DATA</b> Write Data to EEPROM. This bit directly controls the device's EEDIO pin.
1	0	RW	<b>EECB_EEPROM_Clock</b> Serial EEPROM Clock. This bit directly controls the device's EESK pin.
0	0	RW	<b>EECB_EEPROM_CS</b> Chip Select for the EEPROM. This bit directly controls the device's EECS pin.

4.2.17.7 Memory BIST Info Register (0x124 – 0x125): MBIR

This register indicates the built-in self-test results for both TX and RX memories after power-up/reset. The device should be reset after the BIST procedure to ensure proper subsequent operation.

**TABLE 4-50: MEMORY BIST INFO REGISTER (0X124 – 0X125): MBIR**

Bit	Default	R/W	Description
15	0	RO	<b>Memory BIST Done</b> 0 = BIST In progress 1 = BIST Done
14 - 13	00	RO	Reserved
12	—	RO	<b>TXMBF TX Memory BIST Completed</b> 0 = TX Memory built-in self-test has not completed. 1 = TX Memory built-in self-test has completed.
11	—	RO	<b>TXMBFA TX Memory BIST Failed</b> 0 = TX Memory built-in self-test has completed without failure. 1 = TX Memory built-in self-test has completed with failure.
10 - 8	—	RO	<b>TXMBFC TX Memory BIST Fail Count</b> 0 = TX Memory built-in self-test completed with no count failure. 1 = TX Memory built-in self-test encountered a failed count condition.



**TABLE 4-50: MEMORY BIST INFO REGISTER (0X124 – 0X125): MBIR (CONTINUED)**

Bit	Default	R/W	Description
7 - 5	—	RO	Reserved
4	—	RO	<b>RXMBF RX Memory BIST Completed</b> 0 = Completion has not occurred for the RX Memory built-in self-test. 1 = Indicates completion of the RX Memory built-in self-test.
3	—	RO	<b>RXMBFA RX Memory BIST Failed</b> 0 = No failure with the RX Memory built-in self-test. 1 = Indicates the RX Memory built-in self-test has failed.
2 - 0	—	RO	<b>RXMBFC RX Memory BIST Test Fail Count</b> 0 = No count failure for the RX Memory BIST. 1 = Indicates the RX Memory built-in self-test failed count.

#### 4.2.17.8 Global Reset Register (0x126 – 0x127): GRR

This register controls the global and PTP reset functions with information programmed by the CPU.

**TABLE 4-51: GLOBAL RESET REGISTER (0X126 – 0X127): GRR**

Bit	Default	R/W	Description
15 - 4	0x000	RO	Reserved
3	0	RW	<b>Memory BIST Start</b> 1 = Setting this bit will start the Memory BIST. 0 = Setting this bit will stop the Memory BIST.
2	0	RW	<b>PTP Module Soft Reset</b> 1 = Setting this bit resets the 1588/PTP blocks including the time stamp input units, the trigger output units and the PTP clock. 0 = Software reset is inactive.
1	0	RW	<b>QMU Module Soft Reset</b> 1 = Software reset is active to clear both the TXQ and RXQ memories. 0 = QMU reset is inactive. QMU software reset will flush out all TX/RX packet data inside the TXQ and RXQ memories and reset all the QMU registers to their default value.
0	0	RW	<b>Global Soft Reset</b> 1 = Software reset is active. 0 = Software reset is inactive. Global software reset will reset all registers to their default value. The strap-in values are not affected. This bit is not self-clearing. After writing a "1" to this bit, wait for 10 ms to elapse then write a "0" for normal operation.

#### 4.2.17.9 0x128 – 0x129: Reserved

#### 4.2.17.10 Wake-Up Frame Control Register (0x12A – 0x12B): WFCR

This register holds control information programmed by the CPU to control the Wake-Up frame function.

**TABLE 4-52: WAKE-UP FRAME CONTROL REGISTER (0X12A – 0X12B): WFCR**

Bit	Default	R/W	Description
15 - 8	0x00	RO	Reserved
7	0	RW	<b>MPRXE</b> Magic Packet RX Enable When set, it enables the Magic Packet pattern detection. When reset, the Magic Packet pattern detection is disabled.
6 - 4	000	RO	Reserved

# KSZ8441HL/FHL

**TABLE 4-52: WAKE-UP FRAME CONTROL REGISTER (0X12A – 0X12B): WFCR (CONTINUED)**

Bit	Default	R/W	Description
3	0	RW	<b>WF3E</b> Wake-Up Frame 3 Enable When set, it enables the Wake-Up frame 3 pattern detection. When reset, the Wake-Up frame 3 pattern detection is disabled.
2	0	RW	<b>WF2E</b> Wake-Up Frame 2 Enable When set, it enables the Wake-Up frame 2 pattern detection. When reset, the Wake-Up frame 2 pattern detection is disabled.
1	0	RW	<b>WF1E</b> Wake-Up Frame 1 Enable When set, it enables the Wake-Up frame 1 pattern detection. When reset, the Wake-Up frame 1 pattern detection is disabled.
0	0	RW	<b>WF0E</b> Wake-Up Frame 0 Enable When set, it enables the Wake-Up frame 0 pattern detection. When reset, the Wake-Up frame 0 pattern detection is disabled.

4.2.17.11 0x12C – 0x12F: Reserved

4.2.17.12 Wake-Up Frame 0 CRC0 Register (0x130 – 0x131): WF0CRC0

This register contains the expected CRC values of the Wake-Up frame 0 pattern.

The value of the CRC calculated is based on the IEEE 802.3 Ethernet standard; it is taken over the bytes specified in the Wake-Up byte mask registers.

**TABLE 4-53: WAKE-UP FRAME 0 CRC0 REGISTER (0X130 – 0X131): WF0CRC0**

Bit	Default	R/W	Description
15 - 0	0x0000	RW	<b>WF0CRC0</b> Wake-Up Frame 0 CRC (lower 16 bits) The expected CRC value of a Wake-Up frame 0 pattern.

4.2.17.13 Wake-Up Frame 0 CRC1 Register (0x132 – 0x133): WF0CRC1

This register contains the expected CRC values of the Wake-Up frame 0 pattern.

The value of the CRC calculated is based on the IEEE 802.3 Ethernet standard; it is taken over the bytes specified in the Wake-Up byte mask registers.

**TABLE 4-54: WAKE-UP FRAME 0 CRC1 REGISTER (0X132 – 0X133): WF0CRC1**

Bit	Default	R/W	Description
15 - 0	0x0000	RW	<b>WF0CRC1</b> Wake-Up Frame 0 CRC (upper 16 bits). The expected CRC value of a Wake-Up frame 0 pattern.

4.2.17.14 Wake-Up Frame 0 Byte Mask 0 Register (0x134 – 0x135): WF0BM0

This register contains the first 16 bytes mask values of the Wake-Up frame 0 pattern. Setting bit [0] selects the first byte of the Wake-Up frame 0. Setting bit [15] selects the 16th byte of the Wake-Up frame 0.

**TABLE 4-55: WAKE-UP FRAME 0 BYTE MASK 0 REGISTER (0X134 – 0X135): WF0BM0**

Bit	Default	R/W	Description
15 - 0	0x0000	RW	<b>WF0BM0</b> Wake-Up Frame 0 Byte Mask 0 The first 16 byte mask of a Wake-Up frame 0 pattern.

## 4.2.17.15 Wake-Up Frame 0 Byte Mask 1 Register (0x136 – 0x137): WF0BM1

This register contains the next 16 bytes mask values of the Wake-Up frame 0 pattern. Setting bit [0] selects the 17th byte of the Wake-Up frame 0. Setting bit [15] selects the 32nd byte of the Wake-Up frame 0.

**TABLE 4-56: WAKE-UP FRAME 0 BYTE MASK 1 REGISTER (0X136 – 0X137): WF0BM1**

Bit	Default	R/W	Description
15 - 0	0x0000	RW	<b>WF0BM1</b> Wake-Up Frame 0 Byte Mask 1. The next 16 byte mask covering bytes 17 to 32 of a Wake-Up frame 0 pattern.

## 4.2.17.16 Wake-Up Frame 0 Byte Mask 2 Register (0x138 – 0x139): WF0BM2

This register contains the next 16 bytes mask values of the Wake-Up frame 0 pattern. Setting bit [0] selects the 33rd byte of the Wake-Up frame 0. Setting bit [15] selects the 48th byte of the Wake-Up frame 0.

**TABLE 4-57: WAKE-UP FRAME 0 BYTE MASK 2 REGISTER (0X138 – 0X139): WF0BM2**

Bit	Default	R/W	Description
15 - 0	0x0000	RW	<b>WF0BM2</b> Wake-Up Frame 0 Byte Mask 2. The next 16 byte mask covering bytes 33 to 48 of a wake-up frame 0 pattern.

## 4.2.17.17 Wake-Up Frame 0 Byte Mask 3 Register (0x13A – 0x13B): WF0BM3

This register contains the last 16 bytes mask values of the Wake-Up frame 0 pattern. Setting bit [0] selects the 49th byte of the Wake-Up frame 0. Setting bit [15] selects the 64th byte of the Wake-Up frame 0.

**TABLE 4-58: WAKE-UP FRAME 0 BYTE MASK 3 REGISTER (0X13A – 0X13B): WF0BM3**

Bit	Default	R/W	Description
15 - 0	0x0000	RW	<b>WF0BM3</b> Wake-Up Frame 0 Byte Mask 3. The last 16 byte mask covering bytes 49 to 64 of a wake-up frame 0 pattern.

## 4.2.17.18 0x13C – 0x13F: Reserved

## 4.2.17.19 Wake-Up Frame 1 CRC0 Register (0x140 – 0x141): WF1CRC0

This register contains the expected CRC values of the Wake-Up frame 1 pattern.

The value of the CRC calculated is based on the IEEE 802.3 Ethernet standard; it is taken over the bytes specified in the Wake-Up byte mask registers.

**TABLE 4-59: WAKE-UP FRAME 1 CRC0 REGISTER (0X140 – 0X141): WF1CRC0**

Bit	Default	R/W	Description
15 - 0	0x0000	RW	<b>WF1CRC0</b> Wake-Up Frame 1 CRC (lower 16 bits) The expected CRC value of a Wake-Up frame 1 pattern.

# KSZ8441HL/FHL

## 4.2.17.20 Wake-Up Frame 1 CRC1 Register (0x142 – 0x143): WF1CRC1

This register contains the expected CRC values of the Wake-Up frame 1 pattern.

The value of the CRC calculated is based on the IEEE 802.3 Ethernet standard; it is taken over the bytes specified in the Wake-Up byte mask registers.

**TABLE 4-60: WAKE-UP FRAME 0 CRC1 REGISTER (0X142 – 0X143): WF1CRC1**

Bit	Default	R/W	Description
15 - 0	0x0000	RW	<b>WF1CRC1</b> Wake-Up Frame 1 CRC (upper 16 bits). The expected CRC value of a Wake-Up frame 1 pattern.

## 4.2.17.21 Wake-Up Frame 1 Byte Mask 0 Register (0x144 – 0x145): WF1BM0

This register contains the first 16 bytes mask values of the Wake-Up frame 1 pattern. Setting bit [0] selects the first byte of the Wake-Up frame 1. Setting bit [15] selects the 16th byte of the Wake-Up frame 1.

**TABLE 4-61: WAKE-UP FRAME 1 BYTE MASK 0 REGISTER (0X144 – 0X145): WF1BM0**

Bit	Default	R/W	Description
15 - 0	0x0000	RW	<b>WF1BM0</b> Wake-Up Frame 1 Byte Mask 0 The first 16 byte mask of a Wake-Up frame 1 pattern.

## 4.2.17.22 Wake-Up Frame 1 Byte Mask 1 Register (0x146 – 0x147): WF1BM1

This register contains the next 16 bytes mask values of the Wake-Up frame 1 pattern. Setting bit [0] selects the 17th byte of the Wake-Up frame 1. Setting bit [15] selects the 32nd byte of the Wake-Up frame 1.

**TABLE 4-62: WAKE-UP FRAME 1 BYTE MASK 1 REGISTER (0X146 – 0X147): WF1BM1**

Bit	Default	R/W	Description
15 - 0	0x0000	RW	<b>WF1BM1</b> Wake-Up Frame 1 Byte Mask 1. The next 16 byte mask covering bytes 17 to 32 of a Wake-Up frame 1 pattern.

## 4.2.17.23 Wake-Up Frame 1 Byte Mask 2 Register (0x148 – 0x149): WF1BM2

This register contains the next 16 bytes mask values of the Wake-Up frame 1 pattern. Setting bit [0] selects the 33rd byte of the Wake-Up frame 1. Setting bit [15] selects the 48th byte of the Wake-Up frame 1.

**TABLE 4-63: WAKE-UP FRAME 1 BYTE MASK 2 REGISTER (0X148 – 0X149): WF1BM2**

Bit	Default	R/W	Description
15 - 0	0x0000	RW	<b>WF1BM2</b> Wake-Up Frame 1 Byte Mask 2. The next 16 byte mask covering bytes 33 to 48 of a wake-up frame 1 pattern.

## 4.2.17.24 Wake-Up Frame 1 Byte Mask 3 Register (0x14A – 0x14B): WF1BM3

This register contains the last 16 bytes mask values of the Wake-Up frame 1 pattern. Setting bit [0] selects the 49th byte of the Wake-Up frame 1. Setting bit [15] selects the 64th byte of the Wake-Up frame 1.

**TABLE 4-64: WAKE-UP FRAME 1 BYTE MASK 3 REGISTER (0X14A – 0X14B): WF1BM3**

Bit	Default	R/W	Description
15 - 0	0x0000	RW	<b>WF1BM3</b> Wake-Up Frame 1 Byte Mask 3. The last 16 byte mask covering bytes 49 to 64 of a wake-up frame 1 pattern.

4.2.17.25 0x14C – 0x14F: Reserved

4.2.17.26 Wake-Up Frame 2 CRC0 Register (0x150 – 0x151): WF2CRC0

This register contains the expected CRC values of the Wake-Up frame 2 pattern.

The value of the CRC calculated is based on the IEEE 802.3 Ethernet standard; it is taken over the bytes specified in the Wake-Up byte mask registers.

**TABLE 4-65: WAKE-UP FRAME 2 CRC0 REGISTER (0X150 – 0X151): WF2CRC0**

Bit	Default	R/W	Description
15 - 0	0x0000	RW	<b>WF2CRC0</b> Wake-Up Frame 2 CRC (lower 16 bits) The expected CRC value of a Wake-Up frame 2 pattern.

4.2.17.27 Wake-Up Frame 2 CRC1 Register (0x152 – 0x153): WF2CRC1

This register contains the expected CRC values of the Wake-Up frame 2 pattern.

The value of the CRC calculated is based on the IEEE 802.3 Ethernet standard; it is taken over the bytes specified in the Wake-Up byte mask registers.

**TABLE 4-66: WAKE-UP FRAME 2 CRC1 REGISTER (0X152 – 0X153): WF2CRC1**

Bit	Default	R/W	Description
15 - 0	0x0000	RW	<b>WF2CRC1</b> Wake-Up Frame 2 CRC (upper 16 bits). The expected CRC value of a Wake-Up frame 2 pattern.

4.2.17.28 Wake-Up Frame 2 Byte Mask 0 Register (0x154 – 0x155): WF2BM0

This register contains the first 16 bytes mask values of the Wake-Up frame 2 pattern. Setting bit [0] selects the first byte of the Wake-Up frame 2. Setting bit [15] selects the 16th byte of the Wake-Up frame 2.

**TABLE 4-67: WAKE-UP FRAME 2 BYTE MASK 0 REGISTER (0X154 – 0X155): WF2BM0**

Bit	Default	R/W	Description
15 - 0	0x0000	RW	<b>WF2BM0</b> Wake-Up Frame 2 Byte Mask 0 The first 16 byte mask of a Wake-Up frame 2 pattern.

4.2.17.29 Wake-Up Frame 2 Byte Mask 1 Register (0x156 – 0x157): WF2BM1

This register contains the next 16 bytes mask values of the Wake-Up frame 2 pattern. Setting bit [0] selects the 17th byte of the Wake-Up frame 2. Setting bit [15] selects the 32nd byte of the Wake-Up frame 2.

**TABLE 4-68: WAKE-UP FRAME 2 BYTE MASK 1 REGISTER (0X156 – 0X157): WF2BM1**

Bit	Default	R/W	Description
15 - 0	0x0000	RW	<b>WF2BM1</b> Wake-Up Frame 2 Byte Mask 1. The next 16 byte mask covering bytes 17 to 32 of a Wake-Up frame 2 pattern.

4.2.17.30 Wake-Up Frame 2 Byte Mask 2 Register (0x158 – 0x159): WF2BM2

This register contains the next 16 bytes mask values of the Wake-Up frame 2 pattern. Setting bit [0] selects the 33rd byte of the Wake-Up frame 2. Setting bit [15] selects the 48th byte of the Wake-Up frame 2.

**TABLE 4-69: WAKE-UP FRAME 2 BYTE MASK 2 REGISTER (0X158 – 0X159): WF2BM2**

Bit	Default	R/W	Description
15 - 0	0x0000	RW	<b>WF2BM2</b> Wake-Up Frame 2 Byte Mask 2. The next 16 byte mask covering bytes 33 to 48 of a wake-up frame 2 pattern.

# KSZ8441HL/FHL

## 4.2.17.31 Wake-Up Frame 2 Byte Mask 3 Register (0x15A – 0x15B): WF2BM3

This register contains the last 16 bytes mask values of the Wake-Up frame 2 pattern. Setting bit [0] selects the 49th byte of the Wake-Up frame 2. Setting bit [15] selects the 64th byte of the Wake-Up frame 2.

**TABLE 4-70: WAKE-UP FRAME 2 BYTE MASK 3 REGISTER (0X15A – 0X15B): WF2BM3**

Bit	Default	R/W	Description
15 - 0	0x0000	RW	<b>WF2BM3</b> Wake-Up Frame 2 Byte Mask 3. The last 16 byte mask covering bytes 49 to 64 of a wake-up frame 2 pattern.

## 4.2.17.32 0x15C – 0x15F: Reserved

## 4.2.17.33 Wake-Up Frame 3 CRC0 Register (0x160 – 0x161): WF3CRC0

This register contains the expected CRC values of the Wake-Up frame 3 pattern.

The value of the CRC calculated is based on the IEEE 802.3 Ethernet standard; it is taken over the bytes specified in the Wake-Up byte mask registers.

**TABLE 4-71: WAKE-UP FRAME 3 CRC0 REGISTER (0X160 – 0X161): WF3CRC0**

Bit	Default	R/W	Description
15 - 0	0x0000	RW	<b>WF3CRC0</b> Wake-Up Frame 3 CRC (lower 16 bits) The expected CRC value of a Wake-Up frame 3 pattern.

## 4.2.17.34 Wake-Up Frame 3 CRC1 Register (0x162 – 0x163): WF3CRC1

This register contains the expected CRC values of the Wake-Up frame 3 pattern.

The value of the CRC calculated is based on the IEEE 802.3 Ethernet standard; it is taken over the bytes specified in the Wake-Up byte mask registers.

**TABLE 4-72: WAKE-UP FRAME 3 CRC1 REGISTER (0X162 – 0X163): WF3CRC1**

Bit	Default	R/W	Description
15 - 0	0x0000	RW	<b>WF3CRC1</b> Wake-Up Frame 3 CRC (upper 16 bits). The expected CRC value of a Wake-Up frame 3 pattern.

## 4.2.17.35 Wake-Up Frame 3 Byte Mask 0 Register (0x164 – 0x165): WF3BM0

This register contains the first 16 bytes mask values of the Wake-Up frame 3 pattern. Setting bit [0] selects the first byte of the Wake-Up frame 3. Setting bit [15] selects the 16th byte of the Wake-Up frame 3.

**TABLE 4-73: WAKE-UP FRAME 3 BYTE MASK 0 REGISTER (0X164 – 0X165): WF3BM0**

Bit	Default	R/W	Description
15 - 0	0x0000	RW	<b>WF3BM0</b> Wake-Up Frame 3 Byte Mask 0 The first 16 byte mask of a Wake-Up frame 3 pattern.

## 4.2.17.36 Wake-Up Frame 3 Byte Mask 1 Register (0x166 – 0x167): WF3BM1

This register contains the next 16 bytes mask values of the Wake-Up frame 3 pattern. Setting bit [0] selects the 17th byte of the Wake-Up frame 3. Setting bit [15] selects the 32nd byte of the Wake-Up frame 3.

**TABLE 4-74: WAKE-UP FRAME 3 BYTE MASK 1 REGISTER (0X166 – 0X167): WF3BM1**

Bit	Default	R/W	Description
15 - 0	0x0000	RW	<b>WF3BM1</b> Wake-Up Frame 3 Byte Mask 1. The next 16 byte mask covering bytes 17 to 32 of a Wake-Up frame 3 pattern.

## 4.2.17.37 Wake-Up Frame 3 Byte Mask 2 Register (0x168 – 0x169): WF3BM2

This register contains the next 16 bytes mask values of the Wake-Up frame 3 pattern. Setting bit [0] selects the 33rd byte of the Wake-Up frame 3. Setting bit [15] selects the 48th byte of the Wake-Up frame 3.

**TABLE 4-75: WAKE-UP FRAME 3 BYTE MASK 2 REGISTER (0X168 – 0X169): WF3BM2**

Bit	Default	R/W	Description
15 - 0	0x0000	RW	<b>WF3BM2</b> Wake-Up Frame 3 Byte Mask 2. The next 16 byte mask covering bytes 33 to 48 of a wake-up frame 3 pattern.

## 4.2.17.38 Wake-Up Frame 3 Byte Mask 3 Register (0x16A – 0x16B): WF3BM3

This register contains the last 16 bytes mask values of the Wake-Up frame 3 pattern. Setting bit [0] selects the 49th byte of the Wake-Up frame 3. Setting bit [15] selects the 64th byte of the Wake-Up frame 3.

**TABLE 4-76: WAKE-UP FRAME 3 BYTE MASK 3 REGISTER (0X16A – 0X16B): WF3BM3**

Bit	Default	R/W	Description
15 - 0	0x0000	RW	<b>WF3BM3</b> Wake-Up Frame 3 Byte Mask 3. The last 16 byte mask covering bytes 49 to 64 of a wake-up frame 3 pattern.

## 4.2.17.39 0x16C – 0x16F: Reserved

## 4.2.18 INTERNAL I/O REGISTER SPACE MAPPING FOR THE QUEUE MANAGEMENT UNIT (0X170 – 0X1FF)

### 4.2.18.1 Transmit Control Register (0x170 – 0x171): TXCR

This register holds control information programmed by the CPU to control the QMU transmit module function.

**TABLE 4-77: TRANSMIT CONTROL REGISTER (0X170 – 0X171): TXCR**

Bit	Default	R/W	Description
15 - 9	—	RO	Reserved
8	0	RW	<b>TCGICMP Transmit Checksum Generation for ICMP</b> When this bit is set, the device hardware is enabled to generate an ICMP frame checksum in a non-fragmented ICMP frame.
7	0	RW	<b>TCGUDP Transmit Checksum Generation for UDP</b> When this bit is set, the device hardware is enabled to generate a UDP frame checksum in a non-fragmented UDP frame.
6	0	RW	<b>TCGTCP Transmit Checksum Generation for TCP</b> When this bit is set, the device hardware is enabled to generate a TCP frame checksum in a non-fragmented TCP frame.
5	0	RW	<b>TCGIP Transmit Checksum Generation for IP</b> When this bit is set, the device hardware is enabled to generate an IP header checksum in a non-fragmented IP frame.
4	0	RW	<b>FTXQ Flush Transmit Queue</b> When this bit is set, the transmit queue memory is cleared and TX frame pointer is reset. Note: Disable the TXE transmit enable bit[0] first before setting this bit, then clear this bit to normal operation.

# KSZ8441HL/FHL

**TABLE 4-77: TRANSMIT CONTROL REGISTER (0X170 – 0X171): TXCR (CONTINUED)**

Bit	Default	R/W	Description
3	0	RW	<b>TXFCE Transmit Flow Control Enable</b> When this bit is set and the device is in full-duplex mode, flow control is enabled. The device transmits a PAUSE frame when the receive buffer capacity reaches a threshold level that will cause the buffer to overflow. When this bit is set and the device is in half-duplex mode, back-pressure flow control is enabled. When this bit is cleared, no transmit flow control is enabled.
2	0	RW	<b>TXPE Transmit Padding Enable</b> When this bit is set, the device automatically adds a padding field to a packet shorter than 64 bytes. Note: Setting this bit requires enabling the add CRC feature (bit[1] = “1”) to avoid CRC errors for the transmit packet.
1	0	RW	<b>TXCE Transmit CRC Enable</b> When this bit is set, the device automatically adds a 32-bit CRC checksum field to the end of a transmit frame.
0	0	RW	<b>TXE Transmit Enable</b> When this bit is set, the transmit module is enabled and placed in a running state. When reset, the transmit process is placed in the stopped state after the transmission of the current frame is completed.

## 4.2.18.2 Transmit Status Register (0x172 – 0x173): TXSR

This register keeps the status of the last transmitted frame in the QMU transmit module.

**TABLE 4-78: TRANSMIT STATUS REGISTER (0X172 – 0X173): TXSR**

Bit	Default	R/W	Description
15 - 14	00	RO	Reserved
13	0	RO	<b>TXLC Transmit Late Collision</b> This bit is set when a transmit late collision occurs.
12	0	RO	<b>TXMC Transmit Maximum Collision</b> This bit is set when a transmit maximum collision is reached.
11 - 6	—	RO	Reserved
5 - 0	—	RO	<b>TXFID Transmit Frame ID</b> This field identifies the transmitted frame. All of the transmit status information in this register belongs to the frame with this ID.

## 4.2.18.3 Receive Control Register 1 (0x174 – 0x175): RXCR1

This register holds control information programmed by the host to control the receive function in the QMU module.

**TABLE 4-79: RECEIVE CONTROL REGISTER 1 (0X174 – 0X175): RXCR1**

Bit	Default	R/W	Description
15	0	RW	<b>FRXQ Flush Receive Queue</b> When this bit is set, The receive queue memory is cleared and RX frame pointer is reset. Note: Disable the RXE receive enable bit[0] first before setting this bit, then clear this bit for normal operation.
14	0	RW	<b>RXUDPFCC Receive UDP Frame Checksum Check Enable</b> While this bit is set, if any received UDP frame has an incorrect UDP checksum, the frame will be discarded.
13	0	RW	<b>RXTCPFCC Receive TCP Frame Checksum Check Enable</b> While this bit is set, if any received TCP frame has an incorrect TCP checksum, the frame will be discarded.



**TABLE 4-79: RECEIVE CONTROL REGISTER 1 (0X174 – 0X175): RXCR1 (CONTINUED)**

Bit	Default	R/W	Description
12	0	RW	<b>RXIPFCC Receive IP Frame Checksum Check Enable</b> While this bit is set, if any received IP frame has an incorrect IP checksum, the frame will be discarded.
11	1	RW	<b>RXPAFMA Receive Physical Address Filtering with MAC Address Enable</b> This bit enables the RX function to receive the physical address that passes the MAC Address filtering mechanism.
10	0	RW	<b>RXFCE Receive Flow Control Enable</b> When this bit is set and the device is in full-duplex mode, flow control is enabled, and the device will acknowledge a PAUSE frame from the receive interface; i.e., the outgoing packets are pending in the transmit buffer until the PAUSE frame control timer expires. This field has no meaning in half-duplex mode and should be programmed to “0”. When this bit is cleared, flow control is not enabled.
9	0	RW	<b>RXEFE Receive Error Frame Enable</b> When this bit is set, frames with CRC error are allowed to be received into the RX queue. When this bit is cleared, all CRC error frames are discarded.
8	0	RW	<b>RXMAFMA Receive Multicast Address Filtering with MAC Address Enable</b> When this bit is set, this bit enables the RX function to receive multicast address that pass the MAC Address filtering mechanism.
7	0	RW	<b>RXBE Receive Broadcast Enable</b> When this bit is set, the RX module is enabled to receive all the broadcast frames.
6	0	RW	<b>RXME Receive Multicast Enable</b> When this bit is set, the RX module is enabled to receive all the multicast frames (including broadcast frames).
5	0	RW	<b>RXUE Receive Unicast Enable</b> When this bit is set, the RX module is enabled to receive unicast frames that match the 48-bit station MAC address of the module.
4	0	RW	<b>RXAE Receive All Enable</b> When this bit is set, the device is enabled to receive all incoming frames, regardless of the frame’s destination address.
3 - 2	00	RW	Reserved
1	0	RW	<b>RXINVF Receive Inverse Filtering</b> When this bit is set, the device receives function with address check operation in inverse filtering mode.
0	0	RW	<b>RXE Receive Enable</b> When this bit is set, the RX block is enabled and placed in a running state. When this bit is cleared, the receive process is placed in the stopped state upon completing reception of the current frame.

#### 4.2.18.4 Receive Control Register 2 (0x176 – 0x177): RXCR2

This register holds control information programmed by the host to control the receive function in the QMU module.

**TABLE 4-80: RECEIVE CONTROL REGISTER 2 (0X176 – 0X177): RXCR2**

Bit	Default	R/W	Description
15 - 9	—	RO	Reserved

# KSZ8441HL/FHL

**TABLE 4-80: RECEIVE CONTROL REGISTER 2 (0X176 – 0X177): RXCR2 (CONTINUED)**

Bit	Default	R/W	Description
8	1	RW	<b>EQFCPT Enable QMU Flow Control Pause Timer</b> While this bit is set, another pause frame will be sent out if the pause timer is expired and RXQ (12 KB) is still above the low water mark. The pause timer will reset itself when it expires and RXQ is still above the low water mark and it will be disabled or stop counting when RXQ is below the low water mark. The pause frame is sent out before RXQ is above the high water mark.
7 - 5	000	RO	Reserved
4	1	RW	<b>IUFFP IPv4/IPv6/UDP Fragment Frame Pass</b> While this bit is set, the device will pass the frame without checking the UDP checksum at the received side for IPv6 UDP frames with a fragmented extension header. Operating with this bit cleared is not a valid mode since the hardware cannot calculate a correct UDP checksum without all of the IP fragments.
3	0	RW	Reserved
2	1	RW	<b>UDPLFE UDP Lite Frame Enable</b> While this bit is set, the KSZ8441 will check the checksum at receive side and generate the checksum at transmit side for UDP lite frame. While this bit is cleared, the KSZ8441 will pass the checksum check at receive side and skip the checksum generation at transmit side for UDP lite frame.
1	0	RW	<b>RXICMPFCC Receive ICMP Frame Checksum Check Enable</b> While this bit is set, any received ICMP frame (only a non-fragmented frame) with an incorrect checksum will be discarded. If this bit is not set, the frame will not be discarded even though there is an ICMP checksum error.
0	0	RW	<b>RXSAF Receive Source Address Filtering</b> While this bit is set, the device will drop the frame if the source address is the same as the MAC Address in the MARL, MARM, MARH registers.

## 4.2.18.5 TXQ Memory Information Register (0x178 – 0x179): TXMIR

This register indicates the amount of free memory available in the TXQ of the QMU module.

**TABLE 4-81: TXQ MEMORY INFORMATION REGISTER (0X178 – 0X179): TXMIR**

Bit	Default	R/W	Description
15 - 13	—	RO	Reserved
12 - 0	0x1800	RO	<b>TXMA Transmit Memory Available</b> The amount of memory available is represented in units of byte. The TXQ memory is used for both frame payload, control word. Note: Software must be written to ensure that there is enough memory for the next transmit frame including control information before transmit data is written to the TXQ.

## 4.2.18.6 0x17A – 0x17B: Reserved

## 4.2.18.7 Receive Frame Header Status Register (0x17C – 0x17D): RXFHSR

This register indicates the received frame header status information. The received frames are reported in the RXFC register. This register contains the status information for the frame received, and the host processor can read as many times as the frame count value in the RXFC register.

**TABLE 4-82: RECEIVE FRAME HEADER STATUS REGISTER (0X17C – 0X17D): RXFHSR**

Bit	Default	R/W	Description
15	—	RO	<b>RXFV Receive Frame Valid</b> This bit is set if the present frame in the receive packet memory is valid. The status information currently in this location is also valid. When clear, it indicates that there is either no pending receive frame or that the current frame is still in the process of receiving.
14	—	RO	Reserved
13	—	RO	<b>RXICMPFCS Receive ICMP Frame Checksum Status</b> When this bit is set, the KSZ8441 received ICMP frame checksum is incorrect.
12	—	RO	<b>RXIPFCS Receive IP Frame Checksum Status</b> When this bit is set, the KSZ8441 received IP header checksum is incorrect.
11	—	RO	<b>RXTCPFCS Receive TCP Frame Checksum Status</b> When this bit is set, the KSZ8441 received TCP frame checksum is incorrect.
10	—	RO	<b>RXUDPFCS Receive UDP Frame Checksum Status</b> When this bit is set, the KSZ8441 received UDP frame checksum is incorrect.
9 - 8	—	RO	Reserved
7	—	RO	<b>RXBF Receive Broadcast Frame</b> When this bit is set, it indicates that this frame has a broadcast address.
6	—	RO	<b>RXMF Receive Multicast Frame</b> When this bit is set, it indicates that this frame has a multicast address (including the broadcast address).
5	—	RO	<b>RXUF Receive Unicast Frame</b> When this bit is set, it indicates that this frame has a unicast address.
4	—	RO	Reserved
3	—	RO	<b>RXFT Receive Frame Type</b> When this bit is set, it indicates that the frame is an Ethernet-type frame (frame length is greater than 1500 bytes). When clear, it indicates that the frame is an IEEE 802.3 frame. This bit is not valid for “runt” frames.
2	—	RO	Reserved
1	—	RO	<b>RXRF Receive Runt Frame</b> When this bit is set, it indicates that a frame was damaged by a collision or had a premature termination before the collision window passed. “Runt” frames are passed to the host only if the Pass Bad Frame bit is set.
0	—	RO	<b>RXCE Receive CRC Error</b> When this bit is set, it indicates that a CRC error has occurred on the current received frame. CRC error frames are passed to the host only if the Pass Bad Frame bit is set.

# KSZ8441HL/FHL

## 4.2.18.8 Receive Frame Header Byte Count Register (0x17E – 0x17F): RXFHBCR

This register indicates the received frame header byte count information. The received frames are reported in the RXFC register. This register contains the total number of bytes information for the frame received, and the host processor can read as many times as the frame count value in the RXFC register.

**TABLE 4-83: RECEIVE FRAME HEADER BYTE COUNT REGISTER (0X17E – 0X17F): RXFHBCR**

Bit	Default	R/W	Description
15 - 12	—	RO	Reserved
11 - 0	—	RO	<b>RXBC Receive Byte Count</b> This field indicates the present received frame byte size. Note: Always read low byte first for 8-bit mode operation.

## 4.2.18.9 TXQ Command Register (0x180 – 0x181): TXQCR

This register is programmed by the host CPU to issue a transmit command to the TXQ. The present transmit frame in the TXQ memory is queued for transmit.

**TABLE 4-84: TXQ COMMAND REGISTER (0X180 – 0X181): TXQCR**

Bit	Default	R/W	Description
15 - 3	—	RW	Reserved
2	0	RW	Reserved
1	0	RW	<b>TXQMAM TXQ Memory Available Monitor</b> When this bit is written as a “1”, the KSZ8441 will generate interrupt (bit [6] in the ISR register) to the CPU when TXQ memory is available based upon the total amount of TXQ space requested by CPU at TXNTFSR (0x19E) register. Note: This bit is self-clearing after the frame is finished transmitting. The software should wait for the bit to be cleared before setting to “1” again.
0	0	RW	<b>METF Manual Enqueue TXQ Frame Enable</b> When this bit is written as “1”, the KSZ8441 will enable the current TX frame in the TX buffer to be queued for transmit one frame at a time. Note: This bit is self-cleared after the frame transmission is complete. The software should wait for the bit to be cleared before setting up another new TX frame.

## 4.2.18.10 RXQ Command Register (0x182 – 0x183): RXQCR

This register is programmed by the host CPU to issue DMA read or write command to the RXQ and TXQ. This register also is used to control all RX thresholds enable and status.

**TABLE 4-85: RXQ COMMAND REGISTER (0X182 – 0X183): RXQCR**

Bit	Default	R/W	Description
15 - 13	—	RW	Reserved
12	—	RO	<b>RXDTTS RX Duration Timer Threshold Status</b> When this bit is set, it indicates that RX interrupt is due to the time starting at the first received frame in the RXQ buffer exceeding the threshold set in the RX Duration Timer Threshold Register (0x18C, RXDTTR). This bit will be updated when a “1” is written to bit [13] in the ISR register.
11	—	RO	<b>RXDBCTS RX Data Byte Count Threshold Status</b> When this bit is set, it indicates that the RX interrupt is due to the number of received bytes in RXQ buffer exceeding the threshold set in the RX Data Byte Count Threshold register (0x18E, RXDBCTR). This bit will be updated when a “1” is written to bit [13] in the ISR register.

**TABLE 4-85: RXQ COMMAND REGISTER (0X182 – 0X183): RXQCR (CONTINUED)**

Bit	Default	R/W	Description
10	—	RO	<b>RXFCTS RX Frame Count Threshold Status</b> When this bit is set, it indicates that the RX interrupt is due to the number of received frames in RXQ buffer exceeding the threshold set in the RX Frame Count Threshold register (0x19C, RXFCTR). This bit will be updated when a “1” is written to bit [13] in the ISR register.
9	0	RW	<b>RXIPHTOE RX IP Header Two-Byte Offset Enable</b> When this bit is written as “1”, the device will enable the adding of two bytes before the frame header in order for the IP header inside the frame contents to be aligned with a double word boundary to speed up software operation.
8	—	RW	Reserved
7	0	RW	<b>RXDTTE RX Duration Timer Threshold Enable</b> When this bit is written as “1”, the device will enable the RX interrupt (bit [13] in the ISR) when the time starts at the first received frame in the RXQ buffer if it exceeds the threshold set in the RX Duration Timer Threshold register (0x18C, RXDTTR).
6	0	RW	<b>RXDBCTE RX Data Byte Count Threshold Enable</b> When this bit is written as “1”, the device will enable the RX interrupt (bit [13] in ISR) when the number of received bytes in the RXQ buffer exceeds the threshold set in the RX Data Byte Count Threshold register (0x18E, RXDBCTR).
5	0	RW	<b>RXFCTE RX Frame Count Threshold Enable</b> When this bit is written as “1”, the device will enable the RX interrupt (bit [13] in ISR) when the number of received frames in the RXQ buffer exceeds the threshold set in the RX Frame Count Threshold register (0x19C, RXFCTR).
4	0	RW	<b>ADRFE Auto-Dequeue RXQ Frame Enable</b> When this bit is written as “1”, the device will automatically enable RXQ frame buffer dequeue. The read pointer in the RXQ frame buffer will be automatically adjusted to the next received frame location after the current frame is completely read by the host.
3	0	RW	<b>SDA Start DMA Access</b> When this bit is written as “1”, the device allows a DMA operation from the host CPU to access either the read RXQ frame buffer or the write TXQ frame buffer with CSN and RDN or WRN signals while the CMD pin is low. All register accesses are disabled except for access to this register during this DMA operation. This bit must be set to “0” when the DMA operation is finished in order to access the rest of the registers.
2 - 1	—	RW	Reserved
0	0	RW	<b>RRXEF Release RX Error Frame</b> When this bit is written as “1”, the current RX error frame buffer is released. Note: This bit is self-cleared after the frame memory is released. The software should wait for the bit to be cleared before processing a new RX frame.

# KSZ8441HL/FHL

## 4.2.18.11 TX Frame Data Pointer Register (0x184 – 0x185): TXFDPR

The value of this register determines the address to be accessed within the TXQ frame buffer. When the auto increment is set, it will automatically increment the pointer value on write accesses to the data register.

The counter is incremented by one for every byte access, by two for every word access, and by four for every double word access.

**TABLE 4-86: TX FRAME DATA POINTER REGISTER (0X184 – 0X185): TXFDPR**

Bit	Default	R/W	Description
15	—	RO	Reserved
14	0	RW	<b>TXFPAI TX Frame Data Pointer Auto Increment</b> 1: When this bit is set, the TX Frame Data Pointer register increments automatically on accesses to the data register. The increment is by one for every byte access, by two for every word access, and by four for every double word access. 0: When this bit is reset, the TX Frame Data Pointer is manually controlled by the user to access the TX frame location.
13 - 11	—	RO	Reserved
10 - 0	0x000	RO	<b>TXFP TX Frame Data Pointer</b> TX frame pointer index to the Frame Data register for access. This field is reset to the next available TX frame location when the TX frame data has been enqueued through the TXQ command register.

## 4.2.18.12 RX Frame Data Pointer Register (0x186 – 0x187): RXFDPR

Bits [10:0] of this register determine the address to be accessed within the RXQ frame buffer. When the auto increment function is set, it will automatically increment the RXQ Pointer on read accesses to the data register. The counter is incremented is by one for every byte access, by two for every word access, and by four for every double word access.

**TABLE 4-87: RX FRAME DATA POINTER REGISTER (0X186 – 0X187): RXFDPR**

Bit	Default	R/W	Description
15	—	RO	Reserved
14	0	RW	<b>RXFPAI RX Frame Pointer Auto Increment</b> 1 = When this bit is set, the RXQ Address register increments automatically on accesses to the data register. The increment is by one for every byte access, by two for every word access, and by four for every double word access. 0 = When this bit is reset, the RX frame data pointer is manually controlled by user to access the RX frame location.
13	—	RO	Reserved
12	1	RW	<b>WST Write Sample Time</b> This bit is used to select the WRN active to write data valid time. 0 = WRN active to write data valid sample time is range of 8 ns (minimum) to 16 ns (maximum). 1 = WRN active to write data valid sample time is 4 ns (maximum).
11	—	RW	<b>EMS Endian Mode Selection</b> This bit indicates the mode of the 8/16-bit host interface, either big endian or little endian. The mode is determined at reset or power up by the strap-in function on pin 62, and should not be changed when writing to this register. 0 = Set to little endian mode 1 = Set to big endian mode
10 - 0	0x000	WO	<b>RXFP RX Frame Pointer</b> RX Frame data pointer index to the data register for access. This pointer value must reset to 0x000 before each DMA operation from the host CPU to read RXQ frame buffer.

4.2.18.13 0x188 – 0x18B: Reserved

4.2.18.14 RX Duration Timer Threshold Register (0x18C – 0x18D): RXDTTR

This register is used to program the received frame duration timer threshold.

**TABLE 4-88: RX DURATION TIMER THRESHOLD REGISTER (0X18C – 0X18D): RXDTTR**

Bit	Default	R/W	Description
15 - 0	0x0000	RW	<b>RXDTT Receive Duration Timer Threshold</b> These bits are used to program the “received frame duration timer threshold” value in 1 $\mu$ s increments. The maximum value is 0xCFFF. When bit [7] is set to “1” in RXQCR register, the KSZ8441 will set the RX interrupt (bit [13] in ISR) after the timer starts at the first received frame in the RXQ buffer and when it exceeds the threshold set in this register.

4.2.18.15 RX Data Byte Count Threshold Register (0x18E – 0x18F): RXDBCTR

This register is used to program the received data byte count threshold.

**TABLE 4-89: RX DATA BYTE COUNT THRESHOLD REGISTER (0X18E – 0X18F): RXDBCTR**

Bit	Default	R/W	Description
15 - 0	0x0000	RW	<b>RXDBCT Receive Data Byte Count Threshold</b> These bits are used to program the “received data byte threshold” value in byte count. When bit [6] is set to “1” in RXQCR register, the KSZ8441 will set the RX interrupt (bit [13] in ISR) when the number of received bytes in the RXQ buffer exceeds the threshold set in this register.

4.2.19 INTERNAL I/O REGISTER SPACE MAPPING FOR INTERRUPT REGISTERS (0X190 – 0X193)

4.2.19.1 Interrupt Enable Register (0x190 – 0x191): IER

This register enables the interrupts from the QMU, PTP, and other sources.

**TABLE 4-90: INTERRUPT ENABLE REGISTER (0X190 – 0X191): IER**

Bit	Default	R/W	Description
15	0	RW	<b>LCIE Link Change Interrupt Enable</b> 1 = When this bit is set, the link change interrupt is enabled. 0 = When this bit is reset, the link change interrupt is disabled.
14	0	RW	<b>TXIE Transmit Interrupt Enable</b> 1 = When this bit is set, the transmit interrupt is enabled. 0 = When this bit is reset, the transmit interrupt is disabled.
13	0	RW	<b>RXIE Receive Interrupt Enable</b> 1 = When this bit is set, the receive interrupt is enabled. 0 = When this bit is reset, the receive interrupt is disabled.
12	0	RO	<b>PTP Time Stamp Interrupt Enable</b> This status bit is an “OR” of the PTP_TS_IE[11:0] bits. Clearing the appropriate enable bit in the PTP_TS_IE register (0x68E – 0x68F) or clearing the appropriate status bit in the PTP_TS_IS register (0x68C – 0x68D) will clear this bit. When writing this register, always write this bit as a zero.
11	0	RW	<b>RXOIE Receive Overrun Interrupt Enable</b> 1 = When this bit is set, the receive overrun interrupt is enabled. 0 = When this bit is reset, the receive overrun interrupt is disabled.

# KSZ8441HL/FHL

**TABLE 4-90: INTERRUPT ENABLE REGISTER (0X190 – 0X191): IER (CONTINUED)**

Bit	Default	R/W	Description
10	0	RO	<b>PTP Trigger Output Unit Interrupt Enable</b> This status bit is an “OR” of the PTP_TRIG_IE[11:0] bits. Clearing the appropriate enable bit in the PTP_TRIG_IE register (0x68A – 0x68B) or clearing the appropriate status bit in the PTP_TRIG_IS register (0x688 – 0x689) will clear this bit. When writing this register, always write this bit as a zero.
9	0	RW	<b>TXPSIE Transmit Process Stopped Interrupt Enable</b> 1 = When this bit is set, the transmit process stopped interrupt is enabled. 0 = When this bit is reset, the transmit process stopped interrupt is disabled.
8	0	RW	<b>RXPSIE Receive Process Stopped Interrupt Enable</b> 1 = When this bit is set, the receive process stopped interrupt is enabled. 0 = When this bit is reset, the receive process stopped interrupt is disabled.
7	0	RW	Reserved
6	0	RW	<b>TXSAIE Transmit Space Available Interrupt Enable</b> 1 = When this bit is set, the transmit memory space available interrupt is enabled. 0 = When this bit is reset, the transmit memory space available interrupt is disabled.
5	0	RW	<b>RXWFDIE Receive Wake-Up Frame Detect Interrupt Enable</b> 1 = When this bit is set, the receive Wake-Up frame detect interrupt is enabled. 0 = When this bit is reset, the receive Wake-Up frame detect interrupt is disabled.
4	0	RW	<b>RXMPDIE Receive Magic Packet Detect Interrupt Enable</b> 1 = When this bit is set, the receive Magic Packet detect interrupt is enabled. 0 = When this bit is reset, the receive Magic Packet detect interrupt is disabled.
3	0	RW	<b>LDIE Linkup Detect Interrupt Enable</b> 1 = When this bit is set, the wake-up from a link up detect interrupt is enabled. 0 = When this bit is reset, the link up detect interrupt is disabled.
2	0	RW	<b>EDIE Energy Detect Interrupt Enable</b> 1 = When this bit is set, the wake-up from energy detect interrupt is enabled. 0 = When this bit is reset, the energy detect interrupt is disabled.
1 - 0	00	RO	Reserved

## 4.2.19.2 Interrupt Status Register (0x192 – 0x193): ISR

This register contains the status bits for all interrupt sources.

When the corresponding enable bit is set, it causes the interrupt pin to be asserted.

This register is usually read by the host CPU and device drivers during an interrupt service routine or polling. The register bits are not cleared when read. The user has to write a “1” to clear.



**TABLE 4-91: INTERRUPT STATUS REGISTER (0X192 – 0X193): ISR**

Bit	Default	R/W	Description
15	0	RO (W1C)	<b>LCIS Link Change Interrupt Status</b> When this bit is set, it indicates that the link status has changed from link up to link down, or link down to link up. This edge-triggered interrupt status is cleared by writing a “1” to this bit.
14	0	RO (W1C)	<b>TXIS Transmit Interrupt Status</b> When this bit is set, it indicates that the TXQ MAC has transmitted at least a frame on the MAC interface and the QMU TXQ is ready for new frames from the host. This edge-triggered interrupt status is cleared by writing a “1” to this bit.
13	0	RO (W1C)	<b>RXIS Receive Interrupt Status</b> When this bit is set, it indicates that the QMU RXQ has received at least a frame from the MAC interface and the frame is ready for the host CPU to process. This edge-triggered interrupt status is cleared by writing a “1” to this bit.
12	0	RO (W1C)	<b>PTP Time Stamp Interrupt Status</b> When this bit is set, it indicates that one of 12 time stamp input units is ready (TS_RDY = “1”) or the egress time stamp is available from either port 1 or port 2. This edge-triggered interrupt status is cleared by writing a “1” to this bit.
11	0	RO (W1C)	<b>RXOIS Receive Overrun Interrupt Status</b> When this bit is set, it indicates that the receive overrun status has occurred. This edge-triggered interrupt status is cleared by writing a “1” to this bit.
10	0	RO (W1C)	<b>PTP Trigger Unit Interrupt Status</b> When this bit is set, it indicates that one of 12 trigger output units is done or has an error. This edge-triggered interrupt status is cleared by writing a “1” to this bit.
9	0	RO (W1C)	<b>TXPSIS Transmit Process Stopped Interrupt Status</b> When this bit is set, it indicates that the transmit process has stopped. This edge-triggered interrupt status is cleared by writing a “1” to this bit.
8	0	RO (W1C)	<b>RXPSIS Receive Process Stopped Interrupt Status</b> When this bit is set, it indicates that the receive process has stopped. This edge-triggered interrupt status is cleared by writing a “1” to this bit.
7	0	RO	Reserved
6	0	RO (W1C)	<b>TXSAIS Transmit Space Available Interrupt Status</b> When this bit is set, it indicates that transmit memory space available status has occurred.
5	0	RO	<b>RXWFDIS Receive Wake-Up Frame Detect Interrupt Status</b> When this bit is set, it indicates that a Wake-Up frame has been received. Write 1000 to PMCTRL[5:2] to clear this bit.
4	0	RO	<b>RXMPDIS Receive Magic Packet Detect Interrupt Status</b> When this bit is set, it indicates that a Magic Packet has been received. Write 0100 to PMCTRL[5:2] to clear this bit.
3	0	RO	<b>LDIS Linkup Detect Interrupt Status</b> When this bit is set, it indicates that wake-up from linkup detect status has occurred. Write 0010 to PMCTRL[5:2] to clear this bit.
2	0	RO	<b>EDIS Energy Detect Interrupt Status</b> When this bit is set and bit [2] = “1”, bit [0] = “0” in the IER register, it indicates that wake-up from energy detect status has occurred. When this bit is set and bit [2, 0] = “1” in the IER register, it indicates that wake-up from energy detect status has occurred. Write 0001 to PMCTRL[5:2] to clear this bit.

# KSZ8441HL/FHL

**TABLE 4-91: INTERRUPT STATUS REGISTER (0X192 – 0X193): ISR (CONTINUED)**

Bit	Default	R/W	Description
1 - 0	00	RO	Reserved

4.2.19.3 0x194 – 0x19B: Reserved

4.2.20 INTERNAL I/O REGISTER SPACE MAPPING FOR THE QUEUE MANAGEMENT UNIT (0X19C – 0X1B9)

4.2.20.1 RX Frame Count and Threshold Register (0x19C – 0x19D): RXFCTR

This register is used to program the received frame count threshold.

**TABLE 4-92: RX FRAME COUNT AND THRESHOLD REGISTER (0X19C – 0X19D): RXFCTR**

Bit	Default	R/W	Description
15 - 8	0x00	RW	Reserved
7 - 0	0x00	RW	<b>RXFCT Receive Frame Count Threshold</b> This register is used to program the received frame count threshold value. When bit [5] set to “1” in RXQCR register, the KSZ8441 will set RX interrupt (bit [13] in ISR) when the number of received frames in RXQ buffer exceeds the threshold set in this register.

4.2.20.2 TX Next Total Frames Size Register (0x19E – 0x19F): TXNTFSR

This register is used by the Host CPU to program the total amount of TXQ buffer space requested for the next transmit.

**TABLE 4-93: TX NEXT TOTAL FRAMES SIZE REGISTER (0X19E – 0X19F): TXNTFSR**

Bit	Default	R/W	Description
15 - 0	0x0000	RW	<b>TXNTFS TX Next Total Frames Size</b> The host CPU is used to program the total amount of TXQ buffer space which is required for next total transmit frames size in double-word count. When bit [1] (TXQ memory available monitor) is set to “1” in TXQCR register, the KSZ8441 will generate interrupt (bit [6] in ISR register) to CPU when TXQ memory is available based upon the total amount of TXQ space requested by CPU at this register.

4.2.20.3 MAC Address Hash Table Register 0 (0x1A0 – 0x1A1): MAHTR0

The 64-bit MAC address table is used for group address filtering and it is enabled by selecting “Hash perfect” mode. This value is defined as the six most significant bits from CRC circuit calculation result that is based on 48-bit of DA input. The two most significant bits select one of the four registers to be used, while the others determine which bit within the register.

**TABLE 4-94: MULTICAST TABLE REGISTER 0**

Bit	Default	R/W	Description
15 - 0	0x0000	RW	<b>HT0 Hash Table 0</b> When the appropriate bit is set, if the packet received with DA matches the CRC, the hashing function is received without being filtered. When the appropriate bit is cleared, the packet will be dropped. Note: When “Receive All” (RXCR1, bit[4]) and the “Receive Multicast Addr. Filtering with the MAC Address” (RXCR1, bit[8]) bit is set, all multicast addresses are received regardless of the multicast table value.

## 4.2.20.4 MAC Address Hash Table Register 1 (0x1A2 – 0x1A3): MAHTR1

**TABLE 4-95: MULTICAST TABLE REGISTER 1**

Bit	Default	R/W	Description
15 - 0	0x0000	RW	<b>HT1 Hash Table 1</b> When the appropriate bit is set, if the packet received with DA matches the CRC, the hashing function is received without being filtered. When the appropriate bit is cleared, the packet will be dropped. Note: When “Receive All” (RXCR1, bit[4]) and the “Receive Multicast Addr. Filtering with the MAC Address” (RXCR1, bit[8]) bit is set, all multi-cast addresses are received regardless of the multicast table value.

## 4.2.20.5 MAC Address Hash Table Register 2 (0x1A4 – 0x1A5): MAHTR2

**TABLE 4-96: MULTICAST TABLE REGISTER 2**

Bit	Default	R/W	Description
15 - 0	0x0000	RW	<b>HT2 Hash Table 2</b> When the appropriate bit is set, if the packet received with DA matches the CRC, the hashing function is received without being filtered. When the appropriate bit is cleared, the packet will be dropped. Note: When “Receive All” (RXCR1, bit[4]) and the “Receive Multicast Addr. Filtering with the MAC Address” (RXCR1, bit[8]) bit is set, all multi-cast addresses are received regardless of the multicast table value.

## 4.2.20.6 MAC Address Hash Table Register 3 (0x1A6 – 0x1A7): MAHTR3

**TABLE 4-97: MULTICAST TABLE REGISTER 3**

Bit	Default	R/W	Description
15 - 0	0x0000	RW	<b>HT3 Hash Table 3</b> When the appropriate bit is set, if the packet received with DA matches the CRC, the hashing function is received without being filtered. When the appropriate bit is cleared, the packet will be dropped. Note: When “Receive All” (RXCR1, bit[4]) and the “Receive Multicast Addr. Filtering with the MAC Address” (RXCR1, bit[8]) bit is set, all multi-cast addresses are received regardless of the multicast table value.

## 4.2.20.7 0x1A8 – 0x1AF: Reserved

## 4.2.20.8 Flow Control Low Water Mark Register (0x1B0 – 0x1B1): FCLWR

This register is used to control the flow control for low water mark in QMU RX queue.

**TABLE 4-98: FLOW CONTROL LOW WATER MARK REGISTER (0X1B0 – 0X1B1): FCLWR**

Bit	Default	R/W	Description
15 - 12	—	RW	Reserved
11 - 0	0x600	RW	<b>FCLWC Flow Control Low Water Mark Configuration</b> These bits define the QMU RX queue low water mark configuration. It is in double words count and default is 6 KB available buffer space out of 12 KB.

# KSZ8441HL/FHL

## 4.2.20.9 Flow Control High Water Mark Register (0x1B2 – 0x1B3): FCHWR

This register is used to control the flow control for high water mark in QMU RX queue.

**TABLE 4-99: FLOW CONTROL HIGH WATER MARK REGISTER (0X1B2 – 0X1B3): FCHWR**

Bit	Default	R/W	Description
15 - 12	—	RW	Reserved
11 - 0	0x400	RW	<b>FCHWC Flow Control High Water Mark Configuration</b> These bits define the QMU RX queue high water mark configuration. It is in double words count and default is 4 KB available buffer space out of 12 KB.

## 4.2.20.10 Flow Control Overrun Water Mark Register (0x1B4 – 0x1B5): FCOWR

This register is used to control the flow control for overrun water mark in QMU RX queue.

**TABLE 4-100: FLOW CONTROL OVERRUN WATER MARK REGISTER (0X1B4 – 0X1B5): FCOWR**

Bit	Default	R/W	Description
15 - 12	—	RW	Reserved
11 - 0	0x040	RW	<b>FCLWC Flow Control Overrun Water Mark Configuration</b> These bits define the QMU RX queue overrun water mark configuration. It is in double words count and default is 256 bytes available buffer space out of 12 KB.

## 4.2.20.11 0x1B6 – 0x1B7: Reserved

## 4.2.20.12 RX Frame Count Register (0x1B8 – 0x1B9): RXFC

This register indicates the current total amount of received frame count in RXQ frame buffer.

**TABLE 4-101: RX FRAME COUNT REGISTER (0X1B8 – 0X1B9): RXFC**

Bit	Default	R/W	Description
15 - 8	0x00	RO	<b>RXFC RX Frame Count</b> Indicates the total received frames in RXQ frame buffer when the receive interrupt (bit [13] = “1” in the ISR) occurred and a '1' is written to clear this bit [13] in the ISR. The host CPU can start to read the updated receive frame header information in RXFHSR/RXFHBCR registers after reading the RX frame count register
7 - 0	0x00	RW	Reserved

## 4.2.20.13 0x1BA – 0x1FF: Reserved

## 4.2.21 INTERNAL I/O REGISTER SPACE MAPPING FOR TRIGGER OUTPUT UNITS (12 UNITS, 0X200 – 0X3FF)

### 4.2.21.1 Trigger Error Register (0x200 – 0x201): TRIG\_ERR

This register contains the trigger output unit error status.

**TABLE 4-102: TRIGGER ERROR REGISTER (0X200 – 0X201): TRIG\_ERR**

Bit	Default	R/W	Description
15 - 12	0x0	RO	Reserved

**TABLE 4-102: TRIGGER ERROR REGISTER (0X200 – 0X201): TRIG\_ERR (CONTINUED)**

Bit	Default	R/W	Description
11 - 0	0x000	RO	<b>Trigger Output Unit Error</b> 1 = The trigger time is set earlier than the system time clock when TRIG_NOTIFY bit is set to "1" in TRIG_CFG1 register and it will generate interrupt to host if interrupt enable bit is set in PTP_TRIG_IE register. This bit can be cleared by resetting the TRIG_EN bit to "0". 0 = No trigger output unit error. There are 12 trigger output units and therefore there is a corresponding Error bit for each of the trigger output units, bit[11:0] = unit[12:1].

4.2.21.2 Trigger Active Register (0x202 – 0x203): TRIG\_ACTIVE

This register contains the trigger output unit active status.

**TABLE 4-103: TRIGGER ACTIVE REGISTER (0X202 – 0X203): TRIG\_ACTIVE**

Bit	Default	R/W	Description
15 - 12	0x0	RO	Reserved
11 - 0	0x000	RO	<b>Trigger Output Unit Active</b> 1 = The trigger output unit is enabled and active without error. 0 = The trigger output unit is finished and inactive. There are 12 trigger output units and therefore there is a corresponding active bit for each of the trigger output units, bit[11:0] = unit[12:1].

4.2.21.3 Trigger Done Register (0x204 – 0x205): TRIG\_DONE

This register contains the trigger output unit event done status.

**TABLE 4-104: TRIGGER DONE REGISTER (0X204 – 0X205): TRIG\_DONE**

Bit	Default	R/W	Description
15 - 12	0x0	RO	Reserved
11 - 0	0x000	RO (W1C)	<b>Trigger Output Unit Event Done</b> 1 = The trigger output unit event has been generated when TRIG_NOTIFY bit is set to "1" in TRIG_CFG1 register (write "1" to clear this bit) and it will generate interrupt to host if interrupt enable bit is set in PTP_TRIG_IE register. 0 = The trigger output unit event is not generated. There are 12 trigger output units and therefore there is a corresponding Done bit for each of the trigger output units, bit[11:0] = unit[12:1].

4.2.21.4 Trigger Enable Register (0x206 – 0x207): TRIG\_EN

This register contains the trigger output unit enable control bits.

**TABLE 4-105: TRIGGER ENABLE REGISTER (0X206 – 0X207): TRIG\_EN**

Bit	Default	R/W	Description
15 - 12	0x0	RO	Reserved
11 - 0	0x000	RW	<b>Trigger Output Unit Enable</b> 1 = Enables the selected trigger output unit and will self-clear when the trigger output is generated. In cascade mode, only enable the head of trigger unit. 0 = The trigger output unit is disabled. There are 12 trigger output units and therefore there is a corresponding enable bit for each of the trigger output units, bit[11:0] = unit[12:1].

# KSZ8441HL/FHL

## 4.2.21.5 Trigger Software Reset Register (0x208 – 0x209): TRIG\_SW\_RST

This register contains the software reset bits for the trigger output units.

**TABLE 4-106: TRIGGER SOFTWARE RESET REGISTER (0X208 – 0X209): TRIG\_SW\_RST**

Bit	Default	R/W	Description
15 - 12	0x0	RO	Reserved
11 - 0	0x000	RW/SC	<b>Trigger Output Unit Software Reset</b> 1 = When set, the selected trigger output unit is put into the inactive state and default setting. This can be used to stop the cascade mode in continuous operation and prepare the selected trigger unit for the next operation. 0 = While zero, the selected trigger output unit is in normal operating mode. There are 12 trigger output units and therefore there is a corresponding software reset bit for each of the trigger output units, bit[11:0] = unit[12:1].

## 4.2.21.6 Trigger Output Unit 12 Output PPS Pulse-Width Register (0x20A – 0x20B): TRIG12\_PPS\_WIDTH

This register contains the trigger output unit 12 PPS pulse width and trigger output unit 1 path delay compensation.

**TABLE 4-107: TRIGGER OUTPUT UNIT 12 OUTPUT PPS PULSE-WIDTH REGISTER (0X20A – 0X20B): TRIG12\_PPS\_WIDTH**

Bit	Default	R/W	Description
15 - 12	0x0	RO	Reserved
11	0	RW	Reserved
10 - 8	000	RW	<b>Path Delay Compensation for Trigger Output Unit 1</b> These three bits are used to compensate the path delay of clock skew for event trigger output unit 1 in the range of 0 ns ~ 7 ns (bit[11] = "1") or 0 ns ~ 28 ns (bit[11] = "0").
7 - 0	0x00	RW	<b>PPS Pulse Width for Trigger Output Unit 12</b> This is upper third byte [23:16] in conjunction with the unit 12 trigger output pulse width in TRIG12_CFG_2[15:0] (0x38A) register to make this register value for PPS pulse width up to 134 ms.

## 4.2.21.7 0x20C – 0x21F: Reserved

## 4.2.21.8 Trigger Output Unit 1 Target Time in Nanoseconds Low-Word Register (0x220 – 0x221): TRIG1\_TGT\_NSL

This register contains the trigger output unit 1 target time in nanoseconds low-word.

**TABLE 4-108: TRIGGER OUTPUT UNIT 1 TARGET TIME IN NANoseconds LOW-WORD REGISTER (0X220 – 0X221): TRIG1\_TGT\_NSL**

Bit	Default	R/W	Description
15 - 0	0x0000	RW	<b>Trigger Output Unit 1 Target Time in Nanoseconds Low-Word [15:0]</b> This is low-word of target time for trigger output unit 1 in nanoseconds.

## 4.2.21.9 Trigger Output Unit 1 Target Time in Nanoseconds High-Word Register (0x222 – 0x223): TRIG1\_TGT\_NSH

This register contains the trigger output unit 1 target time in nanoseconds high-word.

**TABLE 4-109: TRIGGER OUTPUT UNIT 1 TARGET TIME IN NANoseconds HIGH-WORD REGISTER (0X222 – 0X223): TRIG1\_TGT\_NSH**

Bit	Default	R/W	Description
15 - 14	00	RO	Reserved

**TABLE 4-109: TRIGGER OUTPUT UNIT 1 TARGET TIME IN NANoseconds HIGH-WORD REGISTER (0X222 – 0X223): TRIG1\_TGT\_NSH (CONTINUED)**

Bit	Default	R/W	Description
13 - 0	0x0000	RW	<b>Trigger Output Unit 1 Target Time in Nanoseconds High-Word [29:16]</b> This is high-word of target time for trigger output unit 1 in nanoseconds.

4.2.21.10 Trigger Output Unit 1 Target Time in Seconds Low-Word Register (0x224 – 0x225): TRIG1\_TGT\_SL

This register contains the trigger output unit 1 target time in seconds low-word.

**TABLE 4-110: TRIGGER OUTPUT UNIT 1 TARGET TIME IN SECONDS LOW-WORD REGISTER (0X224 – 0X225): TRIG1\_TGT\_SL**

Bit	Default	R/W	Description
15 - 0	0x0000	RW	<b>Trigger Output Unit 1 Target Time in Seconds Low-Word [15:0]</b> This is low-word of target time for trigger output unit 1 in seconds.

4.2.21.11 Trigger Output Unit 1 Target Time in Seconds High-Word Register (0x226 – 0x227): TRIG1\_TGT\_SH

This register contains the trigger output unit 1 target time in seconds high-word.

**TABLE 4-111: TRIGGER OUTPUT UNIT 1 TARGET TIME IN SECONDS HIGH-WORD REGISTER (0X226 – 0X227): TRIG1\_TGT\_SH**

Bit	Default	R/W	Description
15 - 0	0x0000	RW	<b>Trigger Output Unit 1 Target Time in Seconds High-Word [31:16]</b> This is high-word of target time for trigger output unit 1 in seconds.

4.2.21.12 Trigger Output Unit 1 Configuration and Control Register 1 (0x228 – 0x229): TRIG1\_CFG\_1

This register (1 of 8) contains the trigger output unit 1 configuration and control bits.

**TABLE 4-112: TRIGGER OUTPUT UNIT 1 CONFIGURATION AND CONTROL REGISTER 1 (0X228 – 0X229): TRIG1\_CFG\_1**

Bit	Default	R/W	Description
15	0	RW	<b>Enable This Trigger Output Unit in Cascade Mode</b> 1 = Enable this trigger output unit in cascade mode. 0 = disable this trigger output unit in cascade mode.
14	0	RW	<b>Indicate a Tail Unit for This Trigger Output Unit in Cascade Mode</b> 1 = This trigger output unit is the last unit of the chain in cascade mode. 0 = This trigger output unit is not the last unit of a chain in cascade mode. <b>Note:</b> When this bit is set "0" in all CFG_1 trigger units, and all units are in cascade mode, the iteration count is ignored and it becomes infinite. To stop the infinite loop, set the respective bit[11:0] in TRIG_SW_RST register.
13 - 10	0xF	RW	<b>Select Upstream Trigger Unit in Cascade Mode</b> These bits are used to select one of the 12 upstream trigger output units in Cascade mode. <b>Note:</b> 0x0 indicates TOU1, and 0xB indicates TOU12. (0xC to 0xF are not used.) For example, if units 1, 2 and 3 (tail unit) are set up in cascade mode, then these 4 bits are set as follows at the three trigger output units: unit 1 is set to 0x2 (indicates TOU3), at unit 2 is set to 0x0 (indicates TOU1) and at unit 3 is to set 0x1 (indicates TOU2).
9	0	RW	<b>Trigger Now</b> 1 = Immediately create the trigger output if the trigger target time is less than the system time clock. 0 = Wait for the trigger target time to occur to trigger the event output.

# KSZ8441HL/FHL

**TABLE 4-112: TRIGGER OUTPUT UNIT 1 CONFIGURATION AND CONTROL REGISTER 1 (0X228 – 0X229): TRIG1\_CFG\_1 (CONTINUED)**

Bit	Default	R/W	Description
8	0	RW	<b>Trigger Notify</b> 1 = Enable reporting both TRIG_DONE and TRIG_ERR status as well as interrupt to host if the interrupt enable bit is set in the TRIG_IE register. 0 = Disable reporting both TRIG_DONE and TRIG_ERR status.
7	0	RO	Reserved
6 - 4	000	RW	<b>Trigger Output Signal Pattern</b> This field is used to select the trigger output signal pattern when TRIG_EN = "1" and trigger target time has reached the system time: 000: TRIG_NEG_EDGE - Generates negative edge (from default "H" -> "L" and stays "L"). 001: TRIG_POS_EDGE - Generates positive edge (from default "L" -> "H" and stays "H"). 010: TRIG_NEG_PULSE - Generates negative pulse (from default "H" -> "L" pulse -> "H" and stays "H"). The pulse width is defined in TRIG1_CFG_2 register. 011: TRIG_POS_PULSE - Generates positive pulse (from default "L" -> "H" pulse -> "L" and stays "L"). The pulse width is defined in TRIG1_CFG_2 register. 100: TRIG_NEG_CYCLE - Generates negative periodic signal. The "L" pulse width is defined in TRIG1_CFG_2 register, the cycle width is defined in TRIG1_CFG_3/4 registers and the number of cycles is defined in TRIG1_CFG_5 register (it is an infinite number if this register value is zero). 101: TRIG_POS_CYCLE - Generates positive periodic signal. The "H" pulse width is defined in TRIG1_CFG_2 register, the cycle width is defined in TRIG1_CFG_3/4 registers and the number of cycles is defined in TRIG1_CFG_5 register (it is an infinite number if this register value is zero). 110: TRIG_REG_OUTPUT - Generates an output signal from a 16-bit register. This 16-bit register bit-pattern in TRIG1_CFG_6 is shifted LSB bit first and looped, each bit width is defined in TRIG1_CFG_3/4 registers and total number of bits to shift out is defined in TRIG1_CFG_5 register (it is an infinite number if this register value is zero). 111: Reserved Note: the maximum output clock frequency is up to 12.5 MHz.
3 - 0	0x0	RW	<b>Select GPIO[6:0] for This Trigger Output Unit</b> Associate one of the 7 GPIO pins to this trigger output unit. The trigger output signals are OR'ed together to form a combined signal if multiple trigger output units have selected the same GPIO output pin. 0x0 indicates GPIO0, and 0x6 indicates GPIO6. (0x7 to 0xF are not used.)



## 4.2.21.13 Trigger Output Unit 1 Configuration and Control Register 2 (0x22A – 0x22B): TRIG1\_CFG\_2

This register (2 of 8) contains the trigger output unit 1 configuration and control bits.

**TABLE 4-113: TRIGGER OUTPUT UNIT 1 CONFIGURATION AND CONTROL REGISTER 2 (0X22A – 0X22B): TRIG1\_CFG\_2**

Bit	Default	R/W	Description
15 - 0	0x0000	RW	<p><b>Trigger Output Pulse Width</b> This number defines the width of the generated pulse or periodic signal from this trigger output unit. Its unit value is equal to 8 ns. For example, the pulse width is 80 ns if this register value is 10 (0xA).</p> <p><b>Iteration Count</b> This number defines the iteration count for register trigger output pattern (TRIG1_CFG_6) in cascade mode when this trigger output unit is the tail unit. For example, 0x0000 = 1 count and 0x000F = 16 counts. It is an infinite number if there is no tail unit in Cascade mode.</p>

## 4.2.21.14 Trigger Output Unit 1 Configuration and Control Register 3 (0x22C – 0x22D): TRIG1\_CFG\_3

This register (3 of 8) contains the trigger output Unit 1 configuration and control bits.

**TABLE 4-114: TRIGGER OUTPUT UNIT 1 CONFIGURATION AND CONTROL REGISTER 3 (0X22C – 0X22D): TRIG1\_CFG\_3**

Bit	Default	R/W	Description
15 - 0	0x0000	RW	<p><b>Trigger Output Cycle Width or Bit Width Low-Word [15:0]</b> To define cycle width for generating periodic signal or to define each bit width in TRIG1_CFG_8. A unit number of value equals to 1 ns. For example, the cycle or bit width is 80 ns if this register value is 80 (0x50) and next register value = 0x0000.</p>

## 4.2.21.15 Trigger Output Unit 1 Configuration and Control Register 4 (0x22E – 0x22F): TRIG1\_CFG\_4

This register (4 of 8) contains the trigger output unit 1 configuration and control bits.

**TABLE 4-115: TRIGGER OUTPUT UNIT 1 CONFIGURATION AND CONTROL REGISTER 4 (0X22E – 0X22F): TRIG1\_CFG\_4**

Bit	Default	R/W	Description
15 - 0	0x0000	RW	<p><b>Trigger Output Cycle Width or Bit Width High-Word [31:16]</b> This number defines the cycle width when generating periodic signals using this trigger output unit. Also, it is used to define each bit width in TRIG1_CFG_8. Each unit is equal to 1 ns.</p>

## 4.2.21.16 Trigger Output Unit 1 Configuration and Control Register 5 (0x230 – 0x231): TRIG1\_CFG\_5

This register (5 of 8) contains the trigger output unit 1 configuration and control bits.

**TABLE 4-116: TRIGGER OUTPUT UNIT 1 CONFIGURATION AND CONTROL REGISTER 5 (0X230 – 0X231): TRIG1\_CFG\_5**

Bit	Default	R/W	Description
15 - 0	0x0000	RW	<p><b>Trigger Output Cycle Count</b> This number defines the quantity of cycles of the periodic signal output by the trigger output unit. Use a value of zero for infinite repetition. Valid for TRIG_NEG_CYCLE and TRIG_POS_CYCLE modes.</p> <p><b>Bit Count</b> This number can define the number of bits that are output when generating output signals from the bit pattern register. It is an infinite number if this register value is zero. Valid for TRIG_REG_OUTPUT mode.</p>

# KSZ8441HL/FHL

## 4.2.21.17 Trigger Output Unit 1 Configuration and Control Register 6 (0x232 – 0x233): TRIG1\_CFG\_6

This register (6 of 8) contains the trigger output unit 1 configuration and control bits.

**TABLE 4-117: TRIGGER OUTPUT UNIT 1 CONFIGURATION AND CONTROL REGISTER 6 (0X232 – 0X233): TRIG1\_CFG\_6**

Bit	Default	R/W	Description
15 - 0	0x0000	RW	<b>Trigger Output Unit Bit Pattern</b> This register is used to define the output bit pattern when the TRIG_REG_OUTPUT mode is selected. <b>Iteration Count</b> This register is used as the iteration count for the trigger output unit when the tail unit is in cascade mode but not using register mode. It is the number of cycles programmed in CFG_5 to be output by the trigger output unit. For example, 0x0000 = 1 count, 0x000F = 16 counts. An infinite number of cycles will occur if there is no tail unit in Cascade mode.

## 4.2.21.18 Trigger Output Unit 1 Configuration and Control Register 7 (0x234 – 0x235): TRIG1\_CFG\_7

This register (7 of 8) contains the trigger output unit 1 configuration and control bits.

**TABLE 4-118: TRIGGER OUTPUT UNIT 1 CONFIGURATION AND CONTROL REGISTER 7 (0X234 – 0X235): TRIG1\_CFG\_7**

Bit	Default	R/W	Description
15 - 0	0x0000	RW	<b>Trigger Output Iteration Cycle Time in Cascade Mode Low-Word [15:0]</b> The value in this pair of registers defines the iteration cycle time for the trigger output unit in cascade mode. This value will be added to the current trigger target time for establishing the next trigger time for the trigger output unit. A unit number of value equals to 1 ns. For example, the cycle is 800 ns if this register value is 800 (0x320) and next register value = 0x0000. The iteration count (CFG_6) × trigger output cycle count (CFG_5) × waveform cycle time must be less than the iteration cycle time specified in CFG_7 and CFG_8.

## 4.2.21.19 Trigger Output Unit 1 Configuration and Control Register 8 (0x236 – 0x237): TRIG1\_CFG\_8

This register (8 of 8) contains the trigger output unit 1 configuration and control bits.

**TABLE 4-119: TRIGGER OUTPUT UNIT 1 CONFIGURATION AND CONTROL REGISTER 8 (0X236 – 0X237): TRIG1\_CFG\_8**

Bit	Default	R/W	Description
15 - 0	0x0000	RW	<b>Trigger Output Iteration Cycle Time in Cascade Mode High-Word [31:16]</b> The value in this pair of registers defines the iteration cycle time for the trigger output unit in cascade mode. This value will be added to the current trigger target time for establishing the next trigger time for the trigger output unit. A unit number of value equals 1 ns.

## 4.2.21.20 0x238 – 0x23F: Reserved

## 4.2.21.21 Trigger Output Unit 2 Target Time and Output Configuration/Control Registers (0x240 – 0x257)

These 12 registers contain the trigger output unit 2 target time and configuration/control bits, TRIG2\_CFG\_[1:8]. See descriptions in [Section 4.2.21.8](#) through [Section 4.2.21.19](#). Note that there is one bit that is different in this set of register bits. It is indicated in the following text.

## 4.2.21.22 Trigger Output Unit 2 Configuration and Control Register 1 (0x248 – 0x249): TRIG2\_CFG\_1

This register contains the trigger output unit 2 configuration and control bits.

**TABLE 4-120: TRIGGER OUTPUT UNIT 2 CONFIGURATION AND CONTROL REGISTER 1 (0X248 – 0X249): TRIG2\_CFG\_1**

Bit	Default	R/W	Description
7	0	RW	<b>Trigger Unit 2 Clock Edge Output Select</b> This bit is used to select either the positive edge or negative edge of the 125 MHz to clock out the trigger unit 2 output. This bit only pertains to usage with GPIO1 pin. This bit will not function with any other GPIO pin. 1 = Use negative edge of 125 MHz clock to clock out data 0 = Use positive edge of 125 MHz clock to clock out data

4.2.21.23 0x258 – 0x25F: Reserved

## 4.2.21.24 Trigger Output Unit 3 Target Time and Output Configuration/Control Registers (0x260 – 0x277)

These 12 registers contain the trigger output unit 3 target time and configuration/control bits, TRIG3\_CFG\_[1:8]. See descriptions in [Section 4.2.21.8](#) through [Section 4.2.21.19](#).

4.2.21.25 0x278 – 0x27F: Reserved

## 4.2.21.26 Trigger Output Unit 4 Target Time and Output Configuration/Control Registers (0x280 – 0x297)

These 12 registers contain the trigger output unit 4 target time and configuration/control bits, TRIG4\_CFG\_[1:8]. See descriptions in [Section 4.2.21.8](#) through [Section 4.2.21.19](#).

4.2.21.27 0x298 – 0x29F: Reserved

## 4.2.21.28 Trigger Output Unit 5 Target Time and Output Configuration/Control Registers (0x2A0 – 0x2B7)

These 12 registers contain the trigger output unit 5 target time and configuration/control bits, TRIG5\_CFG\_[1:8]. See descriptions in [Section 4.2.21.8](#) through [Section 4.2.21.19](#).

4.2.21.29 0x2B8 – 0x2BF: Reserved

## 4.2.21.30 Trigger Output Unit 6 Target Time and Output Configuration/Control Registers (0x2C0 – 0x2D7)

These 12 registers contain the trigger output unit 6 target time and configuration/control bits, TRIG6\_CFG\_[1:8]. See descriptions in [Section 4.2.21.8](#) through [Section 4.2.21.19](#).

4.2.21.31 0x2D8 – 0x2DF: Reserved

## 4.2.21.32 Trigger Output Unit 7 Target Time and Output Configuration/Control Registers (0x2E0 – 0x2F7)

These 12 registers contain the trigger output unit 7 target time and configuration/control bits, TRIG7\_CFG\_[1:8]. See descriptions in [Section 4.2.21.8](#) through [Section 4.2.21.19](#).

4.2.21.33 0x2F8 – 0x2FF: Reserved

## 4.2.21.34 Trigger Output Unit 8 Target Time and Output Configuration/Control Registers (0x300 – 0x317)

These 12 registers contain the trigger output unit 8 target time and configuration/control bits, TRIG8\_CFG\_[1:8]. See descriptions in [Section 4.2.21.8](#) through [Section 4.2.21.19](#).

# KSZ8441HL/FHL

4.2.21.35 0x318 – 0x31F: Reserved

4.2.21.36 Trigger Output Unit 9 Target Time and Output Configuration/Control Registers (0x320 – 0x337)

These 12 registers contain the trigger output unit 9 target time and configuration/control bits, TRIG9\_CFG\_[1:8]. See descriptions in [Section 4.2.21.8](#) through [Section 4.2.21.19](#).

4.2.21.37 0x338 – 0x33F: Reserved

4.2.21.38 Trigger Output Unit 10 Target Time and Output Configuration/Control Registers (0x340 – 0x357)

These 12 registers contain the trigger output unit 10 target time and configuration/control bits, TRIG10\_CFG\_[1:8]. See descriptions in [Section 4.2.21.8](#) through [Section 4.2.21.19](#).

4.2.21.39 0x358 – 0x35F: Reserved

4.2.21.40 Trigger Output Unit 11 Target Time and Output Configuration/Control Registers (0x360 – 0x377)

These 12 registers contain the trigger output unit 11 target time and configuration/control bits, TRIG11\_CFG\_[1:8]. See descriptions in [Section 4.2.21.8](#) through [Section 4.2.21.19](#).

4.2.21.41 0x378 – 0x37F: Reserved

4.2.21.42 Trigger Output Unit 12 Target Time and Output Configuration/Control Registers (0x380 – 0x397)

These 12 registers contain the trigger output unit 12 target time and configuration/control bits, TRIG12\_CFG\_[1:8]. See descriptions in [Section 4.2.21.8](#) through [Section 4.2.21.19](#).

4.2.21.43 0x398 – 0x3FF: Reserved

4.2.22 INTERNAL I/O REGISTER SPACE MAPPING FOR PTP TIME STAMP INPUTS (12 UNITS, 0X400 – 0X5FF)

4.2.22.1 Time Stamp Ready Register (0x400 – 0x401): TS\_RDY

This register contains the PTP time stamp input unit ready-to-read status bits.

**TABLE 4-121: TIME STAMP READY REGISTER (0X400 – 0X401): TS\_RDY**

Bit	Default	R/W	Description
15 - 12	0x0	RO	Reserved
11 - 0	0x000	RO	<b>Time Stamp Input Unit Ready</b> 1 = This time stamp input unit is ready to read and will generate a time stamp interrupt if PTP_TS_IE = "1". This bit will clear when TS_EN is disabled. 0 = This time stamp input unit is not ready to read or disabled. There are 12 time stamp units and therefore there is a corresponding time stamp input ready bit for each of the time stamp units, bit[11:0] = unit[12:1].

4.2.22.2 Time Stamp Enable Register (0x402 – 0x403): TS\_EN

This register contains the PTP time stamp input unit enable control bits.

**TABLE 4-122: TIME STAMP ENABLE REGISTER (0X402 – 0X403): TS\_EN**

Bit	Default	R/W	Description
15 - 12	0x0	RO	Reserved

**TABLE 4-122: TIME STAMP ENABLE REGISTER (0X402 – 0X403): TS\_EN (CONTINUED)**

Bit	Default	R/W	Description
11 - 0	0x000	RO	<p><b>Time Stamp Input Unit Enable</b></p> <p>1 = Enable the selected time stamp input unit. Writing a “1” to this bit will clear the TS[12:1]_EVENT_DET_CNT.</p> <p>0 = Disable the selected time stamp input unit. Writing a “0” to this bit will clear the TS_RDY and TS[12:1]_DET_CNT_OVFL.</p> <p>There are 12 time stamp units and therefore there is a corresponding time stamp input unit enable bit for each of the time stamp units, bit[11:0] = unit[12:1].</p>

4.2.22.3 Time Stamp Software Reset Register (0x404 – 0x405): TS\_SW\_RST

This register contains the PTP time stamp input unit software reset control bits.

**TABLE 4-123: TIME STAMP SOFTWARE RESET REGISTER (0X404 – 0X405): TS\_SW\_RST**

Bit	Default	R/W	Description
15 - 12	0x0	RO	Reserved
11 - 0	0x000	RW/SC	<p><b>Time Stamp Input Unit Software Reset</b></p> <p>1 = Reset the selected time stamp input unit to inactive state and default setting.</p> <p>0 = The selected time stamp input unit is in normal mode of operation.</p> <p>There are 12 time stamp units and therefore there is a corresponding time stamp input unit software reset bit for each of the time stamp units, bit[11:0] = unit[12:1].</p>

4.2.22.4 0x406 – 0x41F: Reserved

4.2.22.5 Time Stamp Unit 1 Status Register (0x420 – 0x421): TS1\_STATUS

This register contains PTP time stamp input unit 1 status.

**TABLE 4-124: TIME STAMP UNIT 1 STATUS REGISTER (0X420 – 0X421): TS1\_STATUS**

Bit	Default	R/W	Description
15 - 4	0x000	RO	Reserved
4 - 1	0x0	RO	<p><b>Number of Detected Event Count for Time stamp Input Unit 1 (TS1_EVENT_DET_CNT)</b></p> <p>This field is used to report the number of detected events (either rising or falling edge) count. in single mode, it can detect up to 15 events in any single time stamp input unit. In cascade mode, it can detect up to two events in time stamp input units 1-11 or up to 8 events at time stamp input unit 12 as a non-tail unit, and it can detect up to 15 events for any time stamp input unit as a tail unit. Pulses or edges can be detected up to 25 MHz. The pulse width can be measured by the difference between consecutive time stamps in the same time stamp input unit.</p>
0	0	RO	<p><b>Number of Detected Event Count Overflow for Time stamp Input Unit 1 (TS1_DET_CNT_OVFL)</b></p> <p>1 = The number of detected event (either rising or falling edge) count has overflowed. In cascade mode, only tail unit will set this bit when overflow is occurred. The TS1_EVENT_DET_CNT will stay at 15 when overflow is occurred.</p> <p>0 = The number of events (either rising or falling edge) detected count has not overflowed.</p>

# KSZ8441HL/FHL

## 4.2.22.6 Time Stamp Unit 1 Configuration and Control Register (0x422 – 0x423): TS1\_CFG

This register contains PTP time stamp input unit 1 configuration and control bits.

**TABLE 4-125: TIME STAMP UNIT 1 CONFIGURATION AND CONTROL REGISTER (0X422 – 0X423): TS1\_CFG**

Bit	Default	R/W	Description
15 - 12	0x0	RO	Reserved
11 - 8	0x0	RW	<b>Select GPIO[6:0] for Time Stamp Unit 1</b> This field is used to select one of the 7 GPIO pins to serve this time stamp unit. It is GPIO0 if these bits = "0000" and it is GPIO6 if these bits = "0110" (from "0111" to "1111" are not used).
7	0	RW	<b>Enable Rising Edge Detection</b> 1 = Enable rising edge detection. 0 = Disable rising edge detection.
6	0	RW	<b>Enable Falling Edge Detection</b> 1 = Enable falling edge detection. 0 = Disable falling edge detection.
5	0	RW	<b>Select Tail Unit for this Time Stamp Unit in Cascade Mode</b> 1 = This time stamp unit is the last unit of the chain in cascade mode. 0 = This time stamp unit is not the last unit of the chain in cascade mode.
4 - 1	0x0	RW	<b>Select Upstream Time Stamp Done Unit in Cascade Mode</b> This is used to select one of the 12 upstream time stamps units for done input in cascade mode. For example, if units 1 (head unit), 2 and 3 (tail unit) are set up in cascade mode, then these 4-bits at unit 1 are set to 0x0, at unit 2 are set to 0x1, at unit 3 are set to 0x2.
0	0	RW	<b>Enable This Time Stamp Unit in Cascade Mode</b> 1 = Enable the selected time stamp input unit in Cascade mode. 0 = Disable the time stamp input unit in Cascade mode.

## 4.2.22.7 Time Stamp Unit 1 Input 1st Sample Time in Nanoseconds Low-Word Register (0x424 – 0x425): TS1\_SMPL1\_NSL

This register contains the first sample time in nanoseconds low-word (the resolution of 40 ns) for PTP time stamp unit 1.

**TABLE 4-126: TIME STAMP UNIT 1 INPUT 1ST SAMPLE TIME IN NANoseconds LOW-WORD REGISTER (0X424 – 0X425): TS1\_SMPL1\_NSL**

Bit	Default	R/W	Description
15 - 0	0x0000	RO	<b>1st Sample Time in ns Low-Word [15:0] Time Stamp Unit 1</b> This is the low-word of first sample time for time stamp unit 1 in nanoseconds.

## 4.2.22.8 Time Stamp Unit 1 Input 1st Sample Time in Nanoseconds High-Word Register (0x426 – 0x427): TS1\_SMPL1\_NSH

This register contains the first sample time in nanoseconds high-word and edge detection status for PTP time stamp unit 1.

**TABLE 4-127: TIME STAMP UNIT 1 INPUT 1ST SAMPLE TIME IN NANoseconds HIGH-WORD REGISTER (0X426 – 0X427): TS1\_SMPL1\_NSH**

Bit	Default	R/W	Description
15	0	RO	Reserved
14	0	RO	<b>1st Sample Edge Indication for Time Stamp Unit 1</b> 0 = Indicates the event is a falling edge signal. 1 = Indicates the event is a rising edge signal.

**TABLE 4-127: TIME STAMP UNIT 1 INPUT 1ST SAMPLE TIME IN NANoseconds HIGH-WORD REGISTER (0X426 – 0X427): TS1\_SMPL1\_NSH (CONTINUED)**

Bit	Default	R/W	Description
13 - 0	0x0000	RO	<b>1st Sample Time in ns High-Word [29:16] for Time Stamp Unit 1</b> This is the high-word of first sample time for time stamp unit 1 in nano-seconds.

4.2.22.9 Time Stamp Unit 1 Input 1st Sample Time in Seconds Low-Word Register (0x428 – 0x429): TS1\_SMPL1\_SL

This register contains the first sample time in seconds low-word for PTP time stamp unit 1.

**TABLE 4-128: TIME STAMP UNIT 1 INPUT 1ST SAMPLE TIME IN SECONDS LOW-WORD REGISTER (0X428 – 0X429): TS1\_SMPL1\_SL**

Bit	Default	R/W	Description
15 - 0	0x0000	RO	<b>1st Sample Time in Seconds Low-Word [15:0] for Time Stamp Unit 1</b> This is the low-word of first sample time for time stamp unit 1 in seconds.

4.2.22.10 Time Stamp Unit 1 Input 1st Sample Time in Seconds High-Word Register (0x42A – 0x42B): TS1\_SMPL1\_SH

This register contains the first sample time in seconds high-word for PTP time stamp unit 1.

**TABLE 4-129: TIME STAMP UNIT 1 INPUT 1ST SAMPLE TIME IN SECONDS HIGH-WORD REGISTER (0X42A – 0X42B): TS1\_SMPL1\_SH**

Bit	Default	R/W	Description
15 - 0	0x0000	RO	<b>1st Sample Time in Seconds High-Word [31:16] for Time Stamp Unit 1</b> This is the high-word of first sample time for time stamp unit 1 in seconds.

4.2.22.11 Time Stamp Unit 1 Input 1st Sample Time in Sub-Nanoseconds Register (0x42C – 0x42D): TS1\_SMPL1\_SUB\_NS

This register contains the first sample time in sub-8 nanoseconds (the resolution of 8 ns) for PTP time stamp unit 1.

**TABLE 4-130: TIME STAMP UNIT 1 INPUT 1ST SAMPLE TIME IN SUB-NANoseconds REGISTER (0X42C – 0X42D): TS1\_SMPL1\_SUB\_NS**

Bit	Default	R/W	Description
15 - 3	0x0000	RO	Reserved
2 - 0	000	RO	<b>1st Sample Time in Sub-8 Nanoseconds for Time stamp Unit 1</b> These bits indicate one of the 8 ns cycles for the first sample time for time stamp unit 1. 000: 0 ns (sample time at the first 8 ns cycle in 25 MHz/40 ns) 001: 8 ns (sample time at the second 8 ns cycle in 25 MHz/40 ns) 010: 16 ns (sample time at the third 8 ns cycle in 25 MHz/40 ns) 011: 24 ns (sample time at the fourth 8 ns cycle in 25 MHz/40 ns) 100: 32 ns (sample time at the fifth 8 ns cycle in 25 MHz/40 ns) 101-111: N/A

4.2.22.12 0x42E – 0x433: Reserved

# KSZ8441HL/FHL

## 4.2.22.13 Time Stamp Unit 1 Input 2nd Sample Time in Nanoseconds Low-Word Register (0x434 – 0x435): TS1\_SMPL2\_NSL

This register contains the second sample time in nanoseconds low-word (the resolution of 40 ns) for PTP time stamp Unit 1.

**TABLE 4-131: TIME STAMP UNIT 1 INPUT 2ND SAMPLE TIME IN NANOSECONDS LOW-WORD REGISTER (0X434 – 0X435): TS1\_SMPL2\_NSL**

Bit	Default	R/W	Description
15 - 0	0x0000	RO	<b>2nd Sample Time in Nanoseconds for Low-Word [15:0] for Time Stamp Unit 1</b> This is the low-word of the 2nd sample time for time stamp unit 1 in nanoseconds.

## 4.2.22.14 Time stamp Unit 1 Input 2nd Sample Time in Nanoseconds High-Word Register (0x436 – 0x437): TS1\_SMPL2\_NSH

This register contains the 2nd sample time in nanoseconds high-word and edge detection status for the PTP time stamp unit 1.

**TABLE 4-132: TIME STAMP UNIT 1 INPUT 2ND SAMPLE TIME IN NANOSECONDS HIGH-WORD REGISTER (0X436 – 0X437): TS1\_SMPL2\_NSH**

Bit	Default	R/W	Description
15	0	RO	Reserved
14	0	RO	<b>2nd Sample Edge Indication for Time Stamp Unit 1</b> 0 = Indicates the event is a falling edge signal. 1 = Indicates the event is a rising edge signal.
13 - 0	0x0000	RO	<b>2nd Sample Time in Nanoseconds High-Word [29:16] for Time Stamp Unit 1</b> This is the high-word of the 2nd sample time for time stamp unit 1 in nanoseconds.

## 4.2.22.15 Time Stamp Unit 1 Input 2nd Sample Time in Seconds Low-Word Register (0x438 – 0x439): TS1\_SMPL2\_SL

This register contains the 2nd sample time in seconds low-word for PTP time stamp unit 1.

**TABLE 4-133: TIME STAMP UNIT 1 INPUT 2ND SAMPLE TIME IN SECONDS LOW-WORD REGISTER (0X438 – 0X439): TS1\_SMPL2\_SL**

Bit	Default	R/W	Description
15 - 0	0x0000	RO	<b>2nd Sample Time in Seconds Low-Word [15:0] for Time Stamp Unit 1</b> This is the low-word of the second sample time for time stamp unit 1 in seconds.

## 4.2.22.16 Time Stamp Unit 1 Input 2nd Sample Time in Seconds High-Word Register (0x43A – 0x43B): TS1\_SMPL2\_SH

This register contains the 2nd sample time in seconds high-word for PTP time stamp unit 1.

**TABLE 4-134: TIME STAMP UNIT 1 INPUT 2ND SAMPLE TIME IN SECONDS HIGH-WORD REGISTER (0X43A – 0X43B): TS1\_SMPL2\_SH**

Bit	Default	R/W	Description
15 - 0	0x0000	RO	<b>2nd Sample Time in Seconds High-Word [31:16] for Time Stamp Unit 1</b> This is the high-word of the second sample time for time stamp unit 1 in seconds.



## 4.2.22.17 Time Stamp Unit 1 Input 2nd Sample Time in Sub-Nanoseconds Register (0x43C – 0x43D): TS1\_SMPL2\_SUB\_NS

This register contains the 2nd sample time in sub-8 nanoseconds (the resolution of 8 ns) for PTP time stamp unit 1.

**TABLE 4-135: TIME STAMP UNIT 1 INPUT 2ND SAMPLE TIME IN SUB-NANOSECONDS REGISTER (0X43C – 0X43D): TS1\_SMPL2\_SUB\_NS**

Bit	Default	R/W	Description
15 - 3	0x0000	RO	Reserved
2 - 0	000	RO	<b>2nd Sample Time in Sub-8 Nanoseconds for Time Stamp Unit 1</b> These bits indicate one of the 8 ns cycle for the second sample time for time stamp unit 1. 000: 0 ns (sample time at the first 8 ns cycle in 25 MHz/40 ns) 001: 8 ns (sample time at the second 8 ns cycle in 25 MHz/40 ns) 010: 16 ns (sample time at the third 8 ns cycle in 25 MHz/40 ns) 011: 24 ns (sample time at the fourth 8 ns cycle in 25 MHz/40 ns) 100: 32 ns (sample time at the fifth 8 ns cycle in 25 MHz/40 ns) 101-111: N/A

4.2.22.18 0x43E – 0x43F: Reserved

## 4.2.22.19 Time Stamp Unit 2 Status/Configuration/Control and Input 1st Sample Time Registers (0x440 – 0x44D)

These seven registers contain the first sample time and status/configuration/control information for PTP time stamp unit 2. See description in time stamp unit 1 (0x420 – 0x42D).

4.2.22.20 0x44E – 0x453: Reserved

## 4.2.22.21 Time Stamp Unit 2 Input 2nd Sample Time Registers (0x454 – 0x45D)

These five registers contain the second sample time for PTP time stamp unit 2. See description in time stamp unit 1 (0x434 – 0x43D).

4.2.22.22 0x45E – 0x45F: Reserved

## 4.2.22.23 Time Stamp Unit 3 Status/Configuration/Control and Input 1st Sample Time Registers (0x460 – 0x46D)

These seven registers contain the first sample time and status/configuration/control information for PTP time stamp unit 3. See description in time stamp unit 1 (0x420 – 0x42D).

4.2.22.24 0x46E – 0x473: Reserved

## 4.2.22.25 Time Stamp Unit 3 Input 2nd Sample Time Registers (0x474 – 0x47D)

These five registers contain the 2nd sample time for PTP time stamp unit 3. See description in time stamp unit 1 (0x434 – 0x43D).

4.2.22.26 0x47E – 0x47F: Reserved

## 4.2.22.27 Time Stamp Unit 4 Status/Configuration/Control and Input 1st Sample Time Registers (0x480 – 0x48D)

These seven registers contain the 1st sample time and status/configuration/control information for PTP time stamp unit 4. See description in time stamp unit 1 (0x420 – 0x42D).

4.2.22.28 0x48E – 0x493: Reserved

## 4.2.22.29 Time Stamp Unit 4 Input 2nd Sample Time Registers (0x494 – 0x49D)

These five registers contain the 2nd sample time for PTP time stamp unit 4 input. See description in time stamp unit 1 (0x434 – 0x43D).

# KSZ8441HL/FHL

---

4.2.22.30 0x49E – 0x49F: Reserved

4.2.22.31 Time Stamp Unit 5 Status/Configuration/Control and Input 1st Sample Time Registers (0x4A0 – 0x4AD)

These seven registers contain the 1st sample time and status/configuration/control information for PTP time stamp unit 5. See description in time stamp unit 1 (0x420 – 0x42D).

4.2.22.32 0x4AE – 0x4B3: Reserved

4.2.22.33 Time Stamp Unit 5 Input 2nd Sample Time Registers (0x4B4 – 0x4BD)

These five registers contain the 2nd sample time for PTP time stamp unit 5. See description in time stamp unit 1 (0x434 – 0x43D).

4.2.22.34 0x4BE – 0x4BF: Reserved

4.2.22.35 Time Stamp Unit 6 Status/Configuration/Control and Input 1st Sample Time Registers (0x4C0 – 0x4CD)

These seven registers contain the 1st sample time and status/configuration/control information for PTP time stamp unit 6. See description in time stamp unit 1 (0x420 – 0x42D).

4.2.22.36 0x4CE – 0x4D3: Reserved

4.2.22.37 Time Stamp Unit 6 Input 2nd Sample Time Registers (0x4D4 – 0x4DD)

These five registers contain the 2nd sample time for PTP time stamp unit 6. See description in time stamp unit 1 (0x434 – 0x43D).

4.2.22.38 0x4DE – 0x4DF: Reserved

4.2.22.39 Time Stamp Unit 7 Status/Configuration/Control and Input 1st Sample Time Registers (0x4E0 – 0x4ED)

These seven registers contain the 1st sample time and status/configuration/control information for PTP time stamp unit 7. See description in time stamp unit 1 (0x420 – 0x42D).

4.2.22.40 0x4EE – 0x4F3: Reserved

4.2.22.41 Time Stamp Unit 7 Input 2nd Sample Time Registers (0x4F4 – 0x4FD)

These five registers contain the 2nd sample time for PTP time stamp unit 7. See description in time stamp unit 1 (0x434 – 0x43D).

4.2.22.42 0x4FE – 0x4FF: Reserved

4.2.22.43 Time Stamp Unit 8 Status/Configuration/Control and Input 1st Sample Time Registers (0x500 – 0x50D)

These seven registers contain the 1st sample time and status/configuration/control information for PTP time stamp unit 8. See description in time stamp unit 1 (0x420 – 0x42D).

4.2.22.44 0x50E – 0x513: Reserved

4.2.22.45 Time Stamp Unit 8 Input 2nd Sample Time Registers (0x514 – 0x51D)

These five registers contain the 2nd sample time for PTP time stamp unit 8. See description in time stamp unit 1 (0x434 – 0x43D).

4.2.22.46 0x51E – 0x51F: Reserved

4.2.22.47 Time Stamp Unit 9 Status/Configuration/Control and Input 1st Sample Time Registers (0x520 – 0x52D)

These seven registers contain the 1st sample time and status/configuration/control information for PTP time stamp unit 9. See description in time stamp unit 1 (0x420 – 0x42D).

4.2.22.48 0x52E – 0x533: Reserved

4.2.22.49 Time Stamp Unit 9 Input 2nd Sample Time Registers (0x534 – 0x53D)

These five registers contain the 2nd sample time for PTP time stamp unit 9. See description in time stamp unit 1 (0x434 – 0x43D).

4.2.22.50 0x53E – 0x53F: Reserved

4.2.22.51 Time Stamp Unit 10 Status/Configuration/Control and Input 1st Sample Time Registers (0x540 – 0x54D)

These seven registers contain the 1st sample time and status/configuration/control information for PTP time stamp unit 10. See description in time stamp unit 1 (0x420 – 0x42D).

4.2.22.52 0x54E – 0x553: Reserved

4.2.22.53 Time Stamp Unit 10 Input 2nd Sample Time Registers (0x554 – 0x55D)

These five registers contain the 2nd sample time for PTP time stamp unit 10. See description in time stamp unit 1 (0x434 – 0x43D).

4.2.22.54 0x55E – 0x55F: Reserved

4.2.22.55 Time Stamp Unit 11 Status/Configuration/Control and Input 1st Sample Time Registers (0x560 – 0x56D)

These seven registers contain the 1st sample time and status/configuration/control information for PTP time stamp unit 11. See description in time stamp unit 1 (0x420 – 0x42D).

4.2.22.56 0x56E – 0x573: Reserved

4.2.22.57 Time Stamp Unit 11 Input 2nd Sample Time Registers (0x574 – 0x57D)

These five registers contain the 2nd sample time for PTP time stamp unit 11. See description in time stamp unit 1 (0x434 – 0x43D).

4.2.22.58 0x57E – 0x57F: Reserved

4.2.22.59 Time Stamp Unit 12 Status/Configuration/Control and Input 1st Sample Time Registers (0x580 – 0x58D)

Please note that time stamp unit 12 has eight sample time registers available.

These seven registers contain the 1st sample time and status/configuration/control information for PTP time stamp unit 12. See description in time stamp unit 1 (0x420 – 0x42D).

4.2.22.60 0x58E – 0x593: Reserved

4.2.22.61 Time Stamp Unit 12 Input 2nd Sample Time Registers (0x594 – 0x59D)

These 5 registers contain the 2nd sample time for PTP time stamp unit 12. See description in time stamp unit 1 (0x434 – 0x43D).

# KSZ8441HL/FHL

4.2.22.62 0x59E – 0x5A3: Reserved

4.2.22.63 Time Stamp Unit 12 Input 3rd Sample Time Registers (0x5A4 – 0x5AD)

These 5 registers contain the 3rd sample time for PTP time stamp unit 12. See description in time stamp unit 1 (0x434 – 0x43D).

4.2.22.64 0x5AE – 0x5B3: Reserved

4.2.22.65 Time Stamp Unit 12 Input 4th Sample Time Registers (0x5B4 – 0x5BD)

These five registers contain the 4th sample time for PTP time stamp unit 12. See description in time stamp unit 1 (0x434 – 0x43D).

4.2.22.66 0x5BE – 0x5C3: Reserved

4.2.22.67 Time Stamp Unit 12 Input 5th Sample Time Registers (0x5C4 – 0x5CD)

These five registers contain the 5th sample time for PTP time stamp unit 12. See description in time stamp unit 1 (0x434 – 0x43D).

4.2.22.68 0x5CE – 0x5D3: Reserved

4.2.22.69 Time Stamp Unit 12 Input 6th Sample Time Registers (0x5D4 – 0x5DD)

These five registers contain the 6th sample time for PTP time stamp unit 12. See description in time stamp unit 1 (0x434 – 0x43D).

4.2.22.70 0x5DE – 0x5E3: Reserved

4.2.22.71 Time Stamp Unit 12 Input 7th Sample Time Registers (0x5E4 – 0x5ED)

These five registers contain the 7th sample time for PTP time stamp unit 12. See description in time stamp unit 1 (0x434 – 0x43D).

4.2.22.72 0x5EE – 0x5F3: Reserved

4.2.22.73 Time stamp Unit 12 Input 8th Sample Time Registers (0x5F4 – 0x5FD)

These five registers contain the 8th sample time for PTP time stamp unit 12. See description in time stamp unit 1 (0x434 – 0x43D).

4.2.22.74 0x5FE – 0x5FF: Reserved

4.2.23 INTERNAL I/O REGISTERS SPACE MAPPING FOR PTP 1588 CLOCK AND GLOBAL CONTROL (0X600 – 0X7FF)

4.2.23.1 PTP Clock Control Register (0x600 – 0x601): PTP\_CLK\_CTL

This register contains control of PTP 1588 clock.

**TABLE 4-136: PTP CLOCK CONTROL REGISTER (0X600 – 0X601): PTP\_CLK\_CTL**

Bit	Default	R/W	Description
15 - 7	0x000	RO	Reserved
6	0	RW/SC	<b>Enable Step Adjustment Mode to PTP 1588 Clock (PTP_STEP_ADJ_CLK)</b> Setting this bit will cause the time value in PTP_RTC_NSH/L registers to be added (PTP_STEP_DIR, bit [5]= “1” or subtracted (PTP_STEP_DIR, bit [5] = “0”) from the system time clock. This bit is self-clearing.

**TABLE 4-136: PTP CLOCK CONTROL REGISTER (0X600 – 0X601): PTP\_CLK\_CTL (CONTINUED)**

Bit	Default	R/W	Description
5	0	RW	<b>Direction Control for Step Adjustment Mode (PTP_STEP_DIR)</b> 1 = To add the time value in PTP_RTC_NSH/L registers to system time clock. 0 = To subtract the time value in PTP_RTC_NSH/L registers from system time clock.
4	0	RW/SC	<b>Enable Read PTP 1588 Clock (PTP_READ_CLK)</b> Setting this bit will cause the device to sample the PTP 1588 clock time value. This time value will be made available for reading through the PTP_RTC_SH/L, PTP_RTC_NSH/L and PTP_RTC_PHASE registers. This bit is self-clearing.
3	0	RW/SC	<b>Enable Load PTP 1588 Clock for Direct Time Setting Mode (PTP_LOAD_CLK)</b> Setting this bit will cause the device to load the PTP 1588 clock time value from PTP_RTC_SH/L, PTP_RTC_NSH/L and PTP_RTC_PHASE registers. The writes to PTP_RTC_SH/L, PTP_RTC_NSH/L and PTP_RTC_PHASE are performed before setting this bit. This bit is self-clearing.
2	0	RW	<b>Enable Continuous Adjustment Mode for PTP 1588 Clock (PTP_CONTINU_ADJ_CLK)</b> 1 = Enable continuous incrementing (PTP_RATE_DIR = "0") or decrementing (PTP_RATE_DIR = "1") frequency adjustment by the value in PTP_SNS_RATE_H [29:16] and PTP_SNS_RATE_L [15:0] on every 25 MHz clock cycle. 0 = Disable continuous adjustment mode to PTP 1588 clock.
1	1	RW	<b>Enable PTP 1588 Clock (EN_PTP_CLK)</b> 1 = To enable the PTP clock. 0 = To disable the PTP clock and the PTP clock will be frozen. For non-PTP mode, this bit is set to "0" for stopping clock toggling.
0	0	RW/SC	<b>Reset PTP 1588 Clock (RESET_PTP_CLK)</b> Setting this bit will reset the PTP 1588 clock.

4.2.23.2 0x602 – 0x603: Reserved

4.2.23.3 PTP Real Time Clock in Nanoseconds Low-Word Register (0x604 – 0x605): PTP\_RTC\_NSL  
This register contains the PTP real time clock in nanoseconds low-word.

**TABLE 4-137: PTP REAL TIME CLOCK IN NANoseconds LOW-WORD REGISTER (0X604 – 0X605): PTP\_RTC\_NSL**

Bit	Default	R/W	Description
15 - 0	0x0000	RW	<b>PTP Real Time Clock in Nanoseconds Low-Word [15:0]</b> This is low-word of the PTP real time clock in nanoseconds.

4.2.23.4 PTP Real Time Clock in Nanoseconds High-Word Register (0x606 – 0x607): PTP\_RTC\_NSH  
This register contains the PTP real time clock in nanoseconds high-word.

**TABLE 4-138: PTP REAL TIME CLOCK IN NANoseconds HIGH-WORD REGISTER (0X606 – 0X607): PTP\_RTC\_NSH**

Bit	Default	R/W	Description
15 - 14	00	RW	Upper two bits in counter not used.

# KSZ8441HL/FHL

**TABLE 4-138: PTP REAL TIME CLOCK IN NANOSECONDS HIGH-WORD REGISTER (0X606 – 0X607): PTP\_RTC\_NSH (CONTINUED)**

Bit	Default	R/W	Description
13 - 0	0x0000	RW	<b>PTP Real Time Clock in Nanoseconds High-Word [29:16]</b> This is high-word of the PTP real time clock in nanoseconds.

4.2.23.5 PTP Real Time Clock in Seconds Low-Word Register (0x608 – 0x609): PTP\_RTC\_SL  
This register contains the PTP real time clock in seconds low-word.

**TABLE 4-139: PTP REAL TIME CLOCK IN SECONDS LOW-WORD REGISTER (0X608 – 0X609): PTP\_RTC\_SL**

Bit	Default	R/W	Description
15 - 0	0x0000	RW	<b>PTP Real Time Clock in Seconds Low-Word [15:0]</b> This is low-word of the PTP real time clock in seconds.

4.2.23.6 PTP Real Time Clock in Seconds High-Word Register (0x60A – 0x60B): PTP\_RTC\_SH  
This register contains the PTP real time clock in seconds high-word.

**TABLE 4-140: PTP REAL TIME CLOCK IN SECONDS HIGH-WORD REGISTER (0X60A – 0X60B): PTP\_RTC\_SH**

Bit	Default	R/W	Description
15 - 0	0x0000	RW	<b>PTP Real Time Clock in Seconds High-Word [31:16]</b> This is high-word of the PTP real time clock in seconds.

4.2.23.7 PTP Real Time Clock in Phase Register (0x60C – 0x60D): PTP\_RTC\_PHASE  
This register indicates which sub-phase of the PTP real time clock is current. The resolution is 8 ns. The PTP real time clock is updated every 40 ns.

**TABLE 4-141: PTP REAL TIME CLOCK IN PHASE REGISTER (0X60C – 0X60D): PTP\_RTC\_PHASE**

Bit	Default	R/W	Description
15 - 3	0x0000	RO	Reserved
2 - 0	000	RW	<b>PTP Real Time Clock in Sub 8ns Phase</b> These bits indicate one of the 8ns sub-cycle times of the 40 ns period PTP real time clock. 000: 0 ns (real time clock at the first 8 ns cycle in 25 MHz/40 ns) 001: 8 ns (real time clock at the second 8 ns cycle in 25 MHz/40 ns) 010: 16 ns (real time clock at the third 8 ns cycle in 25 MHz/40 ns) 011: 24 ns (real time clock at the fourth 8 ns cycle in 25 MHz/40 ns) 100: 32 ns (real time clock at the fifth 8 ns cycle in 25 MHz/40 ns) 101-111: N/A This register is set to zero whenever the PTP_RTC_NSL, PTP_RTC_NSH, PTP_RTC_SL, PTP_RTC_SH registers are written to by the CPU.

4.2.23.8 0x60E – 0x60F: Reserved

#### 4.2.23.9 PTP Rate in Sub-Nanoseconds Low-Word Register (0x610 – 0x611): PTP\_SNS\_RATE\_L

This register contains the PTP rate control in sub-nanoseconds low-word.

**TABLE 4-142: PTP RATE IN SUB-NANOSECONDS LOW-WORD REGISTER (0X610 – 0X611): PTP\_SNS\_RATE\_L**

Bit	Default	R/W	Description
15 - 0	0x0000	RW	<b>PTP Rate Control in Sub-Nanoseconds Low-Word [15:0]</b> This is low-word of PTP rate control value in units of $2^{-32}$ ns. The PTP rate control value is used for incrementing (PTP_RATE_DIR = "0") or decrementing (PTP_RATE_DIR = "1") the frequency adjustment by the value in PTP_SNS_RATE_H [29:16] and PTP_SNS_RATE_L [15:0] per reference clock cycle (40 ns). On each reference clock cycle, the PTP clock will be adjusted REF_CLK_PERIOD $\pm$ PTP_SNS_RATE_H/L value. Setting both PTP_SNS_RATE_H/L registers value to "0x0" will disable both continuous and temporary adjustment modes.

#### 4.2.23.10 PTP Rate in Sub-Nanoseconds High-Word and Control Register (0x612 – 0x613): PTP\_SNS\_RATE\_H

This register contains the PTP rate control in sub-nanoseconds high-word and configuration.

**TABLE 4-143: PTP RATE IN SUB-NANOSECONDS HIGH-WORD AND CONTROL REGISTER (0X612 – 0X613): PTP\_SNS\_RATE\_H**

Bit	Default	R/W	Description
15	0	RW	<b>Rate Direction Control for Temporary or Continuous Adjustment Mode (PTP_RATE_DIR)</b> 1 = Lower frequency. The PTP_SNS_RATE_H/L value will be added to system time clock on every 25 MHz clock cycle. 0 = Higher frequency. The PTP_SNS_RATE_H/L value will be subtracted from system time clock on every 25 MHz clock cycle.
14	0	RW/SC	<b>Enable Temporary Adjustment Mode for PTP 1588 Clock (PTP_TEMP_ADJ_CLK)</b> 1 = Enable the temporary incrementing (PTP_RATE_DIR = "0") or decrementing (PTP_RATE_DIR = "1") frequency adjustment by the value in the PTP_SNS_RATE_H/L registers over the duration of time set in the PTP_ADJ_DURA_H/L registers on every 25 MHz clock cycle. This bit is self-cleared when the adjustment is completed. Software can read this bit to check whether the adjustment is still in progress. 0 = Disable the temporary adjustment mode to the PTP clock.
13 - 0	0x0000	RW	<b>PTP Rate Control in Sub-Nanoseconds High-Word [29:16] (PTP_SNS_RATE_H[29:16])</b> This is high-word of PTP rate control value in units of $2^{-32}$ ns. The PTP rate control value is used for incrementing (PTP_RATE_DIR = "0") or decrementing (PTP_RATE_DIR = "1") the frequency adjustment by the value in PTP_SNS_RATE_H [29:16] and PTP_SNS_RATE_L [15:0] per reference clock cycle (40 ns). On each reference clock cycle, the PTP clock will be adjusted by a REF_CLK_PERIOD $\pm$ PTP_SNS_RATE_H/L value. Setting both PTP_SNS_RATE_H/L registers value to "0x0" will disable both continuous and temporary adjustment modes.

# KSZ8441HL/FHL

## 4.2.23.11 PTP Temporary Adjustment Mode Duration in Low-Word Register (0x614 – 0x615): PTP\_TEMP\_ADJ\_DURA\_L

This register contains the PTP temporary rate adjustment duration in low-word.

**TABLE 4-144: PTP TEMPORARY ADJUSTMENT MODE DURATION IN LOW-WORD REGISTER (0X614 – 0X615): PTP\_TEMP\_ADJ\_DURA\_L**

Bit	Default	R/W	Description
15 - 0	0x0000	RW	<b>PTP Temporary Rate Adjustment Duration in Low-Word [15:0]</b> This register is used to set the duration for the temporary rate adjustment in number of 25 MHz clock cycles.

## 4.2.23.12 PTP Temporary Adjustment Mode Duration in High-Word Register (0x616 – 0x617): PTP\_TEMP\_ADJ\_DURA\_H

This register contains the PTP temporary rate adjustment duration in high-word.

**TABLE 4-145: PTP TEMPORARY ADJUSTMENT MODE DURATION IN HIGH-WORD REGISTER (0X616 – 0X617): PTP\_TEMP\_ADJ\_DURA\_H**

Bit	Default	R/W	Description
15 - 0	0x0000	RW	<b>PTP Temporary Rate Adjustment Duration in High-Word [31:16]</b> This register is used to set the duration for the temporary rate adjustment in number of 25 MHz clock cycles.

## 4.2.23.13 0x618 – 0x61F: Reserved

## 4.2.23.14 PTP Message Configuration 1 Register (0x620 – 0x621): PTP\_MSG\_CFG\_1

This register contains the PTP message configuration 1.

**TABLE 4-146: PTP MESSAGE CONFIGURATION 1 REGISTER (0X620 – 0X621): PTP\_MSG\_CFG\_1**

Bit	Default	R/W	Description
15 - 8	0x00	RO	Reserved
7	0	RW	Reserved
6	1	RW	<b>Enable IEEE 1588 PTP Mode</b> 1 = To enable the IEEE 1588 PTP mode. 0 = To disable the IEEE 1588 PTP mode.
5	0	RW	<b>Enable Detection of IEEE 802.3 Ethernet PTP Message</b> 1 = Enable to detect the Ethernet PTP message. 0 = Disable to detect the Ethernet PTP message.
4	1	RW	<b>Enable Detection of IPv4/UDP PTP Message</b> 1 = Enable to detect the IPv4/UDP PTP message. 0 = Disable to detect the IPv4/UDP PTP message.
3	1	RW	<b>Enable Detection of IPv6/UDP PTP Message</b> 1 = Enable to detect the IPv6/UDP PTP message. 0 = Disable to detect the IPv6/UDP PTP message.
2	0	RW	<b>Selection of P2P or E2E</b> 1 = Select Peer-to-Peer (P2P) transparent clock mode. 0 = Select End-to-End (E2E) transparent clock mode.
1	0	RW	<b>Selection of Master or Slave</b> 1 = Select port 3 as master in ordinary clock mode. 0 = Select port 3 as slave in ordinary clock mode.
0	1	RW	<b>Selection of One-step or Two-Step Operation</b> 1 = Select one-step clock mode. 0 = Select two-step clock mode.



## 4.2.23.15 PTP Message Configuration 2 Register (0x622 – 0x623): PTP\_MSG\_CFG\_2

This register contains the PTP message configuration 2.

**TABLE 4-147: PTP MESSAGE CONFIGURATION 2 REGISTER (0X622 – 0X623): PTP\_MSG\_CFG\_2**

Bit	Default	R/W	Description
15 - 13	000	RO	Reserved
12	0	RW	<p><b>Enable Unicast PTP</b>            1 = The Unicast PTP packet can be recognized. If the packet UDP destination port is either 319 or 320 and the packet MAC/IP address is not the PTP reserved address, then the packet will be considered as Unicast PTP packet and the packet forwarding will be decided by regular table lookup.            0 = Only multicast PTP packet will be recognized.</p>
11	0	RW	<p><b>Enable Alternate Master</b>            1 = Alternate master clock is supported. The Sync, Follow_Up, Delay_Req, and Delay_Resp messages of the same domain received at Port 1 by active master clock of same domain will be forwarded to the host port.            0 = Alternate master clock is not supported. The Sync message of the same domain will be dropped if the host port is connected to a Master. The Delay_Req message of same domain received at Port 1 by active master clock of same domain will be forwarded to the Host Port. This bit is only meaningful when the host port is connected to a Master.</p>
10	1	RW	<p><b>PTP Messages Priority TX Queue</b>            1 = All PTP messages are assigned to highest priority TX queue.            0 = Only the PTP event messages are assigned to highest priority TX queue.</p>
9	0	RW	<p><b>Enable Checking of Associated Sync and Follow_Up PTP Messages</b>            Setting this bit will associate Follow_Up message with Sync message under certain situations. Refer to the 1588 PTP Developers Guide document for detailed information on its usage.</p>
8	0	RW	<p><b>Enable Checking of Associated Delay_Req and Delay_Resp PTP Messages</b>            While this bit is set, the Delay_Resp message will be dropped if the associations do not match and is forwarded to the host port if the associations match. Setting this bit will associate Delay_Resp message with Delay_Req message when it has the same domain, sequenceID, and sourcePortID. The PTP frame will be forwarded to the Host Port if the ID matches.</p>
7	0	RW	<p><b>Enable Checking of Associated Pdelay_Req and Pdelay_Resp PTP Messages</b>            While this bit is set, the Pdelay_Resp message will be dropped if the associations do not match and is forwarded to the Host Port if the associations match. Setting this bit will associate Pdelay_Resp/Pdelay_Resp_Follow_Up messages with Pdelay_Req message when it is has the same domain, sequenceID, and sourcePortID. The PTP frame will be forwarded to the host port if the ID matches. This bit only applies to PTP frames on the host port.</p>
6	0	RO	Reserved
5	0	RW	Reserved

# KSZ8441HL/FHL

**TABLE 4-147: PTP MESSAGE CONFIGURATION 2 REGISTER (0X622 – 0X623): PTP\_MSG\_CFG\_2 (CONTINUED)**

Bit	Default	R/W	Description
4	0	RW	<b>Enable Checking of Domain Field: DOMAIN_EN</b> Setting this DOMAIN_EN bit will enable the device to automatically check the domain field in PTP message with the PTP_DOMAIN_VER[7:0]. The PTP message will be forwarded to the Host Port if the domain field is matched to PTP_DOMAIN_VER[7:0] otherwise the PTP message will be dropped. If set this bit to “0”, regardless of domain field, the PTP messages are forwarded to the Host Port according to hardware default rules.
3	0	RO	Reserved
2	1	RW	<b>Enable the IPv4/UDP Checksum Calculation for Egress Packets</b> 1 = The device will re-calculate and generate a 2-byte checksum value due to a frame contents change. 0 = The checksum field is set to zero. If the IPv4/UDP checksum is zero, the checksum will remain zero regardless of this bit setting. For IPv6/UDP, the checksum is always updated.
1	0	RW	<b>Announce Message from Port 1</b> 1 = The Announce message is received from port 1 direction. 0 = The Announce message is not received from port 1 direction.
0	0	RW	Reserved

#### 4.2.23.16 PTP Domain and Version Register (0x624 – 0x625): PTP\_DOMAIN\_VER

This register contains the PTP Domain and Version Information.

**TABLE 4-148: PTP DOMAIN AND VERSION REGISTER (0X624 – 0X625): PTP\_DOMAIN\_VER**

Bit	Default	R/W	Description
15 - 12	0x0	RO	Reserved
11 - 8	0x2	RW	<b>PTP Version</b> This is the value of PTP message version number field. All PTP packets will be captured when the receive PTP message version matches the value in this field. All PTP packets will be dropped if the receive PTP message version does not match the value in this field.
7 - 0	0x00	RW	<b>PTP Domain</b> This is the value of PTP message domain number field. If the DOMAIN_EN bit is set to “1”, the PTP messages will be filtered out and only forwarded to the Host Port if the domain number matches. If the DOMAIN_EN bit is set to “0”, the domain number field will be ignored under certain circumstances.

#### 4.2.23.17 0x626 – 0x63F: Reserved

#### 4.2.23.18 PTP Port 1 Receive Latency Register (0x640 – 0x641): PTP\_P1\_RX\_LATENCY

This register contains the PTP port 1 receive latency value in nanoseconds.

**TABLE 4-149: PTP PORT 1 RECEIVE LATENCY REGISTER (0X640 – 0X641): PTP\_P1\_RX\_LATENCY**

Bit	Default	R/W	Description
15 - 0	0x019F	RW	<b>PTP Port 1 RX Latency in Nanoseconds [15:0]</b> This register is used to set the fixed receive delay value from port 1 wire to RX time stamp reference point. The default value is 415 ns.

## 4.2.23.19 PTP Port 1 Transmit Latency Register (0x642 – 0x643): PTP\_P1\_TX\_LATENCY

This register contains the PTP port 1 transmit latency value in nanoseconds.

**TABLE 4-150: PTP PORT 1 TRANSMIT LATENCY REGISTER (0X642 – 0X643): PTP\_P1\_TX\_LATENCY**

Bit	Default	R/W	Description
15 - 0	0x002D	RW	<b>PTP Port 1 TX Latency in Nanoseconds [15:0]</b> This register is used to set the fixed transmit delay value from port 1 TX time stamp reference point to wire. The default value is 45 ns.

## 4.2.23.20 PTP Port 1 Asymmetry Correction Register (0x644 – 0x645): PTP\_P1\_ASYM\_COR

This register contains the PTP port 1 asymmetry correction value in nanoseconds.

**TABLE 4-151: PTP PORT 1 ASYMMETRY CORRECTION REGISTER (0X644 – 0X645): PTP\_P1\_ASYM\_COR**

Bit	Default	R/W	Description
15	0	RW	<b>PTP Port 1 Asymmetry Correction Sign Bit</b> 1 = The magnitude in bit[14:0] is negative. 0 = The magnitude in bit[14:0] is positive.
14 - 0	0x0000	RW	<b>PTP Port 1 Asymmetry Correction in Nanoseconds [14:0]</b> This register is used to set the fixed asymmetry value to add in the correction field for ingress Sync and Pdelay_Resp or to subtract from correction field for egress Delay_Req and Pdelay_Req.

## 4.2.23.21 PTP Port 1 Link Delay Register (0x646 – 0x647): PTP\_P1\_LINK\_DLY

This register contains the PTP port 1 link delay in nanoseconds.

**TABLE 4-152: PTP PORT 1 LINK DELAY REGISTER (0X646 – 0X647): PTP\_P1\_LINK\_DLY**

Bit	Default	R/W	Description
15 - 0	0x0000	RW	<b>PTP Port 1 Link Delay in Nanoseconds [15:0]</b> This register is used to set the link delay value between port 1 and link partner port.

## 4.2.23.22 PTP Port 1 Egress Time Stamp Low-Word Register for Pdelay\_Req and Delay\_Req (0x648 – 0x649): P1\_XDLY\_REQ\_TSL

This register contains the PTP port 1 egress time stamp low-word value for Pdelay\_Req and Delay\_Req frames in nanoseconds.

**TABLE 4-153: PTP PORT 1 EGRESS TIME STAMP LOW-WORD REGISTER FOR PDELAY\_REQ AND DELAY\_REQ (0X648 – 0X649): P1\_XDLY\_REQ\_TSL**

Bit	Default	R/W	Description
15 - 0	0x0000	RW	<b>PTP Port 1 Egress Time stamp for Pdelay_Req and Delay_Req in Nanoseconds [15:0]</b> This register contains port 1 egress time stamp low-word value for Pdelay_Req and Delay_Req frames in nanoseconds.

# KSZ8441HL/FHL

## 4.2.23.23 PTP Port 1 Egress Time Stamp High-Word Register for Pdelay\_Req and Delay\_Req (0x64A – 0x64B): P1\_XDLY\_REQ\_TSH

This register contains the PTP port 1 egress time stamp high-word value for Pdelay\_Req and Delay\_Req frames in nanoseconds.

**TABLE 4-154: PTP PORT 1 EGRESS TIME STAMP HIGH-WORD REGISTER FOR PDELAY\_REQ AND DELAY\_REQ (0X64A – 0X64B): P1\_XDLY\_REQ\_TSH**

Bit	Default	R/W	Description
15 - 14	00	RW	<b>PTP Port 1 Egress Time stamp for Pdelay_Req and Delay_Req in Seconds [1:0]</b> These bits are bits [1:0] of the port 1 egress time stamp value for Pdelay_Req and Delay_Req frames in seconds.
13 - 0	0x0000	RW	<b>PTP Port 1 Egress Time stamp for Pdelay_Req and Delay_Req in Nanoseconds [29:16]</b> These bits are bits [29:16] of the port 1 egress time stamp value for Pdelay_Req and Delay_Req frames in nanoseconds.

## 4.2.23.24 PTP Port 1 Egress Time Stamp Low-Word Register for Sync (0x64C – 0x64D): P1\_SYNC\_TSL

This register contains the PTP port 1 egress time stamp low-word value for Sync frame in nanoseconds.

**TABLE 4-155: PTP PORT 1 EGRESS TIME STAMP LOW-WORD REGISTER FOR SYNC (0X64C – 0X64D): P1\_SYNC\_TSL**

Bit	Default	R/W	Description
15 - 0	0x0000	RW	<b>PTP Port 1 Egress Time Stamp for Sync in Nanoseconds [15:0]</b> This register contains port 1 egress time stamp low-word value for Sync frame in nanoseconds.

## 4.2.23.25 PTP Port 1 Egress Time Stamp High-Word Register for Sync (0x64E – 0x64F): P1\_SYNC\_TSH

This register contains the PTP port 1 egress time stamp high-word value for Sync frame in nanoseconds.

**TABLE 4-156: PTP PORT 1 EGRESS TIME STAMP HIGH-WORD REGISTER FOR SYNC (0X64E – 0X64F): P1\_SYNC\_TSH**

Bit	Default	R/W	Description
15 - 14	00	RW	<b>PTP Port 1 Egress Time Stamp for Sync in Seconds [1:0]</b> These bits are bits [1:0] of the port 1 egress time stamp value for Sync frame in seconds.
13 - 0	0x0000	RW	<b>PTP Port 1 Egress Time Stamp for Sync in Nanoseconds [29:16]</b> These bits are bits [29:16] of the Port 1 egress time stamp value for Sync frame in nanoseconds.

## 4.2.23.26 PTP Port 1 Egress Time Stamp Low-Word Register for Pdelay\_Resp (0x650 – 0x651): P1\_PDLY\_RESP\_TSL

This register contains the PTP port 1 egress time stamp low-word value for Pdelay\_Resp frame in nanoseconds.

**TABLE 4-157: PTP PORT 1 EGRESS TIME STAMP LOW-WORD REGISTER FOR PDELAY\_RESP (0X650 – 0X651): P1\_PDLY\_RESP\_TSL**

Bit	Default	R/W	Description
15 - 0	0x0000	RW	<b>PTP Port 1 Egress Time Stamp for Pdelay_Resp in Nanoseconds [15:0]</b> This register contains port 1 egress time stamp low-word value for Pdelay_Resp frame in nanoseconds.

## 4.2.23.27 PTP Port 1 Egress Time Stamp High-Word Register for Pdelay\_Resp (0x652 – 0x653): P1\_PDLY\_RESP\_TSH

This register contains the PTP port 1 egress time stamp high-word value for Pdelay\_Resp frame in nanoseconds.

**TABLE 4-158: PTP PORT 1 EGRESS TIME STAMP HIGH-WORD REGISTER FOR PDELAY\_RESP (0X652 – 0X653): P1\_PDLY\_RESP\_TSH**

Bit	Default	R/W	Description
15 - 14	00	RW	<b>PTP Port 1 Egress Time Stamp for Pdelay_Resp in Seconds [1:0]</b> These bits are bits [1:0] of the port 1 egress time stamp value for Pdelay_Resp frame in seconds.
13 - 0	0x0000	RW	<b>PTP Port 1 Egress Time Stamp for Pdelay_Resp in Nanoseconds [29:16]</b> These bits are bits [29:16] of the port 1 egress time stamp high-word value for Pdelay_Resp frame in nanoseconds.

## 4.2.23.28 0x654 – 0x67F: Reserved

## 4.2.23.29 GPIO Monitor Register (0x680 - 0x681): GPIO\_MONITOR

This register contains read-only access for the current values on GPIO inputs.

**TABLE 4-159: GPIO MONITOR REGISTER (0X680 - 0X681): GPIO\_MONITOR**

Bit	Default	R/W	Description
15 - 7	0x000	RO	Reserved
6 - 0	0x00	RO	<b>GPIO Inputs Monitor</b> This field reflects the current values seen on the GPIO inputs. GPIOs 6 through 0 are mapped to bits [6:0] in order.

## 4.2.23.30 GPIO Output Enable Register (0x682 – 0x683): GPIO\_OEN

This register contains the control bits for GPIO output enable.

**TABLE 4-160: GPIO OUTPUT ENABLE REGISTER (0X682 – 0X683): GPIO\_OEN**

Bit	Default	R/W	Description
15 - 7	0x000	RO	Reserved
6 - 0	0x00	RW	<b>GPIO Output Enable</b> 0 = Enables the GPIO pin as trigger output. 1 = Enables the GPIO pin as time stamp input. GPIOs 6 through 0 are mapped to bits [6:0] in order.

## 4.2.23.31 0x684 – 0x687: Reserved

## 4.2.23.32 PTP Trigger Unit Interrupt Status Register (0x688 – 0x689): PTP\_TRIG\_IS

This register contains the interrupt status of PTP event trigger units.

**TABLE 4-161: PTP TRIGGER UNIT INTERRUPT STATUS REGISTER (0X688 – 0X689): PTP\_TRIG\_IS**

Bit	Default	R/W	Description
15 - 12	0x0	RO	Reserved
11 - 0	0x000	RO (W1C)	<b>Trigger Output Unit Interrupt Status</b> When this bit is set to 1, it indicates that the trigger output unit is done or has an error. The trigger output units from 12 to 1 are mapped to bit [11:0]. These 12 trigger output unit interrupt status bits are logical OR'ed together and connected to ISR bit [10]. Any of the interrupt status bits are cleared by writing a "1" to the particular bit.

# KSZ8441HL/FHL

## 4.2.23.33 PTP Trigger Unit Interrupt Enable Register (0x68A – 0x68B): PTP\_TRIG\_IE

This register contains the interrupt enable of PTP trigger output units.

**TABLE 4-162: PTP TRIGGER UNIT INTERRUPT ENABLE REGISTER (0X68A – 0X68B): PTP\_TRIG\_IE**

Bit	Default	R/W	Description
15 - 12	0x0	RO	Reserved
11 - 0	0x000	RW	<b>Trigger Output Unit Interrupt Enable</b> When this bit is set to “1”, it indicates that the trigger output unit interrupt is enabled. The trigger output units from 12 to 1 are mapped to bit [11:0]. These 12 trigger output unit interrupt enables are logical OR’ed together and connected to IER bit [10].

## 4.2.23.34 PTP Time stamp Unit Interrupt Status Register (0x68C – 0x68D): PTP\_TS\_IS

This register contains the interrupt status of PTP time stamp units. Each bit in this register is cleared by writing a “1” to it.

**TABLE 4-163: PTP TIME STAMP UNIT INTERRUPT STATUS REGISTER (0X68C – 0X68D): PTP\_TS\_IS**

Bit	Default	R/W	Description
15 - 14	00	RO (W1C)	Reserved
13	0	RO (W1C)	<b>Port 1 Egress Time stamp for Pdelay_Req/Resp and Delay_Req Frames Interrupt Status</b> When this bit is set to “1”, it indicates that the egress time stamp is available from port 1 for Pdelay_Req/Resp and Delay_Req frames. This bit will be logical OR’ed together with the rest of bits in this register and the logical OR’ed output is connected to ISR bit[12].
12	0	RO (W1C)	<b>Port 1 Egress Time stamp for Sync Frame Interrupt Status</b> When this bit is set to “1”, it indicates that the egress time stamp is available from port 1 for Sync frame. This bit will be logical OR’ed together with the rest of bits in this register and the logical OR’ed output is connected to ISR bit[12].
11 - 0	0x000	RO (W1C)	<b>Time stamp Unit Interrupt Status</b> When this bit is set to “1”, it indicates that the time stamp unit is ready (TS_RDY = “1”). The time stamp units from 12 to 1 are mapped to bit [11:0]. These 12 time stamp interrupts status are logical OR’ed together with the rest of bits in this register and the logical OR’ed output is connected to ISR bit[12].

## 4.2.23.35 PTP Time stamp Unit Interrupt Enable Register (0x68E – 0x68F): PTP\_TS\_IE

This register contains the interrupt enable of PTP time stamp units.

**TABLE 4-164: PTP TIME STAMP UNIT INTERRUPT ENABLE REGISTER (0X68E – 0X68F): PTP\_TS\_IE**

Bit	Default	R/W	Description
15 - 14	00	RW	Reserved
13	0	RW	<b>Port 1 Egress Time stamp for Pdelay_Req/Resp and Delay_Req Frames Interrupt Enable</b> When this bit is set to “1”, it is enabled the interrupt when the egress time stamp is available from port 1 for Pdelay_Req/Resp and Delay_Req frames. This bit will be logical OR’ed together with the rest of bits in this register and the logical OR’ed output is connected to IER bit[12].

**TABLE 4-164: PTP TIME STAMP UNIT INTERRUPT ENABLE REGISTER (0X68E – 0X68F): PTP\_TS\_IE (CONTINUED)**

Bit	Default	R/W	Description
12	0	RW	<b>Port 1 Egress Time stamp for Sync Frame Interrupt Enable</b> When this bit is set to “1”, it is enabled the interrupt when the egress time stamp is available from port 1 for Sync frame. This bit will be logical OR’ed together with the rest of bits in this register and the logical OR’ed output is connected to IER bit[12].
11 - 0	0x000	RW	<b>Time stamp Unit Interrupt Enable</b> When this bit is set to “1”, it indicates that the time stamp unit interrupt is enabled. The time stamp units from 12 to 1 are mapped to bit[11:0]. These 12 time stamp interrupts enable are logical OR’ed together with the rest of bits in this register and the logical OR’ed output is connected to IER bit[12].

4.2.23.36 0x690 – 0x733: Reserved

4.2.23.37 DSP Control 1 Register (0x734 – 0x735): DSP\_CNTRL\_6

This register contains control bits for the DSP block.

**TABLE 4-165: DSP CONTROL 1 REGISTER (0X734 – 0X735): DSP\_CNTRL\_6**

Bit	Default	R/W	Description
15 - 14	00	RW	Reserved
13	1	RW	<b>Receiver Adjustment</b> Set this bit to “1” when port 1 is in copper mode. When port 1 is in fiber mode, this bit should be cleared to “0”. Note that the fiber or copper mode is selected in the CFGR register (0x0D8 – 0x0D9).
12 - 0	0x1020	RW	Reserved

4.2.23.38 0x736 – 0x747: Reserved

4.2.23.39 Analog Control 1 Register (0x748 – 0x749): ANA\_CNTRL\_1

This register contains control bits for the analog block.

**TABLE 4-166: ANALOG CONTROL 1 REGISTER (0X748 – 0X749): ANA\_CNTRL\_1**

Bit	Default	R/W	Description
15 - 8	0x00	RW	Reserved
7	0	RW	<b>LDO Off</b> This bit is used to control the on/off state of the internal low-voltage regulator. 0 = LDO On (Default) 1 = Turn LDO Off
6 - 0	0x00	RW	Reserved

4.2.23.40 0x74A – 0x74B: Reserved

4.2.23.41 Analog Control 3 Register (0x74C – 0x74D): ANA\_CNTRL\_3

This register contains control bits for the analog block.

**TABLE 4-167: ANALOG CONTROL 3 REGISTER (0X74C – 0X74D): ANA\_CNTRL\_3**

Bit	Default	R/W	Description
15	0	RW	<b>HIPLS3 Mask</b> This bit must be set prior to initiating the LinkMD function.

# KSZ8441HL/FHL

**TABLE 4-167: ANALOG CONTROL 3 REGISTER (0X74C – 0X74D): ANA\_CNTRL\_3 (CONTINUED)**

Bit	Default	R/W	Description
14 - 4	0x000	RW	Reserved
3	0	RW	<b>BTRX Reduce</b> This bit must be set prior to initiating the LinkMD function.
2 - 0	000	RW	Reserved

4.2.23.42 0x74E – 0x7FF: Reserved

## 4.3 Management Information Base (MIB) Counters

The KSZ8441 provides 34 MIB counters for each port. These counters are used to monitor the port activity for network management. The MIB counters are formatted “per port” and “all ports dropped packet” as shown in [Table 4-168](#).

**TABLE 4-168: FORMAT OF PER-PORT MIB COUNTERS**

Bit	Name	R/W	Description	Default
31	Overflow	RO	1 = Counter overflow. 0 = No counter overflow.	0
30	Count Valid	RO	1 = Counter value is valid. 0 = Counter value is not valid.	0
29 - 0	Counter Values	RO	Counter value (read clear)	0x00000000

Port 1 MIB counters are read using indirect memory access. The port 1 base address is 0x00 and range is from 0x00 to 0x1F.

Port 1 MIB counters are read using indirect access control in the IACR register and the indirect access data registers in IADR4[15:0], IADR5[31:16] (0x026 – 0x02F). The port 1 MIB counters address memory offset as in [Table 4-169](#).

**TABLE 4-169: PORT 1 MIB COUNTERS – INDIRECT MEMORY OFFSET**

Offset	Counter Name	Description
0x0	RxLoPriorityByte	Rx lo-priority (default) octet count including bad packets.
0x1	RxHiPriorityByte	Rx hi-priority octet count including bad packets.
0x2	RxUndersizePkt	Rx undersize packets with good CRC.
0x3	RxFragments	Rx fragment packets with bad CRC, symbol errors or alignment errors.
0x4	RxOversize	Rx oversize packets with good CRC (maximum: 2000 bytes).
0x5	RxJabbers	Rx packets longer than 1522 bytes with either CRC errors, alignment errors, or symbol errors (depends on max packet size setting).
0x6	RxSymbolError	Rx packets w/ invalid data symbol and legal packet size.
0x7	RxCRCError	Rx packets within (64,1522) bytes w/ an integral number of bytes and a bad CRC (upper limit depends on maximum packet size setting).
0x8	RxAlignmentError	Rx packets within (64,1522) bytes w/ a non-integral number of bytes and a bad CRC (upper limit depends on maximum packet size setting).
0x9	RxControl8808Pkts	Number of MAC control frames received by a port with 88-08h in EtherType field.
0xA	RxPausePkts	Number of PAUSE frames received by a port. PAUSE frame is qualified with EtherType (88-08h), DA, control opcode (00-01), data length (64B minimum), and a valid CRC.
0xB	RxBroadcast	Rx good broadcast packets (not including error broadcast packets or valid multicast packets).
0xC	RxMulticast	Rx good multicast packets (not including MAC control frames, error multicast packets or valid broadcast packets).
0xD	RxUnicast	Rx good unicast packets.
0xE	Rx64Octets	Total Rx packets (bad packets included) that were 64 octets in length.



**TABLE 4-169: PORT 1 MIB COUNTERS – INDIRECT MEMORY OFFSET (CONTINUED)**

Offset	Counter Name	Description
0xF	Rx65to127Octets	Total Rx packets (bad packets included) that are between 65 and 127 octets in length.
0x10	Rx128to255Octets	Total Rx packets (bad packets included) that are between 128 and 255 octets in length.
0x11	Rx256to511Octets	Total Rx packets (bad packets included) that are between 256 and 511 octets in length.
0x12	Rx512to1023Octets	Total Rx packets (bad packets included) that are between 512 and 1023 octets in length.
0x13	Rx1024to2000Octets	Total Rx packets (bad packets included) that are between 1024 and 2000 octets in length (upper limit depends on max packet size setting).
0x14	TxLoPriorityByte	Tx lo-priority good octet count, including PAUSE packets.
0x15	TxHiPriorityByte	Tx hi-priority good octet count, including PAUSE packets.
0x16	TxLateCollision	The number of times a collision is detected later than 512 bit-times into the Tx of a packet.
0x17	TxPausePkts	Number of PAUSE frames transmitted by a port.
0x18	TxBroadcastPkts	Tx good broadcast packets (not including error broadcast or valid multi-cast packets).
0x19	TxMulticastPkts	Tx good multicast packets (not including error multicast packets or valid broadcast packets).
0x1A	TxUnicastPkts	Tx good unicast packets.
0x1B	TxDeferred	Tx packets by a port for which the 1st Tx attempt is delayed due to the busy medium.
0x1C	TxTotalCollision	Tx total collision, half duplex only.
0x1D	TxExcessiveCollision	A count of frames for which Tx fails due to excessive collisions.
0x1E	TxSingleCollision	Successfully Tx frames on a port for which Tx is inhibited by exactly one collision.
0x1F	TxMultipleCollision	Successfully Tx frames on a port for which Tx is inhibited by more than one collision.

**TABLE 4-170: "ALL PORTS DROPPED PACKET" MIB COUNTER FORMAT**

Bit	Default	R/W	Description
30 - 16	—	N/A	Reserved
15 - 0	0x0000	RO	Counter Value

**Note:** "All Ports Dropped Packet" MIB Counters do not indicate overflow or validity; therefore, the application must keep track of overflow and valid conditions.

"All Ports Dropped Packet" MIB counters are read using indirect memory access. The address offsets for these counters are in [Table 4-171](#).

**TABLE 4-171: "ALL PORTS DROPPED PACKET" MIB COUNTERS – INDIRECT MEMORY OFFSETS**

Offset	Counter Name	Description
0x100	Port 1 TX Drop Packets	TX packets dropped due to lack of resources
0x101	N/A	—
0x102	N/A	—
0x103	Port 1 RX Drop Packets	RX packets dropped due to lack of resources
0x104	N/A	—
0x105	N/A	—

# KSZ8441HL/FHL

---

## Examples:

1. MIB Counter Read (read port 1 “Rx64Octets” counter at indirect address offset 0x0E)

Write to Reg. IACR with 0x1C0E (set indirect address and trigger a read MIB counters operation)

Then:

Read Reg. IADR5 (MIB counter value [31:16]) // If bit [31] = “1”, there was a counter overflow // If bit [30] = “0”, restart (re-read) from this register

Read Reg. IADR4 (MIB counter value [15:0])

2. MIB Counter Read (read “Port 1 TX Drop Packets” counter at indirect address offset 0x100)

Write to Reg. IACR with 0x1D00 (set indirect address and trigger a read MIB counters operation)

Then

Read Reg. IADR4 (MIB counter value [15:0])

### 4.3.1 ADDITIONAL MIB INFORMATION

Port 1 MIB counters are designed as “read clear”. That is, these counters will be cleared after they are read.

“All Ports Dropped Packet” MIB counters are not cleared after they are accessed. The application needs to keep track of overflow and valid conditions on these counters.

## 5.0 OPERATIONAL CHARACTERISTICS

### 5.1 Absolute Maximum Ratings\*

Supply Voltage ( $V_{DD\_A3.3}$ , $V_{DD\_IO}$ ) .....	-0.5V to +5.0V
Supply Voltage ( $V_{DD\_AL}$ , $V_{DD\_L}$ ) .....	-0.5V to +1.8V
Input Voltage (All Inputs) .....	-0.5V to +5.0V
Output Voltage (All Outputs) .....	-0.5V to +5.0V
Lead Temperature (soldering, 20s) .....	+260°C
Storage Temperature ( $T_S$ ) .....	-65°C to +150°C
Maximum Junction Temperature ( $T_J$ ) .....	+125°C
HBM ESD Rating .....	2 kV

\*Exceeding the absolute maximum rating may damage the device. Stresses greater than the absolute maximum rating may cause permanent damage to the device. Operation of the device at these or any other conditions above those specified in the operating sections of this specification is not implied. Maximum conditions for extended periods may affect reliability.

### 5.2 Operating Ratings\*\*

Supply Voltage	
$V_{DDA\_3.3}$ .....	+3.135V to +3.465V
$V_{DD\_L}$ , $V_{DD\_AL}$ , $V_{DD\_COL}$ .....	+1.25V to +1.4V
$V_{DD\_IO}$ (3.3V) .....	+3.135V to +3.465V
$V_{DD\_IO}$ (2.5V) .....	+2.375 to +2.625V
$V_{DD\_IO}$ (1.8V) .....	+1.71V to +1.89V
Ambient Operating Temperature ( $T_A$ )	
Industrial .....	-40°C to +85°C
Thermal Resistance (Note 5-1)	
Junction-to-Ambient ( $\Theta_{JA}$ ) .....	+49°C/W
Junction-to-Case ( $\Theta_{JC}$ ) .....	+19°C/W

\*\*The device is not guaranteed to function outside its operating ratings. Unused inputs must always be tied to an appropriate logic voltage level (GROUND to  $V_{DD\_IO}$ ).

**Note:** Do not drive input signals without power supplied to the device.

**Note 5-1** No heat spreader (HS) in this package. The  $\Theta_{JC}/\Theta_{JA}$  is under air velocity 0m/s.

# KSZ8441HL/FHL

## 6.0 ELECTRICAL CHARACTERISTICS

TABLE 6-1: ELECTRICAL CHARACTERISTICS (Note 6-1)

Parameters	Symbol	Min.	Typ.	Max.	Units	Note
<b>Supply Current for 100BASE-TX Operation</b> (Internal Low-Voltage Regulator On, $V_{DD\_A3.3} = 3.3V$ , $V_{DD\_IO} = 3.3V$ ) (Note 6-1)						
—	$I_{VDD\_A3.3}$	—	25	—	mA	100% traffic
	$I_{VDD\_IO}$	—	79	—	mA	
	$PD_{ISS\_DEVICE}$	—	341	—	mW	
—	$I_{VDD\_A3.3}$	—	25	—	mA	Link, no Traffic, EEE Feature is off
	$I_{VDD\_IO}$	—	77	—	mA	
	$PD_{ISS\_DEVICE}$	—	335	—	mW	
—	$I_{VDD\_A3.3}$	—	4.3	—	mA	Port 1 Powered Down (P1CR4 bit[11] = "1")
	$I_{VDD\_IO}$	—	69	—	mA	
	$PD_{ISS\_DEVICE}$	—	240	—	mW	
—	$I_{VDD\_A3.3}$	—	4.7	—	mA	Port 1 Not Connected, using EDPD Feature (PMCTRL bits[1:0] = "01")
	$I_{VDD\_IO}$	—	68	—	mA	
	$PD_{ISS\_DEVICE}$	—	241	—	mW	
—	$I_{VDD\_A3.3}$	—	5.1	—	mA	Port 1 Connected, No Traffic, using EEE Feature
	$I_{VDD\_IO}$	—	68	—	mA	
	$PD_{ISS\_DEVICE}$	—	243	—	mW	
—	$I_{VDD\_A3.3}$	—	0.98	—	mA	Soft Power-Down Mode (PMCTRL bits[1:0] = "10")
	$I_{VDD\_IO}$	—	2.0	—	mA	
	$PD_{ISS\_DEVICE}$	—	10	—	mW	
—	$I_{VDD\_A3.3}$	—	0.18	—	mA	Hardware Power-Down Mode While the PWDRN pin (pin 17) is Held Low.
	$I_{VDD\_IO}$	—	0	—	mA	
	$PD_{ISS\_DEVICE}$	—	0.6	—	mW	
<b>Supply Current for 100BASE-TX Operation</b> (Internal Low-Voltage Regulator Off, $V_{DD\_A3.3}$ and $V_{DD\_IO} = 3.3V$ ; $V_{DD\_L}$ , $V_{DD\_AL}$ , and $V_{DD\_COL} = 1.4V$ ) (Note 6-1)						
—	$I_{VDD\_A3.3}$	—	24	—	mA	100% Traffic
	$I_{VDD\_IO}$	—	2.6	—	mA	
	$I_{VDD\_AL} + I_{VDD\_DL}$	—	78	—	mA	
	$PD_{ISS\_DEVICE}$	—	196	—	mW	
—	$I_{VDD\_A3.3}$	—	24	—	mA	Link, no Traffic, EEE Feature is off.
	$I_{VDD\_IO}$	—	1.0	—	mA	
	$I_{VDD\_AL} + I_{VDD\_DL}$	—	76	—	mA	
	$PD_{ISS\_DEVICE}$	—	189	—	mW	
—	$I_{VDD\_A3.3}$	—	3.6	—	mA	Port 1 Powered Down (P1CR4 bit[11] = "1")
	$I_{VDD\_IO}$	—	0.8	—	mA	
	$I_{VDD\_AL} + I_{VDD\_DL}$	—	71	—	mA	
	$PD_{ISS\_DEVICE}$	—	114	—	mW	

**TABLE 6-1: ELECTRICAL CHARACTERISTICS (Note 6-1) (CONTINUED)**

Parameters	Symbol	Min.	Typ.	Max.	Units	Note
—	$I_{VDD\_A3.3}$	—	4.0	—	mA	Port 1 Not Connected, using EDPD Feature (PMCTRL bits[1:0] = "01")
	$I_{VDD\_IO}$	—	0.8	—	mA	
	$I_{VDD\_AL} + I_{VDD\_DL}$	—	70	—	mA	
	$PDISS_{DEVICE}$	—	114	—	mW	
—	$I_{VDD\_A3.3}$	—	4.4	—	mA	Port 1 Connected, No Traffic, using EEE Feature
	$I_{VDD\_IO}$	—	1.0	—	mA	
	$I_{VDD\_AL} + I_{VDD\_DL}$	—	69	—	mA	
	$PDISS_{DEVICE}$	—	114	—	mW	
—	$I_{VDD\_A3.3}$	—	1.2	—	mA	Soft Power-Down Mode (PMCTRL bits[1:0] = "10")
	$I_{VDD\_IO}$	—	0.7	—	mA	
	$I_{VDD\_AL} + I_{VDD\_DL}$	—	0.9	—	mA	
	$PDISS_{DEVICE}$	—	8	—	mW	
—	$I_{VDD\_A3.3}$	—	1.2	—	mA	Hardware Power-Down Mode While the PWDRN pin (pin 17) is Held Low.
	$I_{VDD\_IO}$	—	0.7	—	mA	
	$I_{VDD\_AL} + I_{VDD\_DL}$	—	1.0	—	mA	
	$PDISS_{DEVICE}$	—	8	—	mW	
<b>Supply Current for 10BASE-T Operation (Internal Low-Voltage Regulator On, <math>V_{DD\_A3.3} = 3.3V</math>, <math>V_{DD\_IO} = 3.3V</math>) (Note 6-1)</b>						
—	$I_{VDD\_A3.3}$	—	28	—	mA	100% Traffic
	$I_{VDD\_IO}$	—	71	—	mA	
	$PDISS_{DEVICE}$	—	328	—	mW	
—	$I_{VDD\_A3.3}$	—	12	—	mA	Link, No Traffic
	$I_{VDD\_IO}$	—	70	—	mA	
	$PDISS_{DEVICE}$	—	269	—	mW	
<b>Supply Current for 10BASE-T Operation (Internal Low-Voltage Regulator Off, <math>V_{DD\_A3.3}</math> and <math>V_{DD\_IO} = 3.3V</math>; <math>V_{DD\_L}</math>, <math>V_{DD\_AL}</math>, and <math>V_{DD\_COL} = 1.4V</math>) (Note 6-1)</b>						
—	$I_{VDD\_A3.3}$	—	27	—	mA	100% Traffic
	$I_{VDD\_IO}$	—	1.7	—	mA	
	$I_{VDD\_AL} + I_{VDD\_DL}$	—	72	—	mA	
	$PDISS_{DEVICE}$	—	197	—	mW	
—	$I_{VDD\_A3.3}$	—	11	—	mA	Link, No Traffic
	$I_{VDD\_IO}$	—	0.9	—	mA	
	$I_{VDD\_AL} + I_{VDD\_DL}$	—	71	—	mA	
	$PDISS_{DEVICE}$	—	138	—	mW	
<b>Internal Voltage Regulator Output Voltage</b>						
Output Voltage at $V_{DD\_L}$	$V_{LDO}$	—	1.32	—	V	$V_{DD\_IO} = 2.5V$ or $3.3V$ ; internal regulator enabled; measured at pins 40 and 51

# KSZ8441HL/FHL

**TABLE 6-1: ELECTRICAL CHARACTERISTICS (Note 6-1) (CONTINUED)**

Parameters	Symbol	Min.	Typ.	Max.	Units	Note
<b>CMOS Inputs (<math>V_{DD\_IO} = 3.3V/2.5V/1.8V</math>)</b>						
Input High Voltage	$V_{IH}$	2.1/1.7/ 1.3	—	—	V	—
Input Low Voltage	$V_{IL}$	—	—	0.9/0.9/ 0.6	V	—
Input Current	$I_{IN}$	-10	—	10	$\mu A$	$V_{IN} = GND \sim V_{DD\_IO}$
<b>X1 Crystal/Osc Input Pin</b>						
Input High Voltage	$V_{IH}$	2.1	—	—	V	—
Input Low Voltage	$V_{IL}$	—	—	0.9	V	—
Input Current	$I_{IN}$	—	—	10	$\mu A$	—
<b>PWRDN Input</b>						
Input High Voltage	$V_{IH}$	1.1	—	—	V	$V_{DD\_A3.3} = 3.3V, V_{DD\_IO} = \text{any}$
Input Low Voltage	$V_{IL}$	—	—	0.3	V	$V_{DD\_A3.3} = 3.3V, V_{DD\_IO} = \text{any}$
<b>FXSD Input</b>						
Input High Voltage	$V_{IH}$	2.1	—	—	V	$V_{DD\_A3.3} = 3.3V, V_{DD\_IO} = \text{any}$
Input Low Voltage	$V_{IL}$	—	—	1.2	V	$V_{DD\_A3.3} = 3.3V, V_{DD\_IO} = \text{any}$
<b>CMOS Outputs (<math>V_{DD\_IO} = 3.3V/2.5V/1.8V</math>)</b>						
Output High Voltage	$V_{OH}$	2.4/1.9/ 1.5	—	—	V	$I_{OH} = -8 \text{ mA}$
Output Low Voltage	$V_{OL}$	—	—	0.4/0.4/ 0.2	V	$I_{OL} = 8 \text{ mA}$
Output Tri-State Leakage	$ I_{OZ} $	—	—	10	$\mu A$	—
<b>100BASE-TX Transmit (Measured Differentially After 1:1 Transformer)</b>						
Peak Differential Output Voltage	$V_O$	$\pm 0.95$	—	$\pm 1.05$	V	100 $\Omega$ termination on the diff. output
Output Voltage Imbalance	$V_{IMB}$	—	—	2	%	100 $\Omega$ termination on the diff. output
Rise/Fall Time	$t_r/t_f$	3	—	5	ns	—
Rise/Fall Time Imbalance	—	0	—	0.5	ns	—
Duty Cycle Distortion	—	—	—	$\pm 0.25$	ns	—
Overshoot	—	—	—	5	%	—
Reference Voltage of ISET	$V_{SET}$	—	0.65	—	V	Using 6.49 k $\Omega$ resistor
Output Jitter	—	—	0.7	1.4	ns	Peak-to-peak
<b>10BASE-T Receive</b>						
Squelch Threshold	$V_{SQ}$	—	400	—	mV	5 MHz square wave
<b>10BASE-T Transmit (Measured Differentially After 1:1 Transformer)</b>						
Peak Differential Output Voltage	$V_P$	2.2	2.5	2.8	V	100 $\Omega$ termination on the differential output
Jitter Added	—	—	1.8	3.5	ns	100 $\Omega$ termination on the differential output (peak-to-peak)
Rise/Fall Time	$t_r/t_f$	—	25	—	ns	—
<b>LED Outputs</b>						
Output Drive Current	$I_{LED}$	—	8	—	mA	Each LED pin (P1LED0, P1LED1)

**Note 6-1**  $I_{VDD\_A3.3}$  measured at pin 9.  $I_{VDD\_IO}$  measured at pins 21, 30, and 56.  $I_{VDD\_AL}$  measured at pins 6 and 16.  $I_{VDD\_DL}$  measured at pins 40 and 51.

**Note 6-2**  $T_A = 25^\circ C$ . Specification is for packaged product only.

## 7.0 TIMING SPECIFICATIONS

### 7.1 Host Interface Read/Write Timing

**FIGURE 7-1: HOST INTERFACE READ/WRITE TIMING**

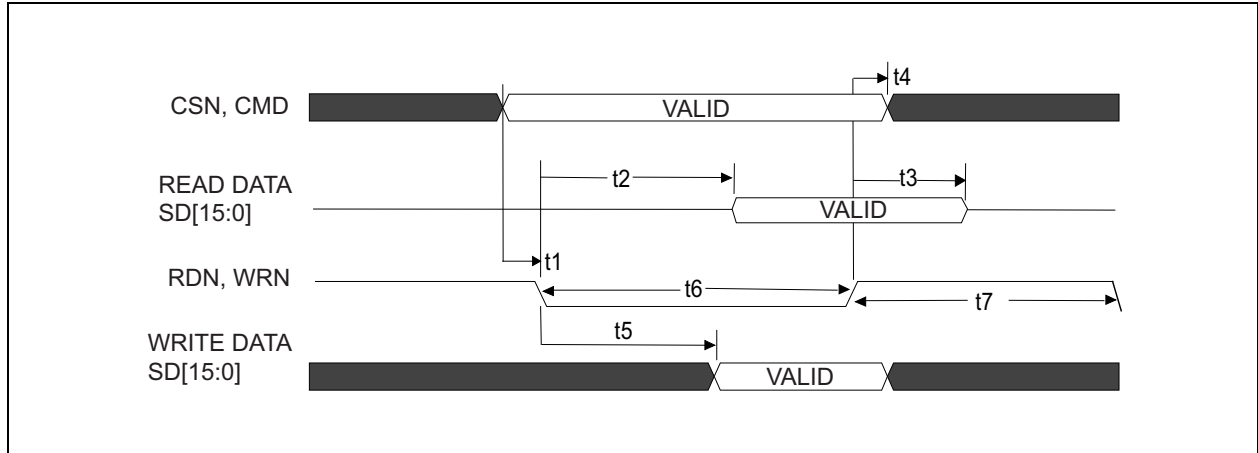

**TABLE 7-1: HOST INTERFACE READ/WRITE TIMING PARAMETERS**

Symbol	Parameter	Min.	Typ.	Max.	Units
t1	CSN, CMD valid to RDN, WRN active	0	—	—	ns
t2	RDN active to Read Data SD[15:0] valid Note: This is the SD output delay after RDN becomes active until valid read data is available.	24	—	32	ns
t3	RDN inactive to Read data invalid Note: The processor latches valid read data at the rising edge of RDN	1	—	2	ns
t4	CSN, CMD hold time after RDN, WRN inactive	0	—	—	ns
t5	WRN active to write data valid (bit [12] = 0 in RXFDPR)	8	—	16	ns
	WRN active to write data valid (bit [12] = 1 in RXFDPR) Note: It is better if the processor can provide data in less than 4 ns after WRN is active. If the processor provides data more than 4 ns after WRN is active, make sure that RXFDPR bit [12] = 0.	—	—	4	ns
t6	RDN Read active time (low)	40	—	—	ns
	WRN Write active time (low)	40	—	—	ns
t7	RDN Read Inactive time (high)	10	—	—	ns
	WRN Write inactive time (high)	10	—	—	ns

# KSZ8441HL/FHL

## 7.2 Auto-Negotiation Timing

FIGURE 7-2: AUTO-NEGOTIATION TIMING

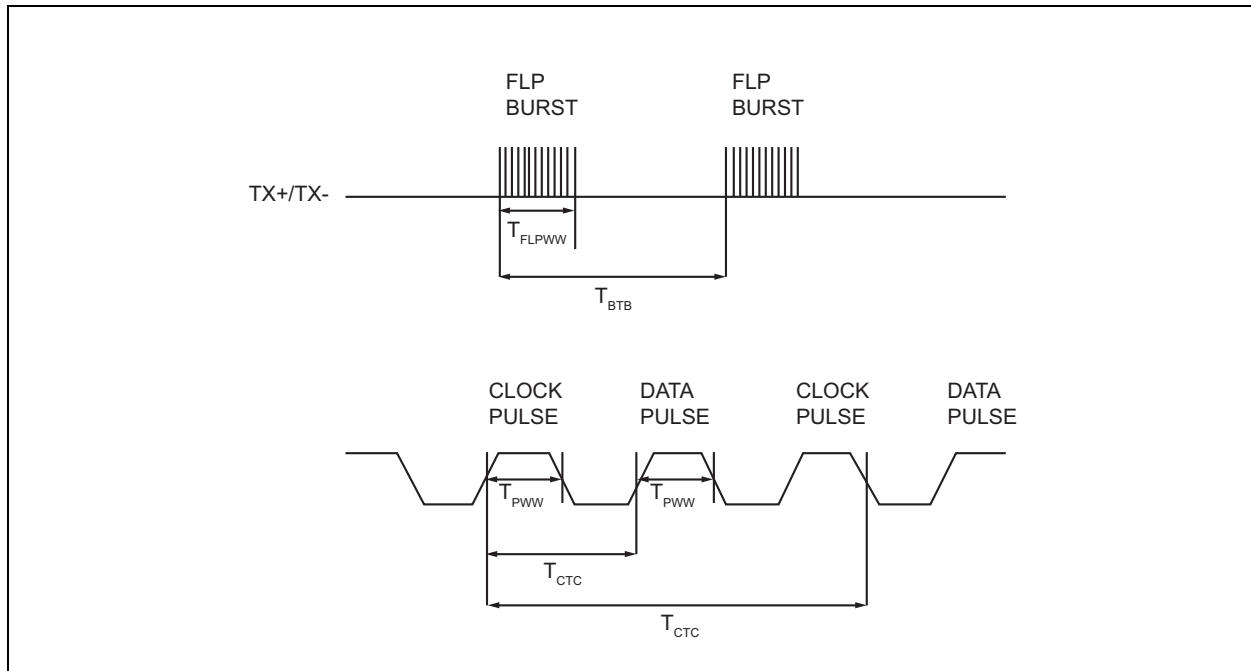

TABLE 7-2: AUTO-NEGOTIATION TIMING PARAMETERS

Parameter	Description	Min.	Typ.	Max.	Units
$t_{BTB}$	FLP Burst to FLP Burst	8	16	24	ms
$t_{FLPW}$	FLP Burst Width	—	2	—	ms
$t_{PW}$	Clock/Data Pulse Width	—	100	—	ns
$t_{CTD}$	Clock Pulse to Data Pulse	55.5	64	69.5	$\mu$ s
$t_{CTC}$	Clock Pulse to Clock Pulse	111	128	139	$\mu$ s
—	Number of Clock/Data Pulses per FLP Burst	17	—	33	—



## 7.3 Trigger Output Unit and Time Stamp Input Unit Timing

The timing information in the following figure provides details and constraints on various timing relationships within the twelve trigger output units and the time stamp input units.

**FIGURE 7-3: TRIGGER OUTPUT UNIT AND TIME STAMP INPUT UNIT TIMING**

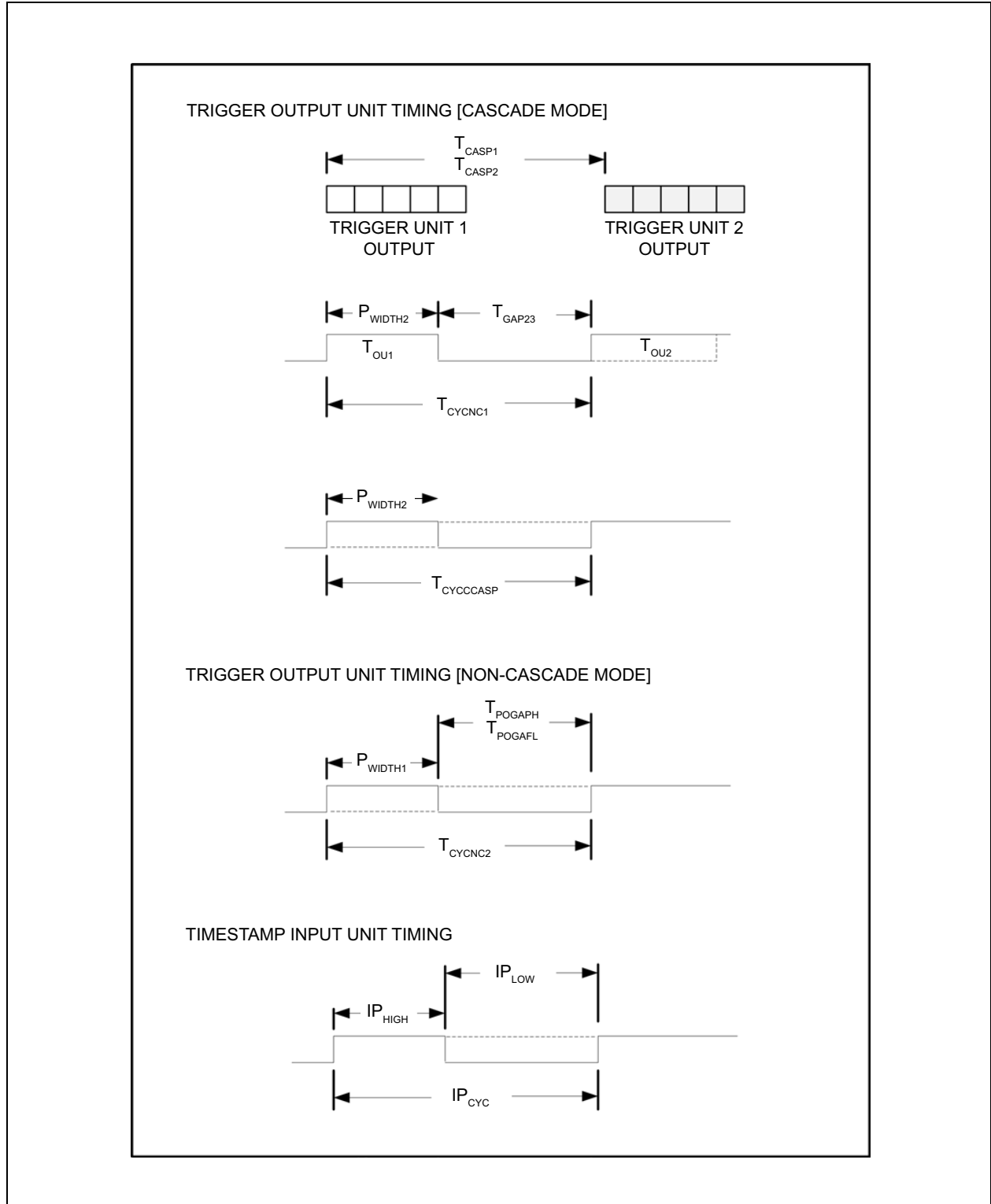

# KSZ8441HL/FHL

**TABLE 7-3: TRIGGER OUTPUT UNIT AND TIME STAMP INPUT UNIT TIMING PARAMETERS**

Parameter	Description	Min.	Typ.	Max.	Units
<b>Trigger Output Unit Timing [Cascade Mode]</b>					
$T_{CASP1}$	In cascade mode for TRIGX_CFG_1[6:4] = 100, or 101, or 110 (Neg. Edge, Pos. Edge, and Shift Reg. Output signals). Minimum time between start of one TOU and the start of another TOU cascaded on the same GPIO pin.	80	—	—	ns
$T_{CASP2}$	In cascade mode for TRIGX_CFG_1[6:4] = 010, 011, 100, or 101 (Neg. Pulse, Pos. Pulse, Neg. Periodic, and Pos. Periodic Output signals). Minimum time between start of one TOU and the start of another TOU cascaded on the same GPIO pin.	120	—	—	ns
$T_{CYCCASP}$	In cascade mode for TRIGX_CFG_1[6:4] = 010, and 011 (Neg. Pulse, Pos. Pulse Output signals). In cascade mode, the cycle time of the trigger output unit operating in the indicated modes.	80	$\geq 32 + P_{WIDTH2}$		ns
$T_{CYCNC1}$	In cascade mode for TRIGX_CFG_1[6:4] = 100 or 101 (Neg. Periodic, Pos. periodic Output signals). Minimum cycle time for any trigger output unit operating in the indicated modes.	80	$\geq 32 + P_{WIDTH2}$		ns
$T_{GAP23}$	In cascade mode for TRIGX_CFG_1[6:4] = 010, and 011 (Neg. Pulse, Pos. Pulse Output signals): Minimum gap time required between end of period of first trigger output unit to beginning of output of 2nd trigger output unit.	80	—	—	ns
$P_{WIDTH2}$	In cascade mode, the minimum low or high pulse width of the trigger output unit.	8	—	—	ns
<b>Trigger Output Unit Timing [Non-Cascade Mode]</b>					
$T_{CYCNC2}$	In non-cascade mode, the minimum cycle time for any trigger output unit.	80	$\geq 32 + P_{WIDTH2}$		ns
$T_{POGAP}$	In non-cascade mode, the minimum time between the end of the generated pulse to the start of the next pulse.	32	—	—	ns
$P_{WIDTH1}$	In non-cascade mode, the minimum low or high pulse width of the trigger output unit.	8	—	—	ns
<b>Time Stamp Input Unit Timing</b>					
$IP_{HIGH}$	Allowable high time of an incoming digital waveform on any GPIO pin	24	—	—	ns
$IP_{LOW}$	In non-cascade mode, the minimum time between the end of the generated pulse to the start of the next pulse.	24	—	—	ns
$IP_{CYC}$	In non-cascade mode, the minimum time between the end of the generated pulse to the start of the next pulse.	48	—	—	ns

## 7.4 Serial EEPROM Interface Timing

FIGURE 7-4: SERIAL EEPROM TIMING

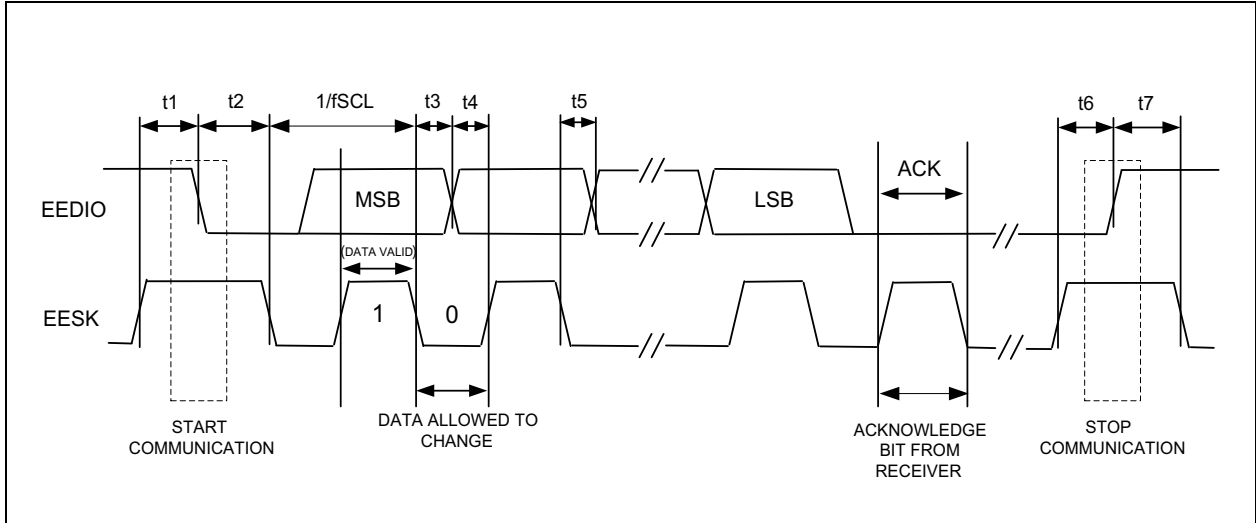

TABLE 7-4: SERIAL EEPROM TIMING PARAMETERS

Parameter	Description	Min.	Typ.	Max.	Units
$f_{SCL}$	EESK Clock Frequency	—	—	2.5	MHz
$t_1$	Setup Time for Start Bit	33	—	—	ns
$t_2$	Hold Time for Start Bit	33	—	—	ns
$t_3$	Hold Time for Data	20	—	—	ns
$t_4$	Setup Time for Data	33	—	—	ns
$t_5$	Output Valid Time for Data	60	—	—	ns
$t_6$	Setup Time for Stop Bit	33	—	—	ns
$t_7$	Hold Time for Stop Bit	33	—	—	ns

# KSZ8441HL/FHL

## 7.5 Reset and Power Sequence Timing

The KSZ8441 reset timing and power sequence requirements are summarized in the following figure and table.

**FIGURE 7-5: RESET AND POWER SEQUENCE TIMING**

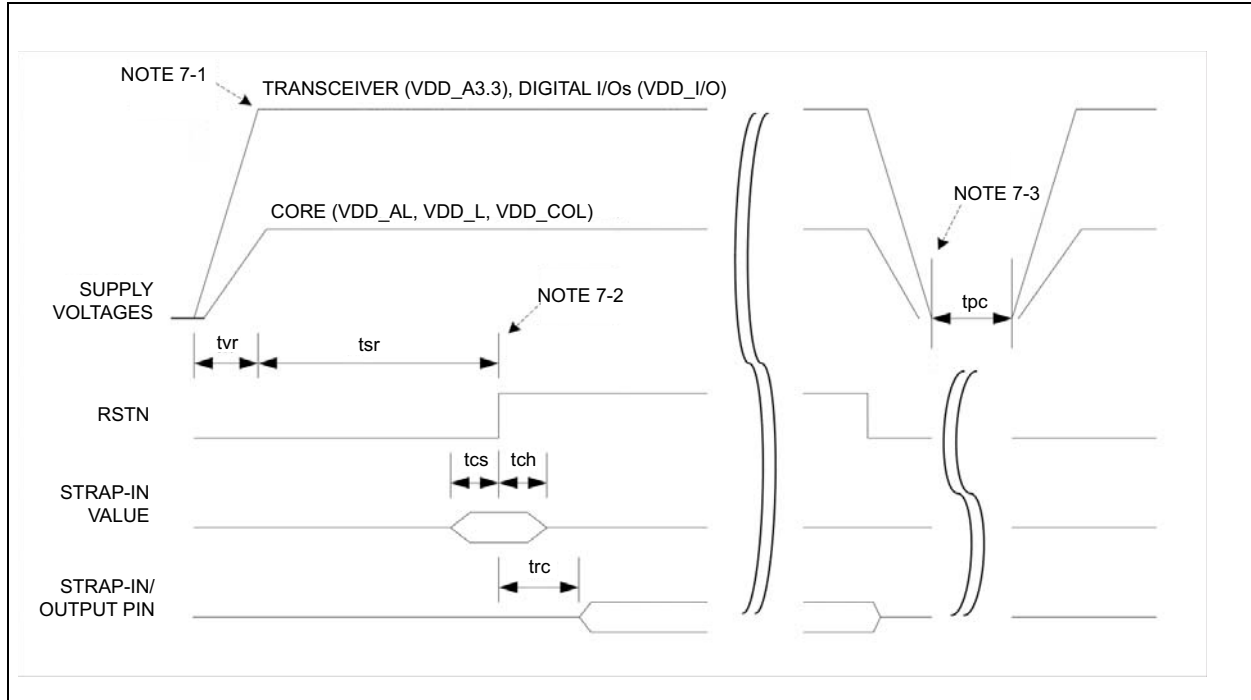

**TABLE 7-5: RESET AND POWER SEQUENCE TIMING PARAMETERS**  
(Note 7-1, Note 7-2, Note 7-3)

Parameter	Description	Min.	Typ.	Max.	Units
$t_{VR}$	Supply voltages rise time (must be monotonic)	0	—	—	$\mu\text{s}$
$t_{SR}$	Stable supply voltages to de-assertion of reset	10	—	—	ms
$t_{CS}$	Strap-in pin configuration setup time	5	—	—	ns
$t_{CH}$	Strap-in pin configuration hold time	5	—	—	ns
$t_{RC}$	De-assertion of reset to strap-in pin output	6	—	—	ns

**Note 7-1** The recommended powering sequence is to bring up all voltages at the same time. However, if that cannot be attained, then a recommended power-up sequence is to have the transceiver ( $V_{DD\_A3.3}$ ) and digital I/Os ( $V_{DD\_IO}$ ) voltages power up before the low voltage core ( $V_{DD\_AL}$ ,  $V_{DD\_L}$ , and  $V_{DD\_COL}$ ) voltage, if an external low voltage core supply is used. There is no power sequence requirement between transceiver ( $V_{DD\_A3.3}$ ) and digital I/Os ( $V_{DD\_IO}$ ) power rails. The power-up waveforms should be monotonic for all supply voltages to the KSZ8441.

**Note 7-2** After the de-assertion of reset, it is recommended to wait a minimum of 100  $\mu\text{s}$  before starting programming of the device through any interface.

**Note 7-3** The recommended power-down sequence is to have the low voltage core voltage power down first before powering down the transceiver and digital I/O voltages.

## 7.6 Reset Circuit Guidelines

The following reset circuit is recommended for powering up the KSZ8441 device if reset is triggered by the power supply.

**FIGURE 7-6: SIMPLE RESET CIRCUIT**

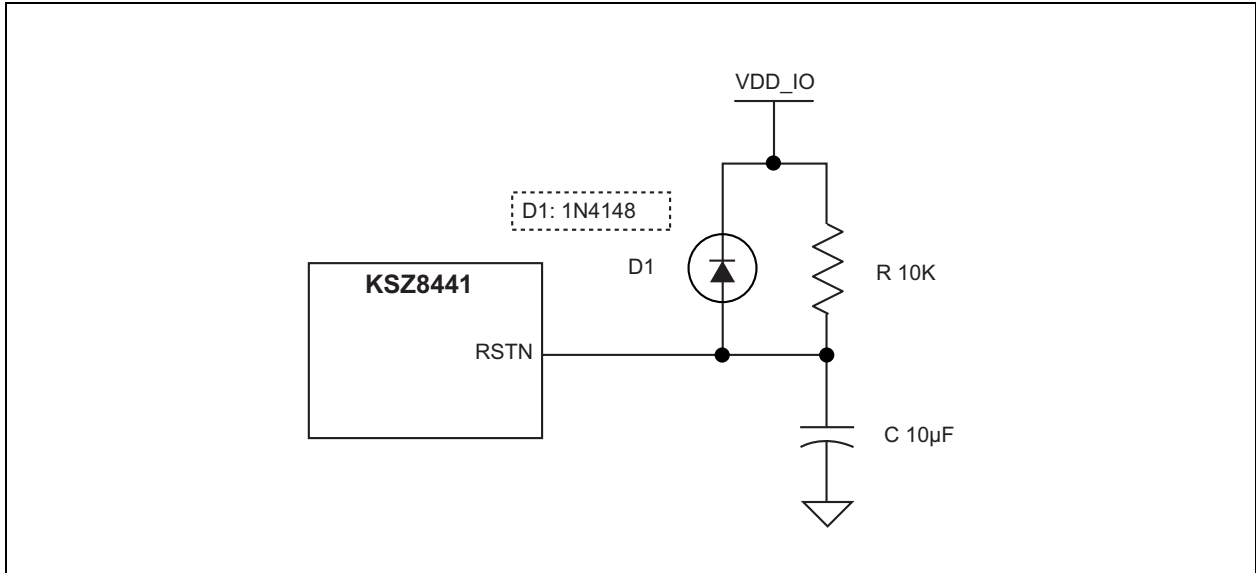

The following reset circuit is recommended for applications where reset is driven by another device (e.g., CPU or FPGA). At POR, R, C, and D1 provide the necessary ramp rise time to reset the KSZ8441 device. The RST\_OUT\_N from CPU/FPGA provides the warm reset after power-up.

**FIGURE 7-7: RECOMMENDED RESET CIRCUIT FOR INTERFACING WITH CPU/FPGA RESET OUTPUT**

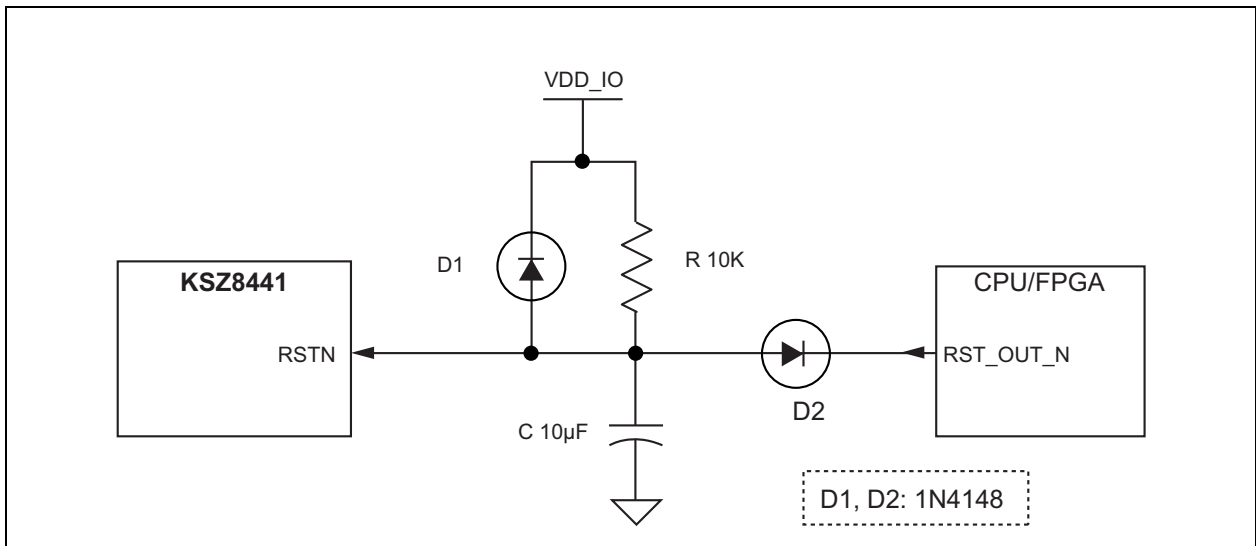

# KSZ8441HL/FHL

## 8.0 REFERENCE CIRCUIT: LED STRAP-IN PINS

The pull-up and pull-down reference circuits for the P1LED0/H816 strapping pin are shown in [Figure 8-1](#).

The supply voltage for the LEDs must be at least ~2.2V, depending on the particular LED and the load resistor. If VDD\_IO is 1.8V, then a different (higher voltage) supply must be used for the LEDs.

**FIGURE 8-1: TYPICAL LED STRAP-IN CIRCUIT**

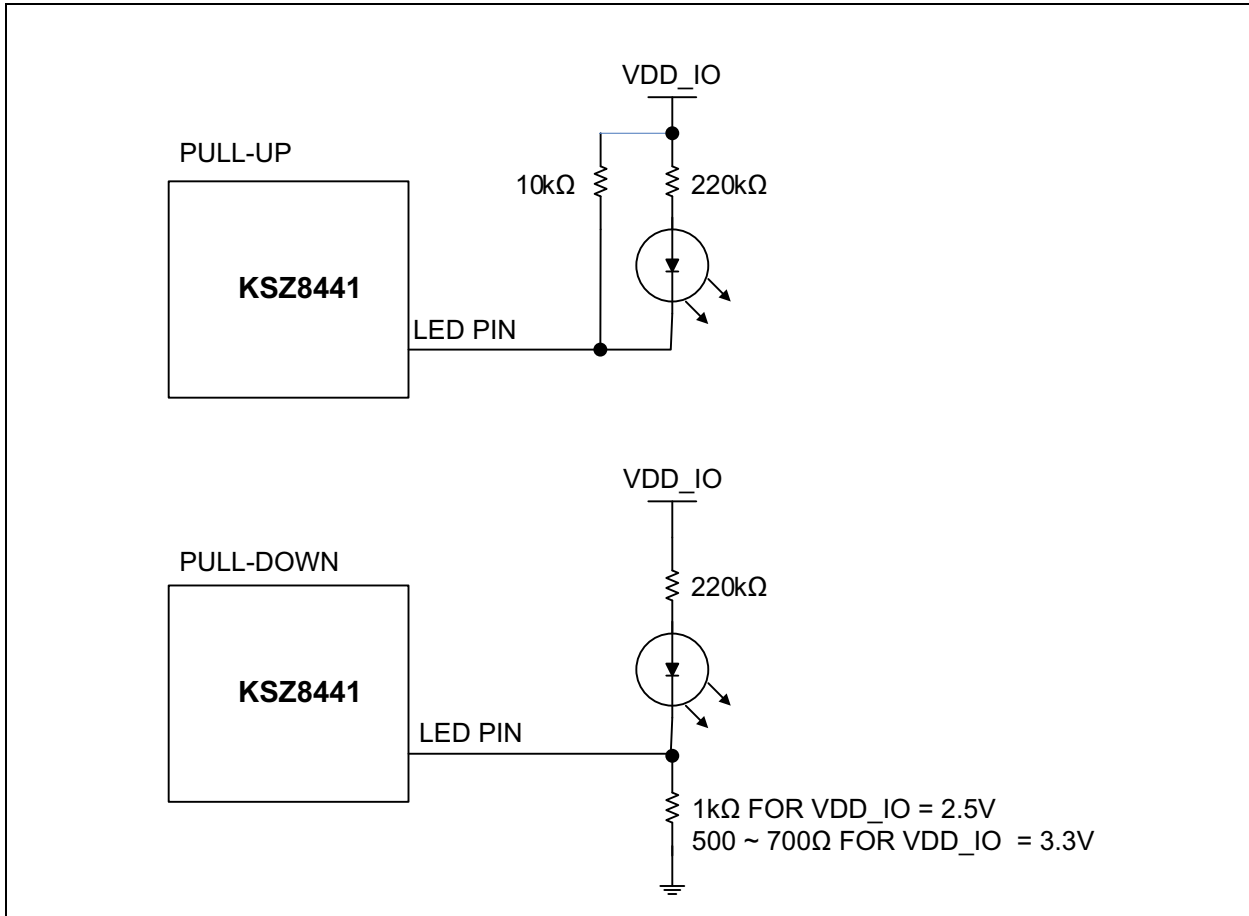

## 9.0 REFERENCE CLOCK: CONNECTION AND SELECTION

Figure 9-1 shows a crystal or external clock source, such as an oscillator, as the reference clock for the KSZ8441. The reference clock is 25 MHz for all operating modes of the KSZ8441. If an oscillator is used, connect it to X1, and leave X2 unconnected.

The resistor shown on X2 is optional and can be used to reduce the current to the crystal if needed, depending on the specific crystal that is used. The maximum recommended resistor value is 30Ω.

**FIGURE 9-1: 25MHZ CRYSTAL AND OSCILLATOR CLOCK CONNECTION OPTIONS**

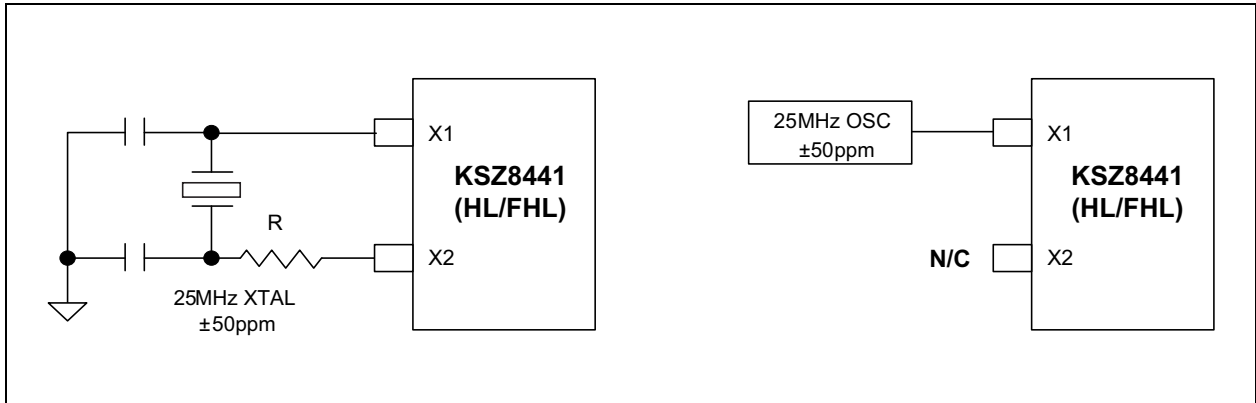

**TABLE 9-1: TYPICAL REFERENCE CRYSTAL CHARACTERISTICS**

Characteristics	Value
Frequency	25 MHz
Frequency tolerance (maximum)	±50 ppm
Effective Series resistance (maximum)	50Ω

# KSZ8441HL/FHL

## 10.0 SELECTION OF ISOLATION TRANSFORMERS

A 1:1 isolation transformer is required at the line interface. An isolation transformer with integrated common-mode choke is recommended for exceeding FCC requirements.

Table 10-1 lists recommended transformer characteristics.

**TABLE 10-1: TRANSFORMER SELECTION CRITERIA**

Parameter	Value	Test Conditions
Turns Ratio	1 CT:1 CT	—
Open-Circuit Inductance (min.)	350 $\mu$ H	100 mV, 100 kHz, 8 mA
Leakage Inductance (max.)	0.4 $\mu$ H	1 MHz (min.)
Interwinding Capacitance (max.)	12 pF	—
D.C. Resistance (max.)	0.9 $\Omega$	—
Insertion Loss (max.)	-1.0 dB	100 kHz to 100 MHz
HIPOT (min.)	1500 V <sub>RMS</sub>	—

**TABLE 10-2: QUALIFIED SINGLE-PORT MAGNETICS**

Manufacturer	Part Number	Auto MDI-X
Pulse	H1102NL	Yes
Pulse (low cost)	H1260	Yes
Transpower	HB726	Yes
Bel Fuse	S558-5999-U7	Yes
Delta	LF8505	Yes
LanKom	LF-H41S	Yes
TDK (Mag Jack)	TLA-6T718	Yes



## 11.0 PACKAGE OUTLINE

**FIGURE 11-1: 64-LEAD LQFP 10 MM X 10 MM PACKAGE OUTLINE & RECOMMENDED LAND PATTERN**

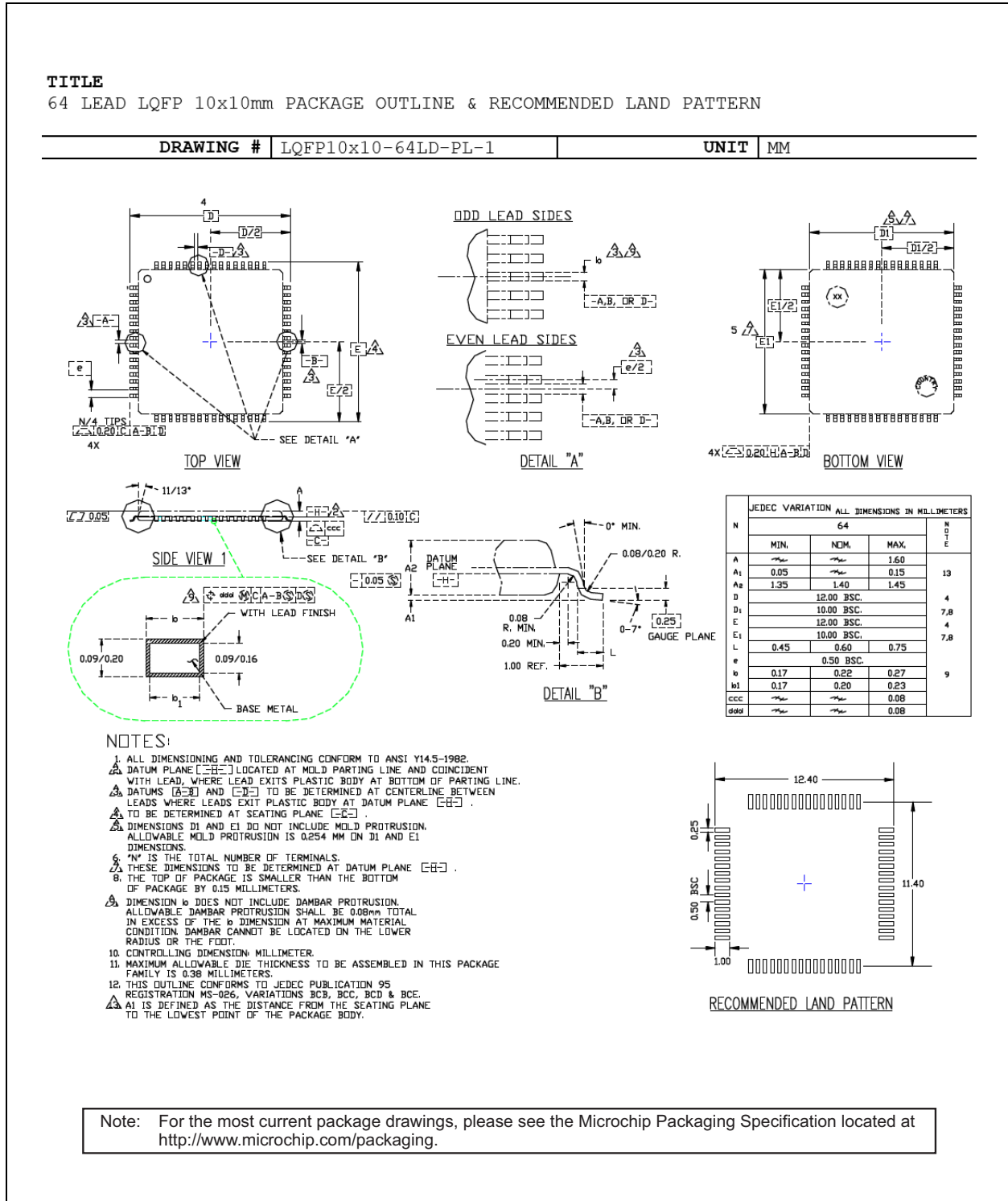

# KSZ8441HL/FHL

---

## APPENDIX A: DATA SHEET REVISION HISTORY

TABLE A-1: REVISION HISTORY

Revision	Section/Figure/Entry	Correction
DS00002640A (2-22-18)	—	Converted Micrel data sheet KSZ8441HL/FHL to Microchip DS00002640A. Minor text changes throughout.

## THE MICROCHIP WEB SITE

Microchip provides online support via our WWW site at [www.microchip.com](http://www.microchip.com). This web site is used as a means to make files and information easily available to customers. Accessible by using your favorite Internet browser, the web site contains the following information:

- **Product Support** – Data sheets and errata, application notes and sample programs, design resources, user's guides and hardware support documents, latest software releases and archived software
- **General Technical Support** – Frequently Asked Questions (FAQ), technical support requests, online discussion groups, Microchip consultant program member listing
- **Business of Microchip** – Product selector and ordering guides, latest Microchip press releases, listing of seminars and events, listings of Microchip sales offices, distributors and factory representatives

## CUSTOMER CHANGE NOTIFICATION SERVICE

Microchip's customer notification service helps keep customers current on Microchip products. Subscribers will receive e-mail notification whenever there are changes, updates, revisions or errata related to a specified product family or development tool of interest.

To register, access the Microchip web site at [www.microchip.com](http://www.microchip.com). Under "Support", click on "Customer Change Notification" and follow the registration instructions.

## CUSTOMER SUPPORT

Users of Microchip products can receive assistance through several channels:

- Distributor or Representative
- Local Sales Office
- Field Application Engineer (FAE)
- Technical Support

Customers should contact their distributor, representative or field application engineer (FAE) for support. Local sales offices are also available to help customers. A listing of sales offices and locations is included in the back of this document.

**Technical support is available through the web site at: <http://microchip.com/support>**

# KSZ8441HL/FHL

## PRODUCT IDENTIFICATION SYSTEM

To order or obtain information, e.g., on pricing or delivery, refer to the factory or the listed sales office.

<u>PART NO.</u>	X	X	X	—	XX
Device	Interface	Package	Temperature		Media Type
<b>Device:</b>	KSZ8441				
<b>Interface:</b>	H = Generic Host Bus Interface FH = Generic Host Bus Interface with Fiber support				
<b>Package:</b>	L = 64-Lead LQFP				
<b>Temperature:</b>	I = -40°C to +85°C (Industrial)				
<b>Media Type:</b>	<blank> = 160/Tray				

**Examples:**

a) KSZ8441HLI: Generic Host Bus Interface, 64-Lead LQFP, Industrial Temperature, 160/Tray

b) KSZ8441FHLL: Generic Host Bus Interface with Fiber Support, 64-Lead LQFP, Industrial Temperature, 160/Tray

---

**Note the following details of the code protection feature on Microchip devices:**

- Microchip products meet the specification contained in their particular Microchip Data Sheet.
- Microchip believes that its family of products is one of the most secure families of its kind on the market today, when used in the intended manner and under normal conditions.
- There are dishonest and possibly illegal methods used to breach the code protection feature. All of these methods, to our knowledge, require using the Microchip products in a manner outside the operating specifications contained in Microchip's Data Sheets. Most likely, the person doing so is engaged in theft of intellectual property.
- Microchip is willing to work with the customer who is concerned about the integrity of their code.
- Neither Microchip nor any other semiconductor manufacturer can guarantee the security of their code. Code protection does not mean that we are guaranteeing the product as “unbreakable.”

Code protection is constantly evolving. We at Microchip are committed to continuously improving the code protection features of our products. Attempts to break Microchip's code protection feature may be a violation of the Digital Millennium Copyright Act. If such acts allow unauthorized access to your software or other copyrighted work, you may have a right to sue for relief under that Act.

---

Information contained in this publication regarding device applications and the like is provided only for your convenience and may be superseded by updates. It is your responsibility to ensure that your application meets with your specifications. MICROCHIP MAKES NO REPRESENTATIONS OR WARRANTIES OF ANY KIND WHETHER EXPRESS OR IMPLIED, WRITTEN OR ORAL, STATUTORY OR OTHERWISE, RELATED TO THE INFORMATION, INCLUDING BUT NOT LIMITED TO ITS CONDITION, QUALITY, PERFORMANCE, MERCHANTABILITY OR FITNESS FOR PURPOSE. Microchip disclaims all liability arising from this information and its use. Use of Microchip devices in life support and/or safety applications is entirely at the buyer's risk, and the buyer agrees to defend, indemnify and hold harmless Microchip from any and all damages, claims, suits, or expenses resulting from such use. No licenses are conveyed, implicitly or otherwise, under any Microchip intellectual property rights unless otherwise stated.

**Trademarks**

The Microchip name and logo, the Microchip logo, AnyRate, AVR, AVR logo, AVR Freaks, BeaconThings, BitCloud, CryptoMemory, CryptoRF, dsPIC, FlashFlex, flexPWR, Helder, JukeBlox, KEELOQ, KEELOQ logo, Kleer, LANCheck, LINK MD, maXStylus, maXTouch, MediaLB, megaAVR, MOST, MOST logo, MPLAB, OptoLyzer, PIC, picoPower, PICSTART, PIC32 logo, Prochip Designer, QTouch, RightTouch, SAM-BA, SpyNIC, SST, SST Logo, SuperFlash, tinyAVR, UNI/O, and XMEGA are registered trademarks of Microchip Technology Incorporated in the U.S.A. and other countries.

ClockWorks, The Embedded Control Solutions Company, EtherSynch, Hyper Speed Control, HyperLight Load, IntelliMOS, mTouch, Precision Edge, and Quiet-Wire are registered trademarks of Microchip Technology Incorporated in the U.S.A.

Adjacent Key Suppression, AKS, Analog-for-the-Digital Age, Any Capacitor, AnyIn, AnyOut, BodyCom, chipKIT, chipKIT logo, CodeGuard, CryptoAuthentication, CryptoCompanion, CryptoController, dsPICDEM, dsPICDEM.net, Dynamic Average Matching, DAM, ECAN, EtherGREEN, In-Circuit Serial Programming, ICSP, Inter-Chip Connectivity, JitterBlocker, KleerNet, KleerNet logo, Mindi, MiWi, motorBench, MPASM, MPF, MPLAB Certified logo, MPLIB, MPLINK, MultiTRAK, NetDetach, Omniscient Code Generation, PICDEM, PICDEM.net, PICkit, PICtail, PureSilicon, QMatrix, RightTouch logo, REAL ICE, Ripple Blocker, SAM-ICE, Serial Quad I/O, SMART-I.S., SQI, SuperSwitcher, SuperSwitcher II, Total Endurance, TSHARC, USBCheck, VariSense, ViewSpan, WiperLock, Wireless DNA, and ZENA are trademarks of Microchip Technology Incorporated in the U.S.A. and other countries.

SQTP is a service mark of Microchip Technology Incorporated in the U.S.A.

Silicon Storage Technology is a registered trademark of Microchip Technology Inc. in other countries.

GestIC is a registered trademark of Microchip Technology Germany II GmbH & Co. KG, a subsidiary of Microchip Technology Inc., in other countries.

All other trademarks mentioned herein are property of their respective companies.

© 2018, Microchip Technology Incorporated, All Rights Reserved.

ISBN: 978-1-5224-2708-7

**QUALITY MANAGEMENT SYSTEM**  
**CERTIFIED BY DNV**  
**== ISO/TS 16949 ==**

*Microchip received ISO/TS-16949:2009 certification for its worldwide headquarters, design and wafer fabrication facilities in Chandler and Tempe, Arizona; Gresham, Oregon and design centers in California and India. The Company's quality system processes and procedures are for its PIC® MCUs and dsPIC® DSCs, KEELOQ® code hopping devices, Serial EEPROMs, microperipherals, nonvolatile memory and analog products. In addition, Microchip's quality system for the design and manufacture of development systems is ISO 9001:2000 certified.*

---

**NOTES:**



# MICROCHIP

## Worldwide Sales and Service

### AMERICAS

**Corporate Office**  
2355 West Chandler Blvd.  
Chandler, AZ 85224-6199  
Tel: 480-792-7200  
Fax: 480-792-7277  
Technical Support:  
<http://www.microchip.com/support>  
Web Address:  
[www.microchip.com](http://www.microchip.com)

#### Atlanta

Duluth, GA  
Tel: 678-957-9614  
Fax: 678-957-1455

#### Austin, TX

Tel: 512-257-3370

#### Boston

Westborough, MA  
Tel: 774-760-0087  
Fax: 774-760-0088

#### Chicago

Itasca, IL  
Tel: 630-285-0071  
Fax: 630-285-0075

#### Dallas

Addison, TX  
Tel: 972-818-7423  
Fax: 972-818-2924

#### Detroit

Novi, MI  
Tel: 248-848-4000

#### Houston, TX

Tel: 281-894-5983

#### Indianapolis

Noblesville, IN  
Tel: 317-773-8323  
Fax: 317-773-5453  
Tel: 317-536-2380

#### Los Angeles

Mission Viejo, CA  
Tel: 949-462-9523  
Fax: 949-462-9608  
Tel: 951-273-7800

#### Raleigh, NC

Tel: 919-844-7510

#### New York, NY

Tel: 631-435-6000

#### San Jose, CA

Tel: 408-735-9110  
Tel: 408-436-4270

#### Canada - Toronto

Tel: 905-695-1980  
Fax: 905-695-2078

### ASIA/PACIFIC

**Australia - Sydney**  
Tel: 61-2-9868-6733

**China - Beijing**  
Tel: 86-10-8569-7000

**China - Chengdu**  
Tel: 86-28-8665-5511

**China - Chongqing**  
Tel: 86-23-8980-9588

**China - Dongguan**  
Tel: 86-769-8702-9880

**China - Guangzhou**  
Tel: 86-20-8755-8029

**China - Hangzhou**  
Tel: 86-571-8792-8115

**China - Hong Kong SAR**  
Tel: 852-2943-5100

**China - Nanjing**  
Tel: 86-25-8473-2460

**China - Qingdao**  
Tel: 86-532-8502-7355

**China - Shanghai**  
Tel: 86-21-3326-8000

**China - Shenyang**  
Tel: 86-24-2334-2829

**China - Shenzhen**  
Tel: 86-755-8864-2200

**China - Suzhou**  
Tel: 86-186-6233-1526

**China - Wuhan**  
Tel: 86-27-5980-5300

**China - Xian**  
Tel: 86-29-8833-7252

**China - Xiamen**  
Tel: 86-592-2388138

**China - Zhuhai**  
Tel: 86-756-3210040

### ASIA/PACIFIC

**India - Bangalore**  
Tel: 91-80-3090-4444

**India - New Delhi**  
Tel: 91-11-4160-8631

**India - Pune**  
Tel: 91-20-4121-0141

**Japan - Osaka**  
Tel: 81-6-6152-7160

**Japan - Tokyo**  
Tel: 81-3-6880-3770

**Korea - Daegu**  
Tel: 82-53-744-4301

**Korea - Seoul**  
Tel: 82-2-554-7200

**Malaysia - Kuala Lumpur**  
Tel: 60-3-7651-7906

**Malaysia - Penang**  
Tel: 60-4-227-8870

**Philippines - Manila**  
Tel: 63-2-634-9065

**Singapore**  
Tel: 65-6334-8870

**Taiwan - Hsin Chu**  
Tel: 886-3-577-8366

**Taiwan - Kaohsiung**  
Tel: 886-7-213-7830

**Taiwan - Taipei**  
Tel: 886-2-2508-8600

**Thailand - Bangkok**  
Tel: 66-2-694-1351

**Vietnam - Ho Chi Minh**  
Tel: 84-28-5448-2100

### EUROPE

**Austria - Wels**  
Tel: 43-7242-2244-39  
Fax: 43-7242-2244-393

**Denmark - Copenhagen**  
Tel: 45-4450-2828  
Fax: 45-4485-2829

**Finland - Espoo**  
Tel: 358-9-4520-820

**France - Paris**  
Tel: 33-1-69-53-63-20  
Fax: 33-1-69-30-90-79

**Germany - Garching**  
Tel: 49-8931-9700

**Germany - Haan**  
Tel: 49-2129-3766400

**Germany - Heilbronn**  
Tel: 49-7131-67-3636

**Germany - Karlsruhe**  
Tel: 49-721-625370

**Germany - Munich**  
Tel: 49-89-627-144-0  
Fax: 49-89-627-144-44

**Germany - Rosenheim**  
Tel: 49-8031-354-560

**Israel - Ra'anana**  
Tel: 972-9-744-7705

**Italy - Milan**  
Tel: 39-0331-742611  
Fax: 39-0331-466781

**Italy - Padova**  
Tel: 39-049-7625286

**Netherlands - Drunen**  
Tel: 31-416-690399  
Fax: 31-416-690340

**Norway - Trondheim**  
Tel: 47-7289-7561

**Poland - Warsaw**  
Tel: 48-22-3325737

**Romania - Bucharest**  
Tel: 40-21-407-87-50

**Spain - Madrid**  
Tel: 34-91-708-08-90  
Fax: 34-91-708-08-91

**Sweden - Gothenberg**  
Tel: 46-31-704-60-40

**Sweden - Stockholm**  
Tel: 46-8-5090-4654

**UK - Wokingham**  
Tel: 44-118-921-5800  
Fax: 44-118-921-5820