

■ Features

- Fully integrated AM/FM radio solution with simple control interfaces and direct support for LCD display:
 - Integrated channel, volume, band control
 - Versatile tuning interfaces including dial mode, keyboard mode and incremental encoder mode.
 - AM/FM LO frequency output to support SC3610
- Worldwide FM/AM band support
 - FM: 32MHz-110MHz
 - AM: 500KHz-1710KHz
- Fully integrated frequency synthesizer with no external components
- High Sensitivity
 - 1.6uVEMF for FM
 - 16uVEMF for AM
- High Fidelity
 - SNR (FM/AM): 60dB/55dB
 - THD: 0.3%
- Low Supply Current
 - 22mA (operating)
 - <15uA (standby)
- Channel and volume store in standby mode
- Low supply voltage: 2.2V to 3.6V, can be supplied with 2 AAA batteries
- Support 32.768KHz reference clock
- Small form factor SSOP16L package
- RoHS Compliant

■ Applications

Desktop and portable radio, campus radio, mini/portable audio systems, clock radio, PMP docking station, car audio system, toy and gift.

Rev. 1.2

Information furnished by KT Micro is believed to be accurate and reliable. However, no responsibility is assumed by KT Micro for its use, nor for any infringements of patents or other rights of third parties which may result from its use. No license is granted by implication or otherwise under any patent or patent rights of KT Micro, Inc.

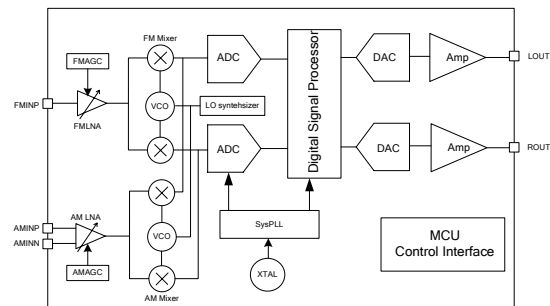

KT0911 System Diagram

■ Description

The KT0911 is a fully integrated AM/FM radio chip with patented technologies that delivers superior audio and RF performance, supports direct and simple interface for tuning wheel and push button, and directly interfaces with application-specific LCD displays such as SC3610.

Thanks to its advanced system architecture, the KT0911 offers an excellent user listening experience with high sensitivity, high signal-to-noise ratio, low distortion and low sensitivity to interference.

KT0911 provides direct and simple interface to support multiple tuning schemes, such as tuning wheel and push button. It eliminates many components used in traditional radios while maintaining the user experience with digital enhancements.

The unique LO output enables KT0911 to work directly with the low cost and widely used frequency and clock display IC, SC3610 and its compatibles, thus offers highly integrated and low cost AM/FM radio and clock solutions with digital display.

Thanks to its high integration level, KT0911 lowers the system cost, simplifies design, and improves product reliability and manufacturability. KT0911 can operate with two AAA batteries, making it an ideal for portable radios that require LCD displays.

**KT Micro Inc., 22391 Gilberto, Suite D
Rancho Santa Margarita, CA 92688
Tel: 949.713.4000 <http://www.ktmicro.com.cn>
Fax: 949.713.4004 Copyright ©2010, KT Micro, Inc.**

Table of Content

1. Electrical Specification.....	3
2. Pin List	5
3. Function Description	6
3.1. Overview	6
3.2. FM Receiver.....	6
3.3. AM Receiver	6
3.4. Operation Bands.....	6
3.5. Standby	7
3.6. User-Machine Interface	7
3.6.1. Key Mode.....	7
3.6.2. Dial Mode.....	8
3.6.3. Incremental Encoder Mode	11
3.7. Chip Configuration	11
3.8. Register Bank	13
3.8.1. FMSYSCFG (Address 0x02)	14
3.8.2. FMCHAN (Address 0x03)	14
3.8.3. AUCFGA (Address 0x04).....	14
3.8.4. AUCFGB (Address 0x05).....	15
3.8.5. LOCFG (Address 0x0A)	15
3.8.6. VOLUME (Address 0x0F).....	16
3.8.7. AMSYSCFG (Address 0x16).....	16
3.8.8. AMCHAN (Address 0x17)	16
3.8.9. GPIOCFG (Address 0x1D)	16
3.8.10. AMDSP (Address 0x22)	17
3.8.11. AMCFGA (Address 0x33).....	18
3.8.12. AMCFGB (Address 0x34h)	18
3.8.13. CHANGUARDA (Address 0x38h).....	19
3.8.14. CHANGUARDB (Address 0x39h).....	19
3.8.15. VOLGUARD (Address 0x3Ah).....	19
4. Typical Application Circuit.....	21
5. Revision History	26
6. Contact Information.....	26

1. Electrical Specification

Table 1: Operation Condition

Parameter	Symbol	Operating Condition	Min	Typ	Max	Units
Power Supply	AVDD	Relative to AVss	2.2	3.3	3.6	V
Ambient Temperature	Ta		-30	25	70	°C

Table 2: DC Characteristics

Parameter	Symbol	Test/Operating Condition	Min	Typ	Max	Units
Current Consumption	FM Mode	I _{FM}	-	21.3	-	mA
	AM Mode	I _{AM}		22		mA
Standby Current	I _{APD}			14.5		μA

Table 3: FM Receiver Characteristics

(Unless otherwise noted Ta = -30~70 °C, VDD= 2.2V to 3.6V)

Parameter	Symbol	Test/Operating Condition	Min	Typ	Max	Units
FM Frequency Range	F _{rx}		32		110	MHz
Sensitivity ^{1,2,3}	Sen	(S+N)/N=26dB		1.6	2	uVemf
Input referred 3 rd Order Intermodulation Production ^{4,5}	IIP3			85		dBuVE MF
Adjacent Channel Selectivity		±200KHz	35		51	dB
Alternate Channel Selectivity		±400KHz	50		70	dB
Image Rejection Ratio				35		dB
AM suppression				50		dB
RCLK frequency			-	32.768	-	KHz
RCLK frequency Range ⁸			-100		100	ppm
Audio Output Voltage ^{1,2,3,4}		32ohm load	90	100	110	mV _{RMS}
Audio Band Limits ^{1,2,4}		±3dB	30		15K	Hz
Audio Stereo Separation ^{1,4,6}			35			dB
Audio Mono S/N ^{1,2,3,4}			55	60		dB
Audio Stereo S/N ^{1,4,6,7}		DBLND=1		64		dB
Audio THD ^{1,2,4,6}				0.3		%
De-emphasis Time Constant		DE=0		75		μs
		DE=1		50		μs
Audio Common Mode Voltage				0.85		V
Audio Output Load Resistance	R _L	Single-ended		32		Ω
Power-up Time					600	ms

Notes:

1. F_{MOD}=1KHz, 75us de-emphasis
2. MONO=1
3. ΔF=22.5KHz
4. V_{EMF}=1mV, Frx=32MHz~110MHz
5. AGCD=1
6. ΔF=75KHz
7. VOLUME<4:0>=11111
8. The supported RCLK frequency is not continuous. Please refer to application notes.

Table 4: AM Receiver Characteristics

(Unless otherwise noted Ta = -30~70 °C, VDD= 2.2V to 3.6V)

Parameter	Symbol	Test/Operating Condition	Min	Typ	Max	Units
AM Frequency Range	F _{rx}		500		1710	KHz
Sensitivity ^{1,2}	Sen	(S+N)/N=26dB		16		uVemf
Audio Output Voltage ^{1,2,3,4}		32ohm load		60		mV _{RMS}
Audio Mono S/N ^{1,2,3,4}				55		dB
Audio THD ^{1,2,4,6}				0.3	0.6	%
Antenna inductance	L		280	350	420	uH
Notes: 1. F _{MOD} =1KHz 2. Modulation index is 30% 3. V _{EMF} =1mV, F _{rx} =500KHz~1710KHz 4. VOLUME<4:0>=11111						

2. Pin List

Table 5: Pin list

Pin	Pin Name	Description
1	CH	Channel adjustment signal input
2	LO_OUT	Output the LO frequency to SC3610.
3	DVSS	Digital ground.
4	ROUT	Right channel audio output.
5	LOUT	Left channel audio output.
6	AVSS	Analog ground.
7	AVDD	Power supply
8	RCLK	32.768KHz reference clock input
9	ENABLE	Chip enable pin. Has an internal 600kohm pull down resistor
10	AMINN	AM RF negative input.
11	AMINP	AM RF positive input.
12	RFINP	FM RF input
13	RFGND	RF ground.
14	AM_FM	AM/FM-SEL Signal Output for 3610 chip.
15	SPAN	Band switching control pin.
16	VOL	Volume adjustment signal input

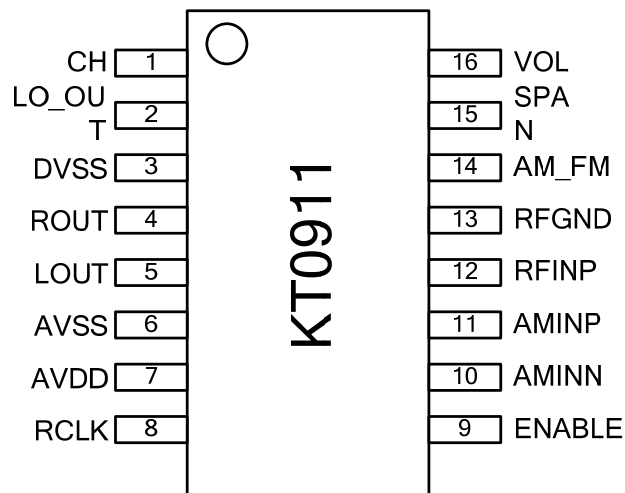

Figure 1: KT0911 Pin Assignment (Top View)

3. Function Description

3.1. Overview

KT0911 offers a true single-chip, full-band FM/AM and versatile radio solution by minimizing the external components and offering a variety of configurations.

3.2. FM Receiver

The FM receiver is based on the architecture of KT Micro's latest generation FM receiver chips in mass production. There are no external filters or frequency-tuning devices thanks to a proprietary digital low-IF architecture consisting of a fully-integrated LNA, an automatic gain control (AGC), a set of high-performance ADCs, high-quality analog and digital filters, and an on-chip low-noise self-tuning VCO. The on-chip high-fidelity Class-AB driver further eliminates the need for external audio amplifiers and can drive stereo headphones directly.

3.3. AM Receiver

The AM Receiver employs a similar digital low IF architecture and shares many circuits with the FM receiver. The AM receiver supports a wide band from 500KHz to 1710KHz also known as the popular MW bands. The AM channel spacing can be set to 1KHz, 9KHz or 10KHz to address applications in different regions. The bandwidth of the channel filter can be set to 2KHz, 4KHz or 6KHz to suit various requirements by setting register AM_BW<1:0>.

The AM receiver in KT0911 can provide accurate and automatic AM tuning without manual alignment. It supports 350uH ferrite loop antenna with +/- 25% tolerance.

3.4. Operation Bands

KT0911 supports wide FM bands and MW bands. The FM receiver covers frequencies from 32MHz to 110MHz and groups them into 3 bands, namely, FM1(86 to 109MHz), FM2(64MHz to 91MHz) and FM3(32MHz to 64MHz). The FM2 and FM3 band can be disabled by setting register FM_BAND_NUM<1:0> to 10 or 01. Furthermore, if FM_BAND_NUM<1:0> is set to 01, the frequency range of the remaining FM band is determined by register BAND<1:0>. KT0911 supports 3 different channel steps for FM band, 50KHz, 100KHz and 200KHz, which are specified in register FMSPACE<1:0>. The MW band is from 500KHz to 1710KHz if the channel step is set to 1KHz or 10KHz and is from 504KHz to 1710KHz if the channel step is set to 9KHz. The channel step of MW band is set by register AMSPACE<1:0>.

3.5. Standby

To enter standby mode, the ENABLE pin is pulled down to ground. During standby mode, the internal state (channel, volume and span) is preserved and can be recovered when the chip wakes up from the standby mode.

3.6. User-Machine Interface

KT0911 offers multiple user-machine interface options including Key Mode (push button), Dial Mode (tuning wheel) and Incremental Encoder Mode.

3.6.1. Key Mode

KT0911 allows user to control the channel and volume by using keys/buttons to send digital control signals to CH, VOL and SPAN pins. Please refer to Figure 9 for a typical application circuit. The key mode is enabled by setting GPIO1<1:0>=01, GPIO2<1:0>=01, GPIO3<1:0>=01, GPIO4<1:0>=11 and SPAN_MODE=1, respectively.

The band-switching is controlled by the button connected to SPAN pin, which is shown in Figure 2, when the register GPIO3<1:0> and SPAN_MODE are set to 01 and 1, respectively. Each time the SPAN key is pressed, the band of KT0911 is cycled in the following sequence, FM1→FM2→FM3→AM→FM1, where the number of FM bands and their frequency range can be adjusted by register FM_BAND_NUM<1:0> and BAND<1:0>, which is described in section 3.4.

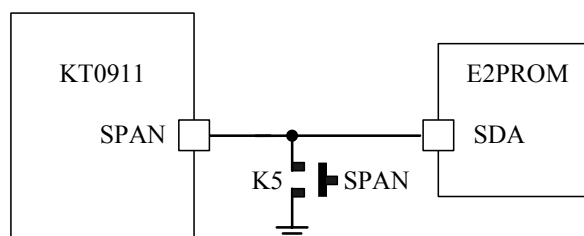

Figure 2: SPAN pin connection in key-mode

By setting register GPIO4<1:0> to 11, the AM_FM pin outputs AM/FM-SEL signal to the 3610 chip for driving LCD.

The VOL key mode is enabled by setting GPIO2<1:0> to 01. The application circuit is presented in **Figure 3**. For volume control, each time a VOLP/VOLM key is pressed, KT0911's audio volume increases/decreases by 2dB. If a VOLP/VOLM key is pressed and held, the volume will continue to increase/decrease at 2dB steps until the key is released.

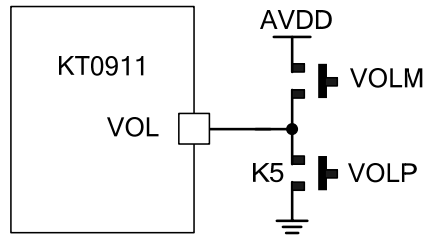

Figure 3: VOL pin connection in key-mode

The CH key mode is enabled by setting GPIO1<1:0> to 01. Figure 4 shows its connection. There are 2 key control strategies determined by register KEY_MODE<1:0>.

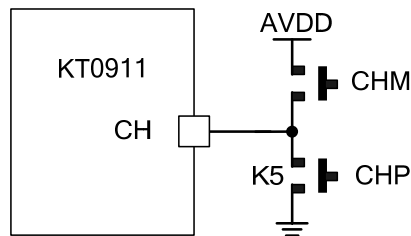

Figure 4: CH pin connection in key-mode

Mode A:

If KEY_MODE<1:0> is set to 00, Mode A is selected. In this mode, each time the CHP (CHM) is pressed, the channel frequency increases (decreases) by one step. The step sizes are defined by FMSPACE<1:0> and AMSPACE<1:0>. If the CHP (CHM) key is pressed for and held for a certain time (defined by TIME1<1:0>), the channel frequency will continue to increase (decrease) automatically at a certain pace (as defined by TIME2<2:0>) until the key is released.

Mode B:

If KEY_MODE<1:0> is set to 01, Mode B is selected. In this mode, each time the CHP (CHM) is pressed, the channel increases (decreases) by one step. The step sizes are defined by FMSPACE<1:0> and AMSPACE<1:0>. If the CHP (CHM) key is pressed and held for a specific time (TIME1<1:0>), the channel will continue to increase (decrease) automatically at a certain pace (TIME2<2:0>) even if the key is released. The movement will be stopped when the key is pressed again.

3.6.2. Dial Mode

KT0911 supports a unique Dial Mode whose application circuit is shown in Figure 10. The dial is implemented by a variable resistor with the center tap connected to the chip. KT0911 measures the ratio of two parts of the variable resistor and maps the result to the real control parameters, such as channel frequency, volume, etc.

The channel controller enters dial mode by setting register GPIO1<1:0> to 10. The illustration circuit is shown in **Figure 5**. If the center tap of the variable resistor is located in the white area, the tuned channel could be expressed as:

$$f_{tune} = \frac{X}{X+Y} (f_{top} - f_{bot} + 2 \times N_{guard} \times f_{step}) - N_{guard} \times f_{step} + f_{bot}$$

Where f_{step} is the channel step, set by register FMSPACE<1:0> or AMSPACE<1:0>, f_{top} is the upper bound of the band, f_{bot} is the lower bound of the band and N_{guard} is the number of guard channel in channel step to prevent mechanical limit of the wheels. Each band's guard number can be configured by register FM1_GUARD<6:0>, FM2_GUARD<7:0>, FM3_GUARD<7:0> and AM_GUARD<8:0>, separately. When the center tap goes in the shaded guard area, the tuned channel stays at the upper or lower bound of band.

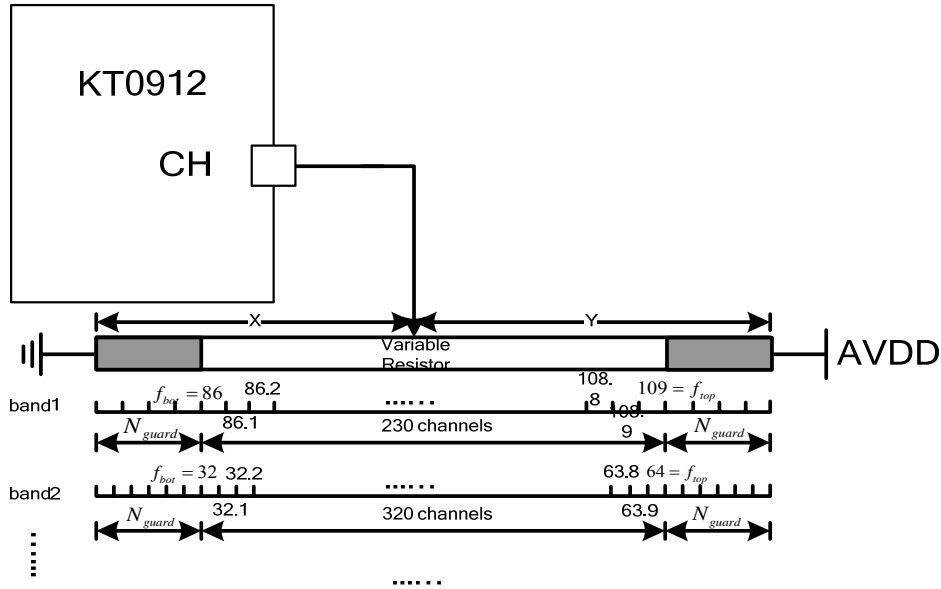

Figure 5: CH pin connection in dial-mode

The volume controller enters dial-mode by setting register GPIO2<1:0> to 10. **Figure 6** illustrates an application circuit. The actual volume set by the dial could be expressed as:

$$VOL(dBFS) = \left[\frac{X}{X+Y} (64 + N_{guard}) \right] - \frac{N_{guard}}{2} - 62$$

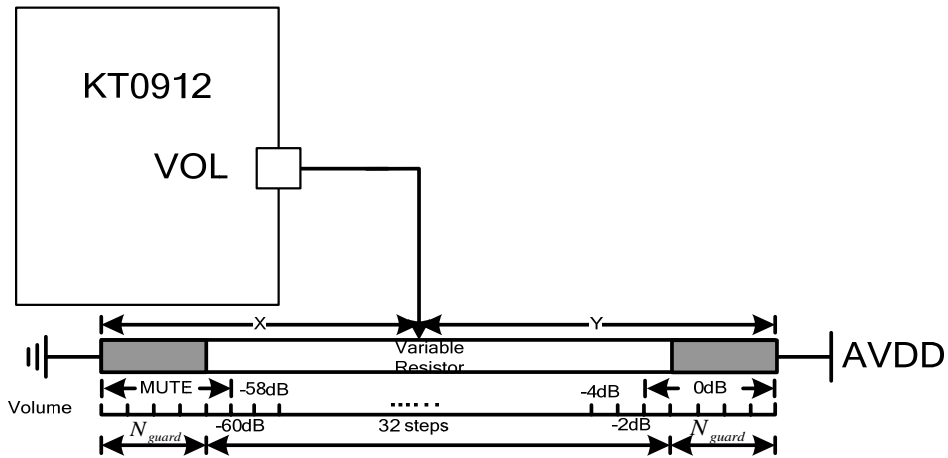

Figure 6: VOL pin connection in dial-mode

Where N_{guard} is the guard number of volume control, in 2 dB step, which can be set in register VOL_GUARD<6:0>.

The bands can be changed by band-switch in dial-mode by setting register GPIO3<1:0> to 10. The application circuit together with recommended resistor values is shown in Figure 7.

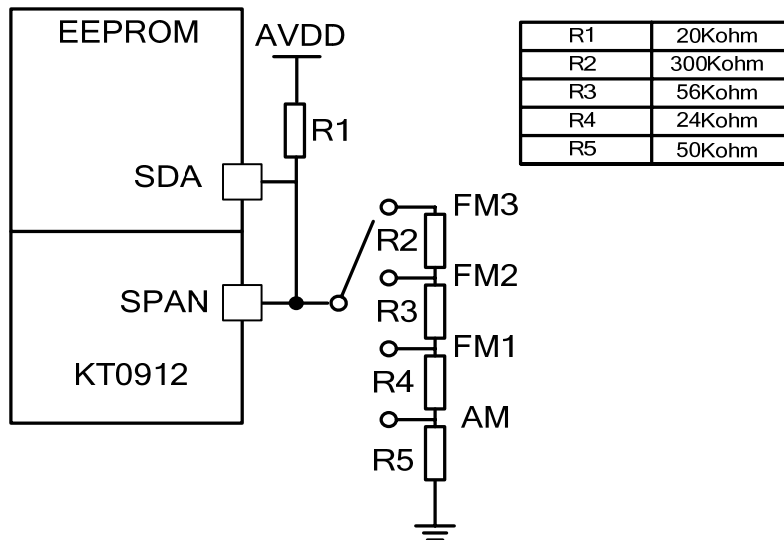

Figure 7: SPAN pin connection in dial-mode

By setting register GPIO4<1:0> to 11, the AM_FM pin outputs AM/FM-SEL signal to the 3610 chip for driving LCD.

3.6.3. Incremental Encoder Mode

KT0911 allows user to use the incremental encoder to control the channel frequency. Please refer to Figure 11 for a typical application circuit. Incremental encoder mode is enabled by setting GPIO1<1:0>, GPIO2<1:0> to 11 and GPIO3<1:0> to 01. The output pattern of the encoder for channel plus and channel minus is shown in Figure 8.

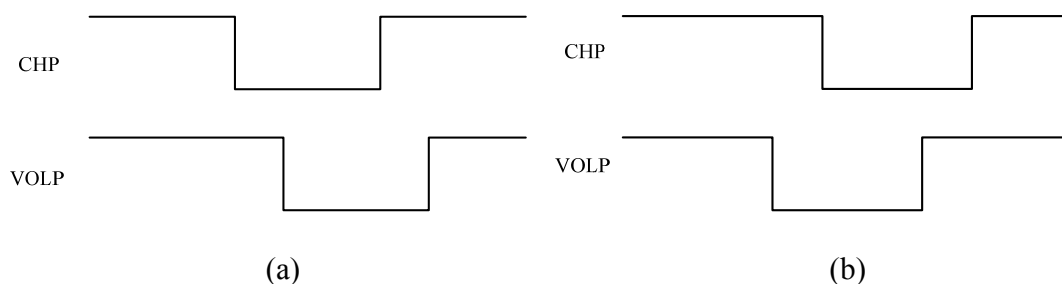

Figure 8: Incremental Encoder Mode
(a) Channel plus (b) Channel minus

Volume cannot be adjusted by KT0911 in its mode. The default volume value is set by register VOLUME<4:0>.

The band-switching is controlled by the key connected to SPAN pin, which is shown in Figure 2, when the register GPIO3<1:0> and SPAN_MODE are set to 01 and 1, respectively. Each time the SPAN key is pressed, the band of KT0911 is cycled in the following sequence, FM1→FM2→FM3→AM→FM1, where the number of FM bands and their frequency range can be adjusted by register FM_BAND_NUM<1:0> and BAND<1:0>, which is described in section 3.4.

By setting register GPIO4<1:0> to 11, the AM_FM pin outputs AM/FM-SEL signal to the 3610 chip for driving LCD.

3.7. Chip Configuration

An I2C master interface is integrated in KT0911 and can be used to initialize and operate the chip together with an external EEPROM (e.g. 24LC02). The initialization information is written into the EEPROM beforehand. When powered on, KT0911 will readout all the data stored in the EEPROM and write them into internal register bank. The mapping relationship of the register bit between KT0911 internal register bank and 24LC02 can be found in Table 6. The effective device address for EEPROM is from 000(A2:A0) to 110.

Table 6: Bit Mapping Relationship between 24LC02 and KT0911

24LC02		KT0911	
address	bits	address	bits
0x00	D7:D0	0x00	D15:D8
0x01	D7:D0		D7:D0
0x02		0x01	D15:D8
0x03			D7:D0
...
...
0x7E	D7:D0	0x3F	D15:D8
0x7F	D7:D0		D7:D0

3.8. Register Bank

Reg	Name	D15	D14	D13	D12	D11	D10	D9	D8	D7	D6	D5	D4	D3	D2	D1	D0
02h	FMSYSCFG												BAND<1:0>	FMSPACE<1:0>			
03h	FMCHAN												FMCHAN<11:0>				
04h	AUCFGA							BASS<1:0>					POP<1:0>				
05h	AUCFGB	MONO				DE		BLNDADJ<1:0>				DBLND					
0Ah	LOCFG							AFCD									
0Fh	VOLUME													VOLUME<4:0>			
16h	AMSYSCFG									AU_GAIN<1:0>							AFCD_AM
17h	AMCHAN												AMCHAN<10:0>				
1Dh	GPIO									GPI04<1:0>			GPI03<1:0>	GPI02<1:0>		GPI01<1:0>	
22	AMDSP									AM_BW<1:0>			AM_GAIN<1:0>	INV_LEFT_AUDIO			
33h	AMCFGA		AM_SPACE<1:0>										KEY_MODE<1:0>	SPAN_MODE			FM_BAND_NUM<1:0>
34h	AMCFGB												TIME1<1:0>	TIME2<2:0>			
38h	CHANGUARDA				FM1_GUARD<6:0>								AM_GUARD<8:0>				
39h	CHANGUARDB				FM2_GUARD<7:0>								FM3_GUARD<7:0>				
3Ah	VOLGUARD				VOL_GUARD<6:0>												

3.8.1. FMSYSCFG (Address 0x02)

Bit	Symbol	Access	Default	Functional Description
15:6	Reserved	RW	00 0000 0000	Reserved
5:4	BAND<1:0>	RW	00	FM band selection, only effective when FM_BAND_NUM<1:0> is set to 01. 00 = 86MHz ~109MHz(FM1) 01 = 64MHz ~ 91MHz(FM2) 10 = 32MHz ~ 64MHz(FM3) 11 = Reserved
3:2	FMSPACE<1:0>	RW	01	FM channel spacing 00 = 200KHz 01 = 100KHz 10 = 50KHz
1:0	Reserved	RW	11	Reserved

3.8.2. FMCHAN (Address 0x03)

Bit	Symbol	Access	Default	Functional Description
15:12	Reserved	RW	0000	Reserved
11:0	FMCHAN<11:0>	RW	0110_1011_1000 (0x06B8)	Initial FM channel for key mode or incremental encoder mode. FMCHAN<11:0>=Frequency (KHz) / 50KHz. For example, if desired channel is 86MHz, then the CHAN<11:0> should be 0x06B8.

3.8.3. AUCFGA (Address 0x04)

Bit	Symbol	Access	Default	Functional Description
15:10	Reserved	RW	00	Reserved
9:8	BASS<1:0>	RW	00	Bass boost control 00 = Disable 01 = Weak 10 = Middle 11 = Strong
7:6	Reserved	RW	10	Reserved
5:4	POP<1:0>	RW	00	Audio DAC anti-pop configuration

				00 : 100uF AC-coupling capacitor 01 : 60uF AC-coupling capacitor 10 : 20uF AC-coupling capacitor 11 : 10uF AC-coupling capacitor
3:0	Reserved	RW	0010	Reserved

3.8.4. AUCFGB (Address 0x05)

Bit	Symbol	Access	Default	Functional Description
15	MONO	RW	0	Mono select 0 = Stereo 1 = Force mono Note that if both MONO bit and INV_AUDIO_LEFT are set to 1, a fully differential audio signal can be sent from LOUT and ROUT pin.
14:12	Reserved	RW	000	Reserved
11	DE	RW	0	De-emphasis time constant selection 0 = 75us 1 = 50us
10	Reserved	RW	0	Reserved
9:8	BLNDADJ<1:0>	RW	00	Stereo/Mono blend level adjustment 00 = High 01 = Highest 10 = Lowest 11 = Low
7:6	Reserved	RW	0	Reserved
5	DBLND	RW	0	Blend disable 0 = Blend enable 1 = Blend disable
4:0	Reserved	RW	0_0000	Reserved

3.8.5. LOCFG (Address 0x0A)

Bit	Symbol	Access	Default	Functional Description
15:9	Reserved	RW	0000_010	Reserved
8	FMAFCD	RW	1	AFC disable control bit 0 = AFC enable 1 = AFC disable
7:0	Reserved	RW	0000_0000	Reserved

3.8.6. VOLUME (Address 0x0F)

Bit	Symbol	Access	Default	Functional Description
15:12	Reserved	RW	1000	Reserved
11:5	Reserved	RW	100_0000	Reserved
4:0	VOLUME<4:0>	RW	1_1111	Default volume in key mode or encoder mode. 11111 = 0dB 11110 = -2dB 11101 = -4dB 00010 = -58dB 00001 = -60dB 00000 = Mute

3.8.7. AMSYSCFG (Address 0x16)

Bit	Symbol	Access	Default	Functional Description
15:8	Reserved	RW	0000_0000	Reserved
7:6	AU_GAIN<1:0>	RW	00	Audio gain selection 01 : 6dB 00 : 3dB 11 : 0dB 10 : -3dB
5:1	Reserved	RW	0_0001	Reserved
0	AMAFCD	RW	0	AFC disable control in AM mode 0 = Enable 1 = Disable

3.8.8. AMCHAN (Address 0x17)

Bit	Symbol	Access	Default	Functional Description
15:11	Reserved	RW	00000	Reserved
10:0	AMCHAN<10:0>	RW	001_1111_1000 (0x01F8)	Initial AM Channel for key mode and incremental encoder mode. AMCHAN<10:0> = Frequency(in KHz)

3.8.9. GPIOCFG (Address 0x1D)

Bit	Symbol	Access	Default	Functional Description
-----	--------	--------	---------	------------------------

15:8	Reserved	RW	0000_0110	Reserved
7:6	GPIO4<1:0>	RW	01	AM_FM pin mode selection 00 = Reserved. 01 = Key mode. 10 = Switch mode. 11 = Output mode.
5:4	GPIO3<1:0>	RW	01	SPAN pin mode selection 00 = Reserved 01 = Key mode 10 = Dial mode 11 = Reserved
3:2	GPIO2<1:0>	RW	01	VOL pin mode selection 00 = High Z 01 = Key mode 10 = Dial mode 11 = Reserved
1:0	GPIO1<1:0>	RW	01	CH pin mode selection 00 = High Z 01 = Key mode. 10 = Dial mode. 11 = Reserved

3.8.10. AMDSP (Address 0x22)

Bit	Symbol	Access	Default	Functional Description
15:8	Reserved	RW	1010_0010	Reserved
7:6	AM_BW<1:0>	RW	01	AM channel bandwidth selection 00 = 2KHz 01 = 2KHz 10 = 4KHz 11 = 6KHz
5:4	AM_GAIN<1:0>	RW	00	AM audio gain setting 00 = 6dB 01 = 9dB 10 = 12dB 11 = 3dB
3	INV_LEFT_AUDIO	RW	0	Left channel inverse control 0 : Normal operation 1: Inversing the left channel audio signal. A fully differential audio signal can be got from LOUT and ROUT if both of the INV_LEFT_AUDIO bit and MONO bit are set to 1.

2:0	Reserved	RW	100	Reserved
-----	----------	----	-----	-----------------

3.8.11. AMCFGA (Address 0x33)

Bit	Symbol	Access	Default	Functional Description
15:14	AMSPACE<1:0>	RW	00	AM channel space selection 00 : 1KHz 01 : 9KHz 10 : 10KHz 11 : 10KHz
13:7	Reserved	RW	01_0100_0	Reserved
6:5	KEY_MODE<1:0>	RW	00	Working mode selection when key mode is selected. 00 = Working mode A 01 = Working mode B Others = Reserved For detailed information about working mode A and working mode B, please refer to section 3.6.1
5:2	Reserved	RW	000	Reserved
1:0	FM_BAND_NUM<1:0>	RW	01	FM band number selection 00 : Reserved 01 : 1 FM band (The freq range is determined by BAND<1:0>) 10 : 2 FM bands (FM1 and FM2) 11 : 3 FM bands (FM1, FM2, FM3)

3.8.12. AMCFGB (Address 0x34h)

Bit	Symbol	Access	Default	Functional Description
15:6	Reserved	RW	0100_0000_00	Reserved
5:4	TIME1<1:0>	RW	01	TIME1, parameter used in key mode 00 = Shortest 11 = Longest
3:1	TIME2<2:0>	RW	000	TIME2, parameter used in key mode 000 = Fastest

				111 = Slowest
0	Reserved	RW	0	Reserved

3.8.13. CHANGUARDA (Address 0x38h)

Bit	Symbol	Access	Default	Functional Description
15:9	FM1_GUARD<6:0>	RW	000_0011	FM1 band channel guard number in dial mode
8:0	AM_GUARD<8:0>	RW	0_0000_0011	AM band channel guard number in dial mode

3.8.14. CHANGUARDB (Address 0x39h)

Bit	Symbol	Access	Default	Functional Description
15:8	FM2_GUARD<7:0>	RW	0000_0011	FM2 band channel guard number in dial mode
7:0	FM3_GUARD<7:0>	RW	0000_0011	FM3 band channel guard number in dial mode

3.8.15. VOLGUARD (Address 0x3Ah)

Bit	Symbol	Access	Default	Functional Description
15	Reserved	RW	0	Reserved
14:8	VOL_GUARD<7:0>	RW	000_0001	Volume guard number in dial mode
7:0	Reserved	RW	0	Reserved

Table 7: KT0911 Internal Register Default Value

Address	Default	Address	Default	Address	Default	Address	Default
0x00	0x8204	0x10	0x0000	0x20	0x0000	0x30	0x0078
0x01	0x4B54	0x11	0x0801	0x21	0x0100	0x31	0x01F4
0x02	0x0007	0x12	0x0000	0x22	0xA244	0x32	0xF3F4
0x03	0x06B8	0x13	0x0000	0x23	0x1C00	0x33	0x1401
0x04	0xC082	0x14	0x0000	0x24	0x0000	0x34	0x4010
0x05	0x0000	0x15	0x0000	0x25	0x0000	0x35	0x0000
0x06	0xAA00	0x16	0x0002	0x26	0x0000	0x36	0x0000
0x07	0x0065	0x17	0x01F8	0x27	0x0000	0x37	0x0000
0x08	0x0000	0x18	0x3FEF	0x28	0x0000	0x38	0x0603
0x09	0x0500	0x19	0x7000	0x29	0x0000	0x39	0x0303
0x0A	0x0500	0x1A	0x0032	0x2A	0x0000	0x3A	0x0100
0x0B	0x0000	0x1B	0x0442	0x2B	0x0000	0x3B	0x0270
0x0C	0x0020	0x1C	0x0025	0x2C	0x0000	0x3C	0x0000
0x0D	0x1401	0x1D	0x06EA	0x2D	0x0000	0x3D	0x0000
0x0E	0x1130	0x1E	0x0001	0x2E	0x0010	0x3E	0xFFFF
0x0F	0x881F	0x1F	0x0001	0x2F	0x08FC	0x3F	0x0102

4. Typical Application Circuit

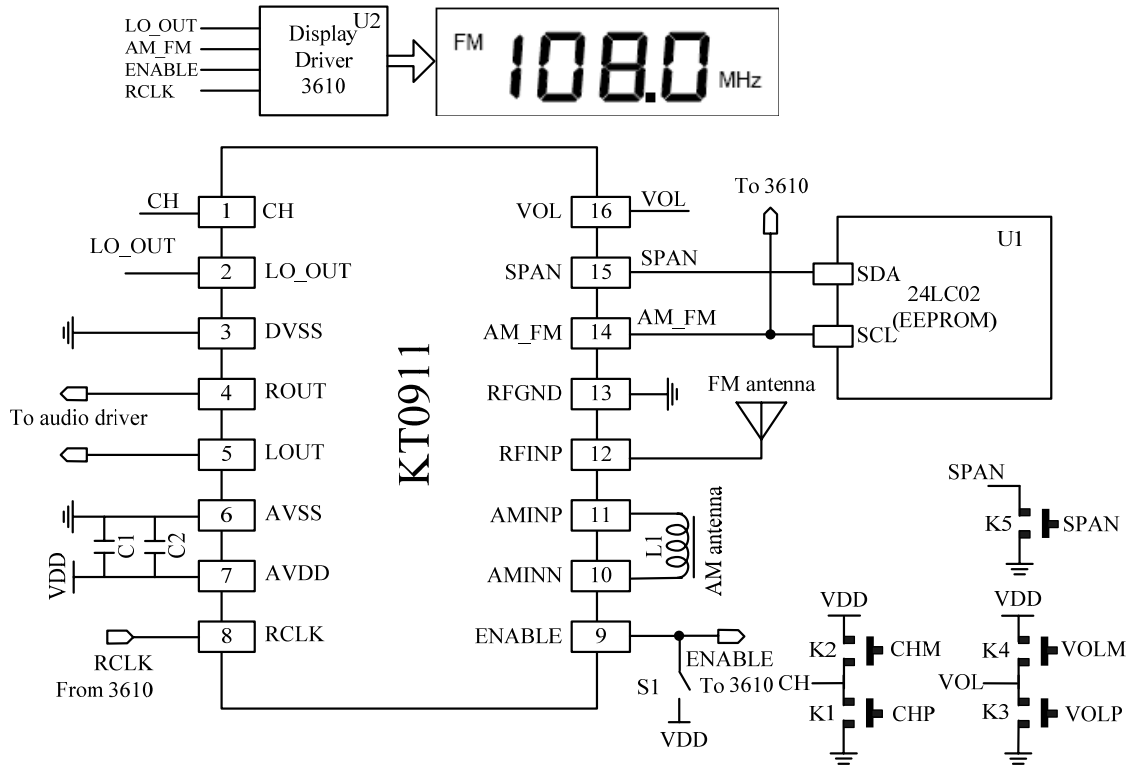

Figure 9: Typical application circuits for key mode

Components	Description	Value/Supplier
C1,C2	Supply decoupling capacitor	C1=10uF C2=0.1uF
L1	AM ferrite antenna	350uH
S1	Switch	
K1~K5	Key/buttons	
U1	EEPROM	24LC02
U2	Display driver	3610

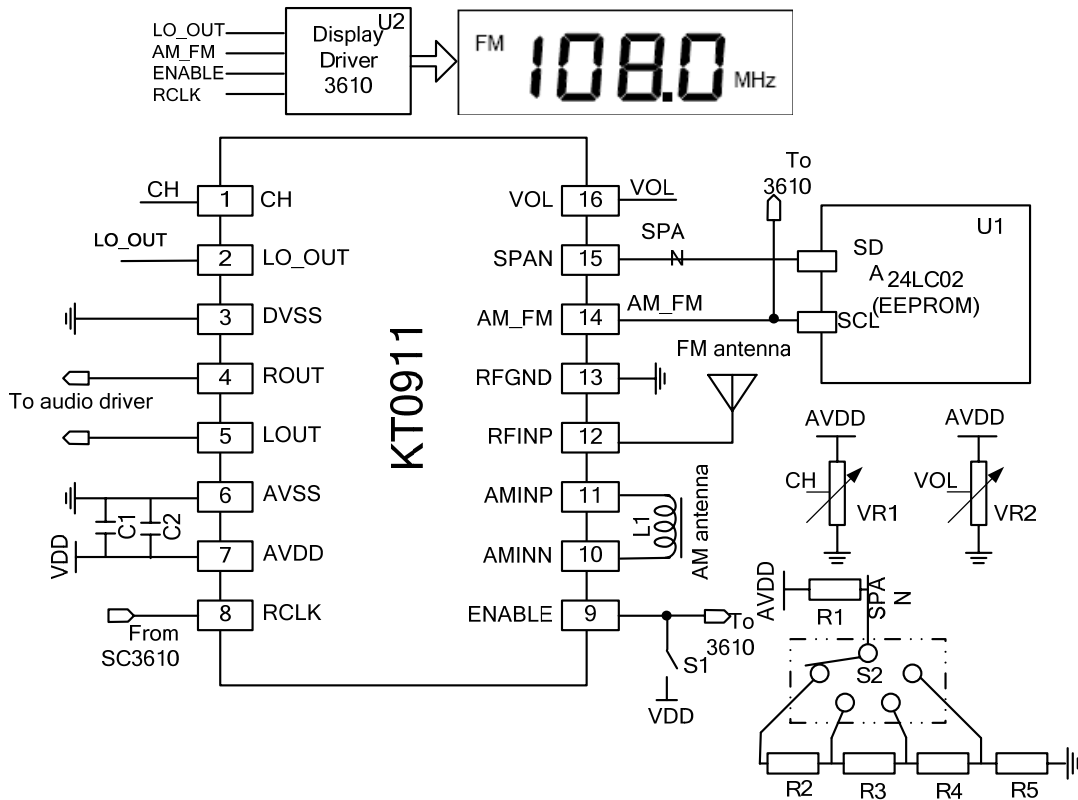

Figure 10: Typical application circuits for dial mode

Components	Description	Value/Suppliers
C1,C2	Supply decoupling capacitor	C1=10uF C2=0.1uF
L1	AM ferrite antenna	350uH
S1	Single-pole/Double-Throw switch	
S2	Single-pole/Fourth-Throw switch	
VR1,VR2	Variable resistor	
R1~R5	Resistor ladder for band switching	R1=20kohm R2=300kohm R3=56kohm R4=24kohm R5=50kohm
U1	EEPROM	24LC02
U2	Display driver	SC3610

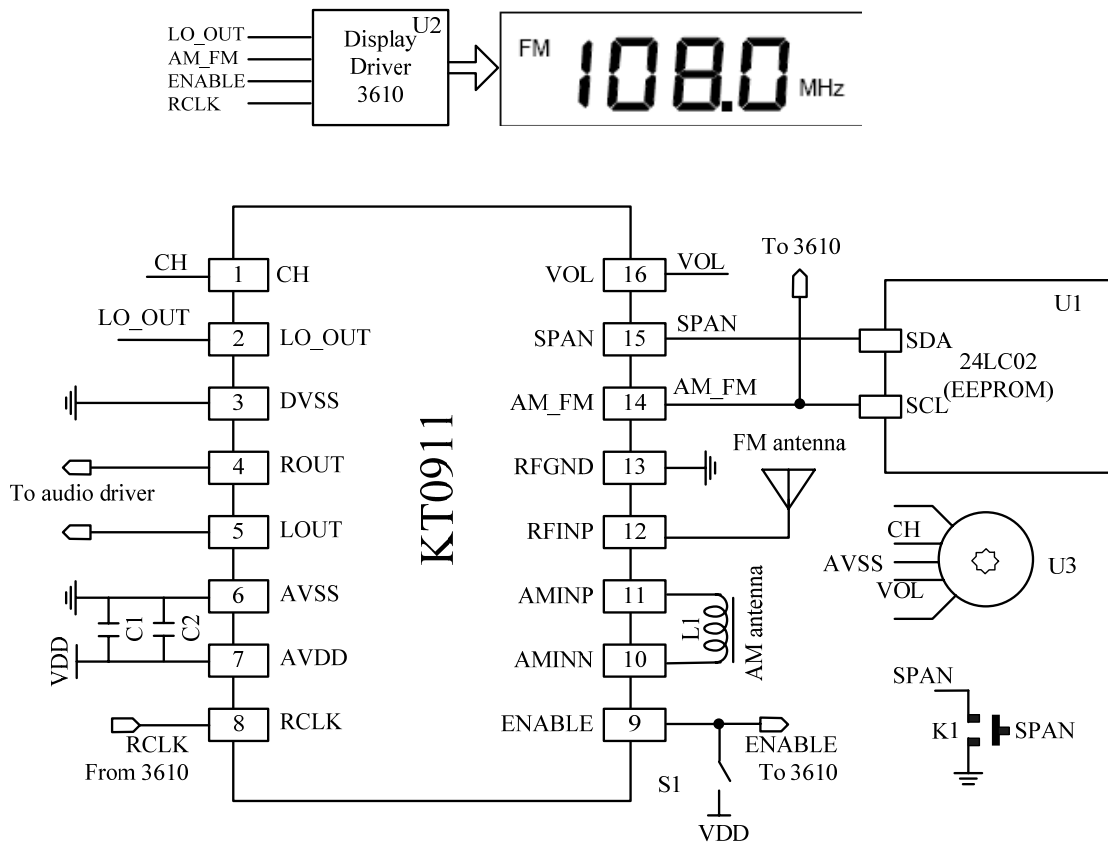

Figure 11: Typical application circuits for incremental encoder mode

Components	Description	Value/Suppliers
C1,C2	Supply decoupling capacitor	C1=10uF C2=0.1uF
L1	AM ferrite antenna	350uH
S1	Switch	
K1	Key-press	
U1	EEPROM	24LC02
U2	Display driver	SC3610
U3	Incremental encoder	

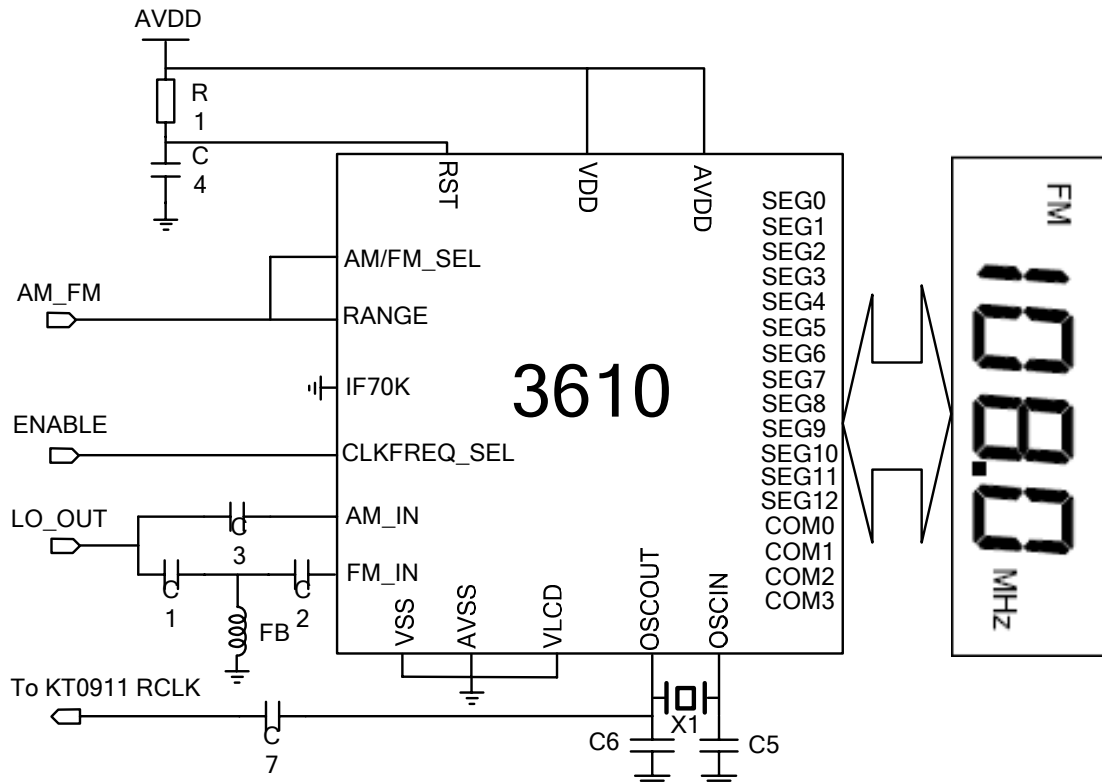
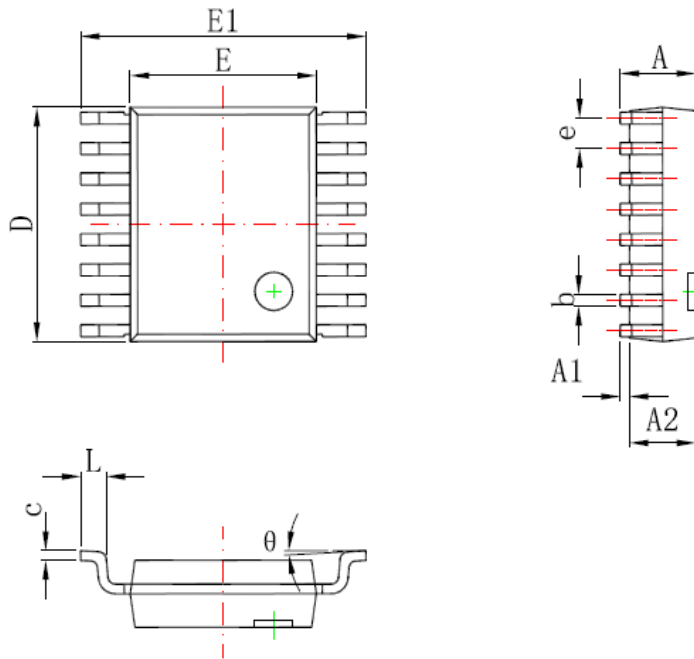

Figure 12. Application circuits for 3610 display driver

Components	Description	Value/Suppliers
C1,C2,FB	FM AC decoupling network.	C1=200pF C2=200pF FB=300ohm @ 100MHz
C3	AM AC decoupling capacitor	C3=2pF
R1, C4	Chip reset network	R1=1Mohm C4=0.1uF
C5,C6	Crystal oscillator load capacitor	C5=C6=24pF
C7	Reference clock AC decoupling capacitor	C7=1nF
L1	AM ferrite antenna	350uH
S1	Switch	

Package Outline



Symbol	Dimensions In Millimeters		Dimensions In Inches	
	Min	Max	Min	Max
A	1.350	1.750	0.053	0.069
A1	0.100	0.250	0.004	0.010
A2	1.350	1.550	0.053	0.061
b	0.200	0.300	0.008	0.012
c	0.170	0.250	0.007	0.010
D	4.700	5.100	0.185	0.200
E	3.800	4.000	0.150	0.157
E1	5.800	6.200	0.228	0.244
e	0.635 (BSC)		0.025 (BSC)	
L	0.400	1.270	0.016	0.050
θ	0°	8°	0°	8°

5. Revision History

- V1.0 Official Release.
- V1.1 Modify the register map.
 - Modify the default value table.
 - Add some new register bits.
- V1.2 Modify Table 1, Table 3 and Table 4.

6. Contact Information

KT Micro, Inc.

22391 Gilberto, Suite D
Rancho Santa Margarita, CA 92688
USA
Tel: 949-713-4000
Fax: 949-713-4004
Email: sales@ktmicro.com

北京昆腾微电子有限公司

北京市海淀区蓝靛厂东路 2 号金源时代商务中心
2 号楼 B 座 8 层 (100097)
电话: 8610-88891955
传真: 8610-88891977
电子邮件: sales@ktmicro.com
网站: <http://www.ktmicro.com.cn>