



KTMicro

Monolithic Digital FM/MW/SW/LW Receiver Radio-on-a-Chip™

KT0915

■ Features

Worldwide full band FM/MW/SW/LW support

FM: 32MHz-110MHz

MW: 500KHz-1710KHz

SW: 1.6MHz~32MHz

LW: 150KHz ~ 280KHz

Fully integrated frequency synthesizer with no external components

High Sensitivity

1.6uVEMF for FM

16uVEMF for AM

High Fidelity

SNR (FM/AM): 60dB/55dB

THD: 0.3%

Low Supply Current

22mA (operating)

<15uA (standby)

Advanced features

Automatic antenna tuning

Adjustable AM channel filters (2k/4k/6KHz)

Automatic Frequency Control (AFC)

Automatic Gain Control (AGC)

Embedded FM SNR meter

Fast seek/Tune

Integrated stereo headphone driver

I2C control interface for MCU

Special Features:

Support traditional dial and digital key for frequency tuning and volume control

Memorize channel and volume in standby mode

Low supply voltage: 2.2V to 3.6V, can be supplied by 2 AAA batteries

Support both 32.768KHz and 38KHz crystal

Support continuous reference frequency from 32.768KHz to 26MHz

Small form factor SSOP16L package

RoHS Compliant

■ Applications

Desktop and portable radio, mini/portable audio systems, clock radio, campus radio, PMP docking station, car audio system, toy and gift.

Rev. 0.22

Information furnished by KT Micro is believed to be accurate and reliable. However, no responsibility is assumed by KT Micro for its use, nor for any infringements of patents or other rights of third parties which may result from its use. No license is granted by implication or otherwise under any patent or patent rights of KT Micro, Inc.

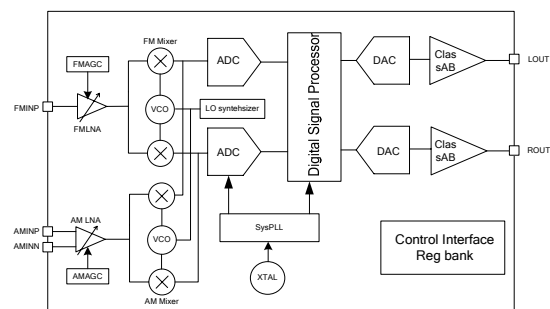

KT0915 System Diagram

■ Description

The KT0915 is a fully integrated full band AM/FM digital radio receiver IC with patented technologies that offer full band FM/MW/SW/LW functionality, high quality audio performance, simple design and low BOM cost. The direct frequency and volume control interface help customers to maintain the classic looks of their existing products.

Thanks to the patented tuning technology, the receiver maintains good signal reception with short antenna. The chip consumes only 22mA current and can be powered by 2 AAA batteries. Another useful feature is that the volume and channel setup can be preserved in standby mode without external memories. KT0915 supports a wide range of reference clocks from 32.768KHz to 26MHz, hence can share system clocks with a varieties of MCUs further reducing the system BOM cost.

With high audio performance, fully integrated features and low BOM cost, KT0915 is ideal for various FM/MW/SW/LW applications and products.

Table of Content

1. Electrical Specification.....	4
2. Pin List	6
3. Function Description	7
3.1. Overview	7
3.2. FM Receiver.....	7
3.3. AM Receiver	7
3.4. Operation Bands.....	7
3.5. Standby	7
3.6. Crystal and reference clock.....	8
3.7. User-Machine Interface	8
3.7.1. Key Mode.....	8
3.7.2. Dial Mode.....	9
3.7.3. Programmable Band.....	9
3.8. Digital Signal Processing	10
3.8.1. FM Stereo Decoder	10
3.8.2. Mute / Softmute.....	11
3.8.3. Stereo / Mono Blending	11
3.8.4. Bass	11
3.8.5. Stereo DAC, Audio Filter and Driver.....	11
3.8.6. AM Bandwidth.....	11
3.8.7. TUNE	12
3.8.8. SEEK.....	12
3.9. I2C Control Interface	12
3.10. Register Bank	14
3.10.1. CHIP ID (Address 0x01).....	15
3.10.2. SEEK (Address 0x02)	15
3.10.3. TUNE (Address 0x03).....	15
3.10.4. VOLUME (Address 0x04).....	15
3.10.5. DSPCFG (Address 0x05).....	16
3.10.6. LOCFG (Address 0x0A).....	17
3.10.7. LOCFG (Address 0x0C).....	17
3.10.8. RXCFG (Address 0x0F).....	17
3.10.9. STATUSA (Address 0x12).....	18
3.10.10. STATUSB (Address 0x13)	18
3.10.11. STATUSC (Address 0x14)	18
3.10.12. AMSYSCFG (Address 0x16).....	19
3.10.13. AMCHAN (Address 0x17)	20
3.10.14. AMCALI (Address 0x18)	20
3.10.15. GPIOCFG (Address 0x1D)	20
3.10.16. AMDSP (Address 0x22)	20
3.10.17. AMSTATUSA (Address 0x24).....	21
3.10.18. AMSTATUSB (Address 0x25).....	21
3.10.19. SOFTMUTE (Address 0x2Eh).....	21
3.10.20. USERSTARTCH (Address 0x2F).....	22
3.10.21. USERGUARD (Address 0x30).....	22
3.10.22. USERCHANNUM (Address 0x31)	22
3.10.23. AMCFG (Address 0x33).....	23
3.10.24. AMCFG2 (Address 0x34h)	23
3.10.25. AFC (Address 0x3Ch).....	23
4. Typical Application Circuit.....	24
5. Package Outline.....	25
6. Order Information.....	26
7. Revision History	26



8. Contact Information.....27

1. Electrical Specification

Table 1: Operation Condition

Parameter	Symbol	Operating Condition	Min	Typ	Max	Units
Power Supply	VDD	Relative to Vss	2.1	3.3	3.6	V
Operating Temp	Ta	Ambient Temperature	-30	25	70	°C

Table 2: DC Characteristics

Parameter	Symbol	Test/Operating Condition	Min	Typ	Max	Units
Current Consumption	FM Mode	I _{FM}	-	21.3	-	mA
	AM Mode	I _{AM}		22		mA
Standby Current	I _{APD}			14.5		μA

Table 3: FM Receiver Characteristics

(Unless otherwise noted Ta = -30~70°C, AVDD= 2.1V to 3.6V)

Parameter	Symbol	Test/Operating Condition	Min	Typ	Max	Units
FM Frequency Range	F _{rx}		32		110	MHz
Sensitivity ^{1,2,3}	Sen	(S+N)/N=26dB		1.6	2	uVemf
Input referred 3 rd Order Intermodulation Production ^{4,5}	IIP3			85		dBuVE MF
Adjacent Channel Selectivity		±200KHz	35		51	dB
Alternate Channel Selectivity		±400KHz	50		70	dB
Image Rejection Ratio				35		dB
AM suppression				50		dB
RCLK frequency			32.768	32.768	26000	KHz
RCLK frequency Range ⁸			-100		100	ppm
Audio Output Voltage ^{1,2,3,4}		32ohm load	90	100	110	mV _{RMS}
Audio Band Limits ^{1,2,4}		±3dB	30		15k	Hz
Audio Stereo Separation ^{1,4,6}			35			dB
Audio Mono S/N ^{1,2,3,4}			55	60		dB
Audio Stereo S/N ^{1,4,6,7}		DBLND=1		64		dB
Audio THD ^{1,2,4,6}				0.3		%
	De-emphasis Time Constant	DE=0		75		μs
DE=1				50		μs
Audio Common Mode Voltage				0.85		V
Audio Output Load Resistance	R _L	Single-ended		32		Ω
Seek/Tune Time					50	ms
Power-up Time					600	ms

Notes:

1. F_{MOD}=1KHz, 75us de-emphasis
2. MONO=1
3. ΔF=22.5KHz
4. V_{EMF}=1mV, F_{rx}=32MHz~110MHz
5. AGCD=1
6. ΔF=75KHz
7. VOLUME<4:0>=11111
8. The supported RCLK frequency is not continuous. Please refer to application notes.

Table 4: LW/MW/SW Receiver Characteristics
(Unless otherwise noted Ta = -30~70°C, AVDD= 2.1V to 3.6V)

Parameter	Symbol	Test/Operating Condition	Min	Typ	Max	Units
AM Frequency Range	F _{rx}		150		32000	KHz
Sensitivity ^{1,2}	Sen	(S+N)/N=26dB		15		uVemf
Audio Output Voltage ^{1,2,3,4}		32ohm load		60		mV _{RMS}
Audio Mono S/N ^{1,2,3,4}				55		dB
Audio THD ^{1,2,4,6}				0.3	0.6	%
Antenna inductance	L1		280	350	420	uH
	L2			2800		uH

Notes:

1. F_{MOD}=1KHz
2. Modulation index is 30%
3. V_{EMF}=1mV, LW Frequency=150KHz ~ 280KHz, MW Frequency =500KHz~1710KHz, SW Frequency =1.6MHz~32MHz
4. VOLUME<4:0>=11111

2. Pin List

Table 5: Pin list

Pin Num	Pin Name	Description
1	CH	Channel adjustment
2	DVSS	Digital ground.
3	ROUT	Right channel audio output.
4	LOUT	Left channel audio output.
5	AVSS	Analog ground.
6	AVDD	Power supply
7	XI/RCLK	Crystal input/Reference clock input
8	XO	Crystal output
9	ENABLE	Chip enable. Tied to an internal 600kohm pull down resistor
10	AMINN	AM RF negative input.
11	AMINP	AM RF positive input.
12	RFINP	FM RF input
13	RFGND	RF ground.
14	SCL	SCL of I2C interface. Tied to an internal 47kohm pull-up resistor.
15	SDA	SDA of I2C interface. Tied to an internal 47kohm pull-up resistor.
16	VOL	Volume adjustment

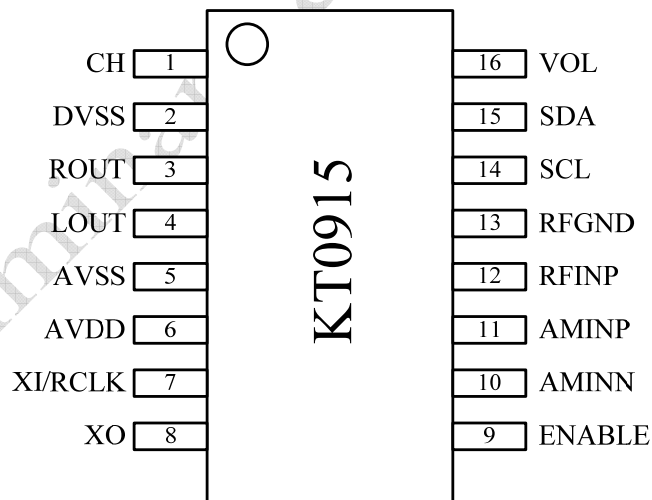
Figure 1: KT0915 Pin assignment (Top view)

3. Function Description

3.1. Overview

KT0915 offers a true single-chip, versatile and full-band FM/MW/SW/LW radio solution by minimizing the external components and offering a variety of configurations.

3.2. FM Receiver

The FM receiver is based on the architecture of KT Micro's latest generation FM receiver chips in mass production. There are no external filters or frequency-tuning devices thanks to a proprietary digital low-IF architecture consisting of a fully-integrated LNA, an automatic gain control (AGC), a set of high-performance ADCs, high-quality analog and digital filters, and an on-chip low-noise self-tuning VCO. The on-chip high-fidelity Class-AB driver further eliminates the need for external audio amplifiers and can drive stereo headphones directly.

3.3. AM Receiver

The AM Receiver employs a similar digital low IF architecture and share many circuits with the FM receiver. The AM receiver supports a wide band from 150KHz to 32MHz covering LW, MW and SW bands. The AM channel spacing can be set to 1KHz, 9KHz or 10KHz to address different applications. The bandwidth of the channel filter can be set to 2KHz, 4KHz or 6KHz to suit various requirements.

The AM receiver in KT0915 can provide accurate and automatic AM tuning without manual alignment. It supports 350uH ferrite loop antenna with +/- 25% tolerance for MW band and 2800uH for LW band.

3.4. Operation Bands

KT0915 supports wide FM bands and AM bands. The FM receiver covers frequencies from 32MHz to 110MHz. The 32MHz to 64MHz is defined as Campus Band in KT0915 and can be enabled by setting CAMPUSBAND_EN register to 1. The AM receiver covers MW, SW and LW bands. In MW mode, the band is from 500KHz to 1710KHz. In SW mode, the band is from 1.6MHz to 32MHz. In LW mode, the band is from 150KHz to 280KHz.

3.5. Standby

KT0915 supports both Software Standby mode and Hardware Standby mode. To enter Software Standby, the STANDBT register shall be set to 1 through I2C interface. To enter Hardware Standby, the ENABLE pin is pulled down to ground. In the standby modes, the internal state (channel, volume) is preserved and can be recovered when the chip wakes up from the standby.

3.6. Crystal and reference clock

KT0915 integrates a low frequency crystal oscillator that supports 32.768KHz and 38KHz crystals. Alternatively a CMOS level external reference clock may be used by setting the RCLK_EN register to 1 and setting REFCLK<3:0> according to the frequency of the reference clock.

3.7. User-Machine Interface

KT0915 offers multiple user-machine interface options including I2C /MCU Interface, Key Mode and Dial Mode.

3.7.1. Key Mode

KT0915 allows user to control the channel and volume by using keys/buttons to send digital control signals to CH and VOL pins. Please refer to Section 4 for a typical application circuit. The key mode is enabled by setting GPIO1<1:0> and GPIO2<1:0> to 01.

Each time VOLP/VOLM key is pressed, the volume increases/decreases by 2dB. If the VOLP/VOLM key is pressed and held, the volume will continue to increase/decrease at 2dB steps until the key is released.

When configured in Key Mode, KT0915's channel selection has two working modes.

Mode A:

If KEY_MODE<1:0> is set to 00, Mode A is selected. In this mode, each time the CHP (CHM) is pressed, the channel frequency increases (decreases) by one step. The step sizes are defined by FMSPACE<1:0> and AMSPACE<1:0>. If the CHP (CHM) key is pressed for and held for a certain time (defined by TIME1<1:0>), the channel frequency will continue to increase (decrease) automatically at a certain pace (as defined by TIME2<2:0>) until the key is released.

Mode B:

If KEY_MODE<1:0> is set to 01, Mode B is selected. In this mode, each time the CHP (CHM) is pressed, the channel increases (decreases) by one step. The step sizes are defined by FMSPACE<1:0> and AMSPACE<1:0>. If the CHP (CHM) key is pressed and held for a specific time (TIME1<1:0>), the channel will continue to increase (decrease) automatically at a certain pace (TIME2<2:0>) even if the key is released. The movement is stopped when the key is pressed again.

3.7.2. Dial Mode

KT0915 supports a unique Dial Mode (mechanical tuning wheel with a variable resistor) which is enabled by setting GPIO1<1:0> and GPIO2<1:0> to 10. The dial can be a variable resistor with the tap connected to CH / VOL as shown in Figure 2. The divided voltage at the tap is digitized by an internal high resolution analog to digital converter (ADC) and translated into a channel code or volume level.

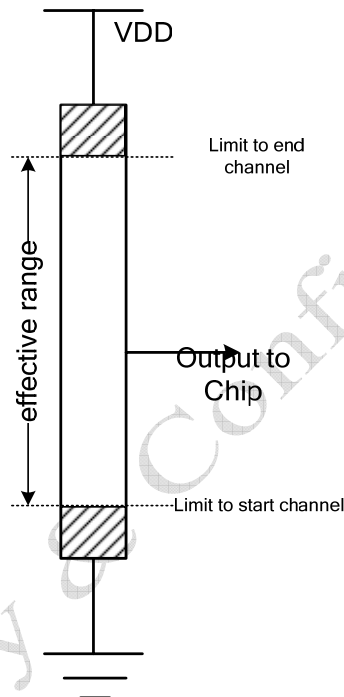

Figure 2 Range of the variable resistor

The channel index is programmable and the start point is defined by USER_GUARD<8:0>. For illustration purpose only, assuming a resistor ladder ADC has 600 linear segments and there are maximum 500 channels in the desired band, the user can define the start point to be 50 and the first channel will then start from the 50th segment, as shown in Figure 2. This feature is desirable when variation in the external variable resistor exists.

3.7.3. Programmable Band

KT0915 supports programmable FM, AM bands when Dial Mode is selected. This feature is enabled by setting USERBAND to 1. The number of channels, start channel and start number are defined in USER_CHAN_NUM<11:0>, USER_START_CHAN<14:0> and USER_GUARD<8:0> .

For example, if an user wants to define a FM band with frequency range from 86MHz to 109MHz with 100KHz step, an AM band with frequency range from 504 to 1710KHz with 9KHz step Assuming a 100kohm external variable resistor is used as the dial and the user wants to exclude 10kohm on both ends limiting the effective range to 80kohm. The setup shall be as follows:

FM mode, USER_CHAN_NUM<14:0> = 0x00E7 (231 channels),
 USER_START_CHAN<14:0> = 0x06B8 (86MHz) and USER_GUARD<8:0> = 0x001D
 (29, i.e. 10kohm is the start point).

When the band is switched to AM mode,
 USER_CHAN_NUM<14:0> = 0x00E7 (135 channels), USER_START_CHAN<14:0> =
 0x0087(504KHz) and USER_GUARD<8:0> = 0x0011(17).

3.8. Digital Signal Processing

3.8.1. FM Stereo Decoder

The digitized IF signal is fed to the FM demodulator which demodulates the signal and outputs a digital multiplexed (MPX) signal consisting of L+R audio, L-R audio, 19KHz pilot tone and RDS signal. The left channel signal and the right channel signal can be extracted from the MPX signal by simply adding and subtracting the L+R signal and L-R signal. The spectrum diagram is shown in Figure 3.

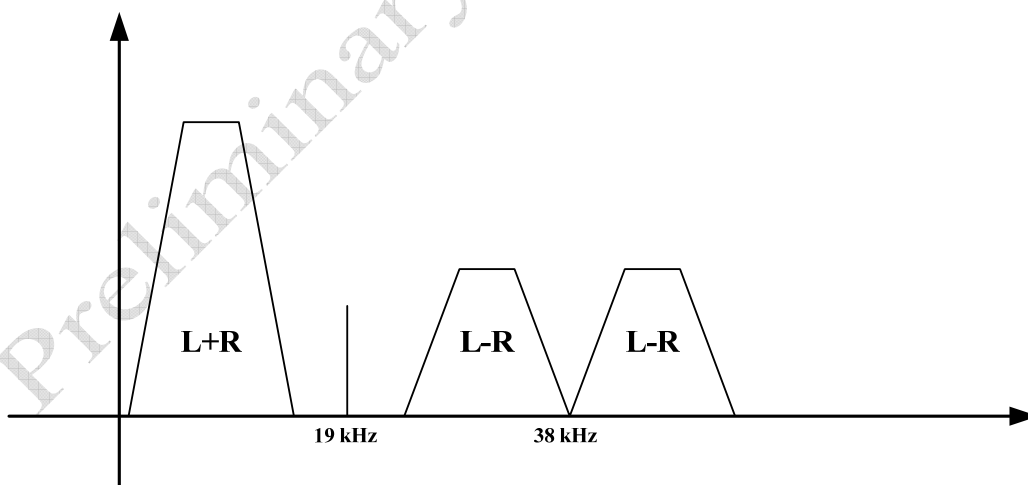

Figure 3: Spectrum diagram of the MPX signal

3.8.2. Mute / Softmute

KT0915 can be hard muted by setting DMUTE to 0 and the output of the audio signal is set to the common mode voltage.

There is also a Soft Mute feature that is enabled by setting FMDSMUTE to 0 in FM mode and AMDSMUTE to 0 in AM mode. In this mode, the audio volume is gradually attenuated when the signal reception is bad (i.e. when the RSSI is below a certain level as defined by FM_SMTH<2:0> and AM_SMTH<2:0>, respectively.) The attenuation attack rate and depth can be configured through SMUTER<1:0> and SMUTEA<1:0>, respectively. The target volume can be configured through VOLUMET<4:0>. SNR value can also be used as the judgment threshold in FM mode by setting SMMD to 1.

3.8.3. Stereo / Mono Blending

In order to provide a comfortable listening experience, KT0915 blends the stereo signal with mono signal gradually when in weak reception in FM mode. The signal level range over which the blending occurs is set by BLNDADJ<1:0>. The blending is disabled when DBLND is set to 1.

MONO playback mode can be forced by setting the MONO to 1.

If the MONO bit and the INV_LEFT_AUDIO bit are both set to 1, then a fully differential signal will be output at the LOUT and ROUT.

3.8.4. Bass

KT0915 provides bass boost feature for audio enhancement. The gain of the bass boost can be programmed through BASS<1:0>. With BASS<1:0>=00, this feature is disabled.

3.8.5. Stereo DAC, Audio Filter and Driver

Two high-quality single-bit $\Delta\Sigma$ audio digital-to-analog converters (DAC) are integrated along with high-fidelity analog audio filters and class AB drivers. Headphones with impedance as low as 16ohms can be directly driven without external audio drivers. An integrated anti-pop circuit suppresses the click-and-pop sound during power up and power down. For different load capacitor, user can set different anti-pop configuration through POP<1:0>.

3.8.6. AM Bandwidth

KT0915 provide programmable AM channel bandwidth through AM_BW<1:0>.

3.8.7. TUNE

The fully integrated LO synthesizer supports wide band operation. Channel tuning is started when the register AMTUNE/FMTUNE is set to 1.

In FM mode, the channel frequency is set by FMCHAN<11:0> and is defined as

$$\text{Freq(MHz)} = 50 \text{ KHz} \times \text{FMCHAN}\langle 11:0 \rangle$$

In AM mode, the channel frequency is set by AMCHAN<10:0> and is defined as

$$\text{Freq(KHz)} = 1 \text{ KHz} \times \text{AMCHAN}\langle 14:0 \rangle$$

3.8.8. SEEK

KT0915 offers effective software based seek algorithm. Refer to application notes for more information.

3.9. I2C Control Interface

The serial interface (I2C mode) is used to read and write the device registers, the external controller can directly read and write a register without going through any other registers first. There is also an internal address counter that automatically moves the pointer forward after a read/write operation so that the external controller can continuously read/write desired number of chip registers starting from any of address. The MSB of a register data is transferred first.

I2C bus mode uses SCL and SDA to transfer data. The device always drives data to SDA at the falling edge of SCL and captures data from SDA at the rising edge of SCL. The device acknowledges the external controller by driving SDA low at the falling edge of SCL. Data transfer always begins with START condition and ends with STOP condition. The external controller can read/write one 16-bits data at the specified address or read/write desired number of registers data continuously from the specified address till when STOP condition is occurred.

For write operations, external controller shall send command & data in the following sequence: START condition -> 7 bit chip address and Write command ("0") -> 8 bit register address n -> write data n [15:8] -> write data n [7:0] -> write data n+1 [15:8] -> write data n+1 [7:0] -> -> STOP condition.

For read operations, external controller shall send command & data in the following sequence: START condition -> 7 bit chip address and Write command ("0") -> 8 bit register address n -> 7 bit chip address and Read command ("1"), then device will send read data n [15:8] -> read data n [7:0] -> read data n+1 [15:8] -> read data n+1 [7:0] -> till STOP condition.

**Table 6: I2C Interface Protocol
RANDOM REGISTER WRITE PROCEDURE**

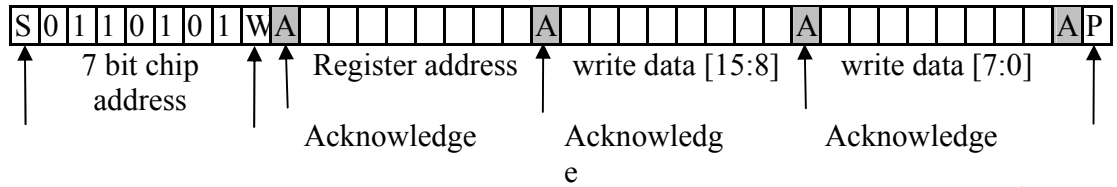

START condition

WRITE command

STOP condition

RANDOM REGISTER READ PROCEDURE

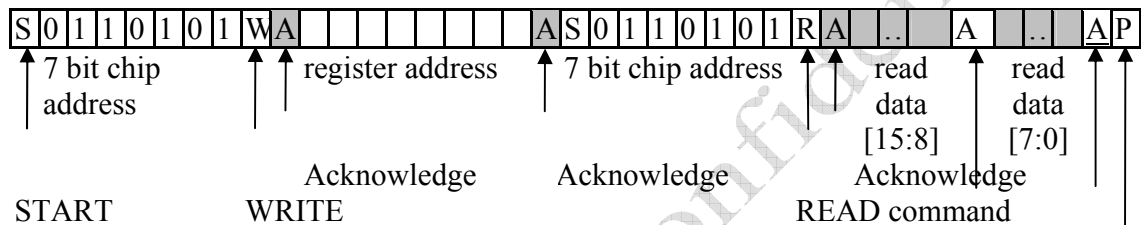

START condition

WRITE command

READ command

NO Acknowledge
STOP condition

Note: The data bits in gray color are sent by KT0915

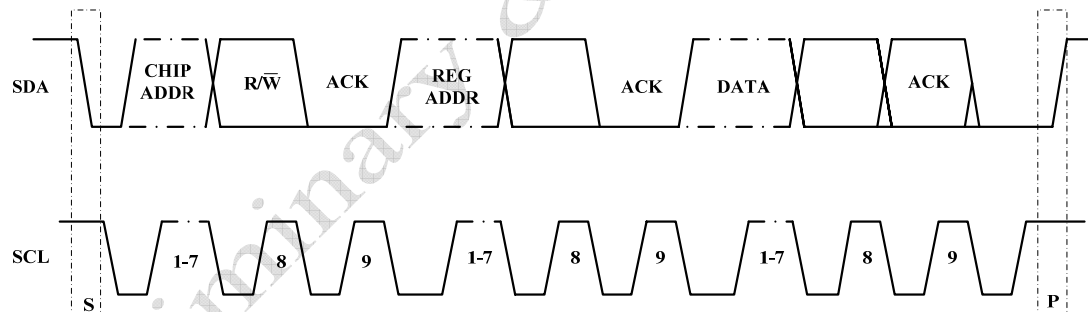

Figure 4: I2C interface timing diagram

3.10.Register Bank

Reg	Name	D15	D14	D13	D12	D11	D10	D9	D8	D7	D6	D5	D4	D3	D2	D1	D0
01h	CHIP ID																
02h	SREK														FMSPACE<10>	DMUTER	DMUTEL
03h	TUNE	FMTUNE									FMCHAN<140>						
04h	VOLUME	FMSMUTE	AMDSMUTE	DMUTE				BASS<10>				POP<10>					
05h	ISPCFBA	MONO			DE			BLNDADJ<10>				DBLND					
0Ah	LOCRGA								FMAATCD								
0Ch	LOCRGC													CAMPIUSB AND EN			
0Fh	RXCFG				STDBY										VOLUME<40>		
12h	STATUSA	XTAL_OK	STC			PLL_LOCK	LO_LOCK	ST<10>			FMRSSI<40>						
13h	STATUSB									RDCHAN<140>							
14h	STATUSC	PWRSTATE		CHRDY				FMSNR<60>									
16h	SYSCFG	AM/FM	USERBA ND		RCLK_EN		REFCLK<30>			AU_GAIN<10>							AMAFCD
17h	AMCHAN	AMTUNE								AMCHAN<100>							
18h	AMCALI									CAP_INDEX<130>							
1Dh	GPIO																
22h	AMDSP									AM_BW<10>					GPIO2<10>		GPIO1<10>
24h	AMSTATUSA																
25h	AMSTATUSB						AMRSSI<40>										
2Fh	SOFTMUTE	SMUTERA<10>		SMUTER<10>			AM_SMT<20>			VOLUMEI<40>				SMMD		FM_SMT<20>	
2Fh	USERS/TARICH									USER_START_CHAN<140>							
30h	USERSTARTNUM									USER_CHAN_NUM<110>							
31h	USERCHANNUM									KEY_MODE<10>							
33h	AMCFG	AMSPACE<10>															
34h	AMCFG2																
3Ch	ATC																FM_AFC_DELTA<70>

3.10.1. CHIP ID (Address 0x01)

Bit	Symbol	Access	Default	Functional Description
15:0	KT Mark	R	0x4B54	ASCII form of string "KT"

3.10.2. SEEK (Address 0x02)

Bit	Symbol	Access	Default	Functional Description
15:4	Reserved	RW	000 0000 0000	Reserved
3:2	FMSPACE<1:0>	RW	01	FM Channel Spacing 00 = 200KHz 01 = 100KHz 10 = 50KHz
1	DMUTER	RW	1	Right Channel Mute Control 0 = Right mute enable 1 = Right mute disable
0	DMUTEL	RW	1	Left Channel Mute Control 0 = Left channel mute enable 1 = Left channel mute disable

3.10.3. TUNE (Address 0x03)

Bit	Symbol	Access	Default	Functional Description
15	FMTUNE	RW	0	FM Tune Enable 0 = Normal operation 1 = Start to tune to desired FM channel
14:12	Reserved	RW	000	Reserved
11:0	FMCHAN<11:0>	RW	0110_1011_1000 (0x06B8)	FM Channel Setting FMCHAN<11:0>=Frequency (KHz) / 50KHz. For example, if desired channel is 86MHz, then the FMCHAN<11:0> should be 0x06B8.

3.10.4. VOLUME (Address 0x04)

Bit	Symbol	Access	Default	Functional Description
15	FMDSMUTE	RW	1	FM Softmute Disable 0 = FM softmute enable 1 = FM softmute disable

14	AMDSMUTE	RW	1	AM Softmute Disable 0 = AM softmute enable 1 = AM softmute disable
13	DMUTE	RW	0	Mute Disable 0 = Mute enable 1 = Mute disable
12:10	Reserved	RW	000	Reserved
9:8	BASS<1:0>	RW	00	Bass Boost Effect Mode Selection 00 = Disable 01 = Low 10 = Med 11 = High
7:6	Reserved	RW	10	Reserved
5:4	POP<1:0>	RW	00	Audio DAC Anti-pop Configuration 00 : 100uF AC-coupling capacitor 01 : 60uF AC-coupling capacitor 10 : 20uF AC-coupling capacitor 11 : 10uF AC-coupling capacitor
3:0	Reserved	RW	0000	Reserved

3.10.5. DSPCFGA (Address 0x05)

Bit	Symbol	Access	Default	Functional Description
15	MONO	RW	0	Mono Select 0 = Stereo 1 = Force mono To be noted that if both MONO bit and INV_AUDIO_LEFT are set to 1, fully differential audio signal can be obtained from LOUT and ROUT pin.
14:12	Reserved	RW	001	Reserved
11	DE	RW	0	De-emphasis Time Constant Selection 0 = 75us 1 = 50us
10	Reserved	RW	0	Reserved
9:8	BLNDADJ<1:0>	RW	00	Stereo/Mono Blend Level Adjustment 00 = High 01 = Highest 10 = Lowest 11 = Low Note: Write 00 explicitly even if 00 is the default value.
7:6	Reserved	RW	0	Reserved

5	DBLND	RW	0	Blend disable 0 = Blend enable 1 = Blend disable
4:0	Reserved	RW	0_0000	Reserved

3.10.6. LOCFGGA (Address 0x0A)

Bit	Symbol	Access	Default	Functional Description
15:9	Reserved	RW	0000_000	Reserved
8	FMAFCD	RW	1	AFC Disable Control Bit 0 = AFC enable 1 = AFC disable
7:0	Reserved	RW	0000_0000	Reserved

3.10.7. LOCFGC (Address 0x0C)

Bit	Symbol	Access	Default	Functional Description
15:4	Reserved	RW	0000_0000_0010	Reserved
3	CAMPUSBAND_EN	RW	0	Campus FM Band Enable 0 = User can only use 64MHz ~ 110MHz 1 = User can extend the FM band down to 32MHz
2:0	Reserved	RW	100	Reserved

3.10.8. RXCFG (Address 0x0F)

Bit	Symbol	Access	Default	Functional Description
15:13	Reserved	RW	100	Reserved
12	STDBY	RW	0	Standby Mode Enable 0 = Disable 1 = Enable
11:5	Reserved	RW	100_0000	Reserved
4:0	VOLUME<4:0>	RW	1_1111	Volume Control 11111 = 0dB 11110 = -2dB 11101 = -4dB 00010 = -58dB 00001 = -60dB 00000 = Mute

3.10.9. STATUSA (Address 0x12)

Bit	Symbol	Access	Default	Functional Description
15	XTAL_OK	R	NA	Crystal ready indicator 0 = Not ready 1 = Crystal is ok
14	STC	RW	0	Seek/Tune Complete 0 = Not Complete 1 = Complete Every time the Seek/tune process begins, the STC bit will clear to zero by hardware.
13:10	Reserved	R	NA	Reserved
11	PLL_LOCK	R	NA	System PLL Ready Indicator 0 = Not ready 1 = System PLL ready
10	LO_LOCK	R	NA	LO Synthesizer Ready Indicator 0 = Not ready 1 = Ready
9:8	ST<1:0>	R	NA	Stereo Indicator 11 = Stereo state Other = Mono state
7:3	FMRSSI<4:0>	R	NA	FM RSSI Value Indicator RSSI starts from -100dBm and step is 3dB, namely $RSSI(dBm) = -100 + FMRSSI<4:0> * 3dB$
2:0	Reserved	R	NA	Reserved

3.10.10. STATUSB (Address 0x13)

Bit	Symbol	Access	Default	Functional Description
15:12	Reserved	R	NA	Reserved
14:0	RDCHAN<14:0>	R	NA	Current Channel Indicator

3.10.11. STATUSC (Address 0x14)

Bit	Symbol	Access	Default	Functional Description
15	PWSTATUS	R	NA	Power Status Indicator 0 = Power not ready 1 = Power ready
14	Reserved	R	NA	Reserved
13	CHIPRDY	R	NA	Chip Ready Indicator 0 = Chip is not ready

				1 = Chip is ready, calibration done.
12:6	FMSNR<6:0>	R	NA	Channel SNR value is FM mode. 0000000 = Minimum SNR 1111111 = Maximum SNR
5:0	Reserved	R	NA	Reserved

3.10.12. AMSYSCFG (Address 0x16)

Bit	Symbol	Access	Default	Functional Description
15	AM_FM	RW	0	AM/FM Mode Control 0 = FM mode 1 = AM mode
14	USERBAND	RW	0	User Definition Band Enable 0 = Use internal defined band 1 = Use user-defined band which is specified in USER_START_CHAN<14:0>, USER_GUARD<8:0> and USER_CHAN_NUM<11:0>
13	Reserved	RW	0	Reserved
12	RCLK_EN	RW	0	Reference Clock Enable 0 = Crystal 1 = Reference clock
11:8	REFCLK<3:0>	RW	0000	Reference Clock Selection 0000 = 32.768KHz 0001 = 6.5MHz 0010 = 7.6MHz 0011 = 12MHz 0100 = 13MHz 0101 = 15.2MHz 0110 = 19.2MHz 0111 = 24MHz 1000 = 26MHz 1001 = 38KHz
7:6	AU_GAIN<1:0>	RW	00	Audio Gain Selection 01 = 6dB 00 = 3dB 11 = 0dB 10 = -3dB
5:1	Reserved	RW	0 0001	Reserved
0	AMAFCD	RW	0	AFC Disable Control in AM Mode 0 = Enable 1 = Disable

3.10.13. AMCHAN (Address 0x17)

Bit	Symbol	Access	Default	Functional Description
15	AMTUNE	RW	0	AM Tune Enable
14:0	AMCHAN<14:0>	RW	000_0001_1111_1000 (0x01F8)	AM Channel Setting AMCHAN<14:0> = Frequency(in KHz)

3.10.14. AMCALI (Address 0x18)

Bit	Symbol	Access	Default	Functional Description
15:14	Reserved	RW	00	Reserved
13:0	CAP_INDEX<13:0>	R	NA	On Chip Capacitor for AM Antenna Calibration 0x0000 = Minimum capacitor 0x3FFF = Maximum capacitor

3.10.15. GPIOCFG (Address 0x1D)

Bit	Symbol	Access	Default	Functional Description
15:4	Reserved	RW	0000 0000 0000	Reserved
3:2	GPIO2<1:0>	RW	00	VOL Pin Mode Selection 00 = High Z 01 = Key controlled volume increase/decrease 10 = Dial controlled volume increase/decrease 11 = Reserved
1:0	GPIO1<1:0>	RW	00	CH Pin Mode Selection 00 = High Z 01 = Key controlled channel increase / decrease 10 = Dial controlled channel increase / decrease 11 = Reserved

3.10.16. AMDSP (Address 0x22)

Bit	Symbol	Access	Default	Functional Description
15:8	Reserved	RW	1010 1111	Reserved
7:6	AM_BW<1:0>	RW	00	AM Channel Bandwidth Selection 00 = 2KHz

				01 = 2KHz 10 = 4KHz 11 = 6KHz
5:4	Reserved	RW	00	Reserved
3	INV_LEFT_AUDIO	RW	0	Left Channel Inverse Control 0 = Normal operation 1 = Inversing the left channel audio signal. A fully differential audio signal can be got from LOUT and ROUT if both of the INV_LEFT_AUDIO bit and MONO bit are set to 1.
2:0	Reserved	RW	100	Reserved

3.10.17. AMSTATUSA (Address 0x24)

Bit	Symbol	Access	Default	Functional Description
15:13	Reserved	RW	000	Reserved
12:8	AMRSSI<4:0>	R	NA	AM Channel RSSI AM RSSI starts from -90dBm and step is 3dB, namely $AMRSSI(dBm) = -90 + AMRSSI<4:0> * 3dB$
7:0	Reserved	R	NA	Reserved

3.10.18. AMSTATUSB (Address 0x25)

Bit	Symbol	Access	Default	Functional Description
15:8	Reserved	R	NA	Reserved
7:0	AM_AFCDELTA<7:0>	R	NA	Signed binary, max 16KHz , min -16KHz, step is 128Hz.

3.10.19. SOFTMUTE (Address 0x2Eh)

Bit	Symbol	Access	Default	Functional Description
15:14	SMUTEA<1:0>	RW	00	Softmute Attenuation 00 = Strong 01 = Strongest 10 = Weak 11 = Weakest
13:12	SMUTER<1:0>	RW	00	Softmute Attack/Recover Rate 00 = Slowest

				01 = Fastest (RSSI mode only) 10 = Fast 11 = Slow
11:9	AM_SMTH<2:0>	RW	000	AM Softmute Start Level. 000 = Lowest 001 = ... 111 = Highest
8:4	VOLUMET<4:0>	RW	0_0001	Softmute Target Volume 0000 : Minimum volume 1111 : Maximum volume
3	SMMD	RW	0	Softmute Mode Selection 0 = RSSI mode 1 = SNR mode (only effective in FM mode)
2:0	FM_SMTH<2:0>	RW	000	FM Softmute Start Threshold 000 = Lowest 001 = ... 111 = Highest

3.10.20. USERSTARTCH (Address 0x2F)

Bit	Symbol	Access	Default	Functional Description
15	Reserved	RW	0	Reserved
14:0	USER_START_CHAN<14:0>	RW	000_1000_1111_1100 (0x08FC(2.3MHz))	User band start channel, only effect when USERBAND=1. See section 3.7.3.

3.10.21. USERGUARD (Address 0x30)

Bit	Symbol	Access	Default	Functional Description
15:9	Reserved	RW	0000_000	Reserved
8:0	USER_GUARD<8:0>	RW	0_0111_1000	User band guard number, only effective when USERBAND=1. See section 3.7.2.

3.10.22. USERCHANNUM (Address 0x31)

Bit	Symbol	Access	Default	Functional Description
15:12	Reserved	RW	0000	Reserved
11:0	USER_CHAN_NUM<11:0>	RW	0001_1111_0100 (0x01F4(500))	User band channel number, only effective when USERBAND=1. See section 3.7.3.

3.10.23. AMCFG (Address 0x33)

Bit	Symbol	Access	Default	Functional Description
15:14	AMSPACE<1:0>	RW	00	AM Channel Space Selection 00 = 1KHz 01 = 9KHz 10 = 10KHz 11 = 10KHz
13:7	Reserved	RW	01 0100 0	Reserved
6:5	KEY_MODE<1:0>	RW	00	Working mode selection when key mode is selected. 00 = Working mode A 01 = Working mode B Others = Reserved For detailed information about working mode A and working mode B, please refer to section 3.7.1.
4:0	Reserved	RW	0 0001	Reserved

3.10.24. AMCFG2 (Address 0x34h)

Bit	Symbol	Access	Default	Functional Description
15:6	Reserved	RW	0100 0000 01	Reserved
5:4	TIME1<1:0>	RW	01	TIME1 00 = Shortest 11 = Longest
3:1	TIME2<2:0>	RW	000	TIME2 000 = Fastest 111 = Slowest
0	Reserved	RW	0	Reserved

3.10.25. AFC (Address 0x3Ch)

Bit	Symbol	Access	Default	Functional Description
15:8	Reserved	R	NA	Reserved
7:0	FM_AFC_DELTAF <7:0>	R	NA	Frequency difference between CHAN and received signal, calculated by AFC block in two's complement format. Range is -127 to +127. Unit is KHz. This register is valid when STC=1

4. Typical Application Circuit

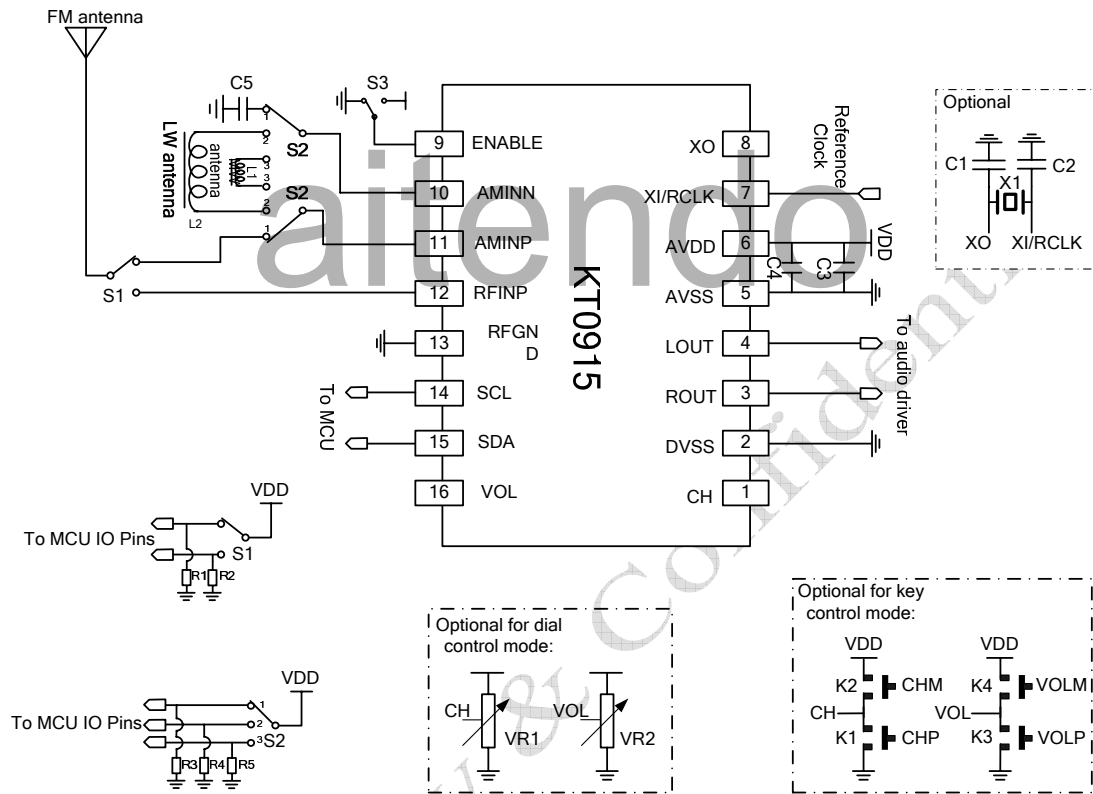
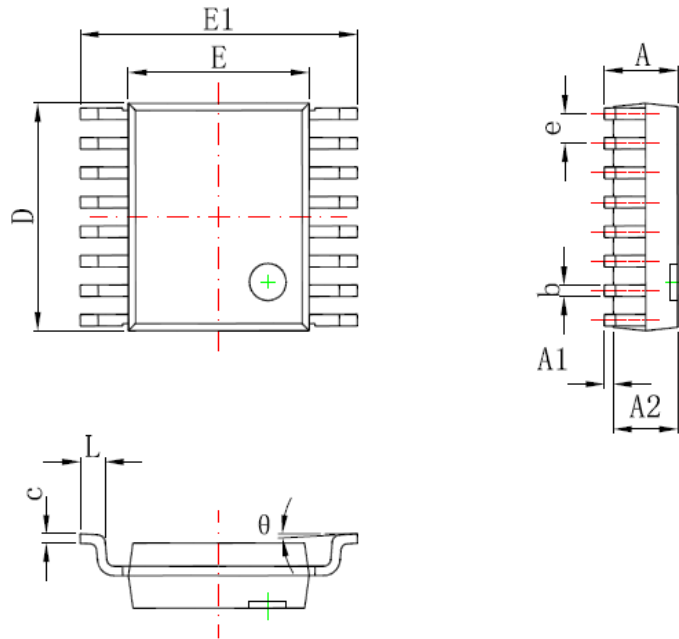

Figure 5: Typical application circuits

Components	Description	Value
C1, C2	Crystal load capacitor,	24pF
C3, C4	Supply decoupling capacitor	C3=10uF C4=0.1uF
C5	AC coupling capacitor	0.1uF
L1	MW ferrite antenna	350uH
L2	LW ferrite antenna	2800uH
X1	Crystal	32.768KHz
S1, S2, S3	Switch	
R1, R2, R3, R4, R5	IO pull down resistor	100kohm
VR1, VR2	Variable resistor	
K1~K4	Key-press	

5. Package Outline



Symbol	Dimensions In Millimeters		Dimensions In Inches	
	Min	Max	Min	Max
A	1.350	1.750	0.053	0.069
A1	0.100	0.250	0.004	0.010
A2	1.350	1.550	0.053	0.061
b	0.200	0.300	0.008	0.012
c	0.170	0.250	0.007	0.010
D	4.700	5.100	0.185	0.200
E	3.800	4.000	0.150	0.157
E1	5.800	6.200	0.228	0.244
e	0.635 (BSC)		0.025 (BSC)	
L	0.400	1.270	0.016	0.050
θ	0°	8°	0°	8°

6. Order Information

Part number	Description	Package
KT0915	Monolithic Digital FM/MW/SW/LW Receiver	SSOP16L, Pb free, 5000 pcs per box

7. Revision History

- V0.1 Initial Draft based on the top-level document V2.9.
- V0.11 Updated summary and company address.
- V0.12 Polishing and prove-reading.
- V0.20 Modified register map.
Added order information.
Modified Table 1, Table 3, Table 4 and Table 6.
- V0.21 Modified register map.
- V0.22 Modified Figure 1.

Preliminary & Confidential