

**Dimensions**

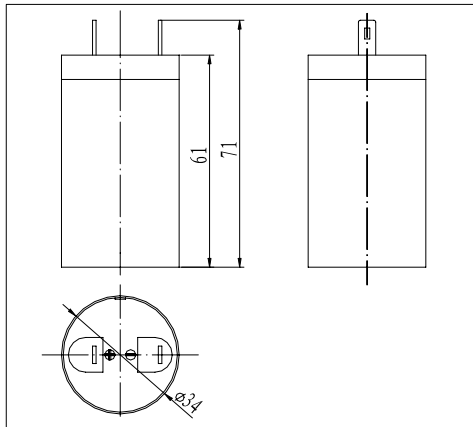

**The Relationship for Open Circuit Voltage and Residual Capacity (25°C)**

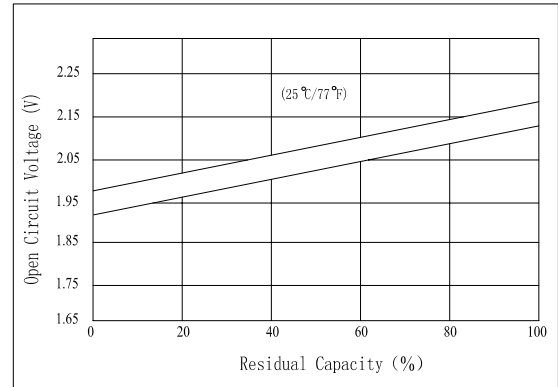

**Specifications**

Nominal Voltage	2 V	
Capacity(20HR, 25°C)	2.5Ah	
Dimension	Length	φ 34mm (1.34inch)
	Width	/
	Height	61mm (2.40inch)
	Total Height	71mm (2.80inch)
Approx. Weight	0.16kg (0.35lbs)	
Internal resistance (Fully charged, 25°C)	Approx.6m Ω	
Capacity affected by temperature (20HR)	40°C	102%
	25°C	100%
	0°C	85%
	-15°C	65%
Self-discharge (25°C)	3 month	Remaining Capacity: 91%
	6 month	Remaining Capacity: 82%
	12 month	Remaining Capacity: 65%
Nominal operating temperature	25°C ± 3°C (77°F ± 5°F)	
Operating temperature range	-15°C ~ 50°C (5°F ~ 122°F)	
Float charging voltage(25°C)	2.27 to 2.30V	
Cyclic charging voltage(25°C)	2.42 to 2.48V	
Maximum charging current	0.75A	
Terminal material	Copper	
Maximum discharge current	37.5A(5 sec.)	

**Charging Characteristics(25°C)**

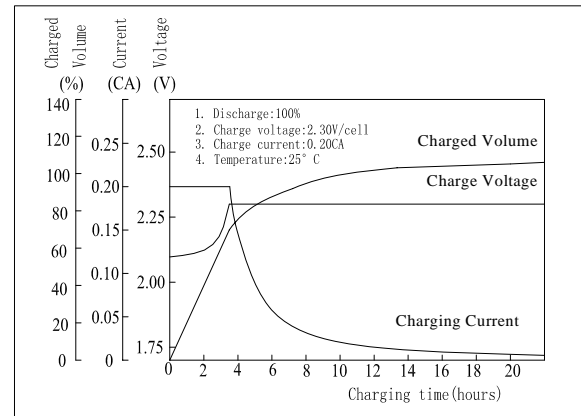

**Cycle Life(25°C)**

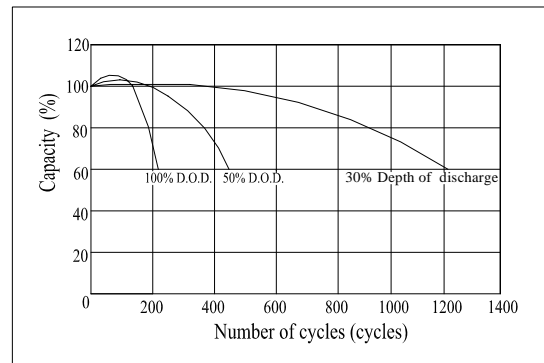

- ◆ Absorbent glass mat technology;
- ◆ Recognized by UL & CE;
- ◆ ABS container.

Note: Floating life at 20°C designed for 3 to 5 years.

**Constant Current Discharge Characteristics (A, 25°C)**

F.V/TIME	5min	10min	15min	30min	60min	3h	5h	10h	20h
1.60V	11.8	7.00	5.00	3.20	1.75	0.65	0.41	0.22	0.127
1.70V	11.2	6.65	4.80	3.07	1.68	0.64	0.40	0.22	0.126
1.80V	10.5	6.25	4.56	2.92	1.60	0.63	0.39	0.22	0.125

**Constant Power Discharge Characteristics (Watt, 25°C)**

F.V/TIME	5min	10min	15min	30min	60min	3h	5h	10h	20h
1.60V	21.9	13.2	9.50	6.11	3.38	1.29	0.81	0.45	0.25
1.70V	20.9	12.5	9.12	5.87	3.24	1.27	0.80	0.44	0.25
1.80V	19.6	11.8	8.66	5.57	3.08	1.24	0.78	0.44	0.25