

PNP Silicon Epitaxial Planar Transistor

KTA2014

FEATURES

- Power dissipation.($P_C=200\text{mW}$)
- Excellent h_{FE} Linearity.
- Complementary to KTC4075.
- Small package.

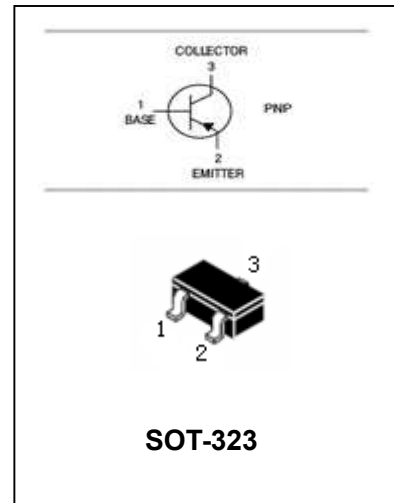

APPLICATIONS

- General purpose application and switching application.

ORDERING INFORMATION

Type No.	Marking	Package Code
KTA2014	SO/SY/SG	SOT-323

MAXIMUM RATING @ $T_a=25^\circ\text{C}$ unless otherwise specified

Symbol	Parameter	Value	Units
V_{CBO}	Collector-Base Voltage	-50	V
V_{CEO}	Collector-Emitter Voltage	-50	V
V_{EBO}	Emitter-Base Voltage	-5	V
I_C	Collector Current -Continuous	-150	mA
P_C	Collector Dissipation	100	mW
T_j, T_{stg}	Junction and Storage Temperature	-55 to +150	$^\circ\text{C}$

PNP Silicon Epitaxial Planar Transistor

KTA2014

ELECTRICAL CHARACTERISTICS @ Ta=25°C unless otherwise specified

Parameter	Symbol	Test conditions	MIN	TYP	MAX	UNIT
Collector-base breakdown voltage	$V_{(BR)CBO}$	$I_C = -0.1mA, I_E = 0$	-50			V
Collector-emitter breakdown voltage	$V_{(BR)CEO}$	$I_C = -1mA, I_B = 0$	-50			V
Emitter-base breakdown voltage	$V_{(BR)EBO}$	$I_E = -0.1mA, I_C = 0$	-5			V
Collector cut-off current	I_{CBO}	$V_{CB} = -50V, I_E = 0$			-0.1	μA
Emitter cut-off current	I_{EBO}	$V_{EB} = -5V, I_C = 0$			-0.1	μA
DC current gain	h_{FE}	$V_{CE} = -6V, I_C = -2mA$	70		400	
Collector-emitter saturation voltage	$V_{CE(sat)}$	$I_C = -100mA, I_B = -10mA$		-0.1	-0.3	V
Transition frequency	f_T	$V_{CE} = -10V, I_C = -1mA$	80			MHz
Collector output capacitance	C_{ob}	$V_{CB} = -10V, I_E = 0, f = 1MHz$		4	7	pF
Noise figure	NF	$V_{CE} = 6V, I_C = 0.1mA, f = 1KHz, R_g = 10K\Omega$		1.0	10	dB

CLASSIFICATION OF h_{FE}

Rank	O	Y	G
Range	70-140	120-240	200-240
marking	SO	SY	SG

TYPICAL CHARACTERISTICS @ Ta=25°C unless otherwise specified

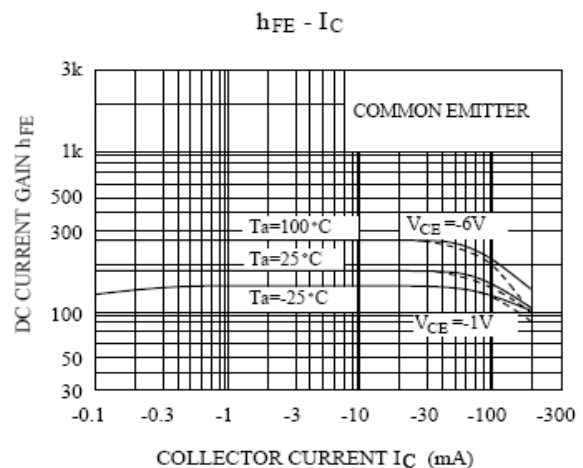
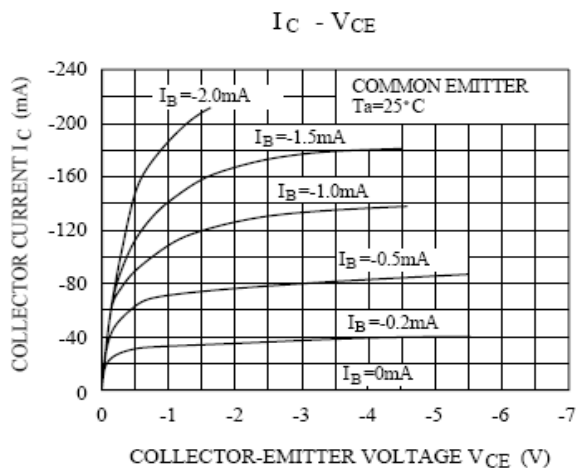

PNP Silicon Epitaxial Planar Transistor

KTA2014

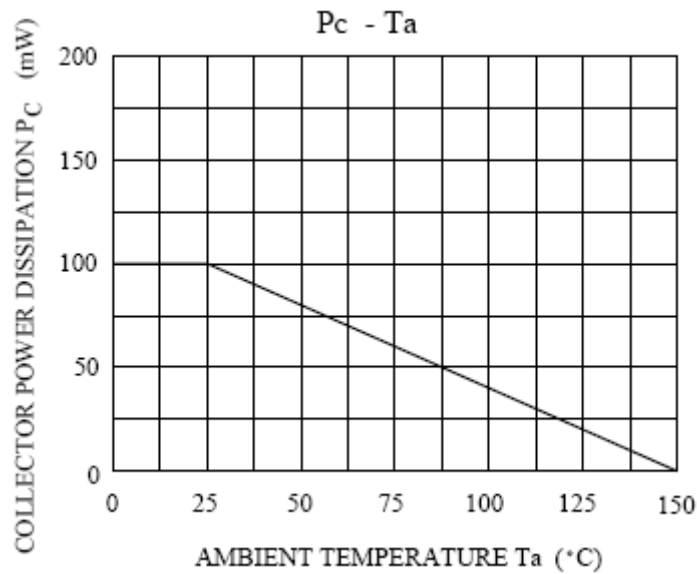
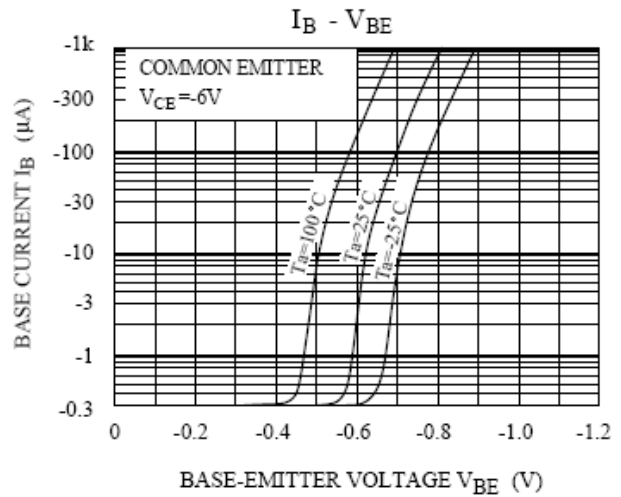
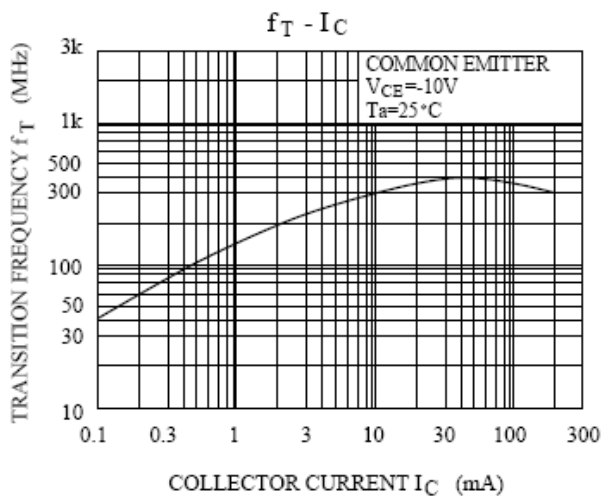
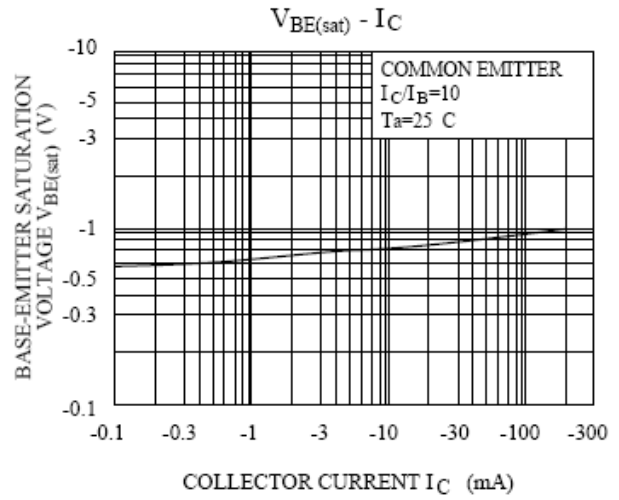
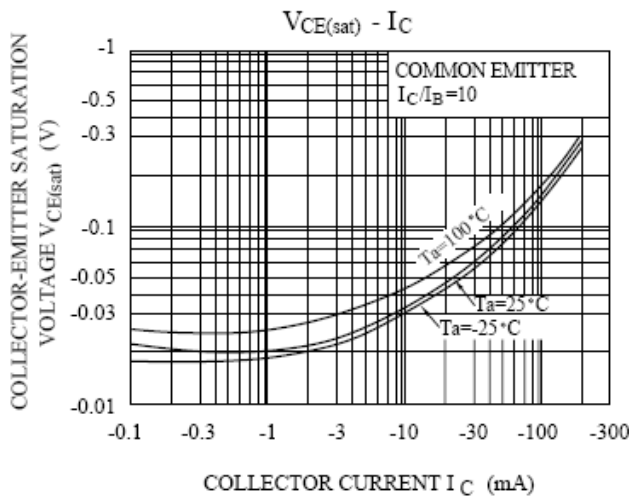

PNP Silicon Epitaxial Planar Transistor

KTA2014

PACKAGE OUTLINE

Plastic surface mounted package

SOT-323

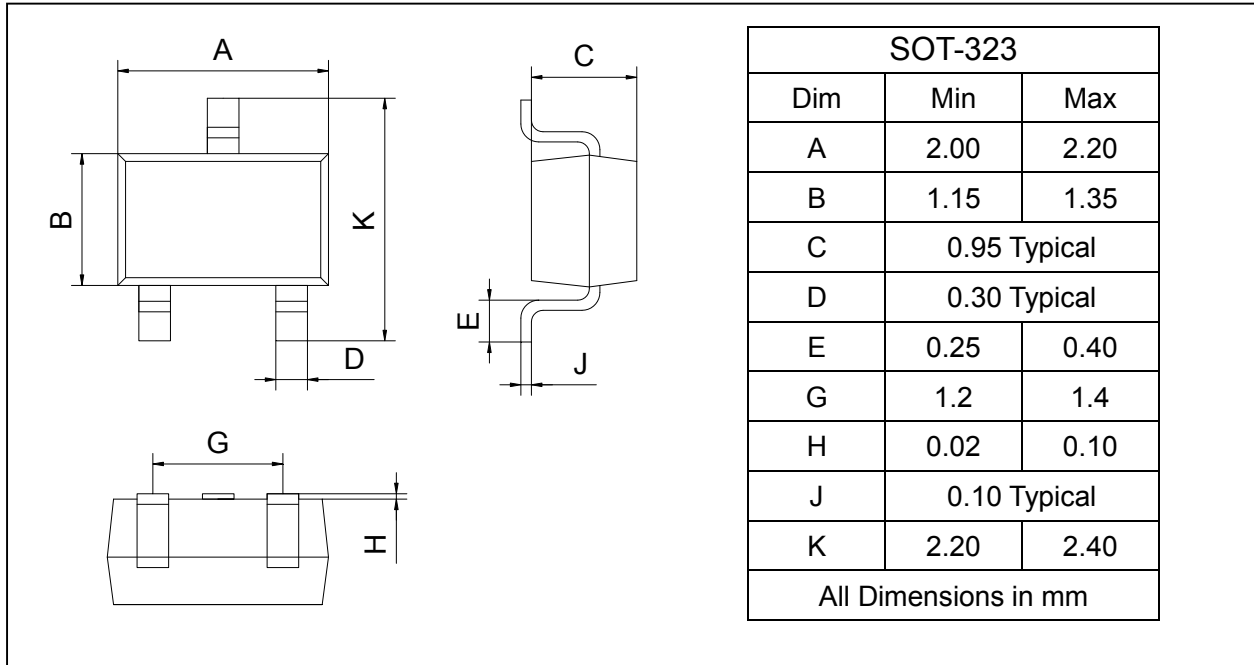

SOLDERING FOOTPRINT

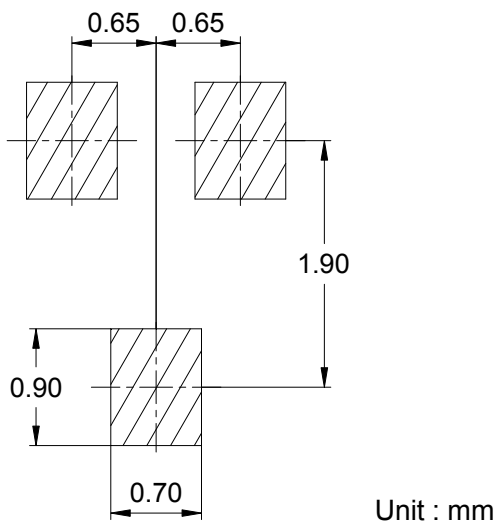

PACKAGE INFORMATION

Device	Package	Shipping
KTA2014	SOT-323	3000/Tape&Reel