

PNP Silicon Epitaxial Planar Transistor

KTA2015

FEATURES

- Power dissipation.($P_C=100\text{mW}$)
- Excellent h_{FE} Linearity.
- Complementary to KTC4076.
- Small package.

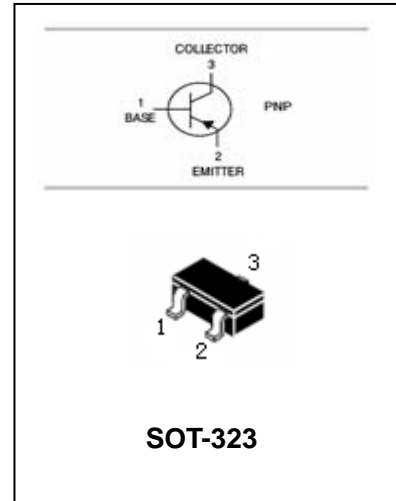

APPLICATIONS

- General purpose application and switching application.

ORDERING INFORMATION

Type No.	Marking	Package Code
KTA2015	ZO/ZY	SOT-323

MAXIMUM RATING @ $T_a=25^\circ\text{C}$ unless otherwise specified

Symbol	Parameter	Value	Units
V_{CBO}	Collector-Base Voltage	-35	V
V_{CEO}	Collector-Emitter Voltage	-30	V
V_{EBO}	Emitter-Base Voltage	-5	V
I_C	Collector Current -Continuous	-500	mA
P_C	Collector Dissipation	100	mW
T_j, T_{stg}	Junction and Storage Temperature	-55 to +150	$^\circ\text{C}$

PNP Silicon Epitaxial Planar Transistor

KTA2015

ELECTRICAL CHARACTERISTICS @ Ta=25°C unless otherwise specified

Parameter	Symbol	Test conditions	MIN	TYP	MAX	UNIT
Collector-base breakdown voltage	$V_{(BR)CBO}$	$I_C = -50\mu A, I_E = 0$	-35			V
Collector-emitter breakdown voltage	$V_{(BR)CEO}$	$I_C = -1mA, I_B = 0$	-30			V
Emitter-base breakdown voltage	$V_{(BR)EBO}$	$I_E = -50\mu A, I_C = 0$	-5			V
Collector cut-off current	I_{CBO}	$V_{CB} = -35V, I_E = 0$			-0.1	μA
Emitter cut-off current	I_{EBO}	$V_{EB} = -5V, I_C = 0$			-0.1	μA
DC current gain	h_{FE}	$V_{CE} = -1V, I_C = -100mA$ $V_{CE} = -6V, I_C = -400mA$	70 25		240	
Collector-emitter saturation voltage	$V_{CE(sat)}$	$I_C = -100mA, I_B = -10mA$		-0.1	-0.25	V
Transition frequency	f_T	$V_{CE} = -6V, I_C = -20mA$		200		MHz
Collector output capacitance	C_{ob}	$V_{CB} = -6V, I_E = 0, f = 1MHz$		13		pF

CLASSIFICATION OF h_{FE}

Rank	O	Y
Range	70-140	120-240
marking	ZO	ZY

TYPICAL CHARACTERISTICS @ Ta=25°C unless otherwise specified

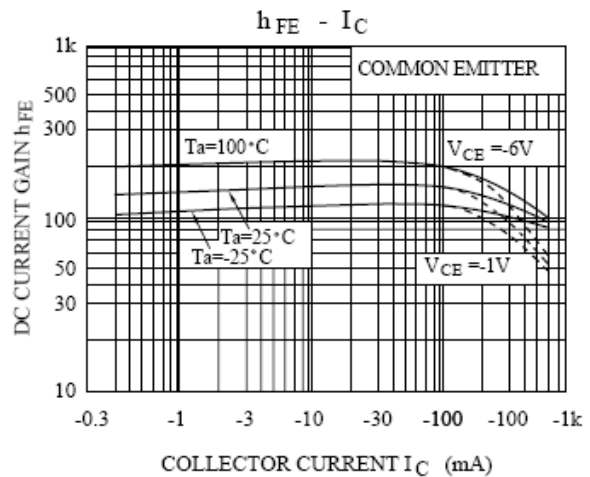
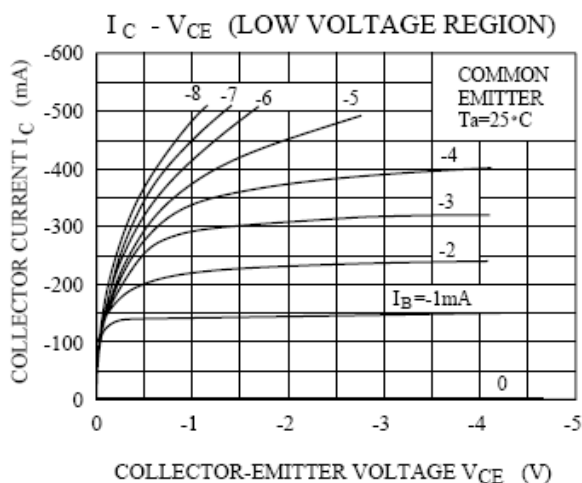

PNP Silicon Epitaxial Planar Transistor

KTA2015

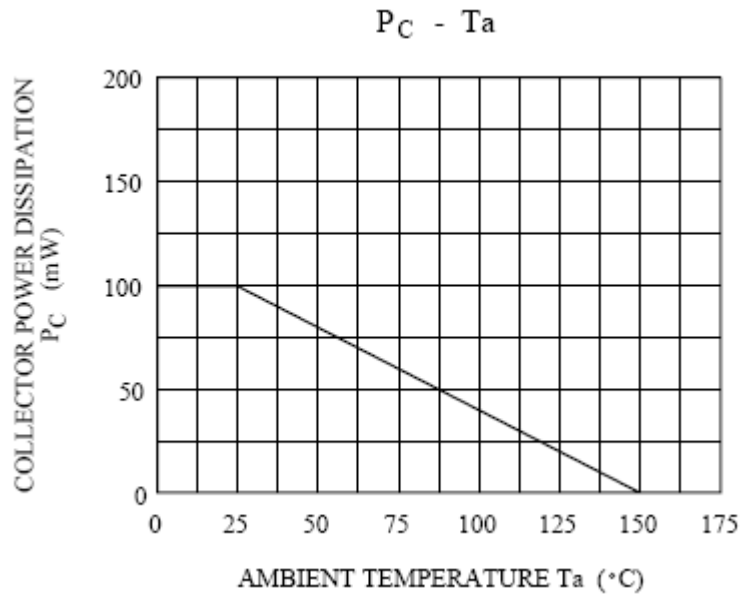
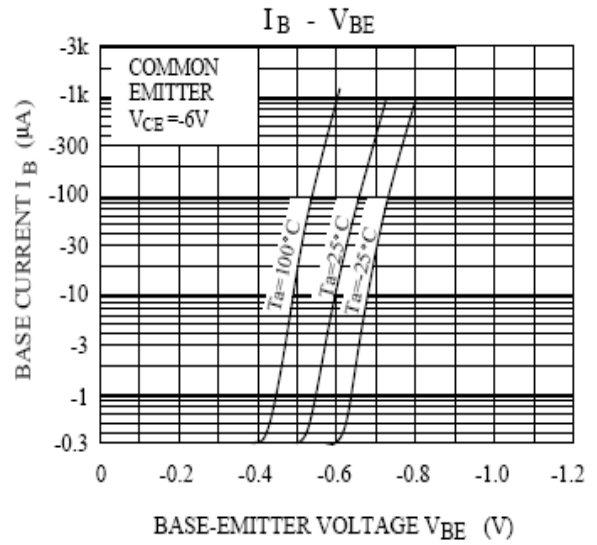
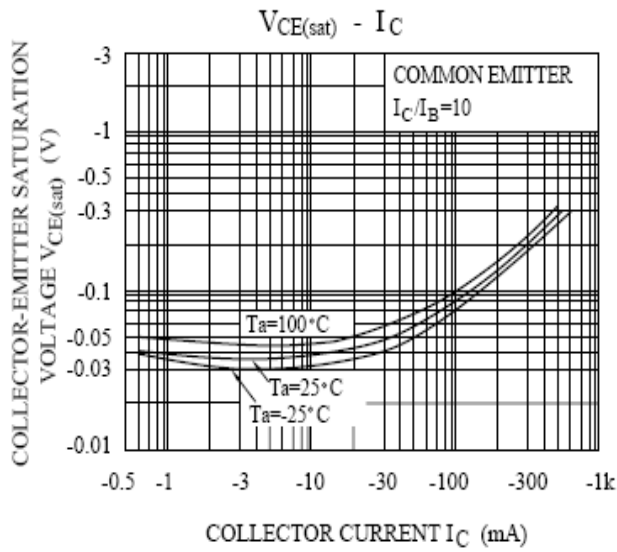

PNP Silicon Epitaxial Planar Transistor

KTA2015

PACKAGE OUTLINE

Plastic surface mounted package

SOT-323

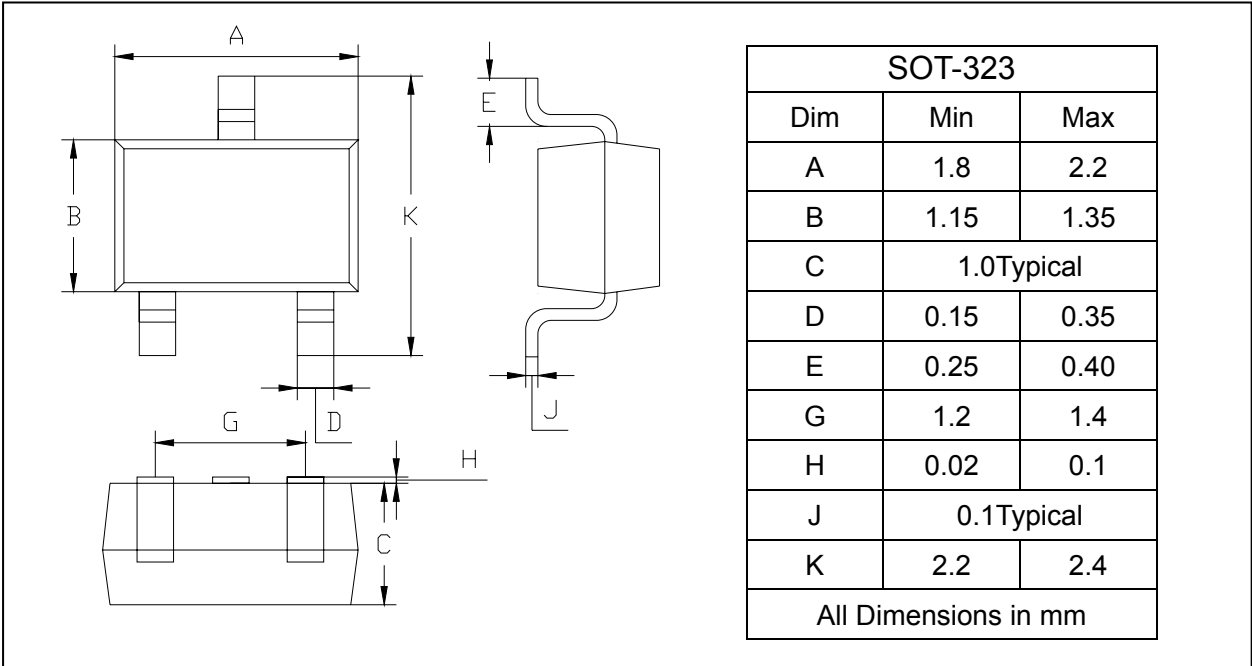

SOLDERING FOOTPRINT

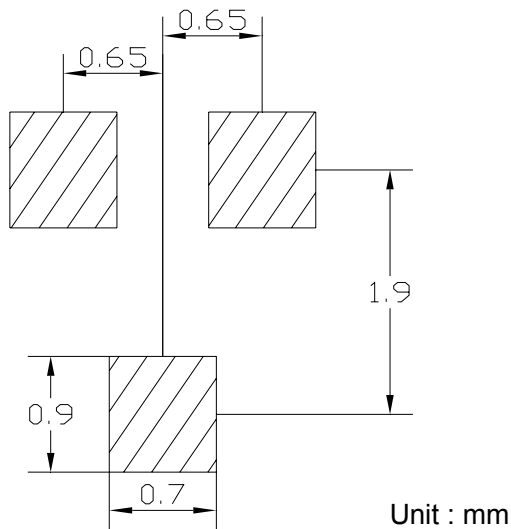

PACKAGE INFORMATION

Device	Package	Shipping
KTA2015	SOT-323	3000/Tape&Reel