

www.GESecurity.com

KTC-105

Black-and-White Legacy Camera

Overview

The KTC-105 is an economical, general purpose black-and-white security camera that offers 380 TV lines of resolution and high sensitivity (0.01 lux). The KTC-105 accepts both C- and CS-mount lenses. Its selectable backlight compensation prevents important foreground objects from becoming silhouetted against bright backgrounds.

Outstanding Features

The camera includes a variable high-speed electronic shutter that compensates for conditions ranging from bright sunlight to low-light environments.

For the best results in situations with wide variations in lighting, such as outdoor applications or indoor applications that call on the camera to perform daytime and after-hours surveillance, an autoiris lens is recommended. The KTC-105's autoiris circuit lets you use both video and DC autoiris lenses.



Standard Features

- **380 TV lines of resolution**
- **High sensitivity (0.01 lux)**
- **Variable high-speed electronic shutter**
- **Accepts video and DC autoiris lenses**
- **Lightweight miniature design**



KTC-105

Black-and-White Legacy Camera

Specifications

Image sensor

- 1/3 in interline transfer CCD

Signal system

- EIA standard, CCIR optional

Picture elements

- 542 H x 494 V (EIA), 542 H x 584 V (CCIR), 2:1 interlace

Scanning system

- 525/60 lines (EIA); 625/50 lines (CCIR)

Synchronizing system

- Internal

Resolution

- 380 TVL

Sensitivity

- 0.01 lux (faceplate), 0.1 lux @ f1.2 (scene)

Signal-to-noise ratio

- > 46 dB

Electronic shutter

- 1/60 to 1/80,000 sec, automatic adjustment

Video output

- 1.0 V pk-pk video at 75 ohm load

Lens mount

- C and CS mount

Autoiris lens

- Accepts video and DC autoiris lenses

Operating temperature

- 14° to 122° F (-10° to 50° C)

Power source

- 12 VDC

Power consumption

- 1.9 W

Grayscale

- Minimum 10 shades

Geometric distortion

- None

Control (switch)

- ELC: on (EE)/off (AI), Iris Control: ALC (DC/video), BLC: on/off

Humidity

- 0 to 95 percent, relative

Weight

- 7.3 oz (207 g)

Related Diagram

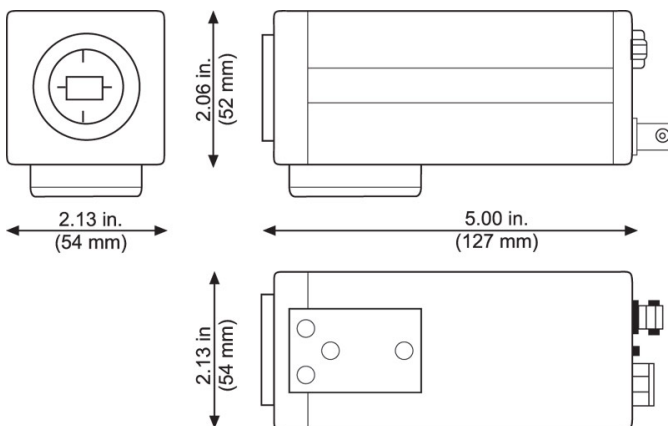

Ordering Information

KTC-105



GE Security

Mailing Address
4575 Research Way, STE 250
Corvallis, OR 97333 USA
www.GESecurity.com

Americas
800-469-1676 (US only)
tel 541-754-9133
fax 541-754-7162

Asia
tel 852-2907-8108
fax 852-2142-5063
Australia
tel 61-3-9259-4700
fax 61-3-9259-4799

Europe
tel 32-2-725-11-20
fax 32-2-721-86-13
Latin America
tel 305-267-4301
fax 305-267-4300

www.GESecurity.com