

The Kalatel KTC-105 is a B/W video camera that employs a 1/3-in. interline transfer charge-coupled device (CCD). It has a solid-state imaging device with a maximum of 270,000 (EIA) picture elements. The KTC-105 is lightweight, compact, and easy to install.

**CAUTION!**

Do not supply power to the unit before all installation steps have been completed.

INSTALLATION

To install the KTC-105, refer to Figure 1 and perform the following:

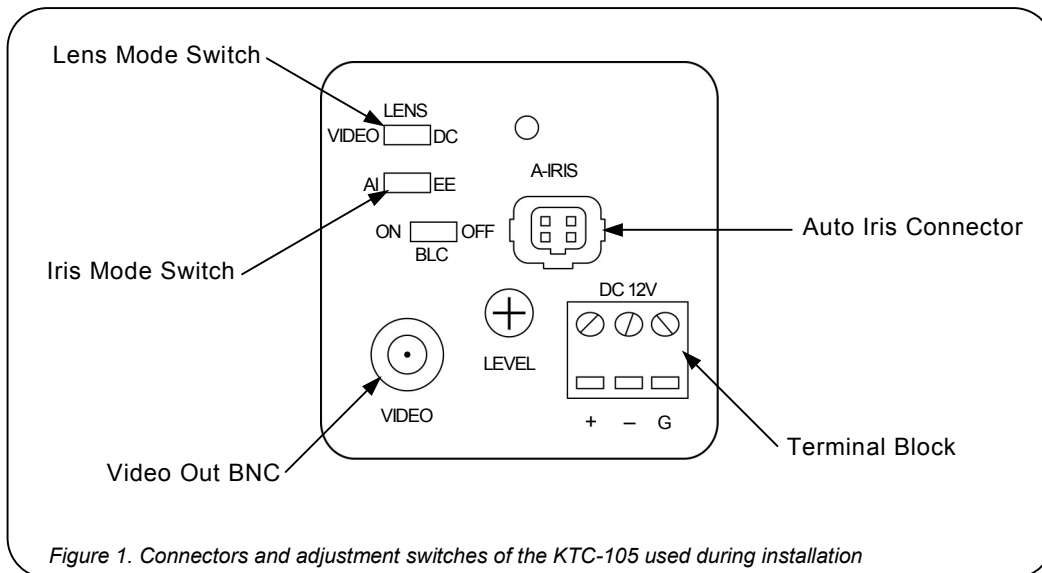

- 1) If you are using a C-mount lens, screw the provided C-mount adapter to the camera.
- 2) Screw the lens to the camera.
- 3) Set the iris mode switch to correspond with the iris:
 - If you are using a manual or fixed iris lens, set the iris mode switch to EE, which will engage the electronic iris.
 - If you are using an automatic iris lens, set the iris mode switch to AI.
 - a) Set the lens mode switch to correspond with the lens:
 - For an auto iris lens with built-in EE amp, set the lens mode switch to VIDEO.
 - For an auto iris lens without EE amp, set the lens mode switch to DC.
 - b) Insert the iris lens plug into the auto iris lens connector:
 - For auto iris lens with built-in EE amp, follow the connections in Figure 2. (Refer to the lens instructions.)
 - For auto iris lens without EE amp, follow the connections in Figure 3. (Refer to the lens instructions.)

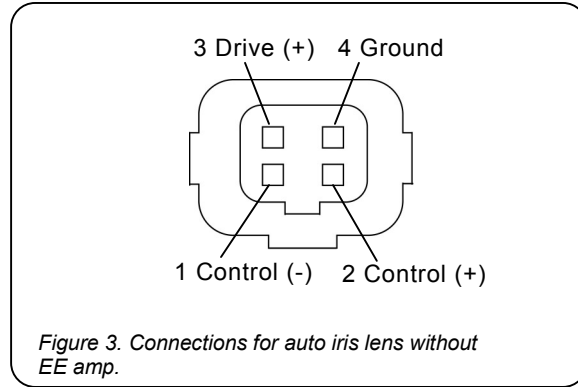
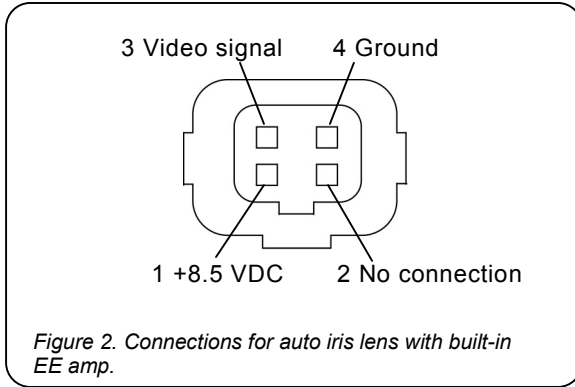

- 4) Attach the coaxial cable from the VIDEO OUT connector of the camera to the video in connector of the monitor.
NOTE: Ensure that the monitor is terminated in 75 ohm.
- 5) With a screwdriver, loosen the positive (+) and negative (-) terminal connectors on the terminal block.
- 6) Connect one lead of your power source to the positive terminal connector and the other to the negative terminal connector.
NOTE: The terminal block is reverse polarity protected; therefore, for the camera to work, the power leads must be connected to the correct terminals.
- 7) Retighten the terminal connector screws until snug, ensuring that the power leads are secure.
- 8) Turn the power source on.
NOTE: Power is now being supplied to the camera, and the PWR LED should be illuminated. If the PWR LED is not illuminated, check the terminal block connections and power source.

SETUP

Figure 4 shows the parts of the camera.

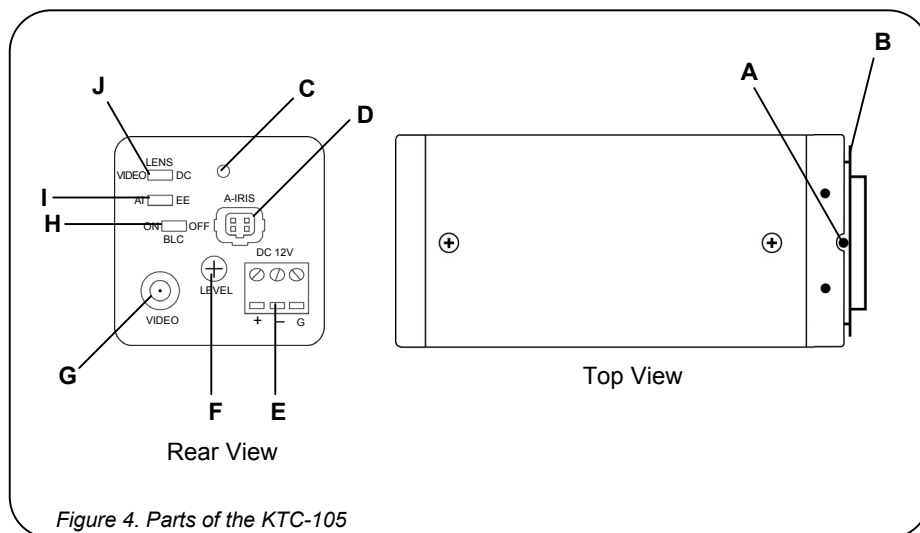

A Back focus adjustment lock screw**B** Back focus adjustment ring

Back focusing is used to match the lens' back focal length with the camera's imaging device. It enables the camera to be focused correctly during setup and ensures that the image remains sharp and crisp under various lighting conditions, taking into account changes in the lens' depth of field. To achieve correct back focus, adjustments should be made in low light—at night or in simulated low-light conditions and with the iris fully open (lowest f-number). Back focusing should always be done when the depth of field is at its minimum. The lens' depth of field will be reduced when the iris is fully open. (Depth of field: The proportion of the field of view that is in correct focus. Depth of field will decrease when the focal length is long, the f-number is small (iris fully open), or the object distance is short.)

To adjust the back focus, perform the following:

NOTE: This adjustment should be carried out only if the lens cannot be focused through the entire picture using the lens focus ring.

- 1) Operate the camera and view an object approximately 75 ft away.
- 2) If the lens has a focus ring, set it to infinity by turning it fully clockwise as viewed from the front of the camera.
- 3) If the lens has a manual iris, set the lens iris adjustment to the widest opening or lowest f-number. If the lens has an auto iris, place the appropriate neutral-density filter in front of the lens to simulate low-light conditions, which forces the iris to open fully.
- 4) Unscrew the back focus adjustment lock screw so that the back focus adjustment ring turns.
- 5) Adjust the lens' focal position (with the filter in place, if used) by gently turning the back focus adjustment ring to achieve the sharpest image.
- 6) Retighten the back focus adjustment lock screw carefully while ensuring that the focus does not change.
- 7) Position the camera for the required view and, if needed, adjust the focus using only the focus ring on the lens.
- 8) If you are using an auto iris lens, adjust the DC level for optimum performance.

C PWR LED**D** Auto iris lens connector**E** Terminal block**F** Level

When using a DC auto iris lens, the switch should be set to DC and the lens level adjusted to provide 1-V pk-pk composite video under full lighting conditions.

G VIDEO OUT (BNC)**H** Backlight Compensation

NOTE: The backlight function is available only if the camera is used with a manual lens.

Backlight compensation enables the camera to electronically compensate for bright background lighting and to show details that would otherwise be silhouetted.

NOTE: Compensation may be insufficient when the background is extremely bright.

I Iris mode switch**J** Lens mode switch

SPECIFICATIONS

Image device:	1/3-in. interline transfer CCD
Signal system:	EIA standard / CCIR optional
Picture Elements:	EIA: 542(H) x 494(V), CCIR: 542(H) x 584(V)
Scanning system:	EIA: 525 lines, CCIR: 625 lines; 2:1 interlace
Sync system	
12 VDC:	Internal
Horizontal resolution:	380 TV lines
Sensitivity:	0.1 lux at F1.2
Aperture correction:	H aperture and V aperture
Gain:	31 dB
Signal-to-noise ratio:	Better than 46 dB
Electronic shutter speed:	1/60 sec – 1/80,000 sec
Auto iris mode shutter speed:	1/60 (1/60) sec
Auto iris lens:	Accepts Video or DC type lenses
ATW:	2500° K – 9500° K
AWB:	Conventional white balance
Gamma:	.45/1
Video output signal:	Composite: 1 V pk-pk (EIA/CCIR)
Y/C output:	Y: 1.0 V pk-pk; C: 0.3 V pk-pk at 75-ohm load
Lens mount:	CS-mount with 5-mm C-mount adapter
Operating temperature:	14° F – 122° F (-10° C – 50° C)
Power source:	12 VDC (non-polarity)
Power consumption:	1.5 w
Dimensions (W x H x D):	55 x 65 x 125 mm
Weight:	7.3 oz (207 g)

Warranty and Return Information**Three-Year Warranty***

Kalatel warrants its products for a period of three years from the date of factory shipment. The warranty specifically covers any defects in material and workmanship, and does not cover equipment that has been abused, damaged, or modified.

Contact the factory for repairs, credit returns, advance replacements, and loaners.

*MobileView® and the monitor CRT carry a 12-month warranty.

Technical Support

Kalatel offers 24-hr technical support 7 days a week.

Call: 800-469-1676 (6 a.m. – 5 p.m. PST Mon. – Fri.)
541-740-3589 (all other times; limited support)

Fax: 541-752-9096 (available 24 hr a day)

An RMA number will be issued for returns. Call 800-469-1676
Monday through Friday between 6 a.m. and 5 p.m. PST.

KALATEL
—interlogi company