



TO-92L Plastic-Encapsulate Transistors

KTC3227 TRANSISTOR (NPN)

FEATURES

- Complementary to KTA1274

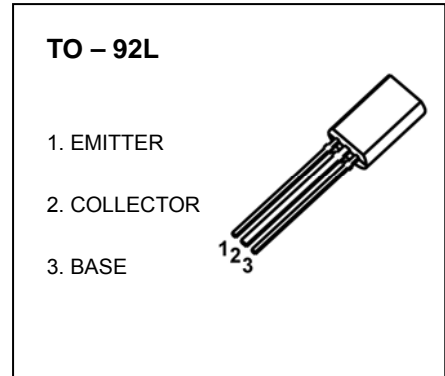

MAXIMUM RATINGS (T_a=25°C unless otherwise noted)

Symbol	Parameter	Value	Unit
V _{CB0}	Collector-Base Voltage	80	V
V _{CEO}	Collector-Emitter Voltage	80	V
V _{EBO}	Emitter-Base Voltage	5	V
I _C	Collector Current	0.4	A
P _C	Collector Power Dissipation	1	W
R _{θJA}	Thermal Resistance From Junction To Ambient	125	°C/W
T _j	Junction Temperature	150	°C
T _{stg}	Storage Temperature	-55~+150	°C

ELECTRICAL CHARACTERISTICS (T_a=25°C unless otherwise specified)

Parameter	Symbol	Test conditions	Min	Typ	Max	Unit
Collector-base breakdown voltage	V _{(BR)CBO}	I _C = 1mA, I _E =0	80			V
Collector-emitter breakdown voltage	V _{(BR)CEO}	I _C =5mA, I _B =0	80			V
Emitter-base breakdown voltage	V _{(BR)EBO}	I _E =1mA, I _C =0	5			V
Collector cut-off current	I _{CBO}	V _{CB} =50V, I _E =0			0.1	μA
Emitter cut-off current	I _{EBO}	V _{EB} =5V, I _C =0			0.1	μA
DC current gain	h _{FE(1)}	V _{CE} =2V, I _C =50mA	70		240	
	h _{FE(2)}	V _{CE} =2V, I _C =200mA	40			
Collector-emitter saturation voltage	V _{CE(sat)}	I _C =200mA, I _B =20mA			0.4	V
Base-emitter voltage	V _{BE}	V _{CE} =2V, I _C =5mA	0.55		0.8	V
Collector output capacitance	C _{ob}	V _{CB} =10V, I _E =0, f=1MHz		10		pF
Transition frequency	f _T	V _{CE} =10V, I _C =10mA		100		MHz

CLASSIFICATION OF h_{FE(1)}

RANK	O	Y
RANGE	70-140	120-240

Typical Characteristics

KTC3227

