

VHF/UHF WIDE BAND AMPLIFIER APPLICATION.

FEATURES

- Low Noise Figure, High Gain.
- NF=1.1dB, $|S_{21e}|^2=13\text{dB}$ (f=1GHz).

MAXIMUM RATING (Ta=25 °C)

CHARACTERISTIC	SYMBOL	RATING	UNIT
Collector-Base Voltage	V_{CBO}	20	V
Collector-Emitter Voltage	V_{CEO}	10	V
Emitter-Base Voltage	V_{EBO}	1.5	V
Collector Current	I_C	40	mA
Collector Power Dissipation	P_C	150	mW
Junction Temperature	T_j	150	°C
Storage Temperature Range	T_{stg}	-55~150	°C

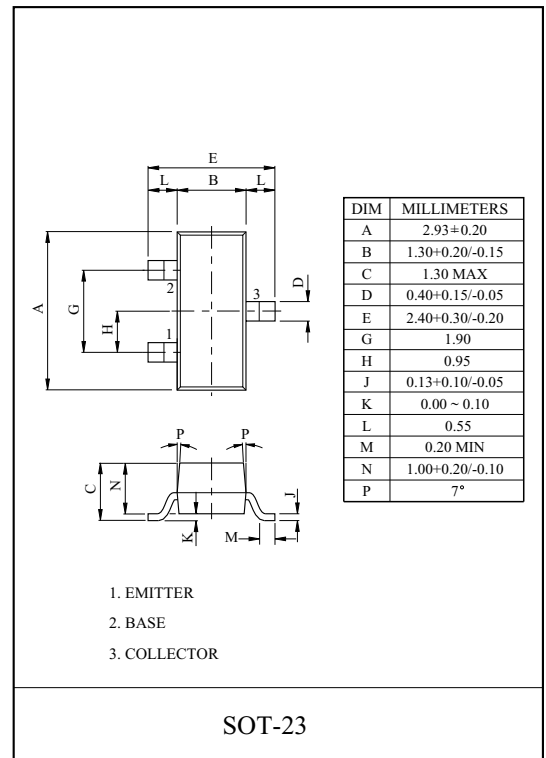

Marking

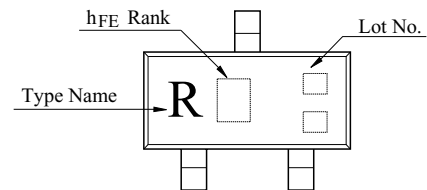

ELECTRICAL CHARACTERISTICS (Ta=25 °C)

CHARACTERISTIC	SYMBOL	TEST CONDITION	MIN.	TYP.	MAX.	UNIT
Collector Cut-off Current	I_{CBO}	$V_{CB}=10\text{V}, I_E=0$	-	-	1	μA
Emitter Cut-off Current	I_{EBO}	$V_{EB}=1\text{V}, I_C=0$	-	-	1	μA
DC Current Gain	h_{FE} (Note1)	$V_{CE}=8\text{V}, I_C=20\text{mA}$	50	-	250	
Collector Output Capacitance	C_{ob}	$V_{CB}=10\text{V}, I_E=0, f=1\text{MHz}$ (Note2)	-	0.7	-	pF
Reverse Transfer Capacitance	C_{re}		-	0.5	0.95	pF
Transition Frequency	f_T	$V_{CE}=8\text{V}, I_C=20\text{mA}$	7	10	-	GHz
Insertion Gain	$ S_{21e} ^2$ (1)	$V_{CE}=8\text{V}, I_C=20\text{mA}, f=1\text{GHz}$	10	13	-	dB
	$ S_{21e} ^2$ (2)	$V_{CE}=8\text{V}, I_C=20\text{mA}, f=2\text{GHz}$	-	7	-	dB
Noise Figure	NF (1)	$V_{CE}=8\text{V}, I_C=5\text{mA}, f=1\text{GHz}$	-	1.1	2.5	dB
	NF (2)	$V_{CE}=8\text{V}, I_C=5\text{mA}, f=2\text{GHz}$	-	1.7	-	dB

Note 1 : h_{FE} Classification H:50~100, J:80~160, K:125~250

Note 2 : C_{re} is measured by 3 terminal method with capacitance bridge.

KTC3600S

TYPICAL CHARACTERISTICS (Ta=25°C)

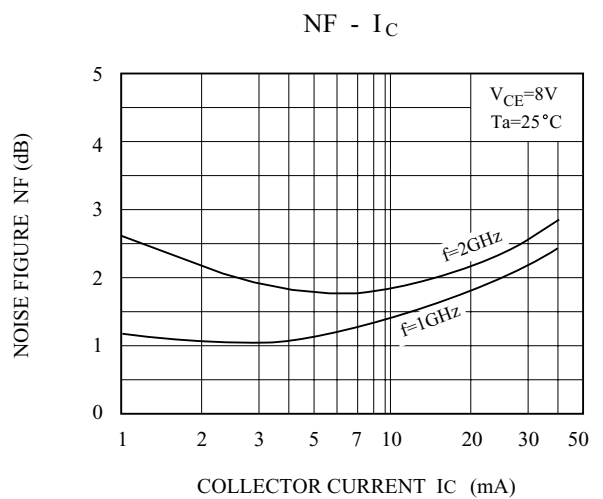
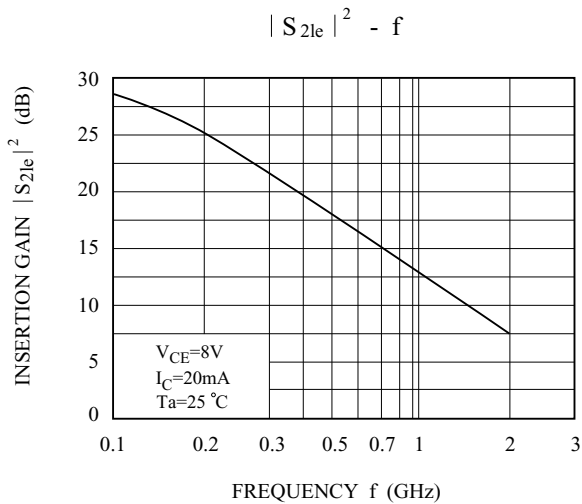
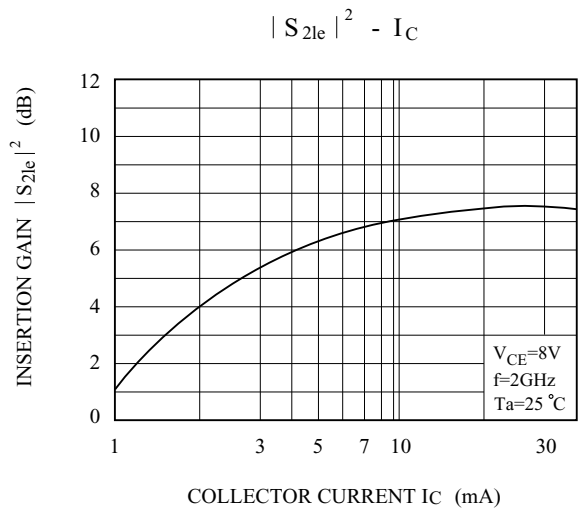
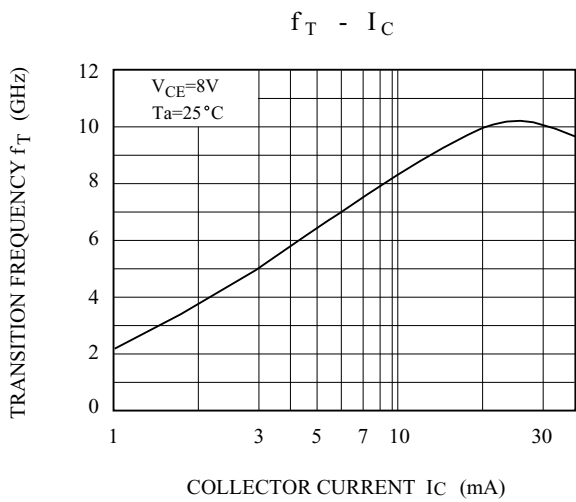
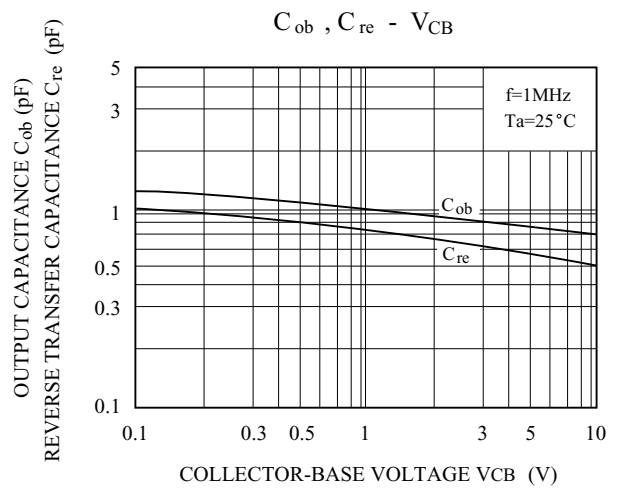
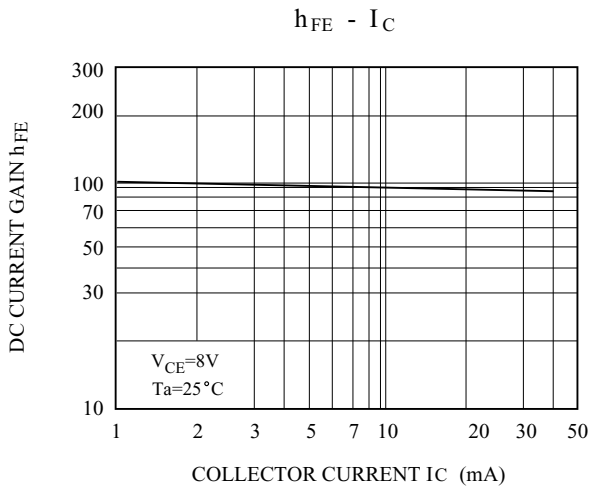

KTC3600S

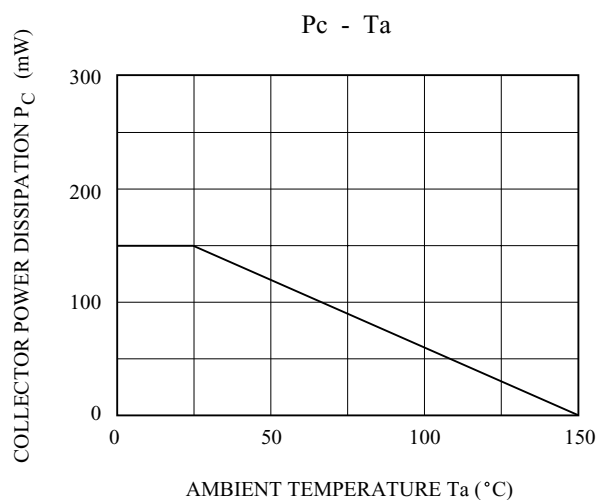
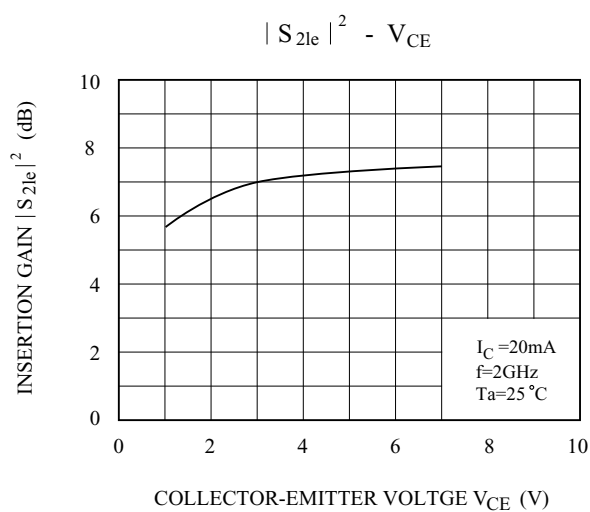

S-PARAMETER

($V_{CE}=8V$, $I_C=5mA$, $Z_O=50\ \Omega$, $T_a=25\ ^\circ C$)

Frequency (MHz)	$ S_{11} $		$ S_{21} $		$ S_{12} $		$ S_{22} $	
	Mag.	Ang.	Mag.	Ang.	Mag.	Ang.	Mag.	Ang.
200	0.683	-50.1	10.186	138.3	0.049	62.0	0.773	-30.0
400	0.462	-86.9	7.472	114.6	0.071	54.3	0.556	-39.6
600	0.343	-113.1	5.618	100.9	0.086	53.8	0.448	-41.7
800	0.282	-133.6	4.407	91.7	0.101	55.3	0.392	-41.6
1000	0.249	-151.0	3.663	84.7	0.115	57.2	0.360	-41.7
1200	0.236	-166.6	3.128	78.7	0.131	58.9	0.339	-41.7
1400	0.233	179.7	2.759	73.1	0.150	60.1	0.330	-42.8
1600	0.234	168.3	2.457	68.2	0.168	60.0	0.319	-45.0
1800	0.238	158.6	2.224	63.4	0.185	60.0	0.311	-47.9
2000	0.251	149.6	2.038	59.4	0.203	60.4	0.302	-50.2

($V_{CE}=8V$, $I_C=20mA$, $Z_O=50\ \Omega$, $T_a=25\ ^\circ C$)

Frequency (MHz)	$ S_{11} $		$ S_{21} $		$ S_{12} $		$ S_{22} $	
	Mag.	Ang.	Mag.	Ang.	Mag.	Ang.	Mag.	Ang.
200	0.319	-91.9	18.338	116.7	0.033	65.3	0.494	-43.5
400	0.213	-134.2	10.303	99.2	0.054	68.9	0.312	-42.4
600	0.185	-160.0	7.111	90.3	0.076	70.8	0.258	-37.6
800	0.176	-178.2	5.415	84.3	0.098	71.2	0.236	-34.3
1000	0.174	167.8	4.400	79.2	0.120	71.1	0.228	-32.0
1200	0.178	156.8	3.712	74.8	0.143	70.3	0.226	-31.5
1400	0.186	147.5	3.236	70.3	0.168	68.7	0.226	-32.8
1600	0.194	139.7	2.874	66.3	0.190	66.6	0.223	-35.9
1800	0.199	133.7	2.583	62.6	0.211	64.9	0.216	-39.0
2000	0.215	127.8	2.369	58.8	0.232	63.5	0.211	-41.9

KTC3600S

S11e

V_{CE}=8V

I_C=5mA

T_a=25°C

(UNIT : Ω)

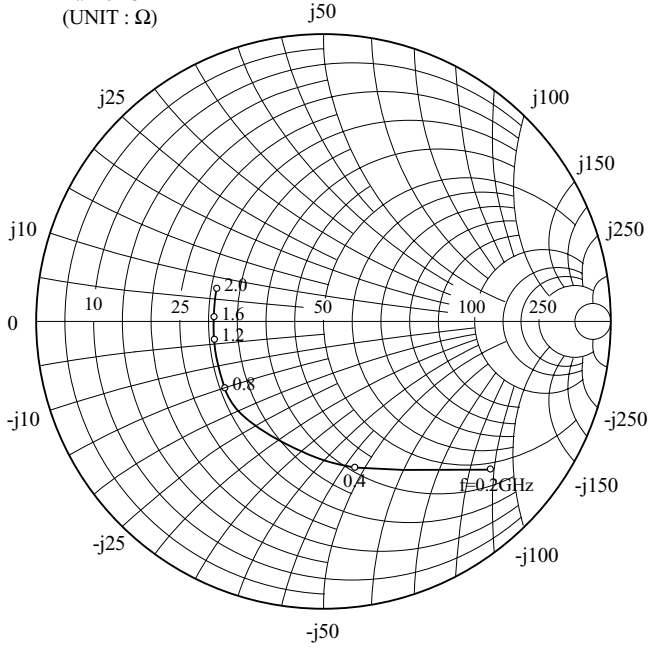

S21e

V_{CE}=8V

I_C=5mA

T_a=25°C

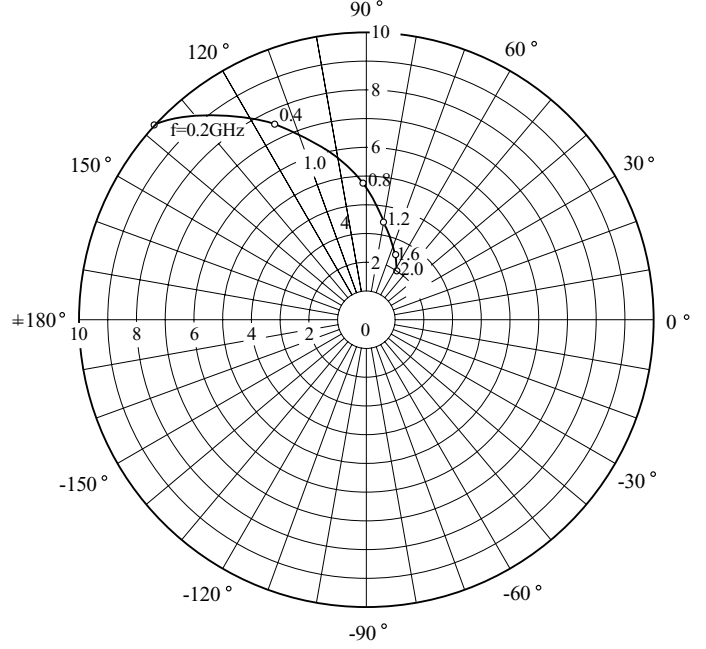

S12e

V_{CE}=8V

I_C=5mA

T_a=25°C

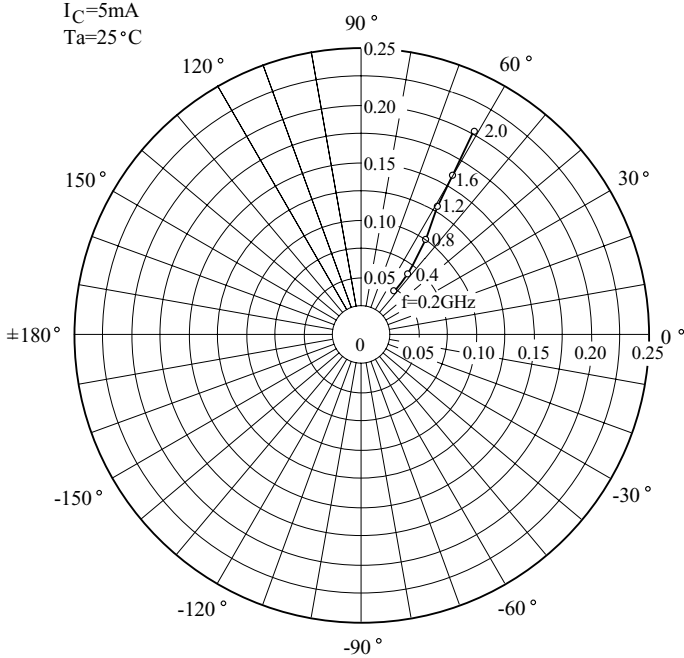

S22e

V_{CE}=8V

I_C=5mA

T_a=25°C

(UNIT : Ω)

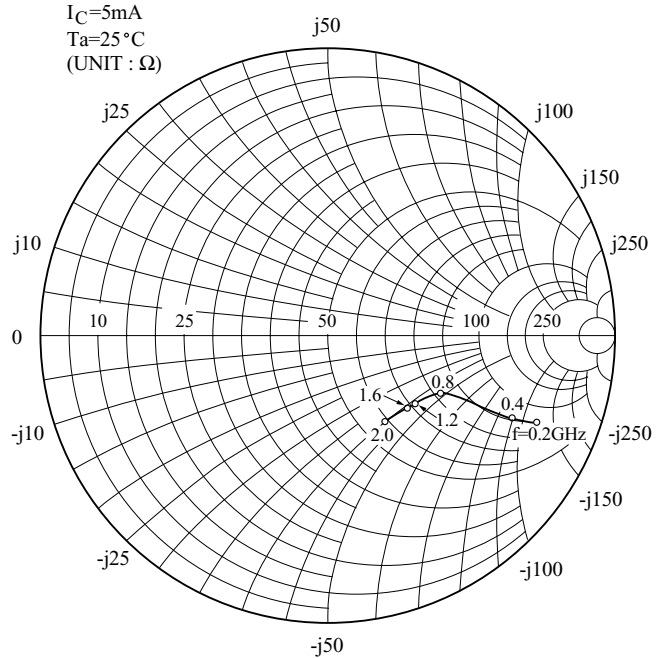

KTC3600S

S11e
 $V_{CE}=8V$
 $I_C=20mA$
 $T_a=25^\circ C$
 (UNIT : Ω)

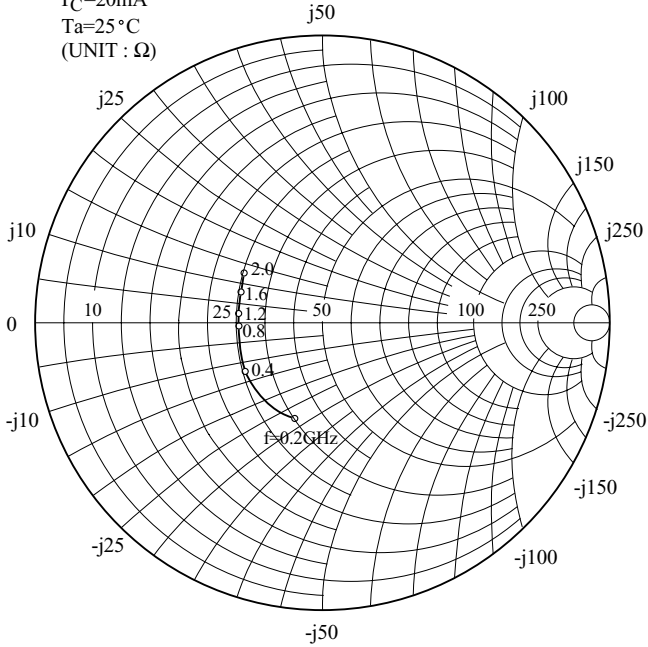

S21e
 $V_{CE}=8V$
 $I_C=20mA$
 $T_a=25^\circ C$

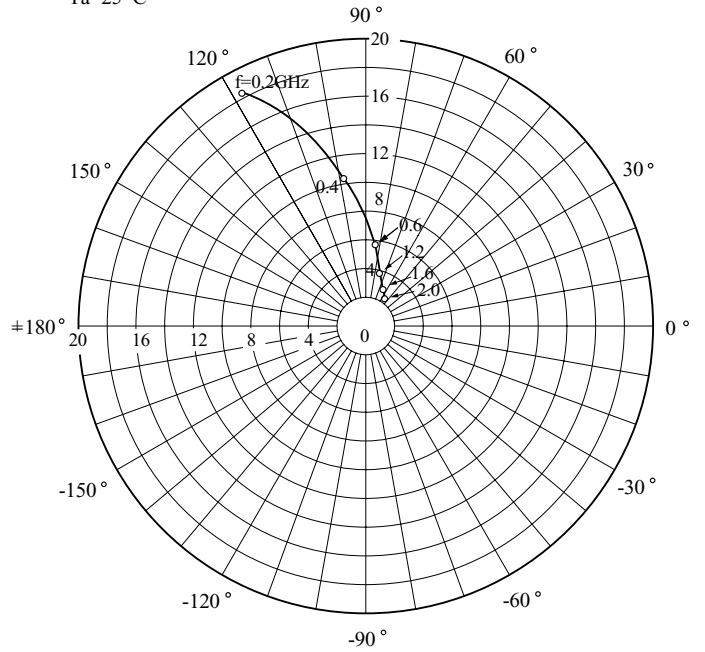

S12e
 $V_{CE}=8V$
 $I_C=20mA$
 $T_a=25^\circ C$

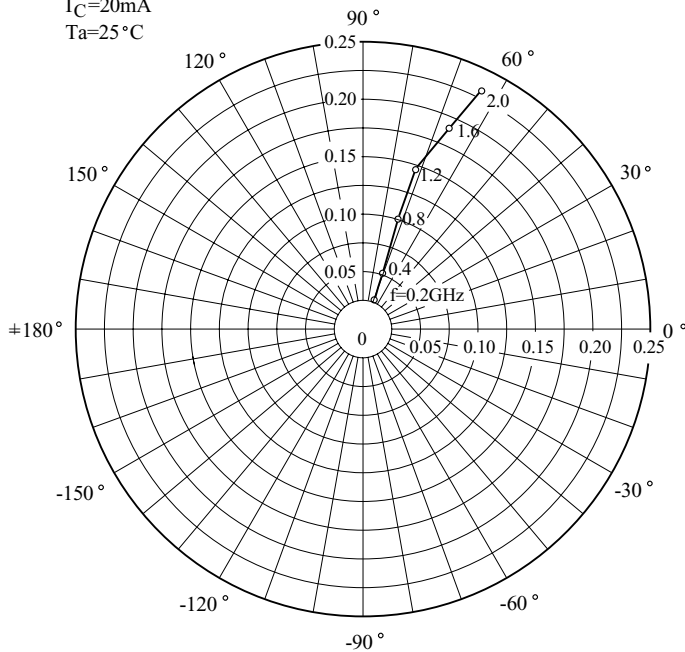

S22e
 $V_{CE}=8V$
 $I_C=20mA$
 $T_a=25^\circ C$
 (UNIT : Ω)

