

SERVICE MANUAL

BA-4 CHASSIS

<u>MODEL</u>	<u>COMMANDER</u>	<u>DEST.</u>	<u>CHASSIS NO.</u>
KV-29AL40	RM-Y165	E	SCC-S06J-A
KV-29AL40A	RM-Y165	E	SCC-S06H-A
KV-29AL40C	RM-Y165	E	SCC-S06K-A



KV-29AL40



RM-Y165

TRINITRON® COLOR TV
SONY®



SPECIFICATIONS		
-----------------------	--	--

	KV29AL40	KV29AL40A KV-29AL40C
Power requirements	120V,60Hz	220V, 50/60Hz
Number of inputs/outputs:		
Video ¹⁾	2	2
S Video ²⁾	—	—
Audio ³⁾	2	2
Audio Out ⁴⁾	1	1
Monitor Out	—	—
Speaker output (W)	10W x 2	10W x 2
Power Consumption (W):		
In use (max.)	170W	170W
In standby	2W	3W
Dimensions (W/H/D):		
(mm)	660.4 x 598 x 505.5mm	660.4 x 598 x 505.5mm
(in.)	26 x 23 ^{1/2} x 20in	26 x 23 ^{1/2} x 20in
Mass:		
(kg.)	42kg	42kg
(lbs.)	92 lbs. 8 oz.	92 lbs. 8 oz

¹⁾ 1 Vp-p 75 ohms unbalanced, sync negative

²⁾ Y: 1 Vp-p 75 ohms unbalanced, sync negative

C: 0.286 Vp-p (Burst signal), 75 ohms

³⁾ 500 mVrms (100% modulation), Impedance: 47 kilohms

⁴⁾ More than 408 mVrms at the maximum volume setting (variable)

Television system

American TV standard (all models except KV-29AL40A)
PAL-M, PAL-L, NTSC (KV-29AL40A only)

Channel coverage

VHF:2-13/UHF:14-69/CATV:1-125

Visible screen size

29-inch picture measured

Actual screen size

29-inch picture measured

Antenna

75 ohm external terminal for VHF/UHF

Supplied Accessories

Remote commander (including 2 size AA (R6) batteries)
RM-Y165

Optional Accessory

Connecting Cables:
VMC-810S/820S, VMC-720M, YC-15V/30V
TV Stand SU-27A3
VHF, UHF Mixer EAC-66

(●) ® SRS (SOUND RETRIEVAL SYSTEM)

The (●) SRS (SOUND RETRIEVAL SYSTEM) is manufactured by Sony Corporation under license from SRS Labs, Inc. It is covered by U.S. Patent No. 4,748,669. Other U.S. and foreign patents pending.

The word 'SRS' and the SRS symbol (●) are registered trademarks of SRS Labs, Inc.

BBE and BBE symbol are trademarks of BBE Sound, Inc. and are licensed by BBE Sound, Inc. under U.S. Patent No. 4,638,258 and 4,482,866.

Design and specifications are subject to change without notice.

TABLE OF CONTENTS

<u>Section</u>	<u>Title</u>	<u>Page</u>	<u>Section</u>	<u>Title</u>	<u>Page</u>
	Warnings and Caution	4			
	Self-Diagnostic Function	4			
	Safety Check Out Instructions	7			
1. GENERAL (in Spanish)			4. SAFETY RELATED ADJUSTMENTS		17
	Connecting and Installing the TV	8	5. CIRCUIT ADJUSTMENTS		
	Using the Remote Control	8	5-1. Electrical Adjustment by Remote Commander		19
	Programming the Channels	9	5-2. A Board Adjustments		22
	Watching the TV	9	6. DIAGRAMS		
	Other Functions	9	6-1. Block Diagrams		25
	Using the Audio Menu	11	6-2. Circuit Boards Location		28
	Troubleshooting	11	6-3. Printed Wiring Boards and Schematic Diagrams		28
2. DISASSEMBLY			• A Board		29
2-1. Rear Cover Removal		12	• CV Board		37
2-2. Control Switch Removal		12	• K Board		38
2-3. Chassis Assembly Removal		12	• E Board		40
2-4. Service Position		12	• HT Board		40
2-5. Picture Tube Removal		13	• HV Board		41
			• HZ Board		42
3. SET-UP ADJUSTMENTS			6-4. Semiconductors		43
3-1. Beam Landing		14	7. EXPLODED VIEWS		
3-2. Convergence		15	7-1. Chassis		44
3-3. Focus		16	7-2. Main Power Switch		45
3-4. Screen (G2)		16	(KV-29AL40A only)		
3-5. Method of Setting the Service Adjustment Mode		16	8. ELECTRICAL PARTS LIST		46
3-6. White Balance Adjustments		16			

WARNINGS AND CAUTIONS

CAUTION!

SHORT CIRCUIT THE ANODE OF THE PICTURE TUBE AND THE ANODE CAP TO THE METAL CHASSIS, CRT SHIELD, OR CARBON PAINTED ON THE CRT, AFTER REMOVING THE ANODE.

WARNING!!

AN ISOLATION TRANSFORMER SHOULD BE USED DURING ANY SERVICE TO AVOID POSSIBLE SHOCK HAZARD, BECAUSE OF LIVE CHASSIS. THE CHASSIS OF THIS RECEIVER IS DIRECTLY CONNECTED TO THE AC POWER LINE.

SAFETY-RELATED COMPONENT WARNING!!

COMPONENTS IDENTIFIED BY SHADING AND MARK \triangle ON THE SCHEMATIC DIAGRAMS, EXPLODED VIEWS AND IN THE PARTS LIST ARE CRITICAL FOR SAFE OPERATION. REPLACE THESE COMPONENTS WITH SONY PARTS WHOSE PART NUMBERS APPEAR AS SHOWN IN THIS MANUAL OR IN SUPPLEMENTS PUBLISHED BY SONY. CIRCUIT ADJUSTMENTS THAT ARE CRITICAL FOR SAFE OPERATION ARE IDENTIFIED IN THIS MANUAL. FOLLOW THESE PROCEDURES WHENEVER CRITICAL COMPONENTS ARE REPLACED OR IMPROPER OPERATION IS SUSPECTED.

ATTENTION

APRES AVOIR DECONNECTE LE CAP DE L'ANODE, COURT-CIRCUITER L'ANODE DU TUBE CATHODIQUE ET CELUI DE L'ANODE DU CAP AU CHASSIS METALLIQUE DE L'APPAREIL, OU AU COUCHE DE CARBONE PEINTE SUR LE TUBE CATHODIQUE OU AU BLINDAGE DU TUBE CATHODIQUE.

ATTENTION!!

AFIN D'EVITER TOUT RESQUE D'ELECTROCUTION PROVENANT D'UN CHÂSSIS SOUS TENSION, UN TRANSFORMATEUR D'ISOLEMENT DOIT ETRE UTILISÉ LORS DE TOUT DÉPANNAGE. LE CHÂSSIS DE CE RÉCEPTEUR EST DIRECTEMENT RACCORDÉ À L'ALIMENTATION SECTEUR.

ATTENTION AUX COMPOSANTS RELATIFS A LA SECURITE!!

LES COMPOSANTS IDENTIFIES PAR UNE TRAME ET PAR UNE MARQUE \triangle SUR LES SCHEMAS DE PRINCIPE, LES VUES EXPLOSEES ET LES LISTES DE PIECES SONT D'UNE IMPORTANCE CRITIQUE POUR LA SECURITE DU FONCTIONNEMENT. NE LES REMPLACER QUE PAR DES COMPOSANTS SONY DONT LE NUMERO DE PIECE EST INDIQUE DANS LE PRESENT MANUEL OU DANS DES SUPPLEMENTS PUBLIES PAR SONY. LES REGLAGES DE CIRCUIT DONT L'IMPORTANCE EST CRITIQUE POUR LA SECURITE DU FONCTIONNEMENT SONT IDENTIFIES DANS LE PRESENT MANUEL. SUIVRE CES PROCEDURES LORS DE CHAQUE REMPLACEMENT DE COMPOSANTS CRITIQUES, OU LORSQU'UN MAUVAIS FONCTIONNEMENT SUSPECTE.

SELF-DIAGNOSTIC FUNCTION

The units in this manual contain a self-diagnostic function. If an error occurs, the STANDBY/TIMER lamp will automatically begin to flash. The number of times the lamp flashes translates to a probable source of the problem. A definition of the STANDBY/TIMER lamp flash indicators is listed in the instruction manual for the user's knowledge and reference. If an error symptom cannot be reproduced, the remote commander can be used to review the failure occurrence data stored in memory to reveal past problems and how often these problems occur.

1. DIAGNOSTIC TEST INDICATORS

When an error occurs, the STANDBY/TIMER lamp will flash a set number of times to indicate the possible cause of the problem. If there is more than one error, the lamp will identify the first of the problem areas.

Results for all of the following diagnostic items are displayed on screen. No error has occurred if the screen displays a "0".

Diagnostic Item Description	No. of times STANDBY/TIMES lamp flashes	Self-diagnostic display/ Diagnostic result	Probable Cause Location	Detected Symptoms
• Power does not turn on	Does not light	—	<ul style="list-style-type: none"> • Power cord is not plugged in. • Fuse is burned out (F5050). (E Board) 	<ul style="list-style-type: none"> • Power does not come on. • No power is supplied to the TV. • AC power supply is faulty.
• +B overcurrent (OCP)	2 times	2:0 or 2:1	<ul style="list-style-type: none"> • H.OUT (Q502) is shorted. (A Board) • IC1701, Q946, Q947 is shorted. (C Board) 	<ul style="list-style-type: none"> • Power does not come on. • Load on power line is shorted.
• Vertical deflection stopped	4 times	4:0 or 4:1	<ul style="list-style-type: none"> • +13V is not supplied. (A Board) • IC 541 is faulty (A Board) 	<ul style="list-style-type: none"> • Has entered standby state after horizontal raster. • Vertical deflection pulse is stopped. • Power line is shorted or power supply is stopped.
• White balance failure (not balanced)	5 times	5:0 or 5:1	<ul style="list-style-type: none"> • Video OUT (Q306, Q307, Q308) is faulty. (A Board) • IC301 is faulty. (A Board) • G2 is improperly adjusted. (Note 2) 	<ul style="list-style-type: none"> • No raster is generated. • CRT cathode current detection

Note 1: If a +B overcurrent is detected, stoppage of the vertical deflection is detected simultaneously.

The symptom that is diagnosed first by the microcontroller is displayed on the screen.

Note 2: Refer to Screen (G2) Adjustment in Section 3-4 of this manual.

2. DISPLAY OF STANDBY/TIMER LIGHT FLASH COUNT

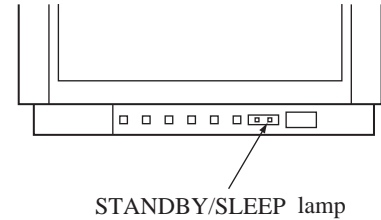
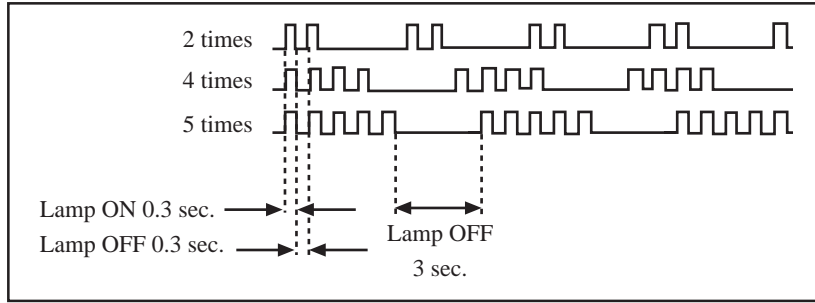

Diagnostic Item	Flash Count*
+B overcurrent	2 times
Vertical deflection stopped	4 times
White balance failure	5 times

* One flash count is not used for self-diagnostic.

3. STOPPING THE STANDBY/TIMER FLASH

Turn off the power switch on the TV main unit or unplug the power cord from the outlet to stop the STANDBY/TIMER lamp from flashing.

4. SELF-DIAGNOSTIC SCREEN DISPLAY

For errors with symptoms such as "power sometimes shuts off" or "screen sometimes goes out" that cannot be confirmed, it is possible to bring up past occurrences of failure for confirmation on the screen:

[To Bring Up Screen Test]

In standby mode, press buttons on the remote commander sequentially in rapid succession as shown below:

Screen display → Channel [5] → Sound volume [−] → Power ON
↑

Note that this differs from entering the service mode (sound volume [+]).

Self-Diagnostic screen display:

SELF DIAGNOSTIC			
2:		0	←-----Numeral "0" means that no fault has been detected.
3:	N/A	0	
4:		0	
5:		1	←-----Numeral "1" means a fault has been detected one time only.
101:	N/A	0	

5. HANDLING OF SELF-DIAGNOSTIC SCREEN DISPLAY

Since the diagnostic results displayed on the screen are not automatically cleared, always check the self-diagnostic screen during repairs. When you have completed the repairs, clear the result display to "0".

Unless the result display is cleared to "0", the self-diagnostic function will not be able to detect subsequent faults after completion of the repairs.

[Clearing the result display]

To clear the result display to "0", press buttons on the remote commander sequentially as shown below when the diagnostic screen is being displayed.

Channel [8] → ENTER

[Quitting Self-diagnostic screen]

To quit the entire self-diagnostic screen, turn off the power switch on the remote commander or the main unit.

6. SELF-DIAGNOSTIC CIRCUIT

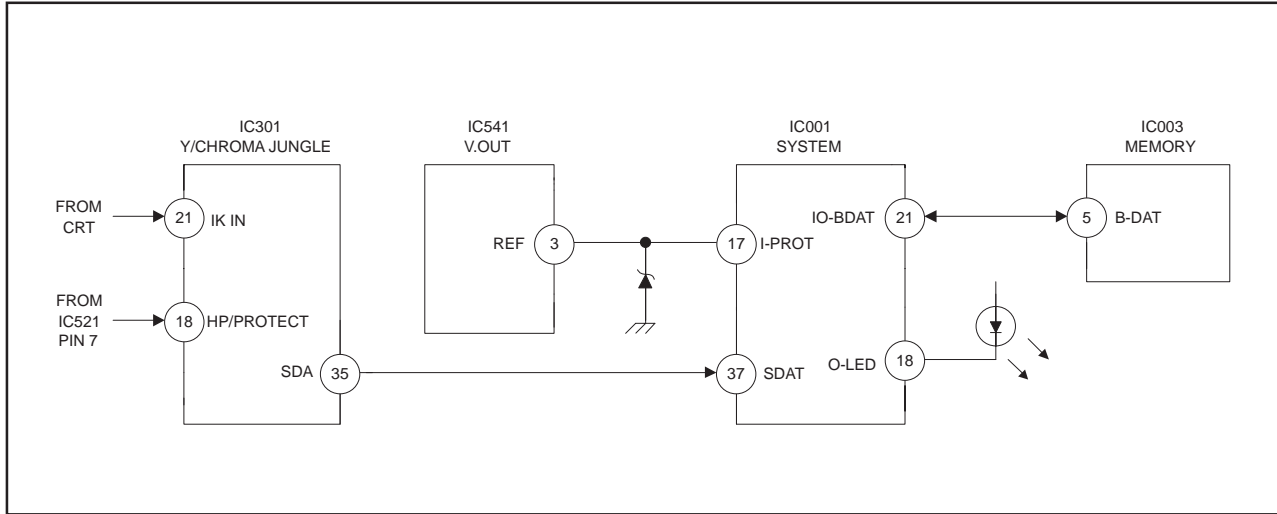

+B overcurrent (OCP)

Occurs when an overcurrent on the +B(115V) line is detected by pin 18 of IC301. If the voltage to pin 18 of IC301 is less than 1V when V.SYNC is more than seven verticals in a period, the unit will automatically turn off.

Vertical deflection stopped

Occurs when an absence of the vertical deflection pulse is detected by pin 17 of IC001. Power supply will shut down when waveform interval exceeds 2 seconds.

White balance failure

If the RGB levels* do not balance within 2 seconds after the power is turned on, this error will be detected by IC301. TV will stay on, but there will be no picture.

*(Refers to the RGB levels of the AKB detection Ref pulse that detects IK.)

SAFETY CHECK-OUT

After correcting the original service problem, perform the following safety checks before releasing the set to the customer:

1. Check the area of your repair for unsoldered or poorly-soldered connections. Check the entire board surface for solder splashes and bridges.
2. Check the interboard wiring to ensure that no wires are "pinched" or contact high-wattage resistors.
3. Check that all control knobs, shields, covers, ground straps, and mounting hardware have been replaced. Be absolutely certain that you have replaced all the insulators.
4. Look for unauthorized replacement parts, particularly transistors, that were installed during a previous repair. Point them out to the customer and recommend their replacement.
5. Look for parts which, though functioning, show obvious signs of deterioration. Point them out to the customer and recommend their replacement.
6. Check the line cords for cracks and abrasion. Recommend the replacement of any such line cord to the customer.
7. Check the B+ and HV to see if they are specified values. Make sure your instruments are accurate; be suspicious of your HV meter if sets always have low HV.
8. Check the antenna terminals, metal trim, "metallized" knobs, screws, and all other exposed metal parts for AC Leakage. Check leakage as described below.

LEAKAGE TEST

The AC leakage from any exposed metal part to earth ground and from all exposed metal parts to any exposed metal part having a return to chassis, must not exceed 0.5 mA (500 microampere). Leakage current can be measured by any one of three methods.

1. A commercial leakage tester, such as the Simpson 229 or RCA WT-540A. Follow the manufacturers' instructions to use these instructions.
2. A battery-operated AC milliammeter. The Data Precision 245 digital multimeter is suitable for this job.
3. Measuring the voltage drop across a resistor by means of a VOM or battery-operated AC voltmeter. The "limit" indication is 0.75 V, so analog meters must have an accurate low voltage scale. The Simpson's 250 and Sanwa SH-63Trd are examples of passive VOMs that are suitable. Nearly all battery operated digital multimeters that have a 2V AC range are suitable. (See Fig. A)

HOW TO FIND A GOOD EARTH GROUND

A cold-water pipe is guaranteed earth ground; the cover-plate retaining screw on most AC outlet boxes is also at earth ground. If the retaining screw is to be used as your earth-ground, verify that it is at ground by measuring the resistance between it and a cold-water pipe with an ohmmeter. The reading should be zero ohms. If a cold-water pipe is not accessible, connect a 60-100 watts trouble light (not a neon lamp) between the hot side of the receptacle and the retaining screw. Try both slots, if necessary, to locate the hot side of the line, the lamp should light at normal brilliance if the screw is at ground potential. (See Fig. B)

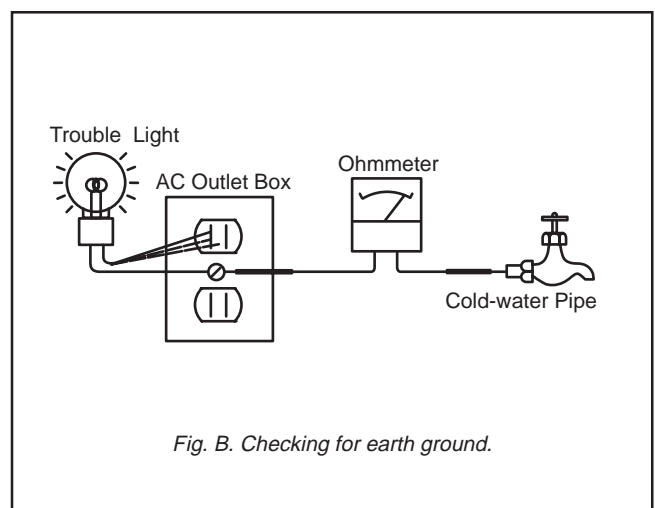
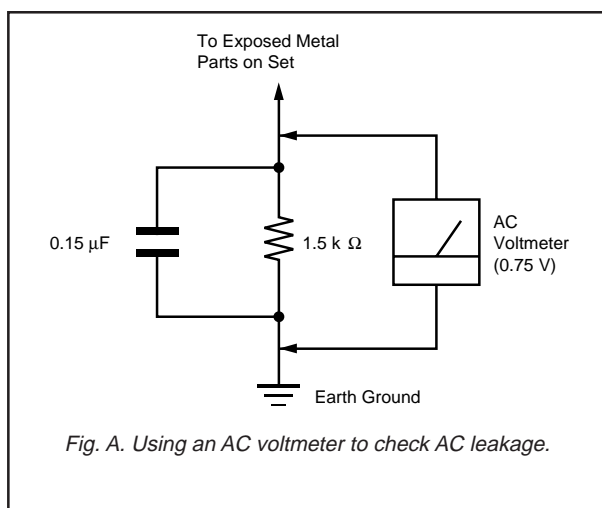

SECTION 2 DISASSEMBLY

2-1. REAR COVER REMOVAL

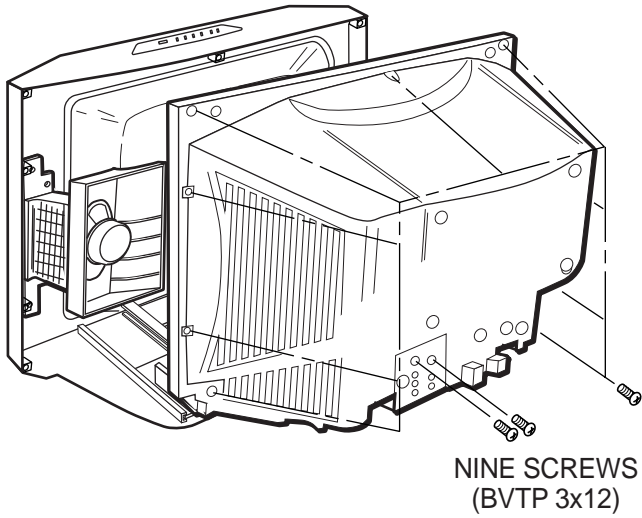

2-2. CONTROL SWITCH REMOVAL

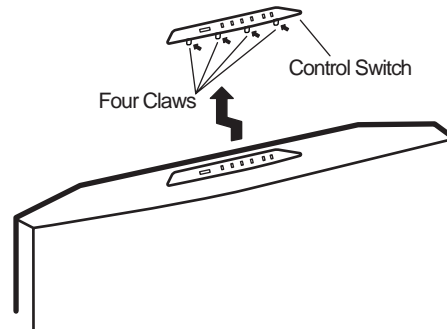

2-3. CHASSIS ASSEMBLY REMOVAL

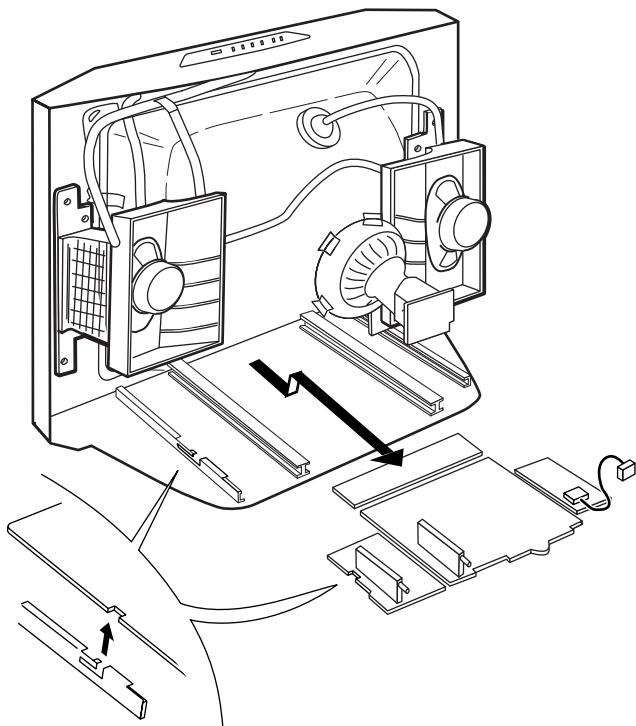

2-4. SERVICE POSITION

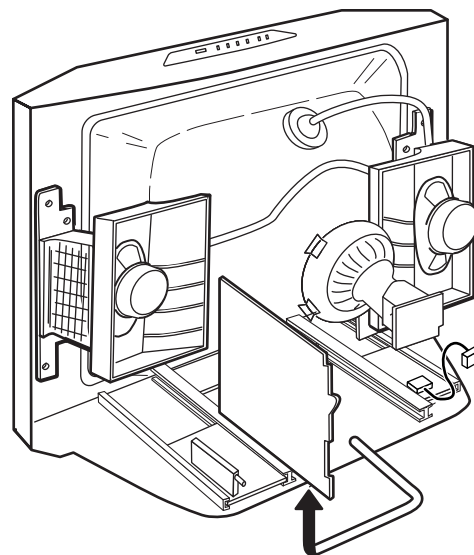

2-5. PICTURE TUBE REMOVAL

WARNING: BEFORE REMOVING ANODE CAP

H.V. remains in the CRT even after the power is disconnected. Discharge the CRT before attempting to remove the anode cap to avoid electrical shock. Short between the anode and CRT coating the earth ground strap.

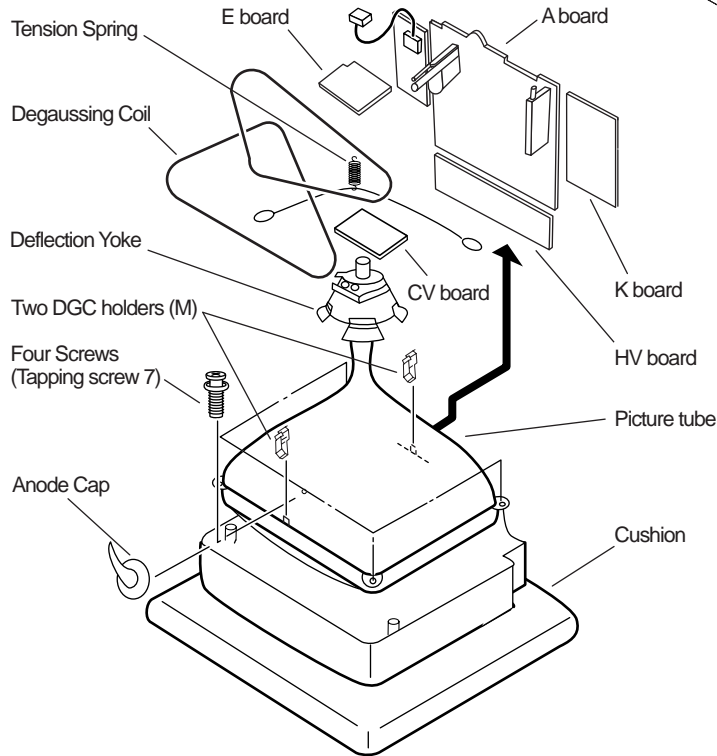
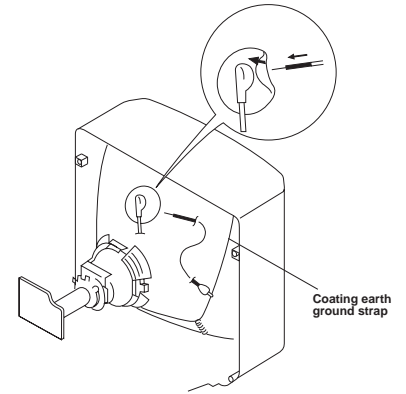

ANODE-CAP REMOVAL

NOTE: Short circuit the anode of the picture tube and the anode cap to the metal chassis, CRT shield or carbon painted on the CRT, after removing the anode.

REMOVAL PROCEDURES

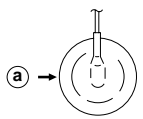

- ① Turn up one side of the rubber cap in the direction indicated by the arrow ①.

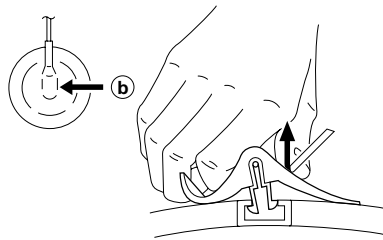

- ② Use your thumb to pull the rubber cap firmly in the direction indicated by the arrow ②.

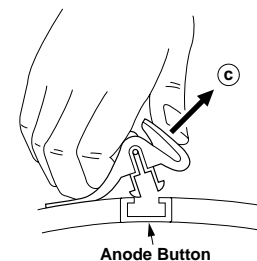

- ③ When one side of the rubber cap separates from the anode button, the anode-cap can be removed by turning the rubber cap and pulling it in the direction of the arrow ③.

HOW TO HANDLE AN ANODE-CAP

- ① Do not use sharp objects which may cause damage to the surface of the anode-cap.
- ② Do not squeeze the rubber covering too hard to avoid damaging the anode-cap. A material fitting called a shatter-hook terminal is built into the rubber.
- ③ Do not force turn the foot of the rubber cover. This may cause the shatter-hook terminal to protrude and damage the rubber.

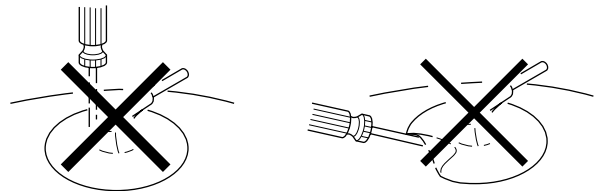

SECTION 3 SET-UP ADJUSTMENTS

The following adjustments should be made when a complete realignment is required or a new picture tube is installed. These adjustments should be performed with rated power supply voltage unless otherwise noted.

The controls and switch should be set as follows unless otherwise noted:

PICTURE control normal

BRIGHTNESS control normal

Perform the adjustments in order as follows:

1. Beam Landing
2. Convergence
3. Focus
4. Screen (G2) and White Balance

Note: Test Equipment Required

1. Color Bar Pattern Generator
2. Degausser
3. DC Power Supply
4. Digital Multimeter

3-1. BEAM LANDING

Preparation:

- Feed in the white pattern signal.
- Before starting, degauss the entire screen.

1. Input a raster signal with the pattern generator.
2. Loosen the deflection yoke mounting screw, and set the purity control to the center as shown in Fig.2.
3. Turn the raster signal of the pattern generator to green.
4. Move the deflection yoke backward, and adjust with the purity control so that green is in the center and red and blue are at the sides evenly. (Fig.3)
5. Move the deflection yoke forward, and adjust so that the entire screen becomes green. (Fig.1)
6. Switch over the raster signal to red and blue and confirm the condition.
7. When the position of the deflection yoke is determined, tighten it with the deflection yoke mounting screw.
8. When landing at the corner is not right, adjust by using the disk magnets. (Fig.4)

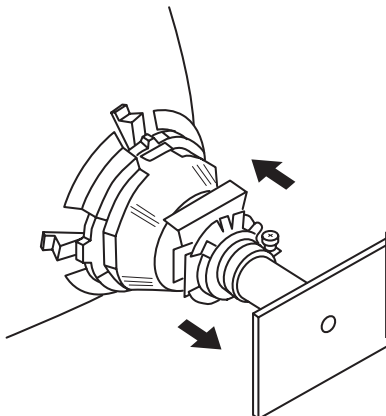

Fig. 1

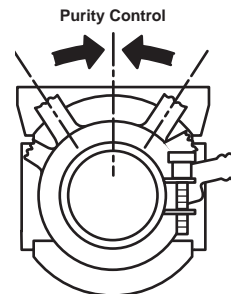

Fig. 2

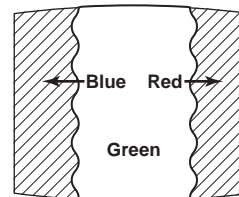

Fig. 3

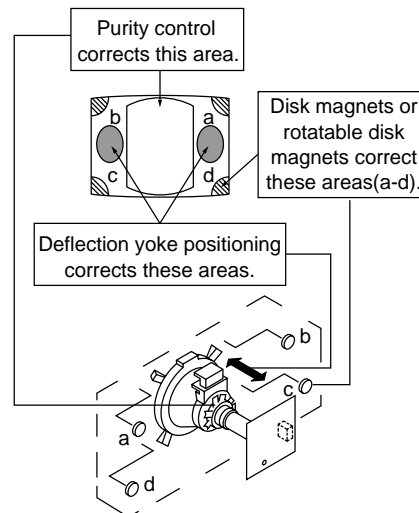

Fig. 4

3-2. CONVERGENCE

Preparation:

- Before starting, perform FOCUS, V. LIN and V. SIZE adjustments.
- Set BRIGHTNESS control to minimum.
- Feed in dot pattern.

(1) Vertical Static Convergence

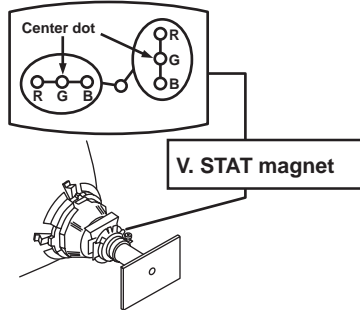
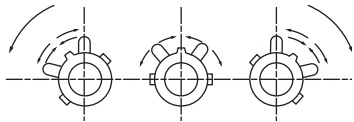

Fig. 5

1. Adjust V. STAT magnet to converge red, green and blue dots in the center of the screen. (Vertical movement)

Tilt the V. STAT magnet and adjust static convergence to open or close the V. STAT magnet.



2. When the V. STAT magnet is moved in the direction of arrow a and b, red, green, and blue dots move as shown below:

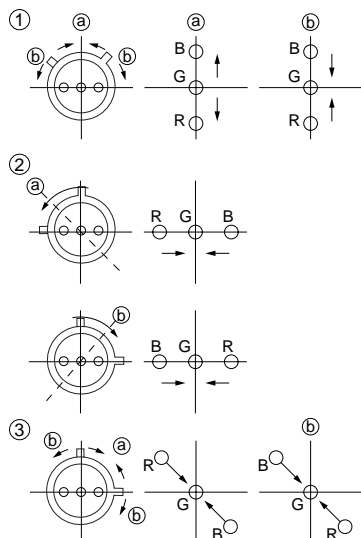

If the blue dot does not converge with red and green dots, perform the following steps:

- Move BMC magnet (a) to correct insufficient H. Static convergence.
- Rotate BMC magnet (b) to correct insufficient V. Static convergence.

In either case, repeat Beam Landing Adjustment.

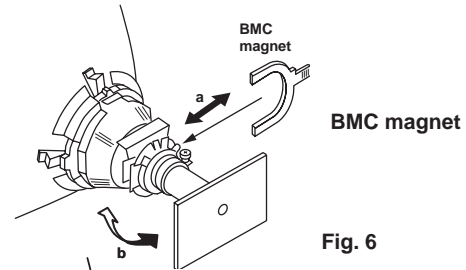

Fig. 6

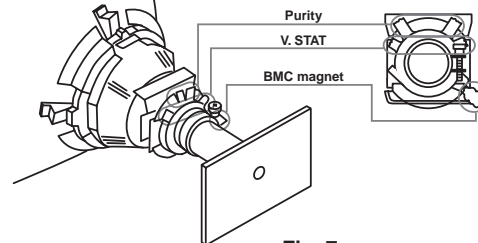

Fig. 7

(2) Dynamic Convergence Adjustment

Preparation:

- Before starting, perform Horizontal and Vertical Static Convergence Adjustment.

1. Slightly loosen deflection yoke screw.
2. Remove deflection yoke spacers.
3. Move the deflection yoke for best convergence as shown below. (Fig. 8)
4. Tighten the deflection yoke screw.
5. Install the deflection yoke spacers.

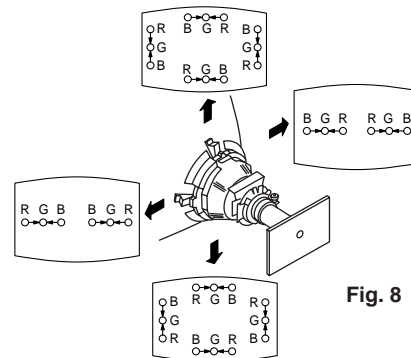

Fig. 8

(3) Screen-corner Convergence

Fig. 9

Affix a permalloy assembly corresponding to the misconverged areas:

**3-3. FOCUS**

1. Adjust FOCUS control for best picture.

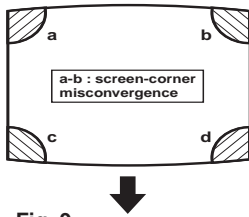
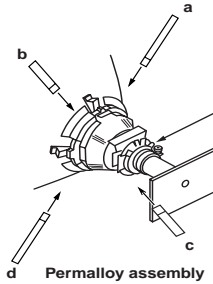
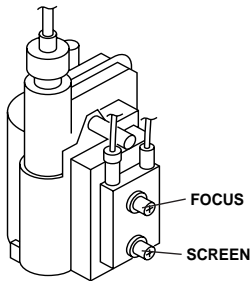

Fig. 10

3-4. SCREEN (G2)

1. Input a dots pattern.
2. Set the PICTURE and BRIGHT controls at minimum and COLOR control at normal.
3. Adjust SBRT, GCUT, BCUT in service mode with an oscilloscope as shown in Fig. 11 so that voltages on the red, green, and blue cathodes are 170Vdc.

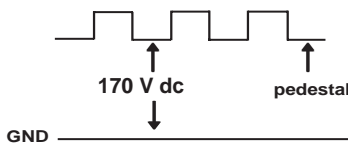
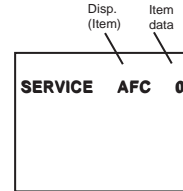

Fig. 11

4. Observe the screen and adjust SCREEN (G2) VR to obtain the faintly visible background of dot signal.

3-5. METHOD OF SETTING THE SERVICE ADJUSTMENT MODE**(1) SERVICE MODE PROCEDURE**

1. Standby mode. (Power off)
2. **DISPLAY** → **5** → **VOL (+)** → **POWER** on the Remote Commander. (Press each button within a second.)

(2) SERVICE ADJUSTMENT MODE IN

3. The CRT displays the item being adjusted.
4. Press **1** or **4** on the Remote Commander to select the item.
5. Press **3** or **6** on the Remote Commander to change the data.
6. Press **MUTING** then **ENTER** to write into memory.

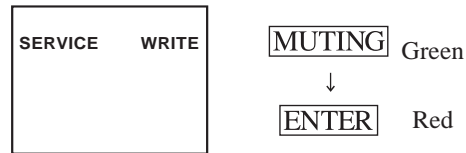
(3) SERVICE ADJUSTMENT MODE MEMORY

7. Turn set off and on to exit.

3-6. WHITE BALANCE ADJUSTMENTS

1. Input an entire white signal.
2. Set to Service adjustment Mode.
3. Set DCOL to "0"
4. Set the PICTURE and BRIGHT to minimum.
5. Adjust with SBRT if necessary.
6. Select GCUT and BCUT with **1** and **4**.
7. Adjust with **3** and **6** for the best white balance.
8. Set the PICTURE and BRIGHT to maximum.
9. Select GDRV and BDRV with **1** and **4**.
10. Adjust with **3** and **6** for the best white balance.
11. Reset DCOL to "1".
12. Write into the memory by pressing **MUTING** then **ENTER**.

SECTION 4 SAFETY RELATED ADJUSTMENTS

A BOARD

▣ R584 CONFIRMATION METHOD (HV HOLD-DOWN CONFIRMATION) AND READJUSTMENTS

The following adjustments should always be performed when replacing the following components which are marked with ▣ on the schematic diagram:

DY, C511, C572, C573, C574, C575, D573, D574, R582, R583, R585, R586, R578, R579, T504, IC301, IC521, IC603, C507, C508, C509, C515, C520, L591, L501

(1) Preparation before Confirmation

Using Variac, apply AC input voltage: 120 ± 2 VAC
(or 220 ± 2 VAC for KV-29AL40A/C)

- 1) Turn the POWER switch ON.
- 2) Input a white signal and set the PICTURE and BRIGHT controls to maximum.
- 3) Confirm that the voltage between C574 (+) or TP503 and ground is more than: 105VDC.

(2) Hold-down Operation Confirmation

- 1) Connect the current meter between Pin 11 of the FBT (T504) and the PCB land where Pin 11 would normally attach. (see figure 1.0 on next page)
- 2) Input a dot signal and set PICTURE and BRIGHTNESS to minimum: $I_{ABL} = 100 \pm 100 \mu\text{A}$
- 3) Confirm the voltage of A board TP-600 is 135 ± 3 VDC
- 4) Connect the Digital Voltmeter and the DC power supply via diode 1SS119 to C574 (+). (See figure 1.0 on next page.)
- 5) Increase the DC power voltage gradually until the picture blanks out.
- 6) Turn DC power source off immediately.
- 7) Read the digital voltmeter indication.

STANDARD

Less than or equal to: 141.3 VDC

- 8) Input a white signal and set PICTURE and BRIGHTNESS to maximum: $I_{ABL} = 1750 \pm 100 \mu\text{A}$
- 9) Repeat steps from (4) to (7).

STANDARD

Less than or equal to: 141.3 VDC

(3) Hold-down Readjustment

If the current setting indicated in step 2-2 cannot be met, readjustment should be performed by altering the resistance value of R584, a component marked with ▣.

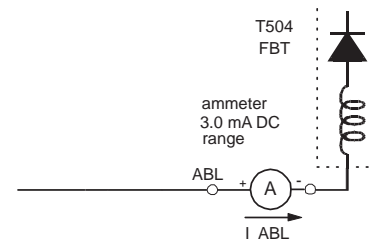

B+ VOLTAGE CONFIRMATION AND ADJUSTMENT

The following adjustments should always be performed when replacing the following components which are marked with ▣ on the schematic diagram:

IC603, IC601, R699

- 1) Using Variac, apply AC input voltage: 130 ± 2.0 VAC (or 220.0 ± 2.0 VAC for KV-29AL40A/C).
- 2) Input a dot signal.
- 3) Set the PICTURE control and the BRIGHT control to minimum.
- 4) Set to service adjustment mode.
- 5) Select PADJ with **[1]** and **[4]**.
- 6) Adjust with **[6]** to the 0 level.
- 7) Confirm the voltage of A BOARD TP-600 is less than 138 VDC.
- 8) If step 7 is not satisfied, replace the components, repeat the above steps.
- 9) Adjust with **[3]** and **[6]** for: 135 ± 3 VDC
- 10) Write into the memory by pressing **[MUTING]** then **[ENTER]**.

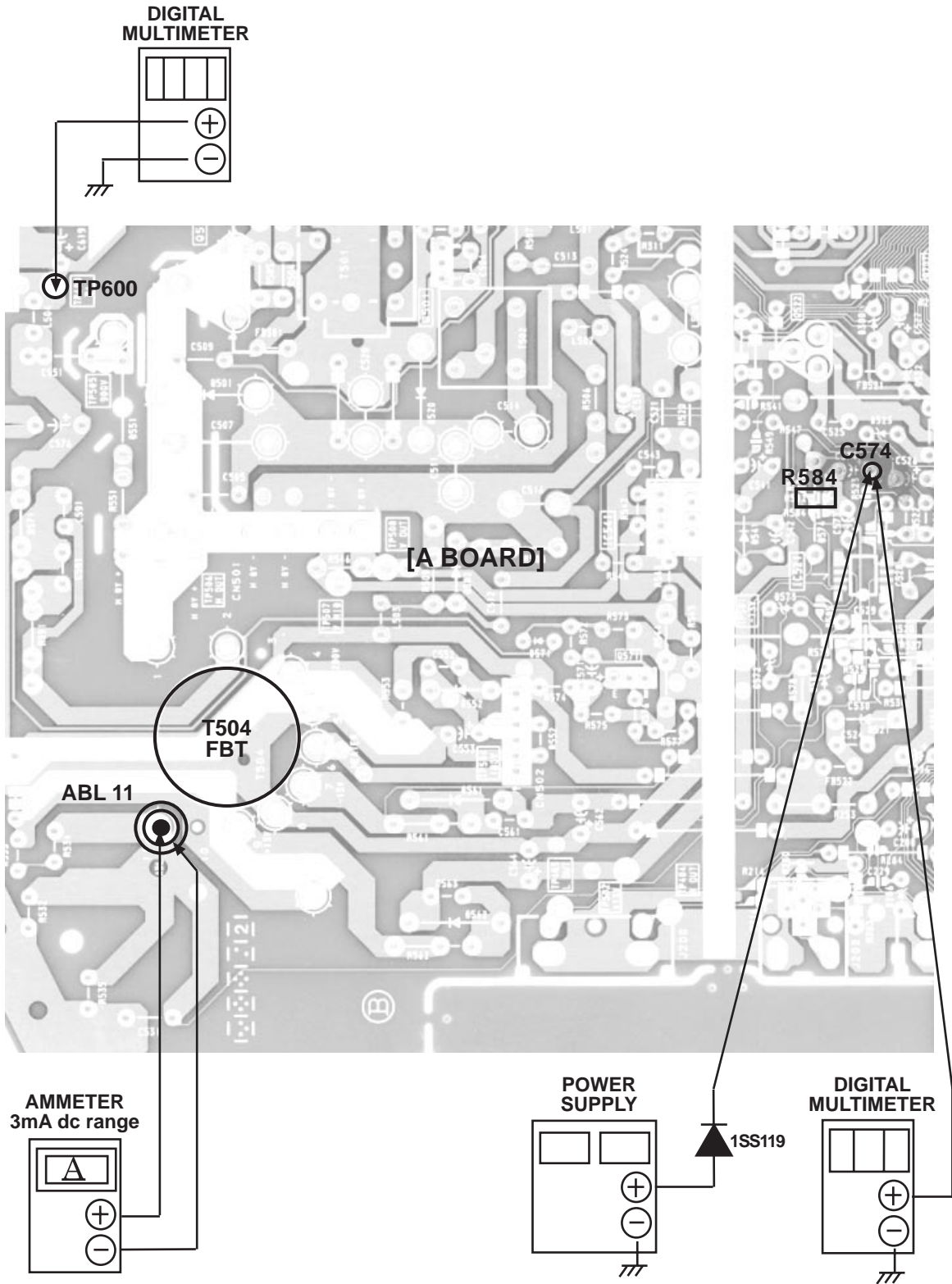

SECTION 5 CIRCUIT ADJUSTMENTS

5-1. ELECTRICAL ADJUSTMENT BY REMOTE COMMANDER

Use Remote Commander (RM-Y165) to perform circuit adjustments on this model.

NOTE: Test Equipment Required:

1. Pattern Generator
2. Frequency Counter
3. Digital Multimeter
4. Audio OSC

7. Press **[8]** then **[ENTER]** on the Remote Commander to initialize.

SERVICE RESET

Carry out step 7 when adjusting IDs 0 to 4 and when replacing and adjusting IC003.

(1) Method of Setting the Service Adjustment Mode

SERVICE MODE PROCEDURE

1. Standby mode. (Power off)
2. **[DISPLAY]** → **[5]** → **[VOL(+)]** → **[POWER]** on the Remote Commander. (Press each button within a second.)

SERVICE ADJUSTMENT MODE IN

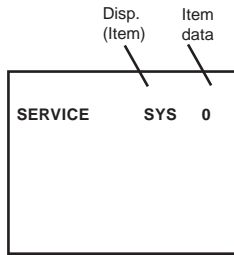

3. The CRT displays the item being adjusted.
4. Press **[1]** or **[4]** on the Remote Commander to select the item.
5. Press **[3]** or **[6]** on the Remote Commander to change the data.
6. Press **[MUTING]** then **[ENTER]** to write into memory.

SERVICE ADJUSTMENT MODE MEMORY

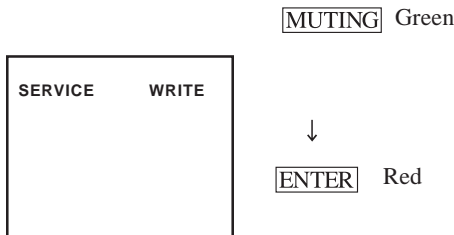

8. Turn set off and on to exit.

(2) Memory Write Confirmation Method

1. After adjustment, pull out the plug from the AC outlet, then replace the plug in the AC outlet again.
2. Turn the power switch ON and set to service mode.
3. Call the adjusted items again to confirm they were adjusted.

(3) Adjust Buttons and Indicator

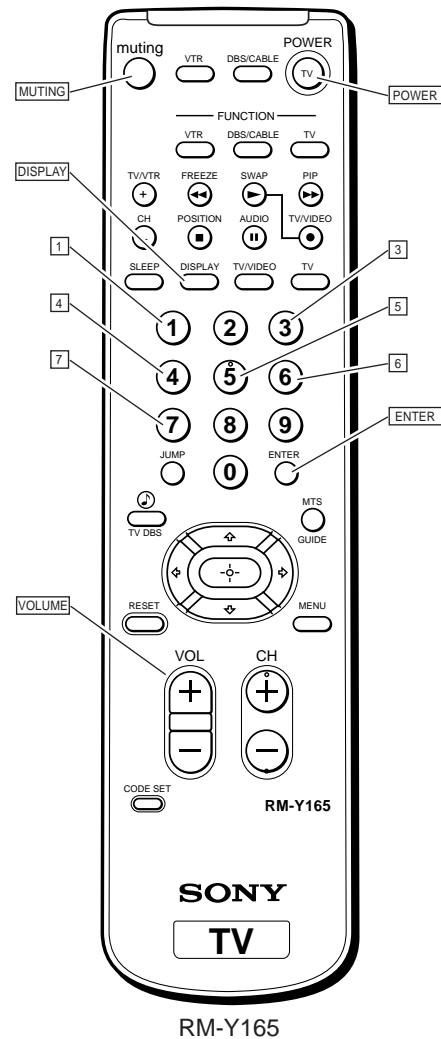

(4) Item of Adjustments

NO.	ITEM	FUNCTION	DATA RANGE	INITIAL DATA				AVERAGE DATA
				NTSC	PAL-M	PAL-N	VIDEO	
1	HSIZ	HORIZONTAL AMP. ADJ.	0-63	45	45	45		48
2	HPOS	HORIZONTAL POS. ADJ.	0-63	10	10	10		10
3	VBOW	VRT LINE BOWING ADJ.	0-15	6				6
4	VANG	VRT LINE BOW SLANT ADJ.	0-15	9				5
5	TRAP	HORIZ. TRAPEZOID ADJ.	0-15	7				5
6	PAMP	HORIZ. PIN DISTORTION ADJ.	0-63	21	20	20		30
7	CPIN	SAME AS PAMP-SCRN TP/BTM	0-63	40	40	40		30
8	VSIZ	VERTICAL AMP. ADJUST	0-63	39	31	38		35
9	VPOS	VERTICAL POSITION ADJ.	0-63	37	35	35		35
10	VLIN	VERTICAL LINEARITY ADJ.	0-15	7	6	6		6
11	SCOR	VERTICAL AMOUNT ADJ.	0-15	8	8	8		8
12	VZOM	16:9 CRT Z MODE ON/OFF	0,1	0				0
13	EHT	VRT HI-VOLT. CORRECTION	0-15	4				4
14	ASP	ASPECT RATIO CONTROL	0-63	47				47
15	SCRL	16:9 CRT Z MODE TRAN SCRL	0-63	31				31
16	HBLK	RGB OUT WIDTH CONTROL	0,1	1				1
17	LBLK	LEFT SCREEN HBLK CONTROL	0-15	15				15
18	RBLK	RGT SCREEN HBLK CONTROL	0-15	3				3
19	VUSN	V SAW WAVEFORM COMPRES	0,1	0				0
20	HDW	H. DRIVE PULSE WIDTH	0,1	0				0
21	EWDC	EW/DC ADJUST	0,1	0				0
22	LVLN	SCREEN BTM VRT LIN ADJUST	0-15	0				0
23	UVLN	SCREEN TOP VRT LIN ADJUST	0-15	0				0
24	RDRV	R OUTPUT DRIVE CONTROL	0-63	42				40
25	GDRV	G OUTPUT DRIVE CONTROL	0-63	32				35
26	BDRV	B OUTPUT DRIVE CONTROL	0-63	28				35
27	RCUT	R OUTPUT CUTOFF CONTROL	0-15	9				7
28	GCUT	G OUTPUT CUTOFF CONTROL	0-15	4				5
29	BCUT	B OUTPUT CUTOFF CONTROL	0-15	4				5
30	DCOL	DYNAMIC COLOR ON/OFF	0,1	0				1
31	SHUE	SUB HUE	0-31	14				8
32	SCOL	SUB COLOR	0-31	18	14	14		14
33	SBRT	SUB BRIGHTNESS	0-31	14				12
34	RON	R OUTPUT ON/OFF	0,1	1				1
35	GON	G OUTPUT ON/OFF	0,1	1				1
36	BON	B OUTPUT ON/OFF	0,1	1				1
37	AXPL	AXIS PAL	0,1	0				0
38	AXNT	AXIS NTSC	0,1	0				0
39	CBPF	CHROMA BPF ON/OFF	0,1	0*, 1**				
40	CTRP	Y TRAP FILTER ON/OFF	0,1	1*, 0**				
41	COFF	COLOR ON/OFF	0,1	0				0
42	KOFF	SET COLOR KILLER	0,1	0				0
43	SSHP	SUB SHARPNESS	0-15	7				6
44	SHPF	SHARPNESS CIRCUIT F0	0,1	1			1	1
45	PREL	PRE/OVR SHOOT SWITCHING	0,1	1				1
46	Y-DC	DC TRANS RATIO SWITCHING	0,1	1				1
47	GAMM	GAMMA CORRECTION AMNT	0-3	0				0
48	ABLM	ABL MODE SWITCHING	0,1	1				1
49	VTH	ABL C D VTH SWITCHING	0,1	1				1
50	YDEL	Y DELAY TIME CONTROL	0-15	7				7
51	NCOL	NO COLOR ID	0,1	1				1
52	FSC	FSC OUT ON/OFF	0,1	1*, 0**				
53	K-ID	KILLER ID CONTROL SW	0,1	0				0
54	HOSC	H VCO OSCILLATION FREQ	0-15	7				7
55	VSS	V SYNC SLICE LEVEL	0,1	0				0
56	HSS	H SYNC SLICE LEVEL	0,1	0				0
57	HMSK		0,1	1				1
58	VTMS	SELECT SIGNAL VTIM PIN	0-3	0				0
59	CDMD	V CNT DWN MODE SWITCHING	0-3	0			1	
60	AFC	AFC LOOP GAIN SWITCHING	0-3	0			0	

NO.	ITEM	FUNCTION	DATA RANGE	INITIAL DATA				AVERAGE DATA
				NTSC	PAL-M	PAL-N	VIDEO	
61	FIFR	FIELD FREQUENCY	0-3	3*, 1**				
62	SBAL	SUB BALANCE	0-31	14				14
63	DISP	OSD POSITION	0-127	15				15
64	PADJ	POWER ADJUSTMENT	0-63	3				3
65	PSHP	PIP SUB SHARPNESS	0-15	7				7
66	PPIX	PIP SUB CONTRAST	0-15	7				7
67	PHUE	PIP SUB HUE	0-15	3				3
68	PCOL	PIP SUB COLOR	0-15	5	5	5	5	
69	PTRP	PIP C TRAP F0	0-15	7				7
70	PAFC	PIP AFC	0-3	1			1	
71	PYDR	PIP Y DRIVE	0-31	14				14
72	UPED	U PED	0-15	8				8
73	VPED	V PED	0-15	8				8
74	U2PE	U2 PED	0-15	5				5
75	V2PE	V2 PED	0-15	5				5
76	Y2DR	Y2 DRIVE	0-31	20				20
77	U2DR	U2 DRIVE	0-31	18				18
78	V2DRV	V2 DRIVE	0-31	9				9
79	PSFO	PIP SHP F0	0,1	1				1
80	PCD2	PIP CD MODE 2	0,1	1			1	
81	PDCT	PIP DC TRAN	0-7	4				4
82	PP/O	PIP PRE/OVER	0-3	1				1
83	PDLY	PIP Y DELAY	0-3	0				0
84	PBG	PIP BG	0-15	5				5
85	PEXT	PIP EXT COLOR	0,1	1*, 0**			1** 0*	
86	PHMK		0,1	0				0
87	ABL0		0,1	0				0
88	ABL1		0-7	1				1
89	PHPO	PIP HORIZONTAL POSITION	0-63	58				58
90	PVPO	PIP VERTICAL POSITION	0-31	18				18
91	PYSD	PIP YS DELAY	0-15	1				1
92	PYDL	PIP Y INPUT DELAY	0-7	0				0
93	PHVI	PIP HV SYNC	0,1	0				0
94	PCLP	PIP CLAMP	0-3	0				0
95	PCLK	PIP CLOCK	0,1	1				1
96	PIHS	INSET HORIZONTAL SYNC	0-15	2				2
97	PIVS	INSET VERTICAL SYNC	0-63	22				22
98	PMVS	MAIN VERTICAL SYN	0-63	17				17
99	PCON	PIP CONTRAST	0-15	10				10
100	PFRY	PIP FRAME Y	0-15	5				5
101	PFRC	PIP FRAME CHROMA	0-255	0				0
102	PFRW	PIP FRAME WIDTH	0-31	20				20
103	PSEL	PIP SEL	0,1	1				1
104	PPLL	PIP PLL	0-3	0				0
105	PVPE	PIP V PED	0-15	0				0
106	PUPE	PIP U PED	0-15	0				0

* NTSC MODELS

** TRINORMA MODELS

SERVICE ID0 25

Note: No. 1 through 106 show adjustment order.

(5) Feature ID Map

	KV-	DESTINATION	ID-0	ID-1	ID-2	ID-3	ID-4	ID-5	ID-6	ID-7
1	29AL40	(E)	145	3	173	195	63	1	0	64
2	29AL40A	(E)	151	3	173	195	55	1	0	64
3	29AL40C	(E)	145	3	173	195	63	1	0	64

5-2. A BOARD ADJUSTMENTS

H. FREQUENCY ADJUSTMENT

1. Input a monoscope signal.
2. Set to Service adjustment Mode.
3. Connect a frequency counter to base of Q501 (TP-500 H. DRIVE).
4. Select the item of AFC, set to 3 level (free run).
5. Check H. Frequency for the 15735 ± 200 Hz. (NTSC) or check H. Frequency for the 15650 ± 200 Hz. (Trinorma)
6. Select the item of AFC again, adjust the level "0".
7. Write into the memory by pressing **MUTING** then **ENTER**.

R ON ON (1)
 G ON OFF (0)
 B ON OFF (0)

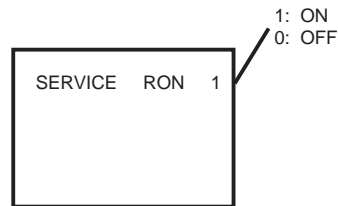

V. FREQUENCY ADJUSTMENT

1. Select video 1 with no signal input.
2. Set the conditions with standard setting.
3. Connect the frequency counter across TP-508 or CN501 VDY (+) pin ⑥ connector and ground.
4. Check V. Frequency for the 60 ± 2 Hz (NTSC)
5. Check V. Frequency for the 50 ± 2 Hz (Trinorma).

6. Connect an oscilloscope probe to C Board, CN301 Pin ⑤ (RED OUT).
7. Select RDRV with **1** and **4**.
8. Adjust with **3** and **6** for: 1.90 ± 0.05 Vp-p.

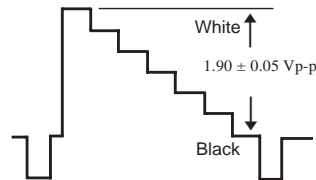

SUB CONTRACT ADJUSTMENT (SCON)

1. Input a color-bar signal.
2. Select the red color.
3. Set to Service adjustment Mode.
4. Select the item DCOL to "0" level.
5. Set the conditions as follows.

PICTURE MAX
 COLOR MIN
 BRIGHT CENTER

9. Reset the item DCOL to "1" level.
10. Write the memory by pressing **MUTING** then **ENTER**.
11. Return the following back to normal after adjustment.

PICTURE MAX
 COLOR CENTER
 BRIGHT CENTER
 R ON ON (1)
 G ON ON (1)
 B ON ON (1)

DISPLAY POSITION ADJUSTMENT (DISP)

1. Input a color-bar signal.
2. Set to Service adjustment Mode.
3. Select DISP with [1] and [4].
4. Adjust with [3] and [6] for adjustment of characters to center.
5. Write the memory by pressing [MUTING] then [ENTER].
6. Check if the text is displayed on the screen.

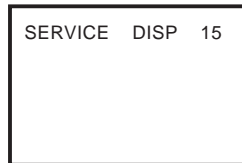
**SUB BRIGHT ADJUSTMENT (SBRT)**

1. Input a cross-hatch signal.
2. Set to Service adjustment Mode.
3. Set the PICTURE and BRIGHT to minimum.
4. Select SBRT with [1] and [4].
5. Adjust with [3] and [6] to obtain a faintly visible cross-hatch.
6. Write into the memory by pressing [MUTING] then [ENTER].

SUB HUE, SUB COLOR ADJUSTMENT (SHUE, SCOL)

1. Input a color-bar signal.
2. Set to Service adjustment Mode.
3. Select the item DCOL and set to "0" level.
4. Connect oscilloscope probe to C Board, CN301 Pin ⑦ (BLUE OUT).
5. Select SHUE and SCOL with [1] and [4].
6. Adjust with [3] and [6] for the $V1 = V4 \pm 0.1V_{p-p}$ (SCOL) and $V2 = V3 \pm 0.1V_{p-p}$ (SHUE).

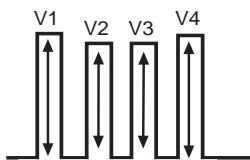

7. Reset the item DCOL to "1" level.
8. Write into the memory by pressing [MUTING] then [ENTER].

V. SIZE ADJUSTMENT (VSIZ)

1. Input a cross-hatch signal.
2. Set to Service adjustment mode.
3. Select VSIZ with [1] and [4].
4. Adjust with [3] and [6] for the best vertical size.

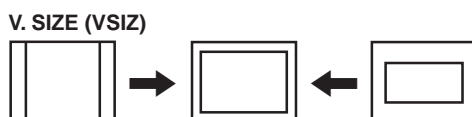
**V. CENTER ADJUSTMENT (VPOS)**

1. Input a cross-hatch signal.
2. Set to Service adjustment Mode.
3. Select VPOS with [1] and [4].
4. Adjust with [3] and [6] for the best vertical center.
5. Write into the memory by pressing [MUTING] then [ENTER].

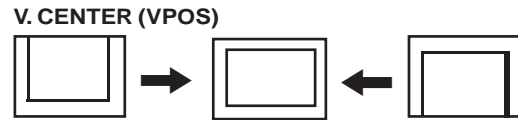
**H. CENTER ADJUSTMENT (HPOS)**

Note : Perform this adjustment after checking H. FREQUENCY.

1. Input a cross-hatch signal.
2. Set the Service adjustment Mode.
3. Select HPOS with [1] and [4].
4. Adjust with [3] and [6] for the best horizontal center.
5. Write into the memory by pressing [MUTING] then [ENTER].

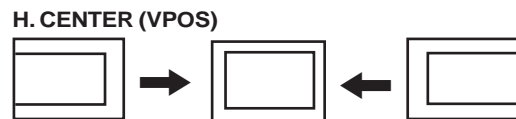
**V. LINEARITY (VLIN) AND V CORRECTION**

1. Input a cross-hatch signal.
2. V. Correction is automatically adjusted from the circuit and should satisfy the conditions below:

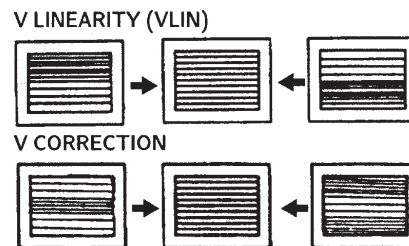
**SERVICE ADJUSTMENT MODE MEMORY**

1. Change DCOL to "1".
2. After completing all adjustments, press "0" then [ENTER].

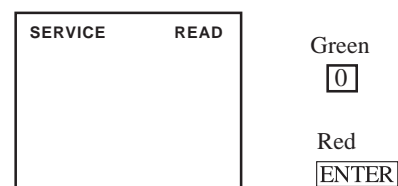
READ FROM MEMORY

6-2. Circuit Boards Location

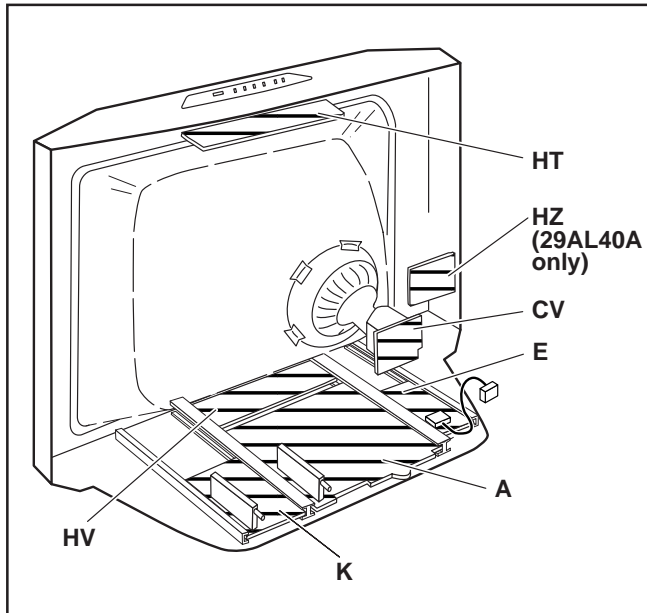

6-3. Printed Wiring Boards and Schematic Diagrams

Note:

- All capacitors are in μF unless otherwise noted. pF : $\mu\mu\text{F}$ 50WV or less are not indicated except for electrolytic and tantalums.
- All electrolytics are 50V unless otherwise specified
- Indication of resistance, which does not have one for rating electrical power, is as follows:

Pitch: 5mm
Rating electrical power 1/4W

- All resistors are in ohms.
 $\text{K}\Omega=1000\Omega$, $\text{M}\Omega=1000\text{K}\Omega$
- nonflammable resistor.
- Δ : internal component.
- : panel designation and adjustment for repair.
- All variable and adjustable resistors have characteristic curve B, unless otherwise noted.
- The components identified by in this manual have been carefully factory-selected for each set in order to satisfy regulations regarding X-ray radiation. Should replacement be required, replace only with the value originally used.
- When replacing components identified by make the necessary adjustments indicated. If results do not meet the specified value, change the component identified by and repeat the adjustment until the specified value is achieved. (Refer to R584 on page 17 and 18).

- When replacing parts in the table below be sure to perform the related adjustment.

Part replaced (■)	Adjustment (⊠)
DY, C511, C572, C573, C574, C575, D573, D574, R582, R583, R585, R586, R578, R579, T504, IC301, IC521, IC603, C507, C508, C509, C515, C520, L591, L501	HV HOLD-DOWN (R584)

IC603, IC601, R699	B+ VOLTAGE CONFIRMATION
--------------------	-------------------------

- All voltages are in V.
- Voltage is DC with respect to ground unless otherwise noted.
- Readings are taken with a $10\text{M}\Omega$ digital multimeter.
- Readings are taken with a color-bar signal input.
- Voltage variations may be noted due to normal production tolerance.
- Circled numbers are waveform references.

- : B + Line
- : B - Line
- : signal path

Reference Information

RESISTOR	: RN	METAL FILM
	: RC	SOLID
	: FPRD	NON FLAMMABLE CARBON
	: FUSE	NON FLAMMABLE FUSIBLE
	: RW	NON FLAMMABLE WIREWOUND
	: RS	NON FLAMMABLE METAL OXIDE
	: RB	NON FLAMMABLE CEMENT
	: ⌘	ADJUSTMENT RESISTOR
COIL	: LF-8L	MICRO INDUCTOR
CAPACITOR	: TA	TANTALUM
	: PS	STYROL
	: PP	POLYPROPYLENE
	: PT	MYLAR
	: MPS	METALIZED POLYESTER
	: MPP	METALIZED POLYPROPYLENE
	: ALB	BIPOLAR
	: ALT	HIGH TEMPERATURE
	: ALR	HIGH RIPPLE

Note: The symbol display is on the component side.

The components identified by shading and mark Δ are critical for safety. Replace only with part number specified.

The symbol indicates fast operating fuse. Replace only with fuse of same rating as marked.

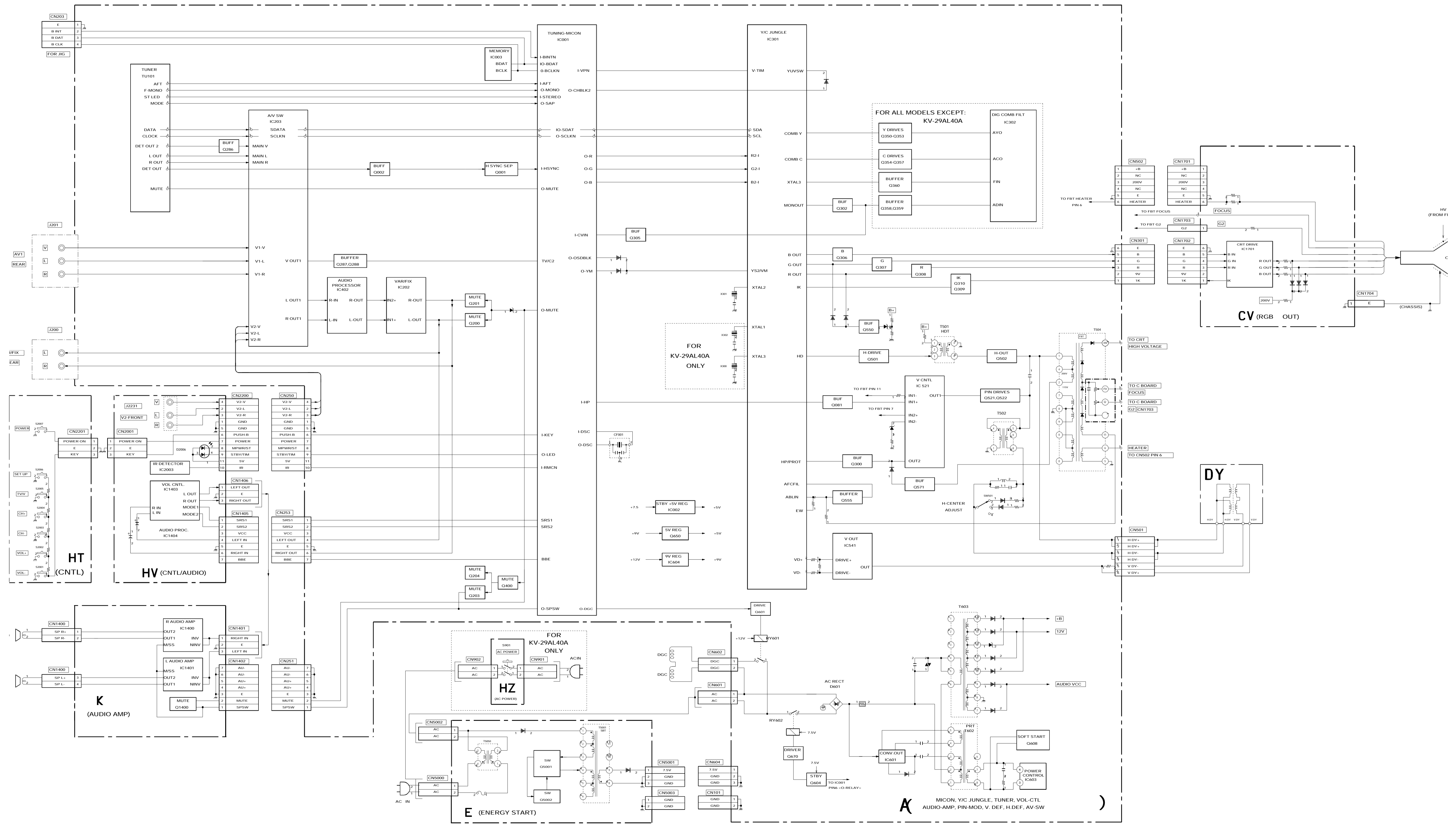

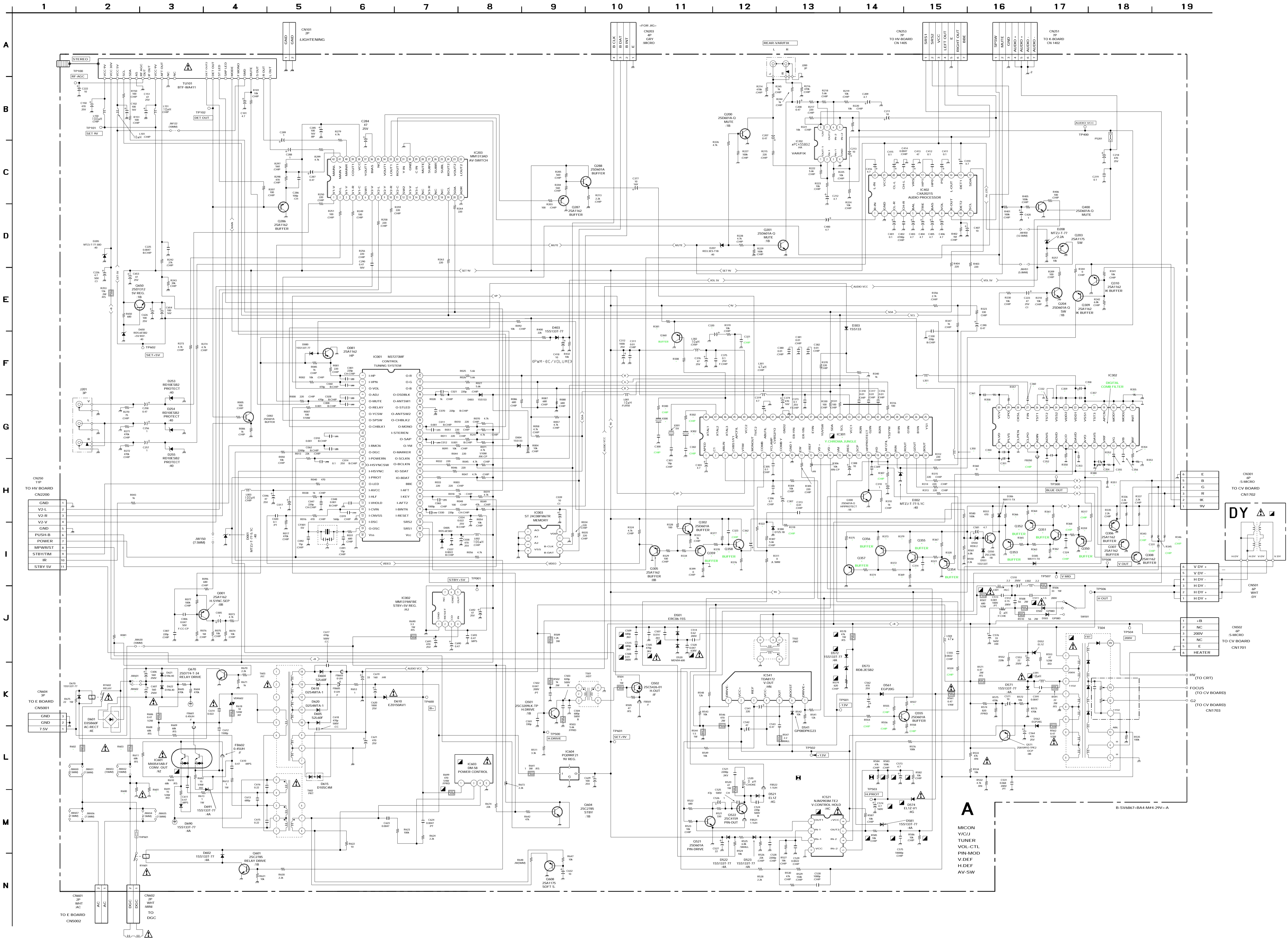

TO HV BOARD
CN200

1	GND
2	V2-L
3	V2-R
4	V2-V
5	GND
6	PUSH.B
7	POWER
8	MPWRST
9	STBYTM
10	IR
11	STBY SV

TO E BOARD
CN501

1	GND
2	GND
3	GND
4	7.5V

TO E BOARD
CN502

1	DCG
2	DCG
3	DCG
4	DCG
5	DCG
6	DCG
7	DCG
8	DCG
9	DCG
10	DCG
11	DCG
12	DCG
13	DCG
14	DCG
15	DCG
16	DCG
17	DCG
18	DCG
19	DCG

TO CV BOARD
CN170

1	6 V DY +
2	5 V DY -
3	4 V DY -
4	3 V DY -
5	2 V DY -
6	1 V DY +

TO CV BOARD
CN171

1	+B
2	NC
3	200V
4	NC
5	NC
6	HEATER

TO CV BOARD
CN172

1	FOCUS (TO CV BOARD)
2	G2 (TO CV BOARD)

TO CV BOARD
CN173

1	1
2	2
3	3
4	4
5	5
6	6
7	7
8	8
9	9
10	10
11	11
12	12
13	13
14	14
15	15
16	16
17	17
18	18
19	19

A
MICON
VIC/J
TUNER
VOL-CTL
PIN-MOD
V-DEF
H-DEF
AV-SW

B-SV6867-BA4-MH4-2W-A

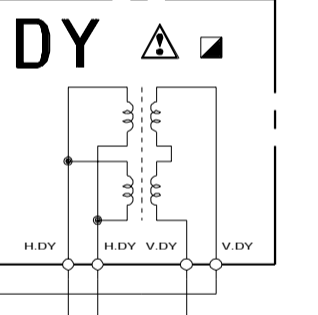

• A BOARD WAVEFORMS

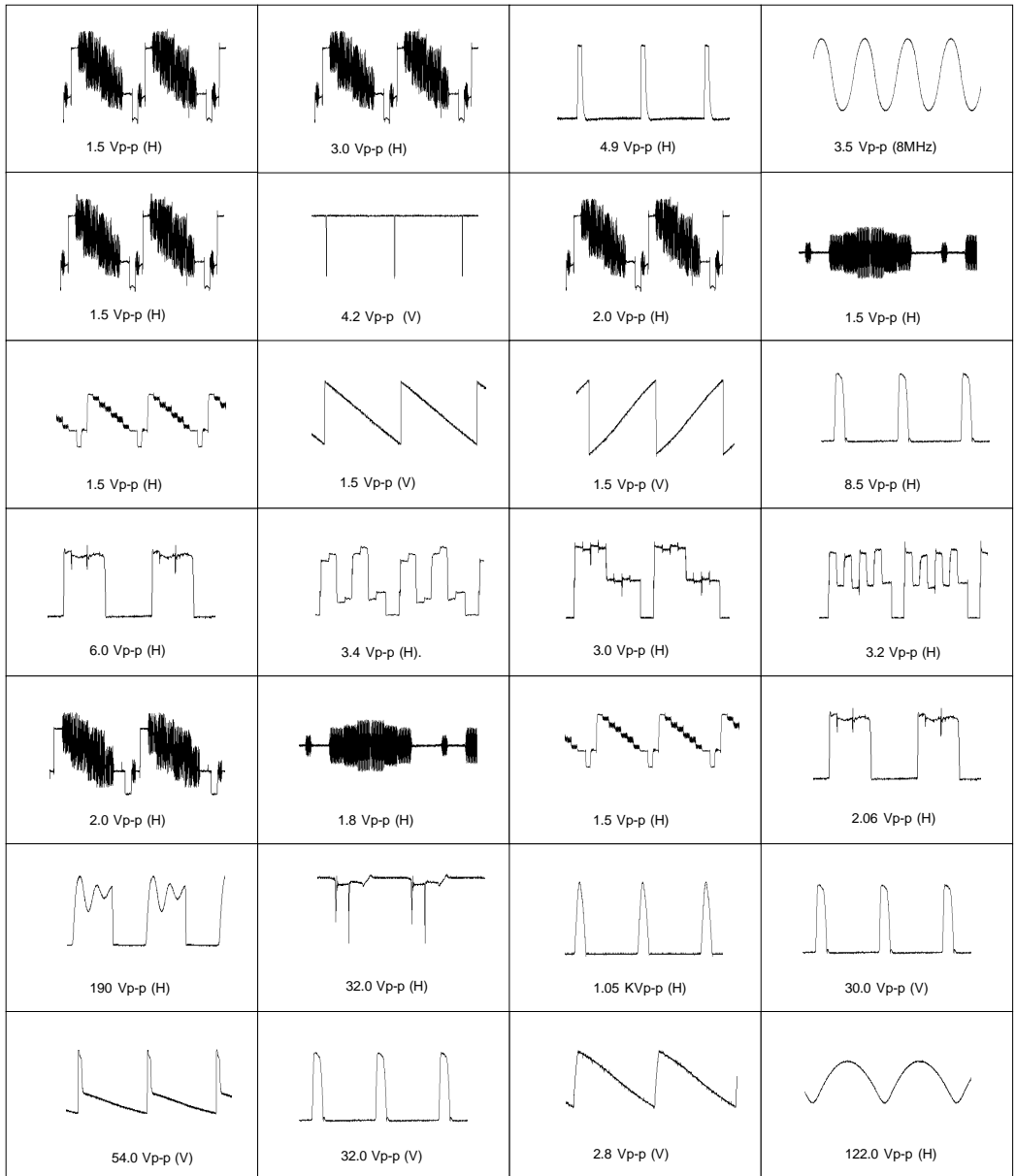

1

2

3

4

5

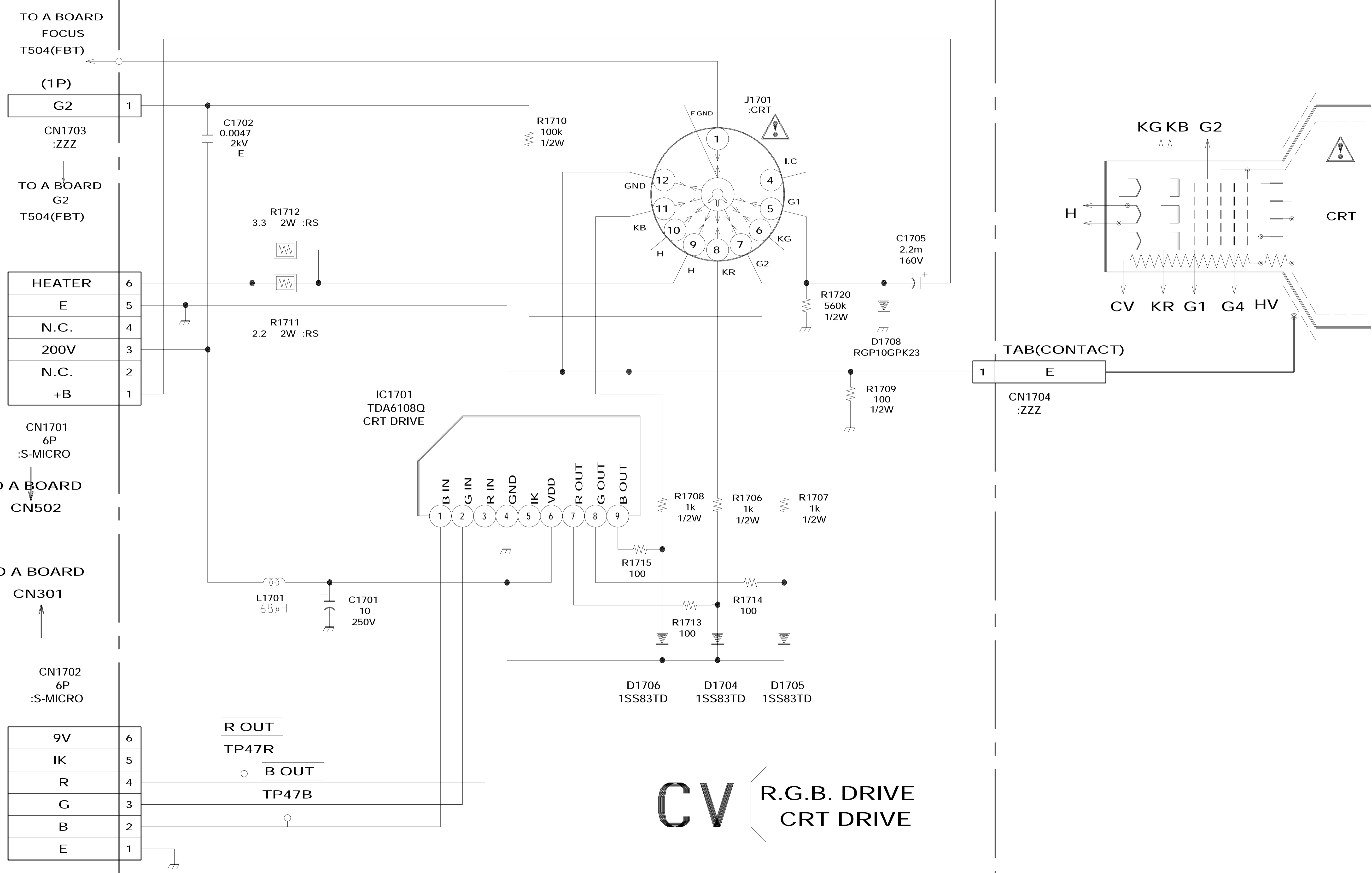

TO A BOARD
FOCUS
T504(FBT)

(1P)	
G2	1

CN1703
:ZZZ

TO A BOARD
G2
T504(FBT)

HEATER	6
E	5
N.C.	4
200V	3
N.C.	2
+B	1

180V
CN1701
6P
:S-MICRO

TO A BOARD
CN502

TO A BOARD
CN301

CN1702
6P
:S-MICRO

9V	6
IK	5
R	4
G	3
B	2
E	1

R OUT
TP47R

B OUT
TP47B

CV R.G.B. DRIVE
CRT DRIVE

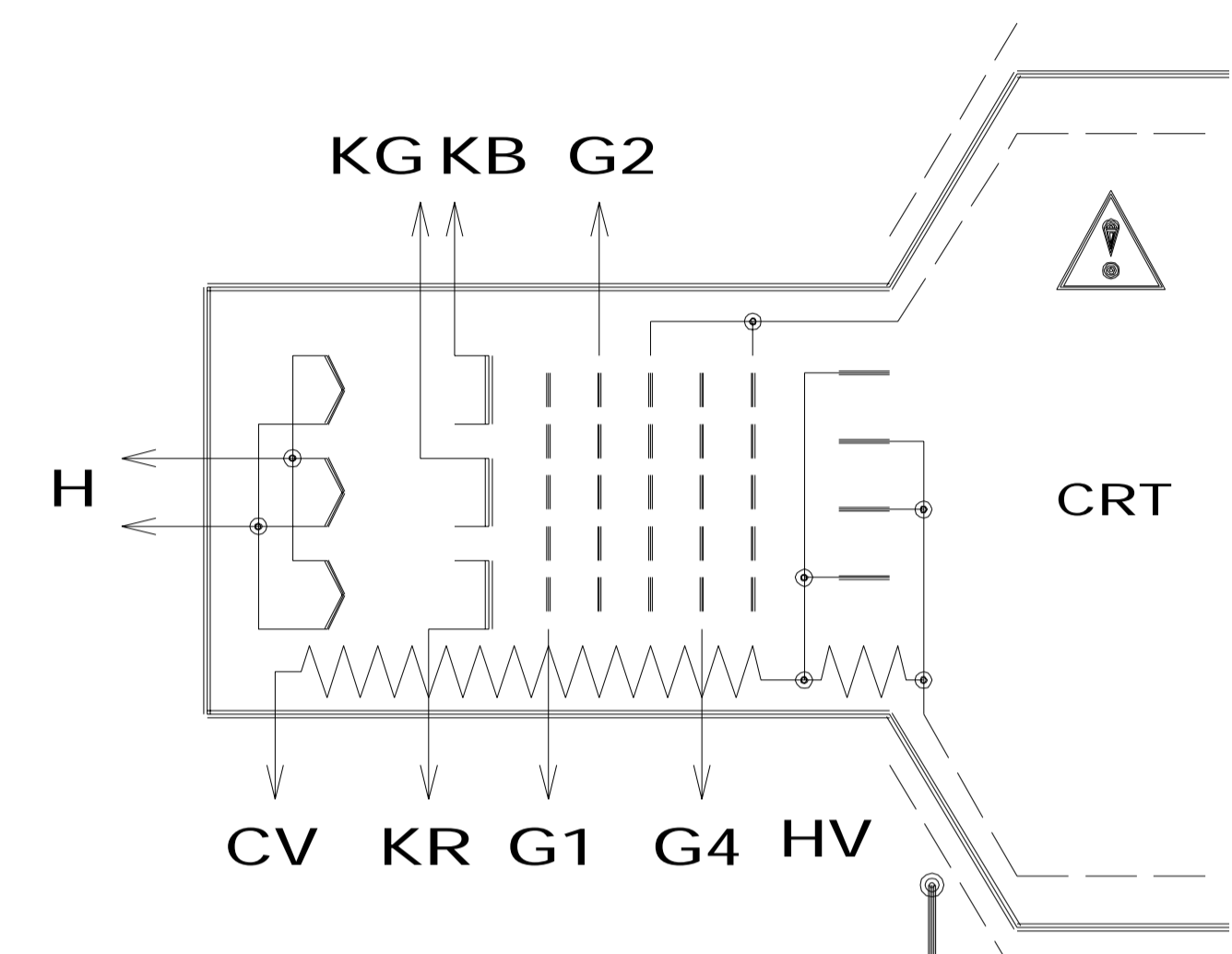

TAB(CONTACT)	
1	E

CN1704
:ZZZ

CV BOARD WAVEFORMS

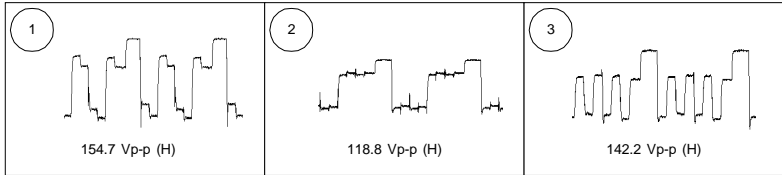

1

2

3

4

5

TO A BOARD
CN601

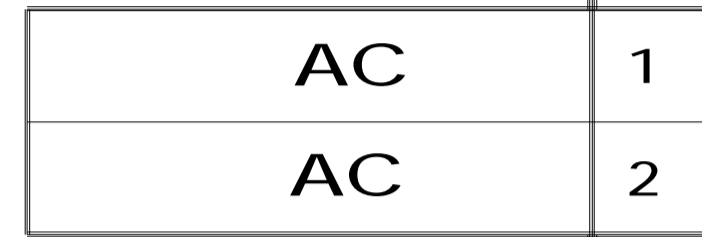

CN5002
2P
:PIN-Z

D5001
ERC04-06S

D5002
ERC04-06S

C5000
22
250V

C5002
22
250V

R5001
4.7
:FPRD

C5003
0.01
630V



T5001
SBT

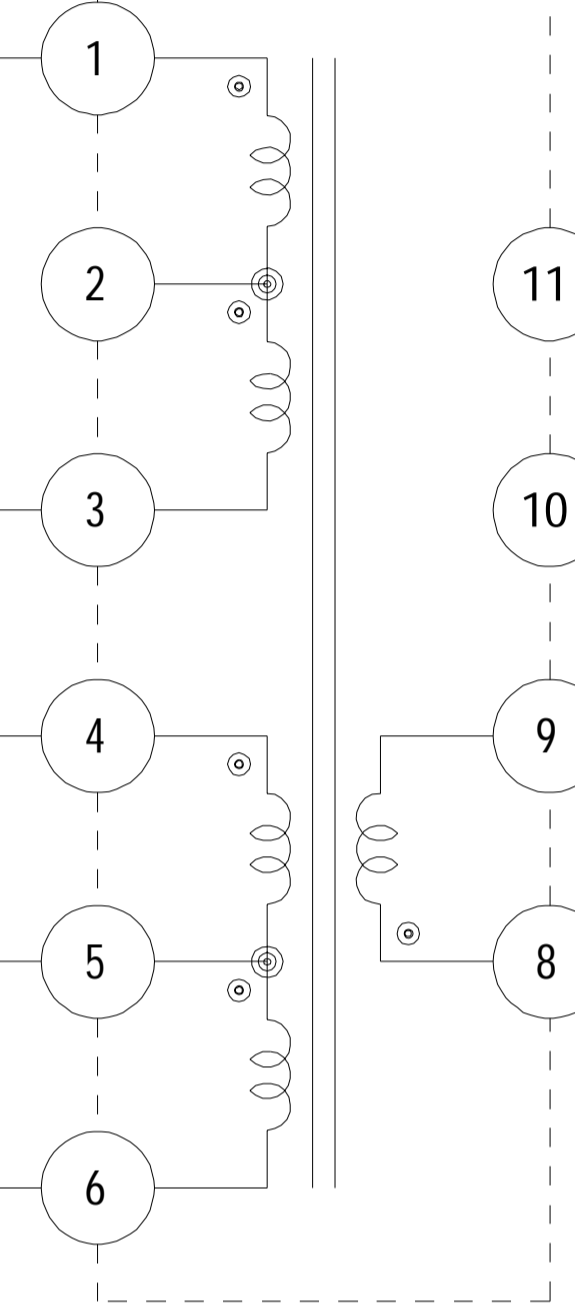

D5003
ERA22-08TP3

R5002
470k

11

10

D5008
D1NL20-TA

TO A BOARD
CN604

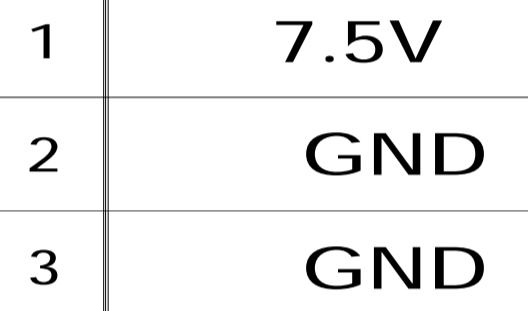

CN5001
3P
WHT
:S-MICRO

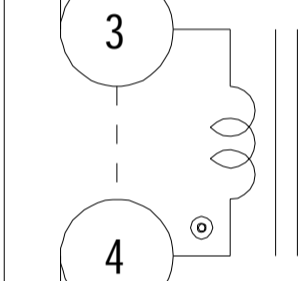

C5050
0.47
125V

R5050
2.2M

VDR5050

F5050

TO AC
CONNECTOR

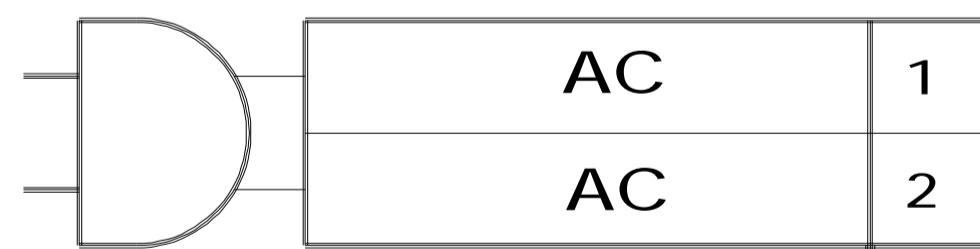

CN5000
2P
:PINZ

Q5001
2SK2845
SW

R5003
22M

C5004
0.001

R5007
2.2k

D5005
1SS133-T-77

R5013
680

D5004
1SS133-T-77

R5008
10k

R5009
47k

C5006
0.001

C5021
JW
(7.5MM)

C5020
0.0047
125V

D5006
MTZJ-T-77-6.2C

D5007
D1N20R-TA

R5010
680

C5008
0.001

R5012
1k

C5009
22

C5007
470p

R5010
680

Q5002
2SC3311A
SW

R5011
6.8
1/2W
:FPRD

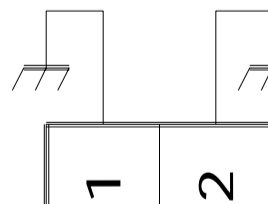

CN5003
2P

:LIGHTNING
TO A BOARD

E (ENERGY START)

B-SV6867<BA4-M#4-29V>-E

1 2 3 4 5 6

A
B
C
D
E
F

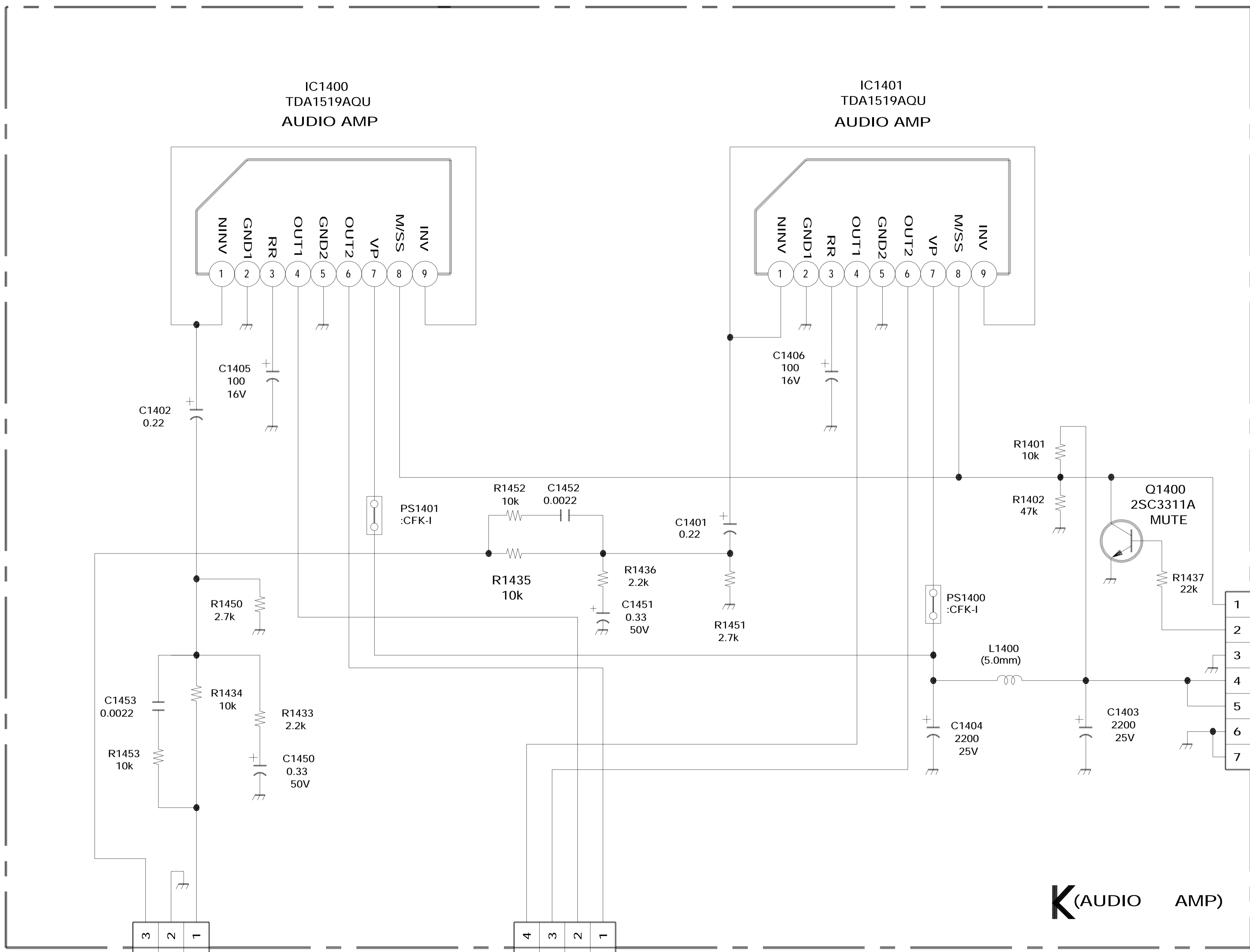

CN1402
7P

1	SPSW
2	MUTE
3	E
4	AU+
5	AU+
6	AU-
7	AU-

TO A BOARD
CN251

K (AUDIO AMP)

B-SV6867<BA4-M#4-29V>- K

CN1401
3P
WHT
:S-MICRO

LEFT IN
3
2
1
E
RIGHT IN

TO HV BOARD
CN1406

CN1400
4P
WTH
:S-MICRO

TO SPEAKERS

SPL-
4
SPL+
3
SPR-
2
SPR+
1

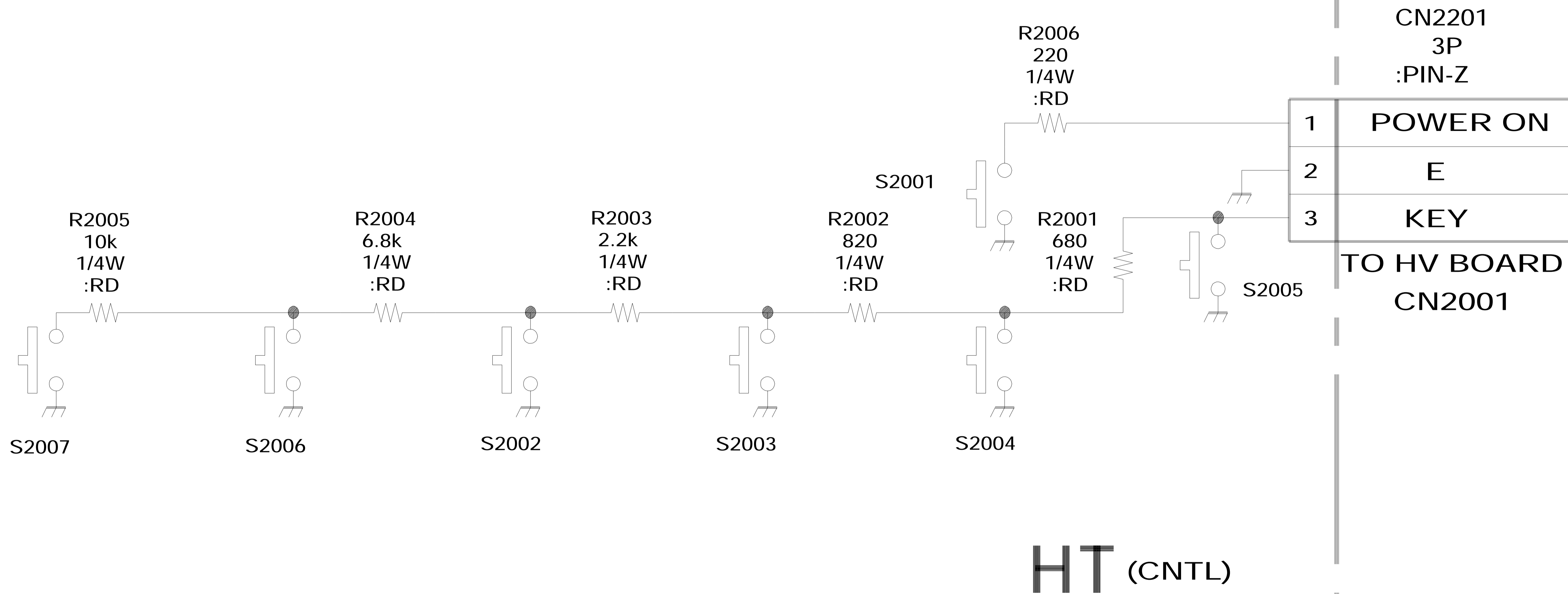

B-SV6867<BA4-M#4-29V>-HT

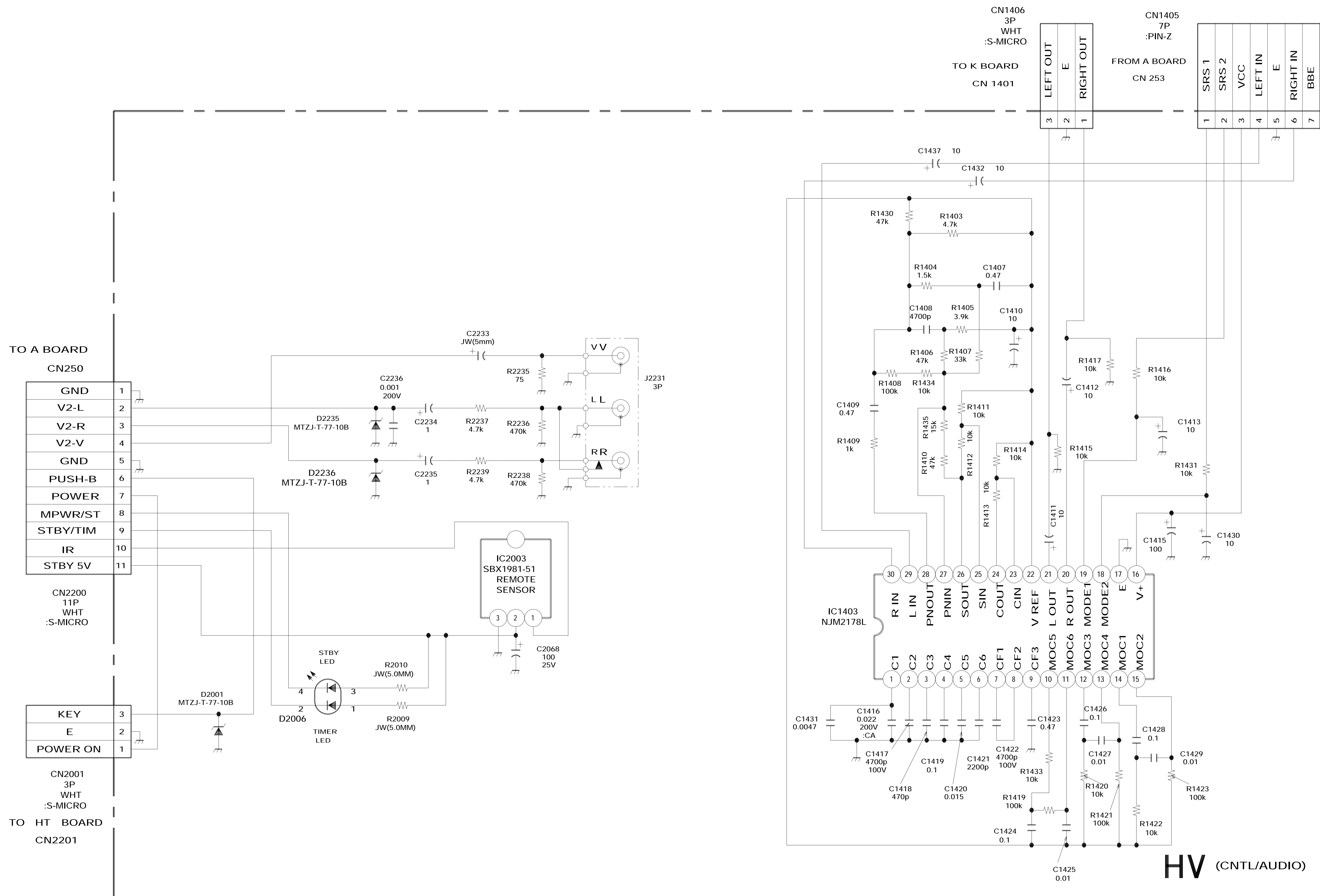

HV (CNTL/AUDIO)

6-4. SEMICONDUCTORS

2SA1162-G
2SD601A-Q

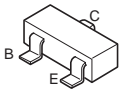

2SA1175-HFE
2SC2785-HFE
2SA933AS-QRT

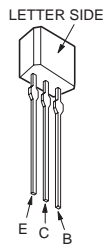

2SC3209LK
2SD1312-K
2SD774-34



2SC4159-E

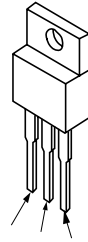

2SA1091-0

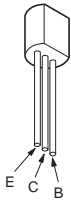

2SK2845-LB102

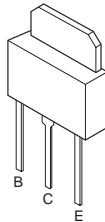

2SC5426-01



RD9.1EW



MA111

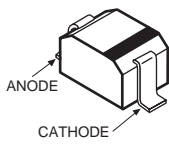

MX0541B-F

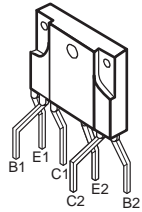

D3SB60F
D1NL40-TA2

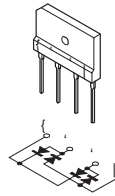

D10SC4M

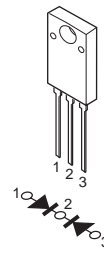

D1NL20R
ERA22-08TP3
RD6.2ESB2
RD8.2ESB2
MTZJ-3.3
MTZJ-5.1C
RD5.6ESB2

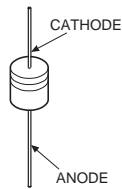

D2S4MF
MTZJ-T-77-5.1C
MTZJ-T-77-30D
D1NL20-TA
EGP20G
EL1Z
1SS83
1S133T-77

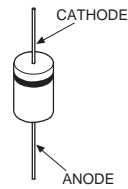

S2L60F
GP08D
U05G

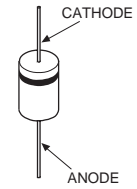

SECTION 7 EXPLODED VIEWS

Note:

The components identified by shading and mark \triangle are critical for safety. Replace only with part number specified.

Note:

Les composants identifiés par un triangle et une marque \triangle sont critiques pour la sécurité. Ne les remplacer que par une pièce portant le numéro spécifié.

- Items marked " * " are not stocked since they are seldom required for routine service. Some delay should be anticipated when ordering these items.

- All variable and adjustable resistors have characteristic curve B, unless otherwise noted.

RESISTORS

- All resistors are in ohms
- F : nonflammable

CAPACITORS

- MF = μ F

INDUCTORS

- UH = μ H, MMH = mH

When indicating parts by reference number, please include the board name.

7-1. CHASSIS

- 7-685-663-79 SCREW +BVTP 4X16
- ▲ 7-685-648-79 SCREW +BVTP 3X12

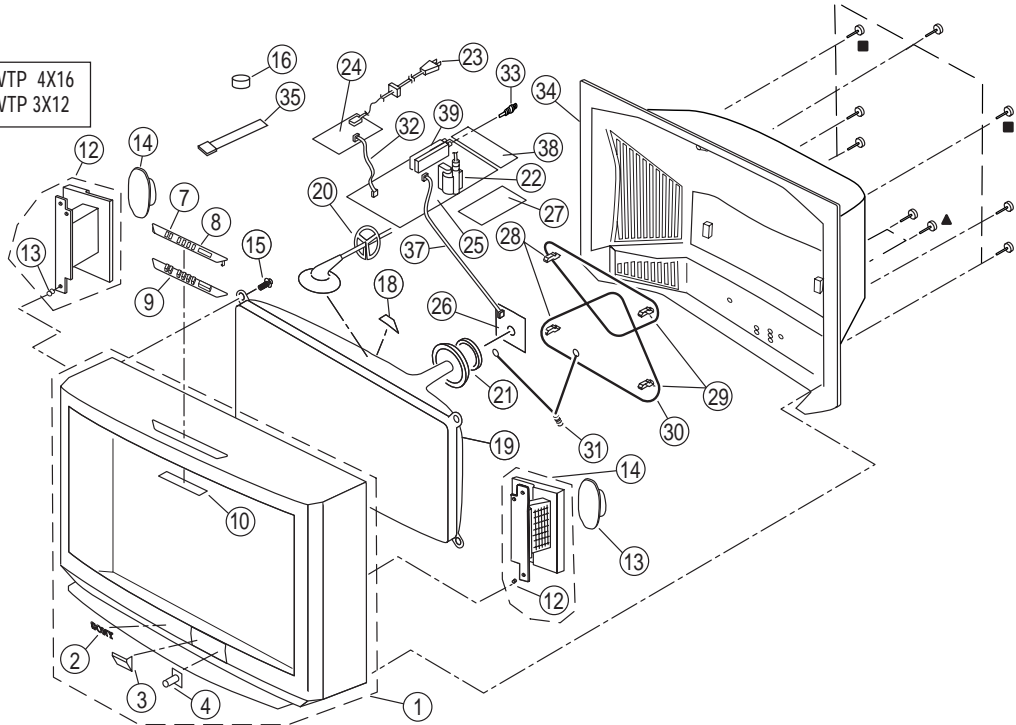

REF.NO.	PART NO.	DESCRIPTION	REMARK
1	X-4035-965-1	BEZNET ASSY (KV-29AL40/C)	2-4
1	X-4035-963-1	BEZNET ASSY (KV-29AL40A)	2-4
2	4-046-160-01	EMBLEM (NO.9), SONY	
3	4-064-768-01	DOOR	
4	4-064-767-01	GUIDE, LED	
7	4-064-764-01	BRACKET, TOP CONTROL	
8	4-064-763-01	PANEL, TOP CONTROL	
9	4-064-765-01	BUTTON, TOP CONTROL	
10 *	A-1372-482-A	HT BOARD, MOUNTED	
12	X-4035-964-1	BAFFLE ASSY, SPEAKER	13
13	4-374-745-31	CUSHION (A)	
14	1-505-993-11	SPEAKER (8X13CM)	
15	4-041-268-01	SCREW (7), TAPPING	
16	1-452-032-00	MAGNET, DISC	
18	4-053-005-01	SPACER, DY	
19 \triangle	8-733-873-05	CRT 29NX (KV-29AL40)	
19 \triangle	8-733-874-05	CRT 29NX (KV-29AL40A/40C)	
20	3-704-372-31	HOLDER, HV CABLE	
21 \triangle	8-451-486-21	DY Y29NXA-V2	
22 \triangle	1-453-268-11	TRANSFORMER, FBT ASSY NX4005//X4J4	

REF.NO.	PART NO.	DESCRIPTION	REMARK
23 \triangle	1-751-057-21	CORD, POWER (w/CONNECTOR) 10A/125V (KV-29AL40)	
23 \triangle	1-783-838-31	CORD, POWER (w/CONNECTOR) (KV-29AL40A)	
23 \triangle	1-769-796-71	CORD, POWER (w/CONNECTOR) (KV-29AL40C)	
24 *	A-1343-525-A	E BOARD (VAR), MOUNTED (KV-29AL40)	
24 *	A-1343-526-A	E BOARD (VAR), MOUNTED (KV-29AL40A/40C)	
25 *	A-1298-609-A	A BOARD, COMPLETE (KV-29AL40)	
25 *	A-1298-672-A	A BOARD, COMPLETE (KV-29AL40A)	
25 *	A-1298-610-A	A BOARD, COMPLETE (KV-29AL40C)	
26 *	A-1331-776-A	CV BOARD (COM), MOUNTED	
27 *	A-1380-582-A	K BOARD (VAR), MOUNTED	
28	4-040-387-01	HOLDER (M), DGC	
29	4-040-388-01	HOLDER (S), DGC	
30 \triangle	1-416-588-11	COIL DEMAGNETIC (KV-29AL40)	
30 \triangle	1-416-589-21	COIL DEMAGNETIC (KV-29AL40A/40C)	
31	4-036-329-01	SPRING (B), TENSION	
32	1-900-802-13	CONNECTOR ASSY, 4P	
33	1-766-374-11	PLUG, F-PIN	
34	4-064-762-01	COVER, REAR	
35	4-062-047-01	PIECE A (110), CONV CORRECT	
37 *	1-900-802-39	CONNECTOR ASSY, 6 PIN	
38 *	A-1372-483-A	HV BOARD (VAR), MOUNTED	
39 \triangle	8-598-431-00	TUNER, FSS BTF-WA411	

The components identified with gray shading and a critical symbol (△) are critical for safety. Replace only with part number specified.

Les composants identifiés par un triangle et une marque △ sont critiques pour la sécurité. Ne les remplacer que par une pièce portant le numéro spécifié.

7-2. MAIN POWER SWITCH (KV-29AL40A)

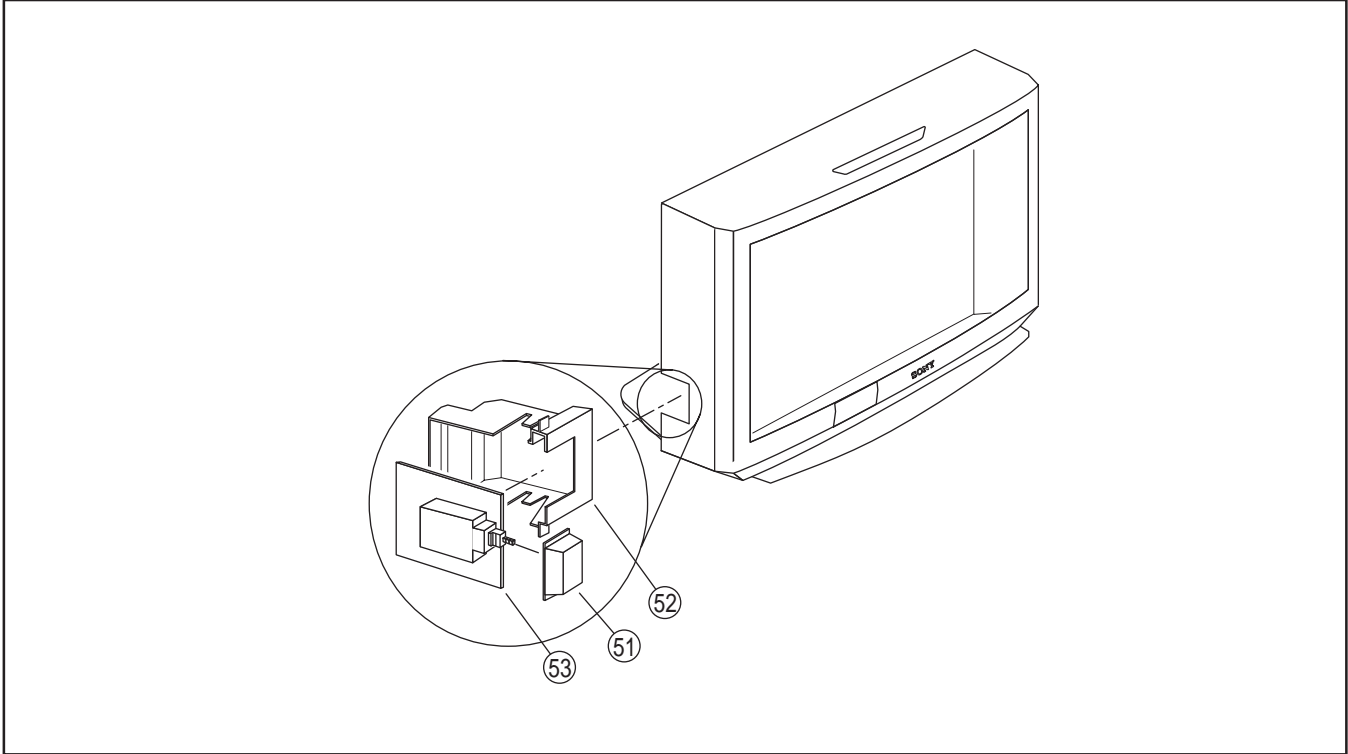

<u>REF.NO.</u>	<u>PART NO.</u>	<u>DESCRIPTION</u>	<u>REMARK</u>
51	4-062-611-01	BUTTON, MAIN POWER	
52 *	4-062-612-01	BRACKET, MAIN POWER	
53 *	A-1372-117-A	HZ BOARD, MOUNTED	

SECTION 8 ELECTRICAL PARTS LIST

**Note:**

The components identified by shading and mark **A** are critical for safety. Replace only with part number specified.

- Items marked " * " are not stocked since they are seldom required for routine service. Some delay should be anticipated when ordering these items.

RESISTORS

- All resistors are in ohms
- F : nonflammable

CAPACITORS

- MF = μF

INDUCTORS

- UH = μH , MMH = mH

When indicating parts by reference number, please include the board name.

Note:

Les composants identifiés par un trame et une marque **A** sont critiques pour la sécurité. Ne les remplacer que par une pièce portant le numéro spécifié.

- All variable and adjustable resistors have characteristic curve B, unless otherwise noted.

REF.NO.	PART NO.	DESCRIPTION	REMARK			REF.NO.	PART NO.	DESCRIPTION	REMARK		
A											
*	A-1298-609-A	A BOARD, COMPLETE (KV-29AL40)				C207	1-126-959-11	ELECT	0.47MF	20%	50V
*	A-1298-672-A	A BOARD, COMPLETE (KV-29AL40A)				C208	1-126-959-11	ELECT	0.47MF	20%	50V
*	A-1298-610-A	A BOARD, COMPLETE (KV-29AL40C)				C209	1-126-963-11	ELECT	4.7MF	20%	50V
	4-382-854-01	SCREW (M3X8), P, SW (+)				C211	1-126-964-11	ELECT	10MF	20%	50V
	4-382-854-11	SCREW (M3X10), P, SW (+)				C212	1-126-963-11	ELECT	4.7MF	20%	50V
	<u>CAPACITOR</u>										
						C213	1-126-964-11	ELECT	10MF	20%	50V
C001	1-163-259-91	CERAMIC CHIP	220PF	5%	50V	C218	1-126-941-11	ELECT	470MF	20%	25V
C005	1-126-960-11	ELECT	1MF	20%	50V	C219	1-130-495-00	FILM	0.1MF	5%	50V
C007	1-163-259-91	CERAMIC CHIP	220PF	5%	50V	C222	1-126-964-11	ELECT	10MF	20%	50V
C008	1-163-009-11	CERAMIC CHIP	0.001MF	10%	50V	C223	1-104-664-11	ELECT	47MF	20%	25V
C010	1-163-009-11	CERAMIC CHIP	0.001MF	10%	50V	C225	1-163-017-00	CERAMIC CHIP	0.0047MF	10%	50V
C011	1-163-009-11	CERAMIC CHIP	0.001MF	10%	50V	C226	1-126-963-11	ELECT	4.7MF	20%	50V
C012	1-163-009-11	CERAMIC CHIP	0.001MF	10%	50V	C256	1-126-960-11	ELECT	1MF	20%	50V
C014	1-164-004-11	CERAMIC CHIP	0.1MF	10%	25V	C257	1-126-960-11	ELECT	1MF	20%	50V
C017	1-126-960-11	ELECT	1MF	20%	50V	C258	1-126-959-11	ELECT	0.47MF	20%	50V
C019	1-163-135-00	CERAMIC CHIP	560PF	5%	50V	C284	1-104-664-11	ELECT	47MF	20%	25V
C020	1-130-495-00	FILM	0.1MF	5%	50V	C285	1-126-235-11	ELECT	100MF	20%	16V
C021	1-163-259-91	CERAMIC CHIP	220PF	5%	50V	C286	1-163-251-11	CERAMIC CHIP	100PF	5%	50V
C028	1-163-005-11	CERAMIC CHIP	470PF	10%	50V	C287	1-126-959-11	ELECT	0.47MF	20%	50V
C034	1-163-037-11	CERAMIC CHIP	0.022MF	10%	50V	C288	1-126-960-11	ELECT	1MF	20%	50V
C037	1-164-161-11	CERAMIC CHIP	0.0022MF	10%	50V	C289	1-126-960-11	ELECT	1MF	20%	50V
C038	1-126-941-11	ELECT	470MF	20%	25V	C290	1-164-005-11	CERAMIC CHIP	0.47MF		25V
C039	1-126-964-11	ELECT	10MF	20%	50V	C300	1-163-233-11	CERAMIC CHIP	18PF	5%	50V
C046	1-104-664-11	ELECT	47MF	20%	25V						(KV-29AL40A)
C047	1-163-259-91	CERAMIC CHIP	220PF	5%	50V	C301	1-163-099-00	CERAMIC CHIP	18PF	5%	50V
C048	1-163-009-11	CERAMIC CHIP	0.001MF	10%	50V	C302	1-163-233-11	CERAMIC CHIP	18PF	5%	50V
C060	1-163-005-11	CERAMIC CHIP	470PF	10%	50V						(KV-29AL40A)
C062	1-164-161-11	CERAMIC CHIP	0.0022MF	10%	50V	C303	1-126-963-11	ELECT	4.7MF	20%	50V
C065	1-163-009-11	CERAMIC CHIP	0.001MF	10%	50V	C305	1-164-004-11	CERAMIC CHIP	0.1MF	10%	25V
C070	1-163-259-91	CERAMIC CHIP	220PF	5%	50V	C306	1-164-004-11	CERAMIC CHIP	0.1MF	10%	25V
C091	1-163-231-11	CERAMIC CHIP	15PF	5%	50V	C307	1-126-964-11	ELECT	10MF	20%	50V
C092	1-163-231-11	CERAMIC CHIP	15PF	5%	50V						(KV-29AL40/KV-29AL40C)
C101	1-126-963-11	ELECT	4.7MF	20%	50V	C308	1-126-964-11	ELECT	10MF	20%	50V
C102	1-126-382-11	ELECT	100MF	20%	16V	C309	1-163-021-91	CERAMIC CHIP	0.01MF	10%	50V
C150	1-126-941-11	ELECT	470MF	20%	25V						(KV-29AL40/KV-29AL40C)
C151	1-104-664-11	ELECT	47MF	20%	25V	C309	1-163-017-00	CERAMIC CHIP	0.0047MF	10%	50V
											(KV-29AL40A)
						C310	1-126-960-11	ELECT	1MF	20%	50V
						C311	1-163-021-91	CERAMIC CHIP	0.01MF	10%	50V
						C312	1-126-942-61	ELECT	1000MF	20%	25V
						C313	1-163-021-91	CERAMIC CHIP	0.01MF	10%	50V



Note:

The components identified with shading and a critical symbol \triangle are critical for safety. Replace only with part number specified.

Note:

Les composants identifiés par un trame et une marque \triangle sont critiques pour la sécurité. Ne les remplacer que par une pièce portant le numéro spécifié.

REF.NO.	PART NO.	DESCRIPTION	REMARK	REF.NO.	PART NO.	DESCRIPTION	REMARK
C314	1-163-003-11	CERAMIC CHIP	330PF 10% 50V (KV-29AL40/KV-29AL40C)	C375	1-163-038-91	CERAMIC CHIP	0.1MF 25V
C316	1-163-021-91	CERAMIC CHIP	0.01MF 10% 50V	C376	1-104-664-11	ELECT	47MF 20% 25V
C317	1-163-021-91	CERAMIC CHIP	0.01MF 10% 50V	C377	1-126-964-11	ELECT	10MF 20% 50V
C318	1-163-021-91	CERAMIC CHIP	0.01MF 10% 50V	C380	1-163-021-91	CERAMIC CHIP	0.01MF 10% 50V
C319	1-126-963-11	ELECT	4.7MF 20% 50V	C381	1-163-021-91	CERAMIC CHIP	0.01MF 10% 50V
C320	1-126-959-11	ELECT	0.47MF 20% 50V (KV-29AL40/KV-29AL40C)	C382	1-163-021-91	CERAMIC CHIP	0.01MF 10% 50V
C320	1-126-957-11	ELECT	0.22MF 20% 50V (KV-29AL40A)	C390	1-126-959-11	ELECT	0.47MF 20% 50V
C321	1-163-133-00	CERAMIC CHIP	470PF 5% 50V (KV-29AL40/KV-29AL40C)	C400	1-126-963-11	ELECT	4.7MF 20% 50V
C321	1-163-259-91	CERAMIC CHIP	220PF 5% 50V (KV-29AL40A)	C401	1-126-956-91	ELECT	0.1MF 20% 50V
C323	1-163-243-11	CERAMIC CHIP	47PF 5% 50V (KV-29AL40/KV-29AL40C)	C402	1-163-017-00	CERAMIC CHIP	0.0047MF 10% 50V
C324	1-163-251-11	CERAMIC CHIP	100PF 5% 50V (KV-29AL40/KV-29AL40C)	C403	1-126-963-11	ELECT	4.7MF 20% 50V
C330	1-163-003-11	CERAMIC CHIP	330PF 10% 50V	C404	1-126-963-11	ELECT	4.7MF 20% 50V
C331	1-163-005-11	CERAMIC CHIP	470PF 10% 50V (KV-29AL40/KV-29AL40C)	C405	1-126-963-11	ELECT	4.7MF 20% 50V
C332	1-163-009-11	CERAMIC CHIP	0.001MF 10% 50V (KV-29AL40/KV-29AL40C)	C406	1-126-963-11	ELECT	4.7MF 20% 50V
C350	1-163-021-91	CERAMIC CHIP	0.01MF 10% 50V (KV-29AL40/KV-29AL40C)	C407	1-126-964-11	ELECT	10MF 20% 50V
C351	1-126-964-11	ELECT	10MF 20% 50V (KV-29AL40/KV-29AL40C)	C410	1-126-963-11	ELECT	4.7MF 20% 50V
C352	1-163-021-91	CERAMIC CHIP	0.01MF 10% 50V (KV-29AL40/KV-29AL40C)	C411	1-126-956-91	ELECT	0.1MF 20% 50V
C353	1-163-038-91	CERAMIC CHIP	0.1MF 25V (KV-29AL40/KV-29AL40C)	C412	1-130-495-00	FILM	0.1MF 5% 50V
C354	1-163-038-91	CERAMIC CHIP	0.1MF 25V (KV-29AL40/KV-29AL40C)	C413	1-126-967-11	ELECT	47MF 20% 50V
C355	1-164-222-11	CERAMIC CHIP	0.22MF 25V (KV-29AL40/KV-29AL40C)	C414	1-163-017-00	CERAMIC CHIP	0.0047MF 10% 50V
C356	1-163-038-91	CERAMIC CHIP	0.1MF 25V (KV-29AL40/KV-29AL40C)	C415	1-126-956-91	ELECT	0.1MF 20% 50V
C357	1-163-021-91	CERAMIC CHIP	0.01MF 10% 50V (KV-29AL40/KV-29AL40C)	C416	1-126-963-11	ELECT	4.7MF 20% 50V
C358	1-104-664-11	ELECT	47MF 20% 25V (KV-29AL40/KV-29AL40C)	C418	1-126-964-11	ELECT	10MF 20% 50V
C359	1-163-021-91	CERAMIC CHIP	0.01MF 10% 50V (KV-29AL40/KV-29AL40C)	C420	1-126-960-11	ELECT	1MF 20% 50V
C360	1-163-021-91	CERAMIC CHIP	0.01MF 10% 50V (KV-29AL40/KV-29AL40C)	C501	1-102-112-00	CERAMIC	330PF 10% 50V
C361	1-163-037-11	CERAMIC CHIP	0.022MF 10% 50V (KV-29AL40/KV-29AL40C)	C502	1-106-383-00	MYLAR	0.047MF 10% 200V
C362	1-126-964-11	ELECT	10MF 20% 50V (KV-29AL40/KV-29AL40C)	C503	1-102-212-00	CERAMIC	820PF 10% 500V
C373	1-163-038-91	CERAMIC CHIP	0.1MF 25V	C504	1-102-002-00	CERAMIC	680PF 10% 500V
C374	1-126-935-11	ELECT	470MF 20% 16V	C505 \triangle	1-162-134-11	CERAMIC	470PF 10% 2KV
				C507 \triangle	1-119-969-11	MYLAR	14000PF 3% 2KV
				C508 \triangle	1-107-364-11	MYLAR	0.01MF 10% 200V
				C509 \triangle	1-162-116-00	CERAMIC	680PF 10% 2KV
				C510	1-107-649-11	ELECT	2.2MF 20% 250V
				C511 \triangle	1-117-673-11	FILM	1.5MF 5% 200V
				C512	1-106-395-00	MYLAR	0.15MF 10% 200V
				C513	1-106-343-00	MYLAR	0.001MF 10% 100V
				C514	1-117-891-11	FILM	0.62MF 5% 200V
				C515 \triangle	1-162-116-00	CERAMIC	680PF 10% 2KV
				C520 \triangle	1-129-722-00	FILM	0.047MF 5% 630V
				C521	1-164-646-11	CERAMIC	2200PF 10% 500V
				C524	1-102-244-00	CERAMIC	220PF 10% 500V
				C525	1-162-815-11	CERAMIC	47PF 5% 500V
				C526	1-126-960-11	ELECT	1MF 20% 50V
				C527	1-126-965-11	ELECT	22MF 20% 50V
				C528	1-164-695-11	CERAMIC CHIP	0.0022MF 5% 50V
				C529	1-164-161-11	CERAMIC CHIP	0.0022MF 10% 50V
				C530	1-163-009-11	CERAMIC CHIP	0.001MF 10% 50V

Note:

The components identified with shading and a critical symbol Δ are critical for safety. Replace only with part number specified.

Note:

Les composants identifiés par un trame et une marque Δ sont critiques pour la sécurité. Ne les remplacer que par une pièce portant le numéro spécifié.



REF.NO.	PART NO.	DESCRIPTION	REMARK			REF.NO.	PART NO.	DESCRIPTION	REMARK
C531	1-106-387-00	MYLAR	0.068MF	10%	200V	CN203 *	1-560-124-00	PLUG, CONNECTOR (2.5MM) 4P	
C541	1-126-969-11	ELECT	220MF	20%	50V	CN250 *	1-564-514-11	PLUG, CONNECTOR 11P	
C542	1-126-967-11	ELECT	47MF	20%	50V	CN251	1-564-510-11	PLUG, CONNECTOR 7P	
C543	1-137-194-81	FILM	0.47MF	5%	50V	CN253	1-564-510-11	PLUG, CONNECTOR 7P	
C553	1-107-662-11	ELECT	22MF	20%	250V	CN301 *	1-564-509-11	PLUG, CONNECTOR 6P	
C555	1-164-161-11	CERAMIC CHIP	0.0022MF	10%	50V	CN501 *	1-580-798-11	CONNECTOR PIN (DY) 6P	
C562	1-126-941-11	ELECT	470MF	20%	25V	CN502 *	1-564-509-11	PLUG, CONNECTOR 6P	
C564	1-126-941-11	ELECT	470MF	20%	25V	CN601 *	1-580-843-11	PIN, CONNECTOR (POWER)	
C571	1-126-964-11	ELECT	10MF	20%	50V	CN602	1-508-786-00	PIN, CONNECTOR (5MM PITCH) 2P	
C573	1-126-963-11	ELECT	4.7MF	20%	50V	CN604 *	1-564-506-11	PLUG, CONNECTOR 3P	
C574	1-107-635-11	ELECT	4.7MF	20%	160V	<u>DIODE</u>			
C575	1-163-021-91	CERAMIC CHIP	0.01MF	10%	50V	D001	8-719-921-44	DIODE MTZJ-5.1C	
C576	1-123-024-21	ELECT	33MF		160V	D003	8-719-991-33	DIODE 1SS133T-77	
C581	1-126-963-11	ELECT	4.7MF	20%	50V	D004	8-719-991-33	DIODE 1SS133T-77	
C591	1-137-417-11	MYLAR	0.0047MF	10%	200V	D005	8-719-109-89	DIODE RD5.6ESB2	
C606 Δ	1-117-894-11	ELECT	560MF	20%	250V	D080	8-719-991-33	DIODE 1SS133T-77	
C607 Δ	1-117-894-11	ELECT	560MF	20%	250V	D205	8-719-982-22	DIODE MTZJ-30D	
C610	1-137-194-81	FILM	0.47MF	5%	50V	D207	8-719-109-66	DIODE RD3.3ESB2	
C611	1-137-194-81	FILM	0.47MF	5%	50V	D208	8-719-982-96	DIODE MTZJ-T-77-2.2A	
C612	1-164-735-11	CERAMIC	0.0015MF	10%	500V	D254	8-719-110-17	DIODE RD10ESB2	
C613	1-164-625-11	CERAMIC	680PF	10%	500V	D255	8-719-110-17	DIODE RD10ESB2	
C614 Δ	1-129-718-00	FILM	0.022MF	5%	630V	D302	8-719-921-44	DIODE MTZJ-5.1C	
C615	1-136-169-00	FILM	0.22MF	5%	50V	D303	8-719-991-33	DIODE 1SS133T-77	
C616	1-136-169-00	FILM	0.22MF	5%	50V	D305	8-719-404-49	DIODE MA111	
C617	1-165-127-11	CERAMIC	470PF	10%	500V	D306	8-719-404-49	DIODE MA111	
C618	1-165-127-11	CERAMIC	470PF	10%	500V	D403	8-719-991-33	DIODE 1SS133T-77	
C619	1-123-024-21	ELECT	33MF		160V	D501	8-719-945-80	DIODE ERC06-15S	
C620	1-126-942-61	ELECT	1000MF	20%	25V	D502	8-719-908-03	DIODE GP08D	
C621	1-126-941-11	ELECT	470MF	20%	25V	D503	8-719-908-03	DIODE GP08D	
C623	1-137-368-11	FILM	0.0047MF	5%	50V	D520	8-719-067-63	DIODE MDV04-600RL	
C624	1-137-417-11	MYLAR	0.0047MF	10%	200V	D521	8-719-302-43	DIODE EL1Z	
C626	1-104-665-11	ELECT	100MF	20%	25V	D522	8-719-991-33	DIODE 1SS133T-77	
C629	1-104-665-11	ELECT	100MF	20%	25V	D523	8-719-991-33	DIODE 1SS133T-77	
C632	1-126-964-11	ELECT	10MF	20%	50V	D541	8-719-908-03	DIODE GP08D	
C651	1-164-645-11	CERAMIC	1000PF	10%	500V	D550	8-719-110-08	DIODE RD8.2ESB2	
C653	1-104-664-11	ELECT	47MF	20%	25V	D551	8-719-991-33	DIODE 1SS133T-77	
C654	1-126-382-11	ELECT	100MF	20%	16V	D552	8-719-302-43	DIODE EL1Z	
C690	1-126-959-11	ELECT	0.47MF	20%	50V	D561	8-719-979-85	DIODE EGP20G	
C691	1-126-941-11	ELECT	470MF	20%	25V	D562	8-719-979-85	DIODE EGP20G	
C692	1-104-664-11	ELECT	47MF	20%	25V	D571	8-719-991-33	DIODE 1SS133T-77	
C693	1-137-194-81	FILM	0.47MF	5%	50V	D572	8-719-991-33	DIODE 1SS133T-77	
<u>FILTER</u>						D573	8-719-110-08	DIODE RD8.2ESB2	
CF001	1-767-487-11	VIBRATOR, CRYSTAL (KV-29AL40/KV-29AL40A)				D574 Δ	8-719-302-43	DIODE EL1Z	
<u>CONNECTOR</u>						D581	8-719-991-33	DIODE 1SS133T-77	
CN101	1-508-786-00	PIN, CONNECTOR (5MM PITCH) 2P				D601	8-719-510-51	DIODE D3SB60F	
						D602	8-719-991-33	DIODE 1SS133T-77	
						D604	8-719-060-90	DIODE S2L60F	

**Note:**

The components identified with shading and a critical symbol \triangle are critical for safety. Replace only with part number specified.

Note:

Les composants identifiés par un trame et une marque \triangle sont critiques pour la sécurité. Ne les remplacer que par une pièce portant le numéro spécifié.

REF.NO.	PART NO.	DESCRIPTION	REMARK
D605	8-719-060-90	DIODE S2L60F	
D610 \triangle	8-719-057-52	DIODE EZ0150AV1	
D615	8-719-510-12	DIODE D10SC4M	
D618	8-719-022-97	DIODE D2S4MF	
D620	8-719-022-97	DIODE D2S4MF	
D621	8-719-052-90	DIODE D1NL40-TA2	
D622	8-719-052-90	DIODE D1NL40-TA2	
D650	8-719-109-89	DIODE RD5.6ESB2	
D670	8-719-991-33	DIODE 1SS133T-77	
D690	8-719-991-33	DIODE 1SS133T-77	
D691	8-719-991-33	DIODE 1SS133T-77	
FERRITE BEAD			
FB350	1-216-295-91	SHORT	0 (KV-29AL40/KV-29AL40C)
FB501	1-410-396-41	FERRITE	0.45UH
FB521	1-410-397-21	FERRITE	1.1UH
FB522	1-410-397-21	FERRITE	1.1UH
FB601	1-410-396-41	FERRITE	0.45UH
FB602	1-410-396-41	FERRITE	0.45UH
FB603	1-412-911-11	FERRITE	0UH
FB605	1-412-911-11	FERRITE	0UH
IC			
IC001	8-759-562-90	IC M37273MF-251SP	
IC002	8-759-371-21	IC MM1319AFBE	
IC003	8-759-353-44	IC ST24C08FM6TR	
IC202	8-759-100-96	IC UPC4558G2	
IC203	8-759-534-81	IC MM1313AD/	
IC301	8-752-083-09	IC CXA2061S (KV-29AL40/KV-29AL40C)	
IC301	8-752-082-35	IC CXA2061S (KV-29AL40C)	
IC302	8-752-385-80	IC CXD2073S (KV-29AL40/KV-29AL40C)	
IC402	8-752-072-39	IC CXA2021S	
IC521 \triangle	8-759-700-07	IC NJM2903M	
IC541	8-759-980-58	IC TDA8172	
IC601 \triangle	8-729-039-65	TRANSISTOR MX0541B-F	
IC603 \triangle	8-749-012-13	IC DM-58	
IC604	8-759-198-03	IC PQ09RF21	
JACK			
J200	1-774-750-21	JACK BLOCK, PIN 2P	
J201	1-774-749-11	JACK BLOCK, PIN	
CHIP CONDUCTOR			
JR001	1-216-295-91	SHORT	0
JR003	1-216-295-91	SHORT	0
JR277	1-216-295-91	SHORT	0

REF.NO.	PART NO.	DESCRIPTION	REMARK
JR301	1-216-295-91	SHORT	0
JR344	1-216-295-91	SHORT	0
COIL			
L001	1-410-470-11	INDUCTOR	10UH
L002	1-412-032-11	INDUCTOR CHIP	100UH
L003	1-412-032-11	INDUCTOR CHIP	100UH
L101	1-412-029-11	INDUCTOR CHIP	10UH
L150	1-412-032-11	INDUCTOR CHIP	100UH
L151	1-412-029-11	INDUCTOR CHIP	10UH
L301	1-412-031-11	INDUCTOR CHIP	47UH
L302	1-412-029-11	INDUCTOR CHIP	10UH
L350	1-412-029-11	INDUCTOR CHIP	10UH (KV-29AL40/KV-29AL40C)
L351	1-412-031-11	INDUCTOR CHIP	47UH (KV-29AL40/KV-29AL40C)
L501 \triangle	1-411-976-11	COIL HORIZONTAL LINEARITY	
L502	1-412-552-11	INDUCTOR	2.2MMH
L503	1-406-677-11	INDUCTOR	0UH
L504	1-412-533-21	INDUCTOR	47UH
L520	1-409-955-11	INDUCTOR	0UH
L591 \triangle	1-412-528-61	INDUCTOR	18UH
IC LINK			
PS201	1-532-984-11	LINK, IC 2A/90V	
TRANSISTOR			
Q001	8-729-216-22	TRANSISTOR 2SA1162-G	
Q002	8-729-422-27	TRANSISTOR 2SD601A-Q	
Q081	8-729-216-22	TRANSISTOR 2SA1162-G	
Q200	8-729-422-27	TRANSISTOR 2SD601A-Q	
Q201	8-729-422-27	TRANSISTOR 2SD601A-Q	
Q203	8-729-119-76	TRANSISTOR 2SA1175-HFE	
Q204	8-729-422-27	TRANSISTOR 2SD601A-Q	
Q286	8-729-216-22	TRANSISTOR 2SA1162-G	
Q287	8-729-216-22	TRANSISTOR 2SA1162-G	
Q288	8-729-422-27	TRANSISTOR 2SD601A-Q	
Q300	8-729-422-27	TRANSISTOR 2SD601A-Q	
Q302	8-729-422-27	TRANSISTOR 2SD601A-Q	
Q305	8-729-216-22	TRANSISTOR 2SA1162-G	
Q306	8-729-216-22	TRANSISTOR 2SA1162-G	
Q307	8-729-216-22	TRANSISTOR 2SA1162-G	
Q308	8-729-216-22	TRANSISTOR 2SA1162-G	
Q309	8-729-216-22	TRANSISTOR 2SA1162-G	
Q310	8-729-216-22	TRANSISTOR 2SA1162-G	
Q350	8-729-216-22	TRANSISTOR 2SA1162-G (KV-29AL40/KV-29AL40C)	



REF.NO.	PART NO.	DESCRIPTION	REMARK	REF.NO.	PART NO.	DESCRIPTION	REMARK
Q351	8-729-422-27	TRANSISTOR 2SD601A-Q (KV-29AL40/KV-29AL40C)		R025	1-249-426-11	CARBON	5.6K 5% 1/4W
Q352	8-729-216-22	TRANSISTOR 2SA1162-G (KV-29AL40/KV-29AL40C)		R026	1-249-426-11	CARBON	5.6K 5% 1/4W
Q353	8-729-216-22	TRANSISTOR 2SA1162-G (KV-29AL40/KV-29AL40C)		R027	1-249-426-11	CARBON	5.6K 5% 1/4W
Q354	8-729-216-22	TRANSISTOR 2SA1162-G (KV-29AL40/KV-29AL40C)		R028	1-216-049-91	RES, CHIP	1K 5% 1/10W
Q355	8-729-422-27	TRANSISTOR 2SD601A-Q (KV-29AL40/KV-29AL40C)		R031	1-216-045-00	RES, CHIP	680 5% 1/10W
Q356	8-729-216-22	TRANSISTOR 2SA1162-G (KV-29AL40/KV-29AL40C)		R032	1-247-815-91	CARBON	220 5% 1/4W
Q357	8-729-216-22	TRANSISTOR 2SA1162-G (KV-29AL40/KV-29AL40C)		R033	1-247-815-91	CARBON	220 5% 1/4W
Q358	8-729-422-27	TRANSISTOR 2SD601A-Q (KV-29AL40/KV-29AL40C)		R034	1-216-033-00	RES, CHIP	220 5% 1/10W
Q359	8-729-216-22	TRANSISTOR 2SA1162-G (KV-29AL40/KV-29AL40C)		R035	1-216-033-00	RES, CHIP	220 5% 1/10W
Q360	8-729-216-22	TRANSISTOR 2SA1162-G (KV-29AL40/KV-29AL40C)		R038	1-216-049-91	RES, CHIP	1K 5% 1/10W
Q400	8-729-422-27	TRANSISTOR 2SD601A-Q		R040	1-249-413-11	CARBON	470 5% 1/4W
Q501	8-729-140-50	TRANSISTOR 2SC3209LK		R043	1-249-417-11	CARBON	1K 5% 1/4W
Q502	8-729-043-43	TRANSISTOR 2SC5426-01		R044	1-247-815-91	CARBON	220 5% 1/4W
Q521	8-729-422-27	TRANSISTOR 2SD601A-Q		R045	1-216-065-91	RES, CHIP	4.7K 5% 1/10W
Q522	8-729-809-29	TRANSISTOR 2SC4159-E		R046	1-247-815-91	CARBON	220 5% 1/4W
Q550	8-729-119-78	TRANSISTOR 2SC2785-HFE		R047	1-216-065-91	RES, CHIP	4.7K 5% 1/10W
Q555	8-729-422-27	TRANSISTOR 2SD601A-Q		R048	1-216-025-91	RES, CHIP	100 5% 1/10W
Q571	8-729-200-17	TRANSISTOR 2SA1091-O		R049	1-216-089-91	RES, CHIP	47K 5% 1/10W
Q601	8-729-119-78	TRANSISTOR 2SC2785-HFE		R050	1-216-073-00	RES, CHIP	10K 5% 1/10W
Q604	8-729-119-78	TRANSISTOR 2SC2785-HFE		R051	1-216-033-00	RES, CHIP	220 5% 1/10W
Q608	8-729-119-76	TRANSISTOR 2SA1175-HFE		R054	1-216-073-00	RES, CHIP	10K 5% 1/10W
Q650	8-729-111-55	TRANSISTOR 2SD1312-K		R056	1-249-425-11	CARBON	4.7K 5% 1/4W
Q670	8-729-140-96	TRANSISTOR 2SD774-34		R057	1-216-065-91	RES, CHIP	4.7K 5% 1/10W
		<u>RESISTOR</u>		R058	1-216-065-91	RES, CHIP	4.7K 5% 1/10W
R001	1-216-033-00	RES, CHIP	220 5% 1/10W	R070	1-249-425-11	CARBON	4.7K 5% 1/4W
R002	1-216-073-00	RES, CHIP	10K 5% 1/10W	R071	1-216-065-91	RES, CHIP	4.7K 5% 1/10W
R003	1-216-033-00	RES, CHIP	220 5% 1/10W	R073	1-249-425-11	CARBON	4.7K 5% 1/4W
R004	1-216-073-00	RES, CHIP	10K 5% 1/10W	R074	1-216-073-00	RES, CHIP	10K 5% 1/10W
R005	1-216-025-91	RES, CHIP	100 5% 1/10W	R075	1-216-073-00	RES, CHIP	10K 5% 1/10W
R006	1-216-049-91	RES, CHIP	1K 5% 1/10W	R076	1-216-121-91	RES, CHIP	1M 5% 1/10W
R007	1-216-025-91	RES, CHIP	100 5% 1/10W	R077	1-216-097-91	RES, CHIP	100K 5% 1/10W
R008	1-216-033-00	RES, CHIP	220 5% 1/10W	R081	1-249-413-11	CARBON	470 5% 1/4W (KV29AL40A)
R010	1-216-033-00	RES, CHIP	220 5% 1/10W	R085	1-216-049-91	RES, CHIP	1K 5% 1/10W
R011	1-216-033-00	RES, CHIP	220 5% 1/10W	R086	1-216-045-00	RES, CHIP	680 5% 1/10W
R013	1-216-081-00	RES, CHIP	22K 5% 1/10W	R087	1-216-045-00	RES, CHIP	680 5% 1/10W
R016	1-216-041-00	RES, CHIP	470 5% 1/10W	R088	1-216-045-00	RES, CHIP	680 5% 1/10W
R017	1-216-113-00	RES, CHIP	470K 5% 1/10W	R091	1-216-073-00	RES, CHIP	10K 5% 1/10W
R018	1-216-049-91	RES, CHIP	1K 5% 1/10W	R092	1-216-073-00	RES, CHIP	10K 5% 1/10W
R019	1-249-425-11	CARBON	4.7K 5% 1/4W	R096	1-216-045-00	RES, CHIP	680 5% 1/10W
				R101	1-216-073-00	RES, CHIP	10K 5% 1/10W
				R150	1-216-025-91	RES, CHIP	100 5% 1/10W
				R151	1-216-025-91	RES, CHIP	100 5% 1/10W
				R203	1-216-025-91	RES, CHIP	100 5% 1/10W
				R204	1-216-043-91	RES, CHIP	560 5% 1/10W
				R205	1-216-043-91	RES, CHIP	560 5% 1/10W
				R207	1-216-025-91	RES, CHIP	100 5% 1/10W
				R209	1-216-025-91	RES, CHIP	100 5% 1/10W



<u>REF.NO.</u>	<u>PART NO.</u>	<u>DESCRIPTION</u>	<u>REMARK</u>			<u>REF.NO.</u>	<u>PART NO.</u>	<u>DESCRIPTION</u>	<u>REMARK</u>		
R210	1-216-073-00	RES, CHIP	10K	5%	1/10W	R306	1-208-806-11	RES, CHIP	10K	0.50%	1/10W
R213	1-216-057-00	RES, CHIP	2.2K	5%	1/10W	R307	1-216-065-91	RES, CHIP	4.7K	5%	1/10W
R214	1-216-113-00	RES, CHIP	470K	5%	1/10W				(KV-29AL40/KV-29AL40C)		
R215	1-216-033-00	RES, CHIP	220	5%	1/10W	R307	1-216-075-00	RES, CHIP	12K	5%	1/10W
R216	1-216-113-00	RES, CHIP	470K	5%	1/10W				(KV-29AL40A)		
R217	1-216-033-00	RES, CHIP	220	5%	1/10W	R308	1-216-025-91	RES, CHIP	100	5%	1/10W
R218	1-216-067-00	RES, CHIP	5.6K	5%	1/10W				(KV-29AL40/KV-29AL40C)		
R219	1-216-073-00	RES, CHIP	10K	5%	1/10W	R310	1-216-049-91	RES, CHIP	1K	5%	1/10W
R220	1-216-073-00	RES, CHIP	10K	5%	1/10W	R312	1-216-033-00	RES, CHIP	220	5%	1/10W
R221	1-216-073-00	RES, CHIP	10K	5%	1/10W	R313	1-216-033-00	RES, CHIP	220	5%	1/10W
R222	1-216-067-00	RES, CHIP	5.6K	5%	1/10W	R314	1-216-033-00	RES, CHIP	220	5%	1/10W
R223	1-216-073-00	RES, CHIP	10K	5%	1/10W	R315	1-216-033-00	RES, CHIP	220	5%	1/10W
R224	1-216-073-00	RES, CHIP	10K	5%	1/10W	R316	1-247-807-31	CARBON	100	5%	1/4W
R225	1-216-073-00	RES, CHIP	10K	5%	1/10W	R317	1-216-025-91	RES, CHIP	100	5%	1/10W
R226	1-249-425-11	CARBON	4.7K	5%	1/4W				(KV-29AL40/KV-29AL40C)		
R227	1-216-097-91	RES, CHIP	100K	5%	1/10W	R318	1-216-025-91	RES, CHIP	100	5%	1/10W
R228	1-216-065-91	RES, CHIP	4.7K	5%	1/10W				(KV-29AL40/KV-29AL40C)		
R229	1-216-097-91	RES, CHIP	100K	5%	1/10W	R319	1-216-073-00	RES, CHIP	10K	5%	1/10W
R230	1-216-073-00	RES, CHIP	10K	5%	1/10W	R320	1-247-807-31	CARBON	100	5%	1/4W
R241	1-216-065-91	RES, CHIP	4.7K	5%	1/10W				(KV-29AL40/KV-29AL40C)		
R242	1-216-083-00	RES, CHIP	27K	5%	1/10W	R321	1-216-025-91	RES, CHIP	100	5%	1/10W
R243	1-216-689-11	RES, CHIP	39K	5%	1/10W				(KV-29AL40/KV-29AL40C)		
R244	1-216-049-91	RES, CHIP	1K	5%	1/10W	R322	1-216-025-91	RES, CHIP	100	5%	1/10W
R245	1-216-049-91	RES, CHIP	1K	5%	1/10W				(KV-29AL40/KV-29AL40C)		
R249	1-216-025-91	RES, CHIP	100	5%	1/10W	R323	1-216-037-00	RES, CHIP	330	5%	1/10W
R250	1-216-033-00	RES, CHIP	220	5%	1/10W	R324	1-216-065-91	RES, CHIP	4.7K	5%	1/10W
R251	1-216-025-91	RES, CHIP	100	5%	1/10W	R328	1-247-807-31	CARBON	100	5%	1/4W
R253	1-215-899-11	METAL OXIDE	15K	5%	2W F	R329	1-216-025-91	RES, CHIP	100	5%	1/10W
R256	1-216-033-00	RES, CHIP	220	5%	1/10W	R330	1-216-025-91	RES, CHIP	100	5%	1/10W
R257	1-249-429-11	CARBON	10K	5%	1/4W	R331	1-216-025-91	RES, CHIP	100	5%	1/10W
R258	1-216-033-00	RES, CHIP	220	5%	1/10W	R333	1-216-049-91	RES, CHIP	1K	5%	1/10W
R259	1-216-033-00	RES, CHIP	220	5%	1/10W	R334	1-216-025-91	RES, CHIP	100	5%	1/10W
R263	1-247-815-91	CARBON	220	5%	1/4W				(KV-29AL40/KV-29AL40C)		
R264	1-247-815-91	CARBON	220	5%	1/4W	R335	1-216-057-00	RES, CHIP	2.2K	5%	1/10W
R270	1-216-022-00	RES, CHIP	75	5%	1/10W	R336	1-216-057-00	RES, CHIP	2.2K	5%	1/10W
R271	1-216-113-00	RES, CHIP	470K	5%	1/10W	R337	1-216-057-00	RES, CHIP	2.2K	5%	1/10W
R272	1-216-113-00	RES, CHIP	470K	5%	1/10W	R340	1-249-417-11	CARBON	1K	5%	1/4W
R273	1-216-065-91	RES, CHIP	4.7K	5%	1/10W	R341	1-216-073-00	RES, CHIP	10K	5%	1/10W
R274	1-216-065-91	RES, CHIP	4.7K	5%	1/10W	R342	1-216-069-00	RES, CHIP	6.8K	5%	1/10W
R279	1-249-425-11	CARBON	4.7K	5%	1/4W	R343	1-216-129-00	RES, CHIP	2.2M	5%	1/10W
R297	1-216-043-91	RES, CHIP	560	5%	1/10W				(KV-29AL40/KV-29AL40C)		
R298	1-216-041-00	RES, CHIP	470	5%	1/10W	R345	1-216-129-00	RES, CHIP	2.2M	5%	1/10W
R299	1-249-425-11	CARBON	4.7K	5%	1/4W				(KV-29AL40/KV-29AL40C)		
R300	1-216-295-91	SHORT	0		(KV-29AL40A)	R346	1-216-129-00	RES, CHIP	2.2M	5%	1/10W
R302	1-216-295-91	SHORT	0		(KV-29AL40A)				(KV-29AL40/KV-29AL40C)		
R304	1-216-073-00	RES, CHIP	10K	5%	1/10W	R347	1-216-049-91	RES, CHIP	1K	5%	1/10W
R305	1-216-033-00	RES, CHIP	220	5%	1/10W	R350	1-208-766-11	RES, CHIP	220	0.50%	1/10W
									(KV-29AL40/KV-29AL40C)		
						R351	1-208-766-11	RES, CHIP	220	0.50%	1/10W
									(KV-29AL40/KV-29AL40C)		

**Note:**

The components identified with shading and a critical symbol \triangle are critical for safety. Replace only with part number specified.

Note:

Les composants identifiés par un trame et une marque \triangle sont critiques pour la sécurité. Ne les remplacer que par une pièce portant le numéro spécifique.

REF.NO.	PART NO.	DESCRIPTION	REMARK	REF.NO.	PART NO.	DESCRIPTION	REMARK
R352	1-208-794-11	RES, CHIP	3.3K 0.50% 1/10W (KV-29AL40/KV-29AL40C)	R380	1-208-790-11	RES, CHIP	2.2K 0.50% 1/10W (KV-29AL40/KV-29AL40C)
R353	1-216-295-91	SHORT	0 (KV-29AL40/KV-29AL40C)	R381	1-216-053-00	RES, CHIP	1.5K 5% 1/10W (KV-29AL40/KV-29AL40C)
R354	1-208-794-11	RES, CHIP	3.3K 0.50% 1/10W (KV-29AL40/KV-29AL40C)	R387	1-216-067-00	RES, CHIP	5.6K 5% 1/10W
R355	1-216-295-91	SHORT	0 (KV-29AL40/KV-29AL40C)	R388	8-719-976-99	DIODE DTZ5.1B	
R356	1-216-059-00	RES, CHIP	2.7K 5% 1/10W	R399	1-216-295-91	SHORT	0
R357	1-216-091-00	RES, CHIP	56K 5% 1/10W (KV-29AL40/KV-29AL40C)	R400	1-247-863-91	CARBON	22K 5% 1/4W
R358	1-216-043-91	RES, CHIP	560 5% 1/10W (KV-29AL40/KV-29AL40C)	R401	1-216-097-91	RES, CHIP	100K 5% 1/10W
R359	1-216-057-00	RES, CHIP	2.2K 5% 1/10W (KV-29AL40/KV-29AL40C)	R402	1-216-121-91	RES, CHIP	1M 5% 1/10W
R360	1-216-295-91	SHORT	0	R403	1-247-815-91	CARBON	220 5% 1/4W
R361	1-216-049-91	RES, CHIP	1K 5% 1/10W (KV-29AL40/KV-29AL40C)	R404	1-247-815-91	CARBON	220 5% 1/4W
R362	1-216-043-91	RES, CHIP	560 5% 1/10W (KV-29AL40/KV-29AL40C)	R405	1-216-097-91	RES, CHIP	100K 5% 1/10W
R363	1-216-037-00	RES, CHIP	330 5% 1/10W (KV-29AL40/KV-29AL40C)	R406	1-216-025-91	RES, CHIP	100 5% 1/10W
R364	1-216-025-91	RES, CHIP	100 5% 1/10W (KV-29AL40/KV-29AL40C)	R432	1-249-429-11	CARBON	10K 5% 1/4W
R365	1-216-025-91	RES, CHIP	100 5% 1/10W (KV-29AL40/KV-29AL40C)	R502	1-215-892-11	METAL OXIDE	1K 5% 2W F
R366	1-216-053-00	RES, CHIP	1.5K 5% 1/10W (KV-29AL40/KV-29AL40C)	R503	1-249-426-11	CARBON	5.6K 5% 1/4W F
R367	1-216-057-00	RES, CHIP	2.2K 5% 1/10W (KV-29AL40/KV-29AL40C)	R504	1-216-349-00	METAL OXIDE	1 5% 1W F
R368	1-216-033-00	RES, CHIP	220 5% 1/10W (KV-29AL40/KV-29AL40C)	R505	1-249-401-11	CARBON	47 5% 1/4W
R369	1-216-041-00	RES, CHIP	470 5% 1/10W (KV-29AL40/KV-29AL40C)	R506	1-215-860-11	METAL OXIDE	33 5% 1W F
R370	1-216-033-00	RES, CHIP	220 5% 1/10W	R507	1-260-097-11	CARBON	680 5% 1/2W
R372	1-216-035-00	RES, CHIP	270 5% 1/10W (KV-29AL40/KV-29AL40C)	R508	1-216-449-11	METAL OXIDE	56 5% 2W F
R373	1-216-025-91	RES, CHIP	100 5% 1/10W (KV-29AL40/KV-29AL40C)	R509	1-216-481-11	METAL OXIDE	1.2K 5% 3W F
R374	1-216-025-91	RES, CHIP	100 5% 1/10W (KV-29AL40/KV-29AL40C)	R510	1-216-449-11	METAL OXIDE	56 5% 2W F
R375	1-216-053-00	RES, CHIP	1.5K 5% 1/10W (KV-29AL40/KV-29AL40C)	R511	1-247-843-11	CARBON	3.3K 5% 1/4W
R376	1-216-049-91	RES, CHIP	1K 5% 1/10W (KV-29AL40/KV-29AL40C)	R520	1-215-861-00	METAL OXIDE	47 5% 1W F
R377	1-216-049-91	RES, CHIP	1K 5% 1/10W (KV-29AL40/KV-29AL40C)	R521	1-249-411-11	CARBON	330 5% 1/4W
R378	1-216-041-00	RES, CHIP	470 5% 1/10W (KV-29AL40/KV-29AL40C)	R522	1-249-415-11	CARBON	680 5% 1/4W
R379	1-216-049-91	RES, CHIP	1K 5% 1/10W (KV-29AL40/KV-29AL40C)	R523	1-216-073-00	RES, CHIP	10K 5% 1/10W
				R524	1-249-429-11	CARBON	10K 5% 1/4W
				R525	1-249-427-11	CARBON	6.8K 5% 1/4W
				R526	1-216-081-00	RES, CHIP	22K 5% 1/10W
				R527	1-216-079-00	RES, CHIP	18K 5% 1/10W
				R528	1-249-421-11	CARBON	2.2K 5% 1/4W
				R529	1-216-101-00	RES, CHIP	150K 5% 1/10W
				R530	1-216-089-91	RES, CHIP	47K 5% 1/10W
				R532	1-215-437-00	METAL	4.7K 1% 1/4W
				R533 \triangle	1-215-461-00	METAL	47K 1% 1/4W
				R534	1-215-451-00	METAL	18K 1% 1/4W
				R535	1-249-441-11	CARBON	100K 5% 1/4W
				R541	1-249-430-11	CARBON	12K 5% 1/4W
				R542	1-249-429-11	CARBON	10K 5% 1/4W
				R543	1-249-429-11	CARBON	10K 5% 1/4W
				R544	1-216-351-00	METAL OXIDE	1.5 5% 1W F
				R546	1-215-890-11	METAL OXIDE	470 5% 2W F
				R547	1-249-385-11	CARBON	2.2 5% 1/4W F
				R548	1-249-430-11	CARBON	12K 5% 1/4W
				R549	1-249-429-11	CARBON	10K 5% 1/4W

A

Note:

The components identified by \square in this manual have been carefully factory selected for each set in order to satisfy regulations regarding X-ray radiation. Should replacement be required, replace only with the value originally used.

Note:

The components identified with shading and a critical symbol \triangle are critical for safety. Replace only with part number specified.

Note:

Les composants identifiés par un trame et une marque \triangle sont critiques pour la sécurité. Ne les remplacer que par une pièce portant le numéro spécifié.

REF.NO.	PART NO.	DESCRIPTION	REMARK		
R550	1-249-421-11	CARBON	2.2K	5%	1/4W
R551	1-249-413-11	CARBON	470	5%	1/4W
R552	1-247-887-00	CARBON	220K	5%	1/4W
R553	1-260-312-11	CARBON	47	5%	1/2W
R554	1-216-101-00	RES, CHIP	150K	5%	1/10W (KV-29AL40/KV-29AL40C)
R555	1-216-093-00	RES, CHIP	68K	5%	1/10W (KV-29AL40/KV-29AL40C)
R556	1-216-081-00	RES, CHIP	22K	5%	1/10W (KV-29AL40/KV-29AL40C)
R557	1-249-431-11	CARBON	15K	5%	1/4W (KV-29AL40/KV-29AL40C)
R558	1-216-065-91	RES, CHIP	4.7K	5%	1/10W (KV-29AL40/KV-29AL40C)
R559	1-216-121-91	RES, CHIP	1M	5%	1/10W (KV-29AL40/KV-29AL40C)
R561 \triangle	1-249-377-11	CARBON	0.47	5%	1/4W F
R562 \triangle	1-260-288-11	CARBON	0.47	5%	1/2W
R571	1-216-365-00	METAL OXIDE	0.47	5%	2W F
R572	1-249-429-11	CARBON	10K	5%	1/4W
R573	1-247-895-91	CARBON	470K	5%	1/4W
R574	1-249-416-11	CARBON	820	5%	1/4W F
R575	1-247-895-91	CARBON	470K	5%	1/4W
R576	1-249-441-11	CARBON	100K	5%	1/4W
R578	1-215-902-11	METAL OXIDE	47K	5%	1W F
R579	1-208-777-11	RES, CHIP	620	0.50%	1/10W
R580	1-215-469-00	METAL	100K	1%	1/4W
R581	1-249-427-11	CARBON	6.8K	5%	1/4W
R582	1-208-806-11	RES, CHIP	10K	0.50%	1/10W
R583	1-208-830-11	RES, CHIP	100K	0.50%	1/10W
\square R584	1-208-822-11	RES, CHIP	47K	0.50%	1/10W
R585	1-216-073-00	RES, CHIP	10K	5%	1/10W
R586	1-216-073-00	RES, CHIP	10K	5%	1/10W
R587	1-216-073-00	RES, CHIP	10K	5%	1/10W
R591	1-215-882-00	METAL OXIDE	22	5%	2W F
R600	1-247-289-00	CARBON	8.2M	5%	1W (KV-29AL40A/KV-29AL40C)
R601 \triangle	1-219-513-11	CARBON	4.7M	5%	1/2W (KV-29AL40)
R602 \triangle	1-205-998-11	CEMENTED	1	5%	10W (KV-29AL40)
R602 \triangle	1-205-997-11	CEMENTED	2.2	5%	10W (KV-29AL40A/KV-29AL40C)
R603 \triangle	1-205-998-11	CEMENTED	1	5%	10W (KV-29AL40)
R603 \triangle	1-205-997-11	CEMENTED	2.2	5%	10W (KV-29AL40A/KV-29AL40C)
R604	1-260-131-11	CARBON	470K	5%	1/2W
R605	1-260-131-11	CARBON	470K	5%	1/2W
R606	1-220-926-11	FUSIBLE	0.47	10%	1/2W F
R608	1-220-388-21	METAL OXIDE	68K	5%	1W F
R609	1-220-388-21	METAL OXIDE	68K	5%	1W F
R610	1-220-388-21	METAL OXIDE	68K	5%	1W F
R611	1-220-388-21	METAL OXIDE	68K	5%	1W F
R612	1-216-349-00	METAL OXIDE	1	5%	1W F
R613	1-216-349-00	METAL OXIDE	1	5%	1W F
R618	1-212-857-00	FUSIBLE	10	5%	1/4W F
R622	1-249-393-11	CARBON	10	5%	1/4W
R623	1-249-441-11	CARBON	100K	5%	1/4W
R624	1-249-421-11	CARBON	2.2K	5%	1/4W
R630	1-249-421-11	CARBON	2.2K	5%	1/4W
R631	1-249-429-11	CARBON	10K	5%	1/4W
R641	1-216-389-11	METAL OXIDE	1	5%	3W F
R642	1-249-437-11	CARBON	47K	5%	1/4W
R647	1-249-429-11	CARBON	10K	5%	1/4W
R650	1-249-415-11	CARBON	680	5%	1/4W
R653	1-216-389-11	METAL OXIDE	1	5%	3W F
R670	1-249-421-11	CARBON	2.2K	5%	1/4W
R671	1-249-417-11	CARBON	1K	5%	1/4W
R673	1-249-421-11	CARBON	2.2K	5%	1/4W
R674	1-247-863-91	CARBON	22K	5%	1/4W
R675	1-215-859-00	METAL OXIDE	22	5%	1W F
R690	1-216-355-11	METAL OXIDE	3.3	5%	1W F
R691	1-249-395-11	CARBON	15	5%	1/4W
R692	1-249-395-11	CARBON	15	5%	1/4W
R699	1-249-413-11	CARBON	470	5%	1/4W F
<u>RELAY</u>					
RY601 \triangle	1-755-018-11	RELAY			
RY602 \triangle	1-755-266-11	RELAY, AC POWER			
<u>SWITCH</u>					
SW501	1-572-707-11	SWITCH, LEVER			
<u>TRANSFORMER</u>					
T501	1-437-210-11	TRANSFORMER, HORIZONTAL DRIVE			
T502	1-431-731-11	TRANSFORMER, MODULATION			
T504 \triangle	1-453-268-11	FBT ASSY, NX-4005/IX4J4			
T602 \triangle	1-429-992-11	TRANSFORMER, CONVERTER (PRT)			
T603 \triangle	1-431-837-11	TRANSFORMER, CONVERTER (PIT)			
<u>THERMISTOR</u>					
THP601	1-809-539-11	THERMISTOR, POSITIVE (KV-29AL40)			
THP601	1-809-827-11	THERMISTOR, POSITIVE (KV-29AL40A/KV-29AL40C)			

Note:

The components identified with shading and a critical symbol \triangle are critical for safety. Replace only with part number specified.

Note:

Les composants identifiés par un trame et une marque \triangle sont critiques pour la sécurité. Ne les remplacer que par une pièce portant le numéro spécifié.



REF.NO.	PART NO.	DESCRIPTION	REMARK	REF.NO.	PART NO.	DESCRIPTION	REMARK
<u>TUNER</u>				<u>RESISTOR</u>			
TU101 \triangle	8-598-431-00	TUNER, FSS BTF-WA411		R1706	1-260-099-11	CARBON	1K 5% 1/2W
<u>VARISTOR</u>				R1707	1-260-099-11	CARBON	1K 5% 1/2W
VDR602	1-809-267-41	VARISTOR ERZV10D471		R1708	1-260-099-11	CARBON	1K 5% 1/2W
<u>CRYSTAL</u>				R1709	1-260-087-11	CARBON	100 5% 1/2W
X300	1-579-972-11	VIBRATOR, CRYSTAL (KV-29AL40A)		R1710	1-260-123-11	CARBON	100K 5% 1/2W
X301	1-567-505-11	OSCILLATOR, CRYSTAL		R1711	1-216-373-11	METAL OXIDE	2.2 5% 2W F
X302	1-579-973-11	VIBRATOR, CRYSTAL (KV-29AL40A)		R1712	1-216-375-00	METAL OXIDE	3.3 5% 2W F
<u>CV</u>				R1713	1-247-807-31	CARBON	100 5% 1/4W
*	A-1331-776-A	CV BOARD (COM), MOUNTED		R1714	1-247-807-31	CARBON	100 5% 1/4W
	4-382-854-11	SCREW (M3X10), P, SW (+)		R1715	1-247-807-31	CARBON	100 5% 1/4W
<u>CAPACITOR</u>				R1720	1-260-132-11	CARBON	560K 5% 1/2W
C1701	1-107-652-11	ELECT	10MF 20% 250V	<u>E</u>			
C1702	1-162-114-00	CERAMIC	0.0047MF 2KV	*	A-1343-525-A	E BOARD (VAR), MOUNTED	
C1705	1-107-667-11	ELECT	2.2MF 20% 160V	*	A-1343-526-A	E BOARD (VAR), MOUNTED	
<u>CONNECTOR</u>					1-533-223-11	HOLDER, FUSE	
CN1701 *	1-564-509-11	PLUG, CONNECTOR 6P		<u>CAPACITOR</u>			
CN1702	1-564-511-11	PLUG, CONNECTOR 8P		C5000	1-107-662-11	ELECT	22MF 20% 250V
CN1703	1-695-915-11	TAB (CONTACT)		C5002	1-107-662-11	ELECT	22MF 20% 250V
CN1704	1-695-915-11	TAB (CONTACT)		C5003	1-136-601-11	FILM	0.01MF 10% 630V
<u>DIODE</u>				C5004	1-130-471-00	MYLAR	0.001MF 5% 50V
D1704	8-719-901-83	DIODE 1SS83		C5006	1-130-471-00	MYLAR	0.001MF 5% 50V
D1705	8-719-901-83	DIODE 1SS83		C5007	1-130-467-00	MYLAR	470PF 5% 50V
D1706	8-719-901-83	DIODE 1SS83		C5008	1-130-471-00	MYLAR	0.001MF 5% 50V
D1708	8-719-302-43	DIODE EL1Z		C5009	1-126-965-11	ELECT	22MF 20% 50V
<u>IC</u>				C5010	1-115-804-91	ELECT	120MF 20% 35V
IC1701	8-759-535-08	IC TDA6108Q		C5020 \triangle	1-113-941-11	CERAMIC	0.0047MF 20% 125V
<u>JACK</u>				C5021	1-113-941-11	CERAMIC	0.0047MF 20% 125V (KV-29AL40/KV-29AL40A)
J1701	1-251-688-11	SOCKET, CRT		C5050 \triangle	1-136-311-11	FILM	0.47MF 20% 125V
<u>COIL</u>				<u>CONNECTOR</u>			
L1701	1-408-613-31	INDUCTOR	68UH	CN5000 *	1-580-843-11	PIN, CONNECTOR (POWER)	
				CN5001 *	1-564-506-11	PLUG, CONNECTOR 3P	
				CN5002 *	1-580-843-11	PIN, CONNECTOR (POWER)	
				CN5003	1-508-786-00	PIN, CONNECTOR (5MM PITCH) 2P	
				<u>DIODE</u>			
				D5001	8-719-911-55	DIODE U05G	
				D5002	8-719-911-55	DIODE U05G	

E HT HV**Note:**

The components identified with shading and a critical symbol \triangle are critical for safety. Replace only with part number specified.

Note:

Les composants identifiés par un trame et une marque \triangle sont critiques pour la sécurité. Ne les remplacer que par une pièce portant le numéro spécifié.

REF.NO.	PART NO.	DESCRIPTION	REMARK
D5003	8-719-948-45	DIODE ERA22-08	
D5004	8-719-991-33	DIODE 1SS133T-77	
D5005	8-719-991-33	DIODE 1SS133T-77	
D5006	8-719-109-93	DIODE RD6.2ESB2	
D5007	8-719-510-48	DIODE D1N20R	
D5008	8-719-063-70	DIODE D1N120U	

FUSE

F5050 \triangle	1-532-506-51	FUSE 6.3A/250V (KV-29AL40A/KV-29AL40C)	
F5050 \triangle	1-576-193-11	FUSE 6.3A/125V (KV-29AL40)	

TRANSISTOR

Q5001	8-729-044-30	TRANSISTOR 2SK2845-LB102	
Q5002	8-729-119-78	TRANSISTOR 2SC3311A	

RESISTOR

R5001	1-249-389-11	CARBON	4.7	5%	1/4W F
R5002	1-215-485-00	METAL	470K	1%	1/4W
R5003	1-240-205-91	CARBON	22M	5%	1/2W
R5007	1-249-421-11	CARBON	2.2K	5%	1/4W
R5008	1-249-429-11	CARBON	10K	5%	1/4W

R5009	1-249-437-11	CARBON	47K	5%	1/4W
R5010	1-249-415-11	CARBON	680	5%	1/4W
R5011	1-260-302-51	CARBON	6.8	5%	1/2W
R5012	1-249-417-11	CARBON	1K	5%	1/4W
R5013	1-249-415-11	CARBON	680	5%	1/4W

R5050	1-219-512-11	CARBON	2.2M	5%	1/2W
-------	--------------	--------	------	----	------

TRANSFORMER

T5001 \triangle	1-431-852-11	TRANSFORMER, CONVERTER (SRT)	
T5050 \triangle	1-424-220-11	TRANSFORMER, LINE FILTER	

VARISTOR

VDR505	1-801-074-41	VARISTOR ERZV10D271 (KV-29AL40)	
VDR505	1-809-267-41	VARISTOR ERZV10D471 (KV-29AL40A/KV-29AL40C)	

HT

* A-1372-482-A HT BOARD, MOUNTED

CONNECTOR

CN2201 * 1-564-518-11 PLUG, CONNECTOR 3P

REF.NO.	PART NO.	DESCRIPTION	REMARK
<u>RESISTOR</u>			
R2001	1-249-415-11	CARBON	680 5% 1/4W
R2002	1-249-416-11	CARBON	820 5% 1/4W
R2003	1-249-421-11	CARBON	2.2K 5% 1/4W
R2004	1-249-427-11	CARBON	6.8K 5% 1/4W
R2005	1-249-429-11	CARBON	10K 5% 1/4W
R2006	1-247-815-91	CARBON	220 5% 1/4W

SWITCH

S2001	1-572-198-11	SWITCH, KEYBOARD	
S2002	1-572-198-11	SWITCH, KEYBOARD	
S2003	1-572-198-11	SWITCH, KEYBOARD	
S2004	1-572-198-11	SWITCH, KEYBOARD	
S2005	1-572-198-11	SWITCH, KEYBOARD	

S2006	1-572-198-11	SWITCH, KEYBOARD	
S2007	1-572-198-11	SWITCH, KEYBOARD	

HV

* A-1372-483-A HV BOARD (VAR), MOUNTED

CAPACITOR

C1407	1-137-194-91	FILM	0.47MF	5%	50V
C1408	1-136-287-11	FILM	0.0047MF	5%	50V
C1409	1-137-194-81	FILM	0.47MF	5%	50V
C1410	1-126-964-11	ELECT	10MF	20%	50V
C1411	1-126-964-11	ELECT	10MF	20%	50V

C1412	1-126-964-11	ELECT	10MF	20%	50V
C1413	1-126-964-11	ELECT	10MF	20%	50V
C1416	1-106-375-12	MYLAR	0.022MF	99%	200V
C1417	1-137-414-11	FILM	0.0047MF	10%	100V
C1418	1-102-114-00	CERAMIC	470PF	10%	50V

C1419	1-130-495-00	FILM	0.1MF	5%	50V
C1420	1-137-371-11	FILM	0.015MF	5%	50V
C1421	1-102-121-00	CERAMIC	0.0022MF	10%	50V
C1422	1-137-414-11	FILM	0.0047MF	10%	100V
C1423	1-137-194-91	FILM	0.47MF	5%	50V

C1424	1-130-495-00	FILM	0.1MF	5%	50V
C1425	1-137-370-11	FILM	0.01MF	5%	50V
C1426	1-130-495-00	FILM	0.1MF	5%	50V
C1427	1-137-370-11	FILM	0.01MF	5%	50V
C1428	1-130-495-00	FILM	0.1MF	5%	50V

C1429	1-137-370-11	FILM	0.01MF	5%	50V
C1430	1-126-964-11	ELECT	10MF	20%	50V



REF.NO.	PART NO.	DESCRIPTION	REMARK			REF.NO.	PART NO.	DESCRIPTION	REMARK		
C1431	1-136-287-11	FILM	0.0047MF	5%	50V	R1430	1-215-461-00	METAL	47K	1%	1/4W
C1432	1-126-964-11	ELECT	10MF	20%	50V	R1431	1-249-429-11	CARBON	10K	5%	1/4W
C1437	1-126-964-11	ELECT	10MF	20%	50V	R1433	1-249-429-11	CARBON	10K	5%	1/4W
C2068	1-104-665-11	ELECT	100MF	20%	25V	R1434	1-215-445-00	METAL	10K	1%	1/4W
C2234	1-126-960-11	ELECT	1MF	20%	50V	R1435	1-249-431-11	CARBON	15K	5%	1/4W
C2235	1-126-960-11	ELECT	1MF	20%	50V	R2236	1-247-895-91	CARBON	470K	5%	1/4W
C2236	1-106-343-00	MYLAR	0.001MF	10%	200V	R2237	1-249-425-11	CARBON	4.7K	5%	1/4W
<u>CONNECTOR</u>						R2238	1-247-895-91	CARBON	470K	5%	1/4W
CN1405	1-564-510-11	PLUG, CONNECTOR 7P				R2239	1-249-425-11	CARBON	4.7K	5%	1/4W
CN1406 *	1-564-506-11	PLUG, CONNECTOR 3P				HZ					
CN2001 *	1-564-506-11	PLUG, CONNECTOR 3P				_____					
CN2200 *	1-564-514-11	PLUG, CONNECTOR 11P				_____					
<u>DIODE</u>						* A-1372-117-A HZ BOARD, MOUNTED (KV-29AL40A ONLY)					
D2006	1-810-039-11	LED UNIT (KV-29AL40A)				<u>CONNECTOR</u>					
D2006	1-810-039-21	LED UNIT (KV-29AL40/KV-29AL40C)				CN901 *	1-580-843-11	PIN, CONNECTOR (POWER)			
<u>IC</u>						CN902 *	1-580-843-11	PIN, CONNECTOR (POWER)			
IC1403	8-759-496-03	IC NJM2178L				<u>SWITCH</u>					
IC2003	8-742-014-11	HYB IC SBX1981-51				S901 \triangle	1-571-433-21	SWITCH, PUSH (AC POWER)			
<u>JACK</u>						K					
J2231	1-691-110-11	JACK, PIN 3P				_____					
<u>RESISTOR</u>						* A-1380-582-A K BOARD (VAR), MOUNTED					
R1403	1-215-437-00	METAL	4.7K	1%	1/4W	4-382-854-11 SCREW (M3X10), P, SW (+)					
R1404	1-249-419-11	CARBON	1.5K	5%	1/4W	<u>CAPACITOR</u>					
R1405	1-249-424-11	CARBON	3.9K	5%	1/4W	C1401	1-126-957-11	ELECT	0.22MF	20%	50V
R1406	1-249-437-11	CARBON	47K	5%	1/4W	C1402	1-126-957-11	ELECT	0.22MF	20%	50V
R1407	1-249-435-11	CARBON	33K	5%	1/4W	C1403	1-126-943-11	ELECT	2200MF	20%	25V
R1408	1-215-469-00	METAL	100K	1%	1/4W	C1404	1-126-943-11	ELECT	2200MF	20%	25V
R1409	1-249-417-11	CARBON	1K	5%	1/4W	C1405	1-126-382-11	ELECT	100MF	20%	16V
R1410	1-215-461-00	METAL	47K	1%	1/4W	C1406	1-126-382-11	ELECT	100MF	20%	16V
R1411	1-249-429-11	CARBON	10K	5%	1/4W	C1450	1-136-171-00	FILM	0.33MF	5%	50V
R1412	1-249-429-11	CARBON	10K	5%	1/4W	C1451	1-136-171-00	FILM	0.33MF	5%	50V
R1413	1-249-429-11	CARBON	10K	5%	1/4W	C1452	1-137-366-11	FILM	0.0022MF	5%	50V
R1414	1-249-429-11	CARBON	10K	5%	1/4W	C1453	1-137-366-11	FILM	0.0022MF	5%	50V
R1415	1-249-429-11	CARBON	10K	5%	1/4W	<u>CONNECTOR</u>					
R1416	1-249-429-11	CARBON	10K	5%	1/4W	CN1400 *	1-564-507-11	PLUG, CONNECTOR 4P			
R1417	1-249-429-11	CARBON	10K	5%	1/4W	CN1401 *	1-564-506-11	PLUG, CONNECTOR 3P			
R1419	1-249-441-11	CARBON	100K	5%	1/4W	CN1402	1-564-510-11	PLUG, CONNECTOR 7P			
R1420	1-249-429-11	CARBON	10K	5%	1/4W						
R1421	1-249-441-11	CARBON	100K	5%	1/4W						
R1422	1-249-429-11	CARBON	10K	5%	1/4W						
R1423	1-249-441-11	CARBON	100K	5%	1/4W						



<u>REF.NO.</u>	<u>PART NO.</u>	<u>DESCRIPTION</u>	<u>REMARK</u>	<u>REF.NO.</u>	<u>PART NO.</u>	<u>DESCRIPTION</u>	<u>REMARK</u>
<u>IC</u>							
IC1400	8-759-498-09	IC TDA1519AQU					
IC1401	8-759-498-09	IC TDA1519AQU					
<u>COIL</u>							
L1001	1-408-421-00	INDUCTOR	100MH				
L1002	1-410-470-11	INDUCTOR	10UH				
<u>IC LINK</u>							
PS1400	1-532-984-11	LINK, IC 2A/90V					
PS1401	1-532-984-11	LINK, IC 2A/90V					
<u>TRANSISTOR</u>							
Q1400	TRANSISTOR 2SC3311A						
<u>RESISTOR</u>							
R1401	1-249-429-11	CARBON	10K	5%	1/4W		
R1402	1-249-437-11	CARBON	47K	5%	1/4W		
R1433	1-249-421-11	CARBON	2.2K	5%	1/4W		
R1434	1-249-429-11	CARBON	10K	5%	1/4W		
R1435	1-249-429-11	CARBON	10K	5%	1/4W		
R1436	1-249-421-11	CARBON	2.2K	5%	1/4W		
R1437	1-247-863-91	CARBON	22K	5%	1/4W		
R1450	1-249-422-11	CARBON	2.7K	5%	1/4W		
R1451	1-249-422-11	CARBON	2.7K	5%	1/4W		
R1452	1-249-429-11	CARBON	10K	5%	1/4W		
R1453	1-249-429-11	CARBON	10K	5%	1/4W		
<u>ACCESSORY AND PACKING MATERIALS</u>							
	3-861-918-41	MANUAL, INSTRUCTION					
*	4-041-255-01	BAG, PROTECTION					
*	4-064-029-01	CUSHION ASSY, UPPER					
*	4-064-032-01	CUSHION ASSY, LOWER					
*	4-064-241-01	CARTON, INDIVIDUAL					
<u>REMOTE COMMANDER</u>							
	1-475-801-11	REMOTE COMMANDER (RM-Y165)					
	4-978-977-01	BATTERY COVER (FOR REMOTE)					

9-965-860-01

Sony Corporation
Sony Technology Center
Product Quality Division
Service Promotion Department

English
98IJ74117-1
Printed in U.S.A.
© 1998.9