

AE-6B SELF DIAGNOSTIC SOFTWARE

The identification of errors within the AE-6B chassis is triggered in one of two ways :- 1: Busy or 2: Device failure to respond to IIC. In the event of one of these situations arising the software will first try to release the bus if busy (Failure to do so will report with a continuous flashing LED) and then communicate with each device in turn to establish if a device is faulty. If a device is found to be faulty the relevant device number will be displayed through the LED (Series of flashes which must be counted) See table 1., non fatal errors are reported using this method.

Each time the software detects an error it is stored within the NVM. See Table 2.

Table 1

Error Message	LED Code
No error	00
Reserved	01
OCF (Over Current Protection)	02
Over Voltage Protection	03
No Vertical Sync	04
IKR Error at power on	05
IIC bus clock and/or data lines low at power on	06
NVM no IIC bus acknowledge at power on	07
Horizontal Protection	08
Tuner no acknowledge at power on	09
Sound Processor Error	10
Reserved	11
Scanrate Error	12
DAC Error	13
Backend Error	14
Dynamic Convergence Error	15
PIP Error	16

Flash Timing Example : e.g. error number 3

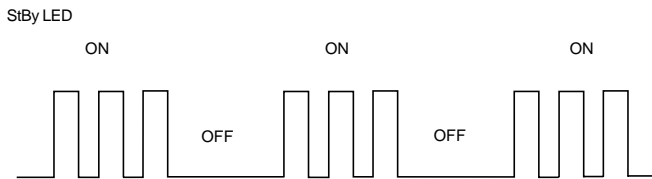

How to enter into Table 2

1. Turn on the main power switch of the TV set.
2. Program Remote Commander for Operation in Service Mode. [See Page 20].
2. Press 'VIDEO' 'VIDEO' > 'MENU' > ERROR MENU on the Remote Commander.
3. The following table will be displayed indicating the error count.

Table 2

ERROR MENU			
E02	OCF	(0, 255)	0
E03	OVP	(0, 255)	0
E04	VSYNC	(0, 255)	0
E05	IKR	(0, 255)	0
E06	IIC	(0, 255)	0
E07	NVM	(0, 255)	0
E08	HPROT	(0, 255)	0
E09	TUNER	(0, 255)	0
E10	SOUNDP	(0, 255)	0
E11	-	(0, 255)	0
E12	SCANRATE	(0, 255)	0
E13	DAC	(0, 255)	0
E14	BACKEND	(0, 255)	0
E15	DYN CON	(0, 255)	0
E16	PIP	(0, 255)	0
WORKING TIME			
HOURS			14
MINUTES			7

Note: To clear the error count data press '80' on the Remote commander.

SECTION 4 CIRCUIT ADJUSTMENTS

4-1. Electrical Adjustments

Service adjustments to this model can be performed using the supplied remote Commander RM-934.

Programming the Remote Commander for Operation in Service Mode

1. Press the VCR/TV/DVD button until the TV LED lights.
2. Press and hold the yellow button for approx. 5 seconds until the TV LED flashes quickly.
3. Press 99999. All three LED's should light. The remote commander is now set to Service Mode.
4. To return the remote commander to normal operation mode repeat steps 1. and 2. then press 00000. All three LED's should light. The remote commander is now set to normal mode.



Setting the TV into Service Mode

1. Program the remote commander for operation in Service Mode as described above.
2. Turn on the TV main power switch.
3. Press the video standby button  on the remote commander twice. 'TT __' will appear in the upper right corner of the screen. Other status information will also be displayed.
4. Press 'MENU' on the remote commander to obtain the following menu on the screen.

Geometry
Service
Scanrate
DAC
Dyn. Conv.
PIP
Sound
IF adjust
Error Menu
AE6B v0.14 (Jun 2001)
Factory data FFh FFh
MSP Device : MSP3411G

5. Move to the corresponding adjustment item using the up or down arrow buttons on the Remote Commander.
6. Press the right arrow button to enter into the required menu item.
7. Press the 'Menu' button on the Remote Commander to quit the Service Mode when all adjustments have been completed.

Note :

- After carrying out the service adjustments, to prevent the customer accessing the 'Service Menu' switch the TV set OFF and then ON.

GEOMETRY

ABL TH	(0, 3)	0
ABL MODE	(0, 3)	0
P ABL	(0, 15)	15
V SIZE	(0, 63)	35
V POSITION	(0, 63)	33
V COMP	(0, 3)	1
V LIN	(0, 15)	7
S CORRECTION	(0, 15)	7
H SIZE	(0, 63)	44
PIN AMP	(0, 63)	32
UP CORNERPIN	(0, 63)	29
M PIN	(0, 3)	2
LO CORNERPIN	(0, 63)	29
TRAPEZIUM	(0, 15)	2
H POSITION	(0, 63)	40
AFC BOW	(0, 15)	8
AFC ANGLE	(0, 15)	9
LEFT BLK	(0, 63)	34
RIGHT BLK	(0, 63)	17
V ASPECT	(0, 63)	47
AKBTIM1	(0, 3)	2
AKBTIM2	(0, 1)	0
IKR		1
HNG		0
VNG		0

DYN. CONV.

RANGE	(0, 63)	63
YupL	(0, 1)	0
VAL	(0, 63)	30
YlowL	(0, 1)	0
VAL	(0, 63)	31
MBOWupL	(0, 1)	0
VAL	(0, 63)	31
MBOWlowL	(0, 1)	0
VAL	(0, 63)	32
HAMPL	(0, 1)	0
VAL	(0, 63)	37
YupR	(0, 1)	0
VAL	(0, 63)	30
YlowR	(0, 1)	0
VAL	(0, 63)	30
MBOWupR	(0, 1)	0
VAL	(0, 63)	32
MBOWlowR	(0, 1)	0
VAL	(0, 63)	32
HAMPR	(0, 1)	0
VAL	(0, 63)	36
UP Y	(0, 1)	0
VAL	(0, 63)	31
LOW Y	(0, 1)	0
VAL	(0, 63)	33
H STAT	(0, 1)	0
VAL	(0, 63)	33
UP CORR	(0, 1)	0
VAL	(0, 63)	34
LOW CORR	(0, 1)	0
VAL	(0, 63)	19

IF ADJUST		
Automute		1
Audio Gain		0
L Gating		0

SERVICE		
SUB COL	(0, 63)	Adj 31
SUB HUE	(0, 63)	31
SUB SHARP	(0, 63)	30
SUB BRIGHT	(0, 63)	13
SUB CONT	(0, 15)	12
R-DRIVE	(0, 63)	50
G-DRIVE	(0, 63)	Adj
B-DRIVE	(0, 63)	Adj
R CUTOFF	(0, 63)	28
G CUTOFF	(0, 63)	24
B CUTOFF	(0, 63)	46
Br TXT	(0, 15)	7
Br OSD	(0, 15)	10

DAC		
CONFIG		00000000
MPIN CONT	(0, 255)	96
HLIN	(0, 255)	83
HTRAP	(0, 255)	127
ROT. COIL	(0, 255)	130
PHOCUS PH	(0, 255)	90

SOUND		
M-N	(0, 511)	200
M-D	(-128, -1)	-20
M-S	(+0, +127)	+20
S-M	(+0, +127)	+10
D-M	(-128, -1)	-10
N-M	(0, 1023)	496
BBE	(+0, +68)	+28
B1	(-96, +96)	+0
B2	(-96, +96)	+0
B3	(-96, +96)	+0
B4	(-96, +96)	+0
B5	(-96, +96)	+0
SW L	(-128, +0)	+0
SW F	(+5, +40)	+30
NICAM C AD		10001
NICAM Error	(0, 2047)	0
Stereo	(-128, +127)	+0
Status		000000110

ERROR MENU			
E02	OCP	(0, 255)	0
E03	OVP	(0, 255)	0
E04	VSUNC	(0, 255)	0
E05	IKR	(0, 255)	0
E06	IIC	(0, 255)	0
E07	NVM	(0, 255)	0
E08	HPR0T	(0, 255)	0
E09	TUNER	(0, 255)	0
E10	SOUNDP	(0, 255)	0
E11	-	(0, 255)	0
E12	SCANRATE	(0, 255)	0
E13	DAC	(0, 255)	0
E14	BACKEND	(0, 255)	0
E15	DYN CON	(0, 255)	0
E16	PIP	(0, 255)	0
WORKING TIME			
HOURS			14
MINUTES			7

Sub Brightness Adjustment

1. Input a Monoscope pattern.
2. Program the Remote Commander for operation in Service Mode. [See Page 20].
3. Press 'VIDEO' 'VIDEO' 13 on the Remote Commander.
4. Adjust the 'Sub-Brightness' data so that there is barely a difference between the 0 IRE and 10 IRE signal levels.

Sub Contrast Adjustment

1. Input a video signal that contains a small 100% white area on a black background.
2. Connect an digital voltmeter to Pin 10 of J7378 [C Board].
3. Program the Remote Commander for operation in Service Mode. [See Page 20].
4. Adjust the Sub-Contrast [Using 'VIDEO' 'VIDEO' '11'] to obtain a voltage of 105 +/- 5V.

Sub Colour Adjustment

1. Receive a PAL colour bar signal.
2. Connect an oscilloscope to Pin 6 of CN7001 [A Board].
3. Program the Remote Commander for operation in Service Mode. [See Page 20].
4. Adjust the 'Sub Colour' [Using 'VIDEO' 'VIDEO' '12'] so that the Cyan, Magenta and Blue colour bars are of equal levels as indicated below.

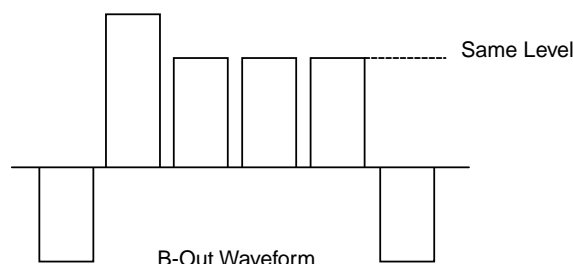

Deflection System Adjustment

1. Program the Remote Commander for operation in Service Mode. [See Page 20] and enter into the 'Geometry' service menu.
2. Select and adjust each item in order to obtain the optimum image.

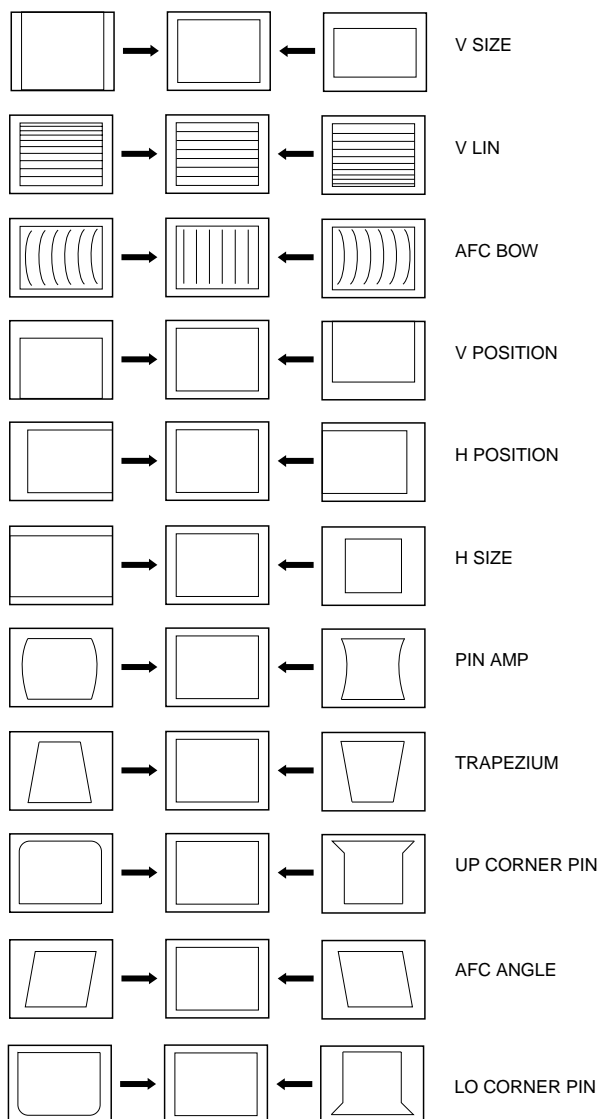

GEOMETRY		
ABL TH	(0, 3)	0
ABL MODE	(0, 3)	0
P ABL	(0, 15)	15
V SIZE	(0, 63)	35
V POSITION	(0, 63)	33
V COMP	(0, 3)	1
V LIN	(0, 15)	7
S CORRECTION	(0, 15)	7
H SIZE	(0, 63)	44
PIN AMP	(0, 63)	32
UP CORNERPIN	(0, 63)	29
M PIN	(0, 3)	2
LO CORNERPIN	(0, 63)	29
TRAPEZIUM	(0, 15)	2
H POSITION	(0, 63)	40
AFC BOW	(0, 15)	8
AFC ANGLE	(0, 15)	9
LEFT BLK	(0, 63)	34
RIGHT BLK	(0, 63)	17
V ASPECT	(0, 63)	47
AKBTIM1	(0, 3)	2
AKBTIM2	(0, 1)	0
IKR		1
HNG		0
VNG		0

4-3. TEST MODE 2:

Test Mode 2 is available by programming the Remote Commander for operation in Service Mode [As shown on Page 20] then pressing the 'VIDEO' button twice, OSD 'TT' appears. The functions described below are available by selecting the two numbers. To release the 'Test mode 2', press 00, 10, 20 ... twice or switch the TV set into Stand-by mode. In 'TT Menu' mode, it is possible to remove the Menu from the screen by pressing the Speaker Off button once. Pressing the Speaker OFF button a second time will cause the Menu to reappear. The function is kept even when the menu is not displayed on screen !!.

00	'TT' mode off
01	Picture maximum
02	Picture minimum
03	Set speaker/headphone Volume to 35%
04	Set speaker/headphone Volume to 50%
05	Set speaker/headphone Volume to 65%
06	Set speaker/headphone Volume to 80%
07	Ageing mode
08	Shipping Condition
11	Sub picture adjustment
12	Sub colour adjustment
13	Sub Brightness adjustment
14	Text H Position adjustment
15	Rotation Coil Test
16	Picture level 50%
19	Factory Mode Enable/Disable
21	Destination ADEKR
22	Destination BL
23	Destination ADEKR
24	Destination U
25	Destination ADEKR
26	Destination BL
27	Destination ADEKR
28	Destination ADEKR
31	Auto Shutoff Enable/Disable
36	Velocity Modulation (VM) OFF/ON test
41	Re-initialise NVM
43	Select Dual A sound
44	Select Dual B sound
45	Select Mono sound
46	Select Stereo sound
48	Set NVM as non virgin
49	Set NVM as virgin
53	FM Overmodulation Enable/Disable
55	Tuner selection (SONY/ALPS)
59	Select Model 3 Scarts + PIP or 2 Scarts
68	Enable/Disable X26 countermeasure (N problem)
73	Enable Zweiton D/K2 system (6.5/6.74)
74	Enable Zweiton D/K3 system (6.5/5.74)
78	Balance full right
79	Balance full left
87	Local keys test
99	Display Error and Working Time menu

5-1. BLOCK DIAGRAMS (1)

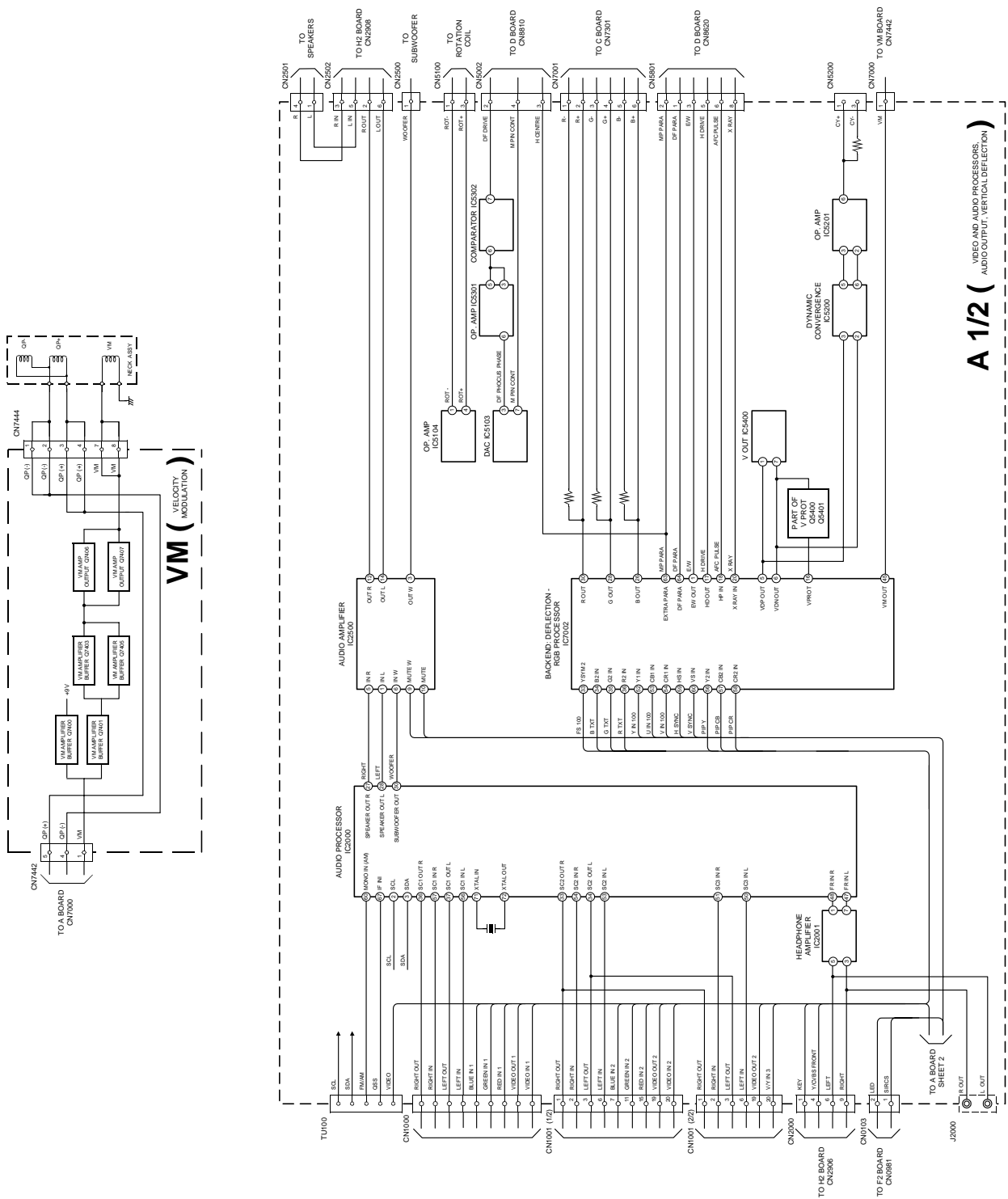

A 1/2 (VIDEO AND AUDIO PROCESSORS, AUDIO OUTPUT, VERTICAL DEFLECTION)

5-1. BLOCK DIAGRAMS (4)

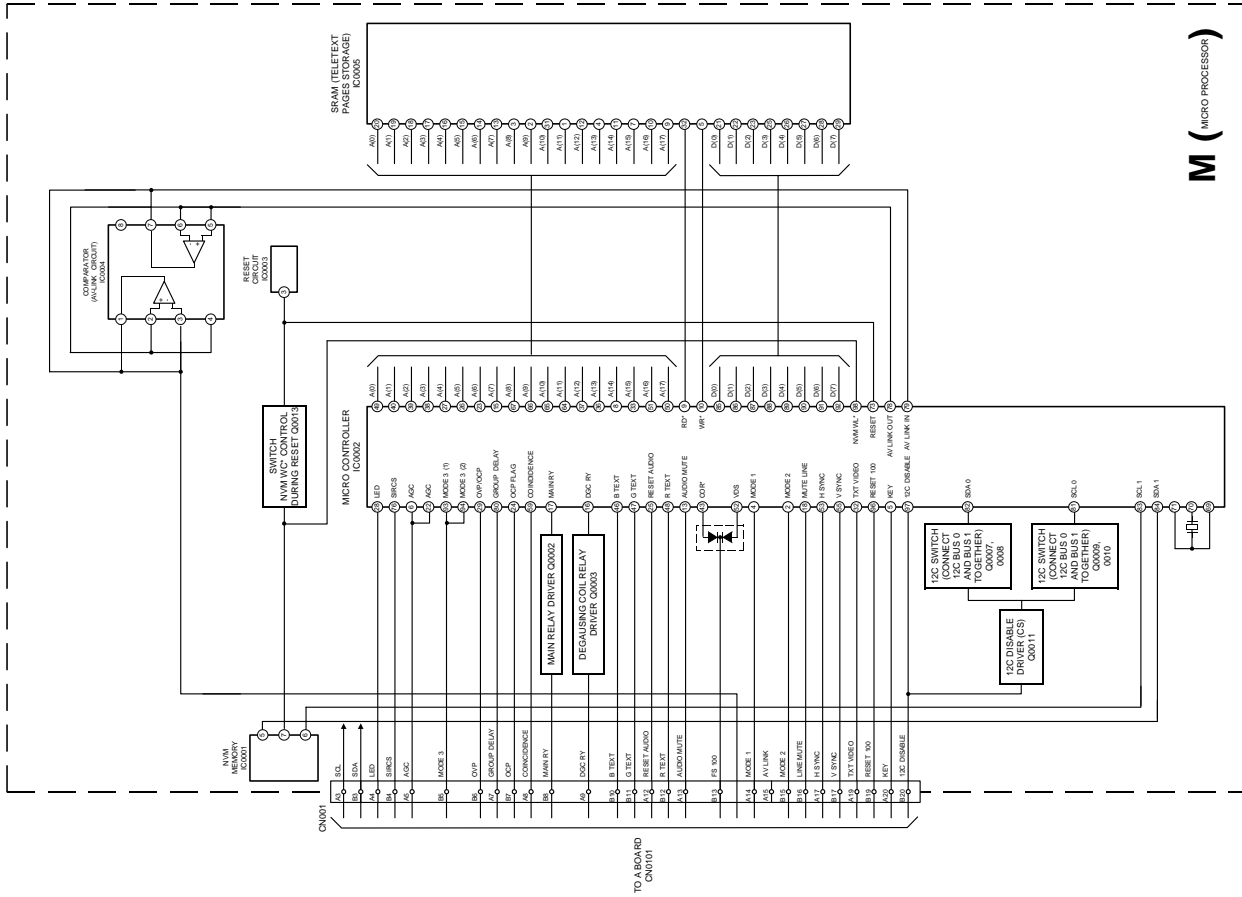

5-2. CIRCUIT BOARD LOCATION

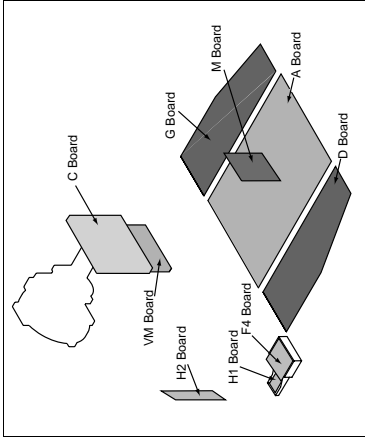

Reference Information

RESISTOR	RN	: METAL FILM
	RC	: SOLID
	FPRD	: NON FLAMMABLE CARBON
	FUSE	: NON FLAMMABLE FUSIBLE
	RS	: NON FLAMMABLE METAL OXIDE
	RB	: NON FLAMMABLE CEMENT
	RW	: NON FLAMMABLE WIREWOUND
	⊗	: ADJUSTMENT RESISTOR
COIL	LF-BL	: MICRO INDUCTOR
CAPACITOR	TA	: TANTALUM
	PS	: STYROL
	PP	: POLYPROPYLENE
	PT	: MYLAR
	MPS	: METALIZED POLYESTER
	MPP	: METALIZED POLYPROPYLENE
	ALB	: BIPOLAR
	ALT	: HIGH TEMPERATURE
	ALR	: HIGH RIPPLE

5-3. SCHEMATIC DIAGRAMS AND PRINTED WIRING BOARDS

- Note :**
- All capacitors are in μF unless otherwise noted.
 - pF : μF 50VV or less are not indicated except for electrolytic types.
 - Indication of resistance, which does not have one for rating electrical power, is as follows.

Pitch : 5mm
Electrical power rating : 1/4W

- Chip resistors are 1/10W
- All resistors are in ohms.
- $k = 1000$ ohms, $M = 1000,000$ ohms
- : nonflammable resistor.
- : fusible resistor.
- : internal component.
- : pane) designation or adjustment for repair.

- All variable and adjustable resistors have characteristic curve B, unless otherwise noted.
- All voltages are in Volts.
- Readings are taken with a 10Mohm digital multimeter.
- Readings are taken with a color bar input signal.
- Voltage variations may be noted due to normal production tolerances.

- : B - bus.
- : RF signal path.
- : earth - ground.
- : earth - chassis.

Note : The components identified by shading and marked Δ are critical for safety. Replace only with the part numbers specified in the parts list.

Note : Les composants identifiés par une trame et par une marque Δ sont d'une importance critique pour la sécurité. Ne les remplacer que par des pièces de numéro spécifié.

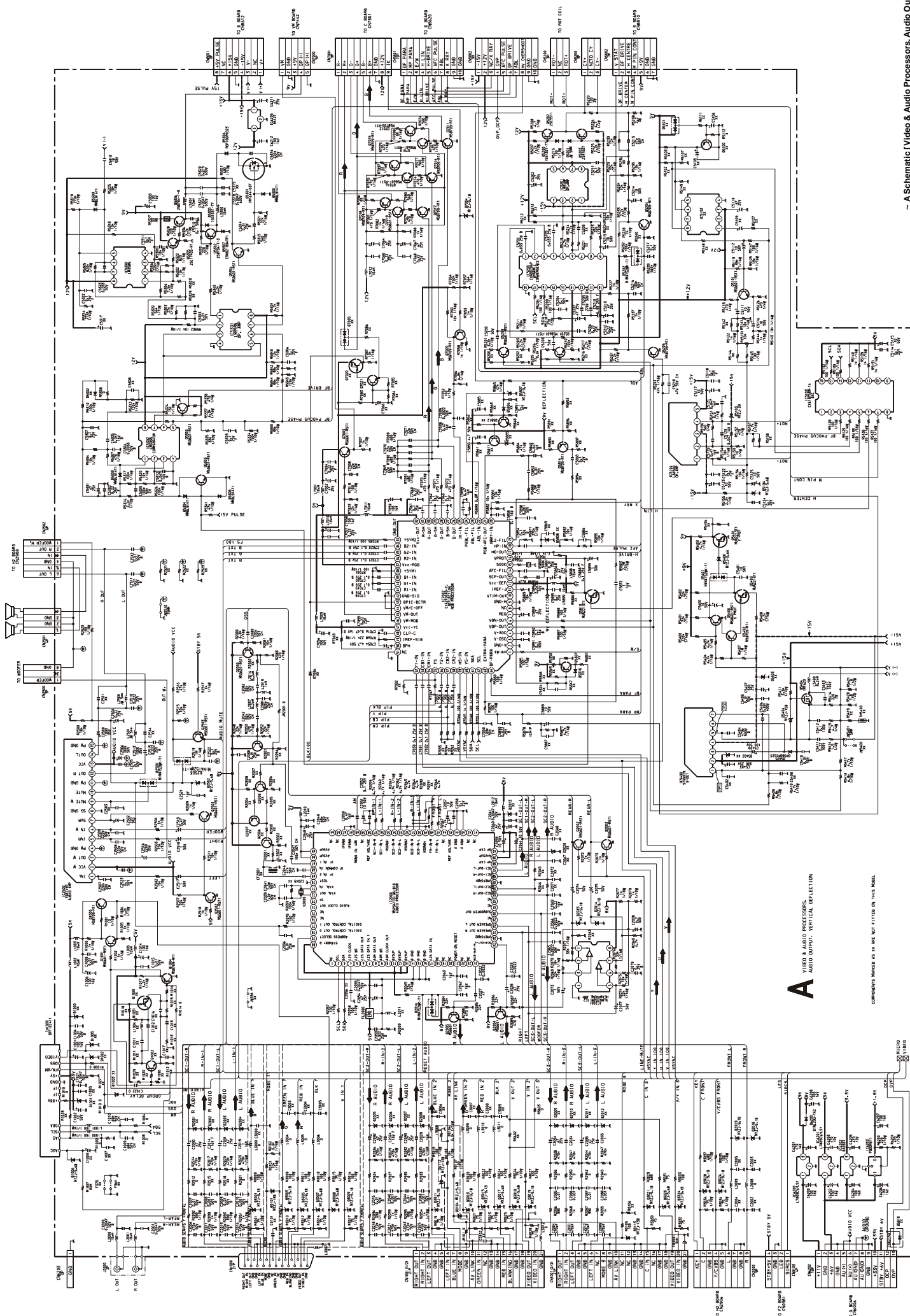

A
VIDEO & AUDIO PROCESSORS,
AUDIO OUTPUT, VERTICAL DEFLECTION

COMPONENTS MARKED AS 'M' ARE NOT FITTED ON THIS MODEL.

A B C D E F G H I J K L M N

~ H1 Board Schematic Diagram ~

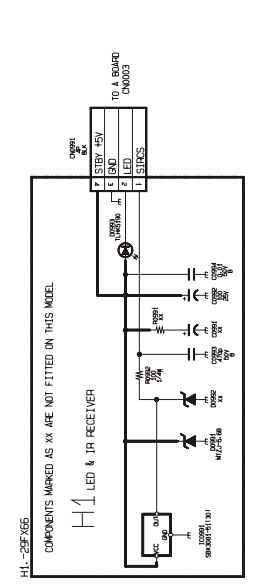

~ H2 Board Schematic Diagram ~

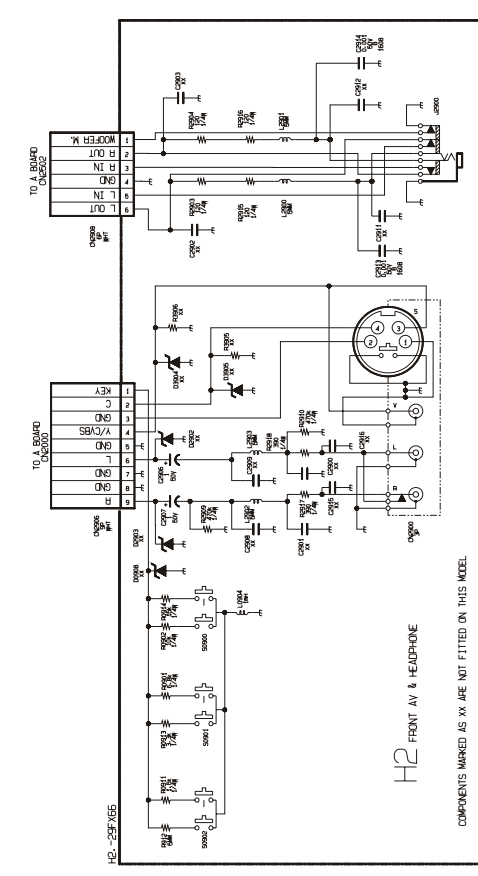

~ F4 Board Schematic Diagram ~

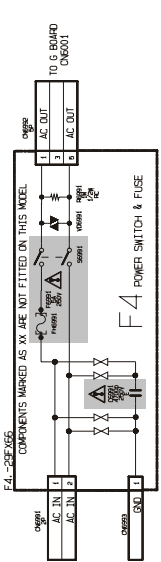

~ VM Board Schematic Diagram ~

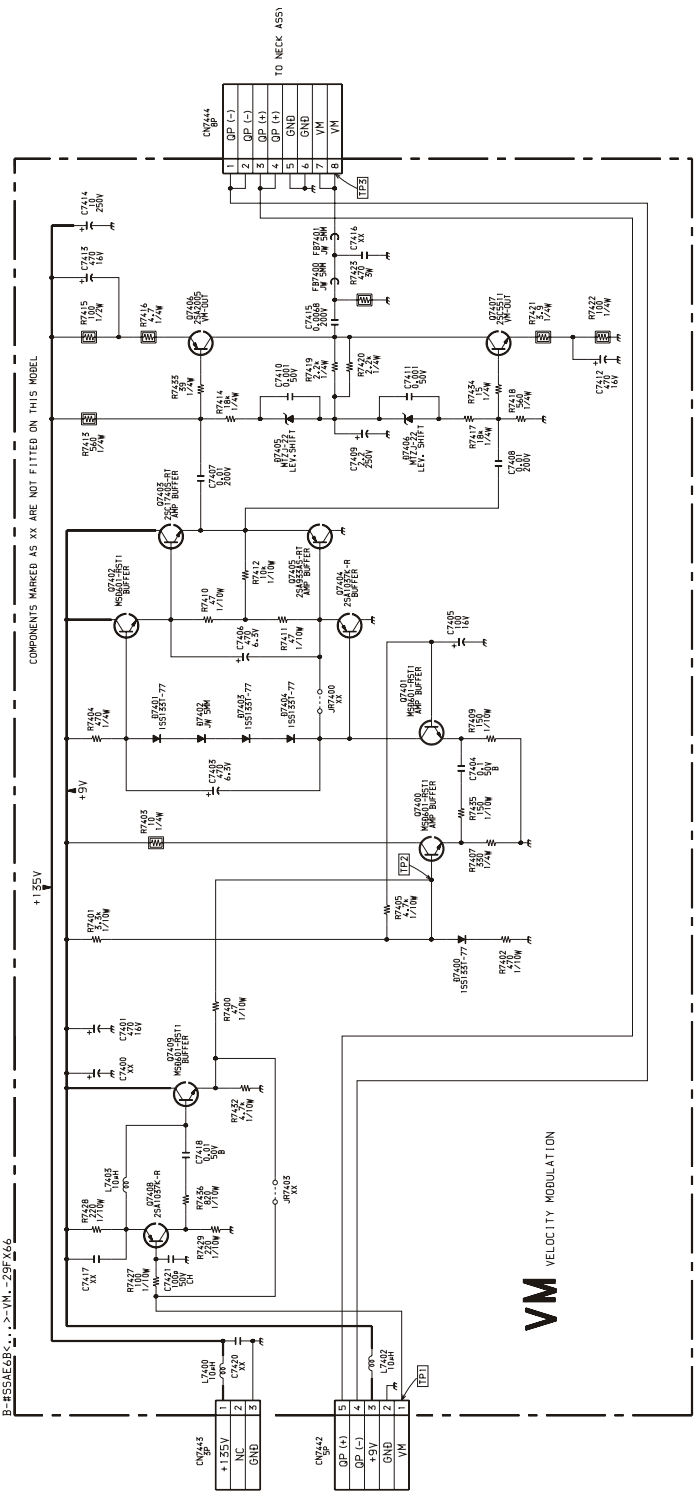

~ VM Board Schematic Diagram ~

~ G Schematic [Power Supply] ~

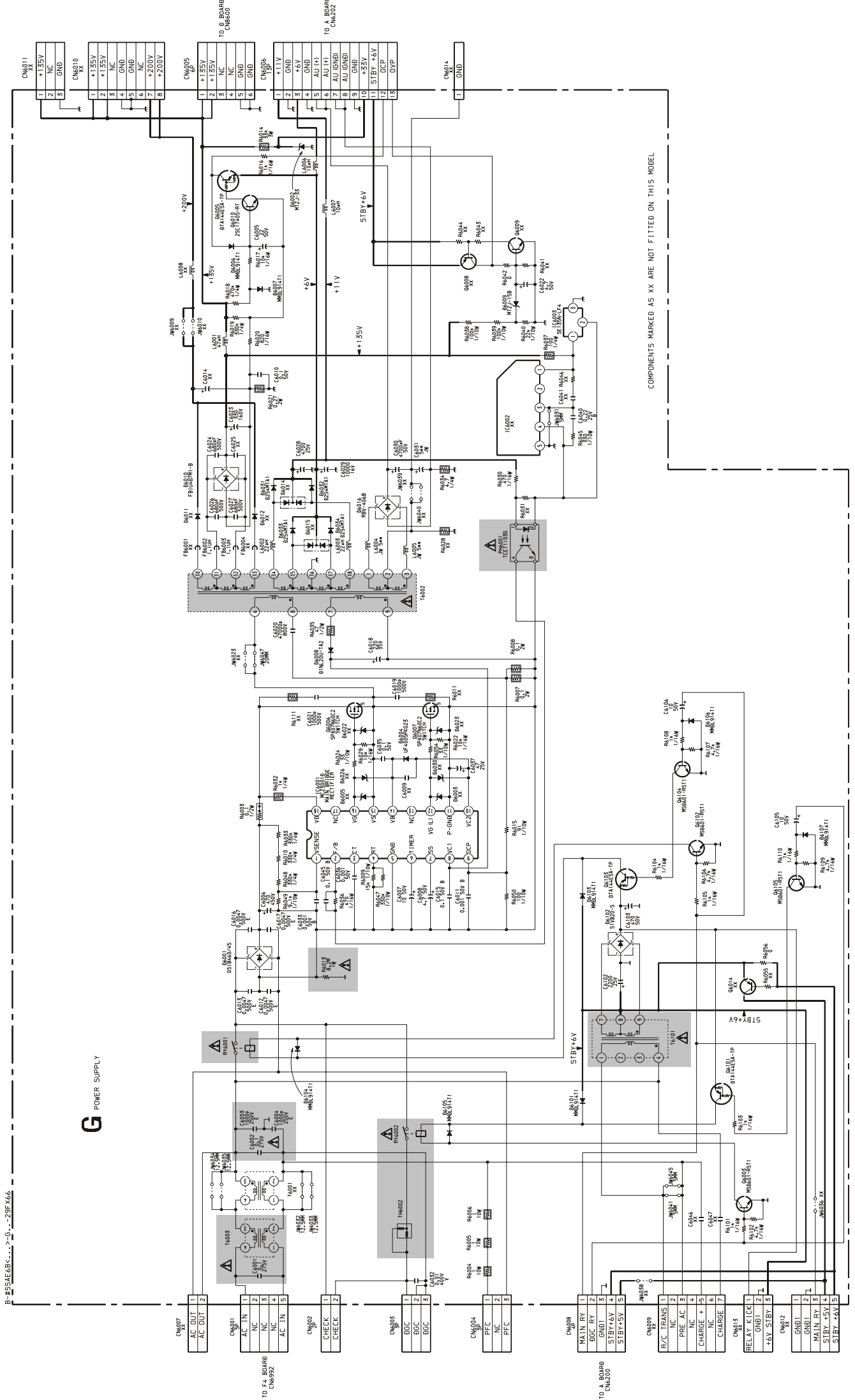

COMPONENTS MARKED AS XX ARE NOT FITTED ON THIS MODEL