

KV42

1.8°/step

□42mm NEMA17

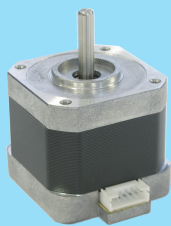

Applications

OA, FA, Medical Devices
Money-handling &
Banking equipment

SINGLE SHAFT

MODEL
KV4234-N2B801
KV4234-N2B802
KV4239-T2B801
KV4239-T2B802
KV4239-N2B801
KV4239-N2B802
KV4242-N2B801
KV4248-N2B801

*Low Vibration Type

*Low Vibration Type

OPTION

KV42LBS300

FEATURES

- High Speed · High Torque, Low Noise
- KH42-B900 Successor Model

SPECIFICATIONS

STEP ANGLE ° /step	VOLTAGE V	CURRENT A/PHASE	WINDING RESISTANCE Ω/PHASE	INDUCTANCE mH/PHASE	HOLDING TORQUE mN · m	ROTOR INERTIA g · cm ²	MODEL
1.8	2.76	1.2	2.3	3.6	260	42	KV4234-N2B801
1.8	4.00	0.8	5.0	7.5	260	42	KV4234-N2B802
1.8	2.94	1.4	2.1	4.5	300	59	KV4239-T2B801
1.8	4.88	0.8	6.1	14.0	300	59	KV4239-T2B802
1.8	2.94	1.4	2.1	4.1	370	59	KV4239-N2B801
1.8	4.88	0.8	6.1	14.0	370	59	KV4239-N2B802
1.8	3.72	1.2	3.1	5.0	420	69	KV4242-N2B801
1.8	3.90	1.3	3.0	6.1	530	79	KV4248-N2B801

GENERAL SPECIFICATIONS

INSULATION RESISTANCE	500V DC 100MΩ min. (at normal temp. & humidity, between lead and case)
DIELECTRIC STRENGTH	500V AC 50Hz 1min. (at normal temp. & humidity, between lead and case)
AMBIENT TEMP. AND HUMIDITY	-10°C~+50°C, 5%~95%RH (noncondensing)
STORAGE TEMP. AND HUMIDITY	-20°C~+70°C, 5%~95%RH (noncondensing)
TEMPERATURE RISE	80K max (By resistance method)
POSITION ACCURACY	±10%

SPEED-TORQUE CHARACTERISTICS

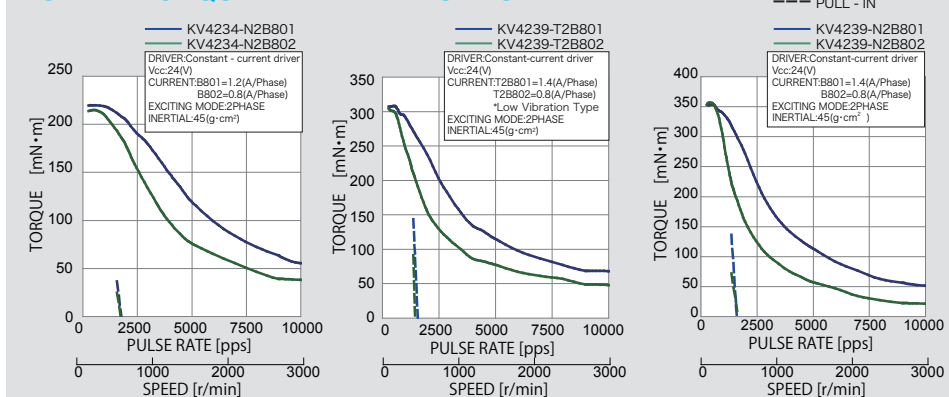

CW viewed from rotor shaft when using the following sequence diagram.

EXCITATION SEQUENCE

PHASE	1	2	3	4
A	-	+	+	-
B	-	-	+	+
\bar{A}	+	-	-	+
\bar{B}	+	+	-	-

CONNECTION DIAGRAMS

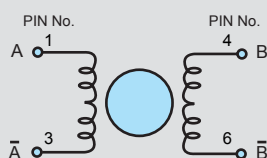

PHR-6 (PIN NO.)	1	3	4	6
PHASE	A	\bar{A}	B	\bar{B}
COLOR OF LEAD	RED	BLUE	YELLOW	WHITE

DIMENSIONS

Unit = mm

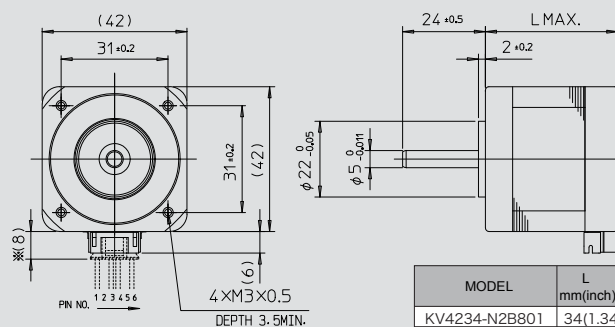

The KV42 motor is supplied without a leadwire assembly. This must be ordered as a separate part.

MODEL	L mm(inch)	mass kg
KV4234-N2B801	34(1.34)	0.21
KV4234-N2B802	34(1.34)	0.21
KV4239-T2B801	39(1.54)	0.26
KV4239-T2B802	39(1.54)	0.26
KV4239-N2B801	39(1.54)	0.26
KV4239-N2B802	39(1.54)	0.26
KV4242-N2B801	42(1.66)	0.32
KV4248-N2B801	48(1.89)	0.37

OPTION (Leadwire Assembly)

MODEL : KV42LBS300

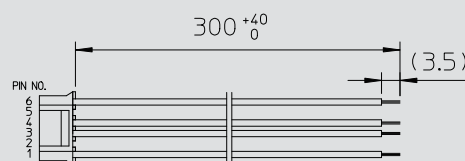

CONNECTOR SPECIFICATIONS

Maker	JST
Applicable Housing	PHR-6
Applicable Terminal	SPH-002T-P0.5S
Lead Wire	UL3266 AWG26