

Service Manual

Telephone Equipment

ABH and Caller ID Compatible

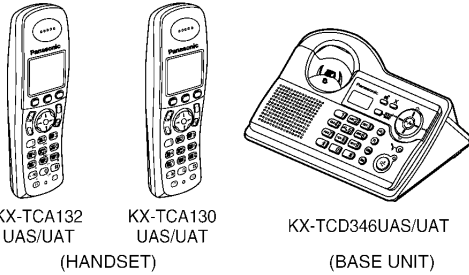

KX-TCA132
UAS/UAT

KX-TCA130
UAS/UAT

KX-TCD346UAS/UAT
(BASE UNIT)

- The difference between KX-TCA132 and KX-TCA130
KX-TCA132 has the icons for answering system printed below the dial keys.



(CHARGER UNIT)

Configuration for each model

Model No	Base Unit	Handset	Charger Unit
KX-TCD346	1	1 (TCA132)	
KX-TCA130		1 (TCA130)	1

KX-TCA130 is an optional accessory, which contains a handset and a charger.

KX-TCD346UAS
KX-TCD346UAT
KX-TCA132UAS
KX-TCA132UAT
KX-TCA130UAS
KX-TCA130UAT

Digital Cordless Answering System

Silver Version

Titanium Black Version

(for Ukraine)

SPECIFICATION

Standard:	DECT (Digital Enhanced Cordless Telecommunications) GAP (Generic Access Profile)	Power source:	AC Adaptor (220 V - 240 V AC, 50 Hz)
Number of channels:	120 Duplex Channels	Power consumption, Base Unit:	Standby: Approx. 3.8 W/Maximum: Approx. 9.2 W
Frequency range:	1.88 GHz to 1.9 GHz	Charger Unit:	Standby: Approx. 2.3 W/Maximum: Approx. 6.8 W
Duplex procedure:	TDMA (Time Division Multiple Access)	Battery life, Handset (if batteries are fully charged):	Stand-by: Up to 170 hours (Ni-MH) Talk: Up to 16 hours (Ni-MH)
Channel spacing:	1728 kHz	Operating conditions:	5 °C - 40 °C, 20 % - 80 % relative air humidity (dry)
Bit rate:	1152 kbit/s	Dimensions, Base Unit (D x W x L):	Approx. 86 mm x 183 mm x 122 mm
Modulation:	GFSK (Gaussian Frequency Shift Keying)	Dimensions, Handset (D x W x L):	Approx. 148 mm x 48 mm x 32 mm
RF Transmission power:	Approx. 250 mW	Dimensions, Charger Unit (D x W x L):	Approx. 85 mm x 94 mm x 65 mm
Voice coding:	ADPCM 32 kbit/s	Mass (weight), Base Unit:	Approx. 425 g
Operation range:	Up to 300 m outdoors, Up to 50 m indoors	Mass (weight), Handset:	Approx. 130 g
Analog telephone connection:	Telephone Line	Mass (weight), Charger Unit:	Approx. 90 g

Specifications are subject to change.

The illustrations used in this manual may differ slightly from the actual product.

IMPORTANT INFORMATION ABOUT LEAD FREE, (PbF), SOLDERING

If lead free solder was used in the manufacture of this product the printed circuit boards will be marked PbF. Standard leaded, (Pb), solder can be used as usual on boards without the PbF mark. When this mark does appear, please read and follow the special instructions described in this manual on the use of PbF and how it might be permissible to use Pb solder during service and repair work.

Panasonic

© 2005 Panasonic Communications Co., Ltd. All rights reserved. Unauthorized copying and distribution is a violation of law.

⚠ WARNING

This service information is designed for experienced repair technicians only and is not designed for use by the general public. It does not contain warnings or cautions to advise non-technical individuals of potential dangers in attempting to service a product. Products powered by electricity should be serviced or repaired only by experienced professional technicians. Any attempt to service or repair the product or products dealt with in this service information by anyone else could result in serious injury or death.

When you note the serial number, write down all 11 digits. The serial number may be found on the bottom of the unit.

Note:

Because CONTENTS 4 is the extract from the Operating Instructions of this model, it is subject to change without notice. You can download and refer to the original Operating Instructions on TSN Server for further information.

CONTENTS

	Page		Page
1 ABOUT LEAD FREE SOLDER (PbF: Pb free)	4	9.2. Troubleshooting for Speakerphone (Handset)	38
1.1. Suggested PbF Solder	4	9.3. The Setting Method of JIG (Handset)	39
1.2. How to recognize that Pb Free solder is used	5	9.4. Adjustment Standard (Handset)	40
2 FOR SERVICE TECHNICIANS	6	10 THINGS TO DO AFTER REPLACING IC	41
3 CAUTION	6	10.1. Base Unit	41
4 OPERATING INSTRUCTIONS	7	10.2. Handset	41
4.1. Battery	7	11 RF SPECIFICATION	42
4.2. Location of Controls	9	11.1. Base Unit	42
4.3. Connections	11	11.2. Handset	42
4.4. Guide to Settings	12	12 HOW TO CHECK THE SPEAKER OR RECEIVER	43
4.5. For Service Hint	13	13 FREQUENCY TABLE (MHz)	43
5 DISASSEMBLY INSTRUCTIONS	14	14 BLOCK DIAGRAM (BASE UNIT)	44
5.1. Base Unit	14	15 CIRCUIT OPERATION (BASE UNIT)	45
5.2. Handset	15	15.1. Outline	45
5.3. Charger Unit	16	15.2. Power Supply Circuit	46
6 ASSEMBLY INSTRUCTIONS	17	15.3. Telephone Line Interface	47
6.1. Fix the LCD to the Main P.C.Board (Handset)	17	15.4. Transmitter/Receiver	47
7 TROUBLESHOOTING FLOWCHART	18	15.5. Pulse Dialling	47
7.1. Check Power	19	16 BLOCK DIAGRAM (HANDSET)	48
7.2. Check Battery Charge	20	17 CIRCUIT OPERATION (HANDSET)	49
7.3. Check Link	21	17.1. Outline	49
7.4. Check Handset Transmission	25	17.2. Power Supply Circuit/Reset Circuit	49
7.5. Check Handset Reception	25	17.3. Charge Circuit	49
7.6. Check Caller ID	25	17.4. Battery Low/Power Down Detector	49
7.7. Check Base Speakerphone Transmission	25	17.5. Speakerphone	49
7.8. Check Base Speakerphone Reception	25	18 CIRCUIT OPERATION (CHARGER UNIT)	50
7.9. Bell Reception	26	18.1. Power Supply Circuit	50
7.10. Check TAM Operation	26	19 SIGNAL ROUTE	51
8 TROUBLESHOOTING BY SYMPTOM (BASE UNIT AND CHARGER UNIT)	27	20 CPU DATA (BASE UNIT)	53
8.1. Check Point (Base Unit)	27	20.1. IC4 (BBIC)	53
8.2. The Setting Method of JIG (Base Unit)	32	21 CPU DATA (HANDSET)	56
8.3. Adjustment Standard (Base Unit)	33	21.1. IC1 (BBIC)	56
8.4. Check Point (Charger Unit)	34	22 ENGINEERING MODE	58
8.5. Adjustment Standard (Charger Unit)	34	22.1. Base Unit	58
9 TROUBLESHOOTING BY SYMPTOM (HANDSET)	35	22.2. Handset	61
9.1. Check Point (Handset)	35	23 EEPROM LAYOUT (BASE UNIT)	63
		23.1. Scope	63

23.2. Introduction	63	31.3. Charger Unit	84
23.3. EEPROM Layout	63	31.4. Accessories and Packing Materials	85
24 EEPROM LAYOUT (HANDSET)	68	31.5. Fixtures and Tools	85
24.1. Scope	68	32 FOR SCHEMATIC DIAGRAM	87
24.2. Introduction	68	32.1. Base Unit (SCHEMATIC DIAGRAM (BASE UNIT_MAIN))	87
24.3. EEPROM contents	68	32.2. Handset (SCHEMATIC DIAGRAM (HANDSET))	87
25 HOW TO REPLACE THE FLAT PACKAGE IC	71	32.3. Charger Unit (SCHEMATIC DIAGRAM (CHARGER UNIT))	87
25.1. PREPARATION	71	33 SCHEMATIC DIAGRAM (BASE UNIT_MAIN)	88
25.2. FLAT PACKAGE IC REMOVAL PROCEDURE	71	34 SCHEMATIC DIAGRAM (BASE UNIT_OPERATION)	90
25.3. FLAT PACKAGE IC INSTALLATION PROCEDURE	72	35 SCHEMATIC DIAGRAM (HANDSET)	92
25.4. BRIDGE MODIFICATION PROCEDURE	72	36 SCHEMATIC DIAGRAM (CHARGER UNIT)	94
26 CABINET AND ELECTRICAL PARTS (BASE UNIT)	73	37 CIRCUIT BOARD (BASE UNIT_MAIN)	95
27 CABINET AND ELECTRICAL PARTS (HANDSET)	74	37.1. Component View	95
28 CABINET AND ELECTRICAL PARTS (CHARGER UNIT)	75	37.2. Flow Solder Side View	96
29 ACCESSORIES AND PACKING MATERIALS	76	38 CIRCUIT BOARD (BASE UNIT_OPERATION)	97
29.1. KX-TCD346UAS/UAT	76	38.1. Component View	97
29.2. KX-TCA130UAS/UAT	77	38.2. Flow Solder Side View	98
30 TERMINAL GUIDE OF THE ICs, TRANSISTORS AND DIODES	78	39 CIRCUIT BOARD (HANDSET)	99
30.1. Base Unit	78	39.1. Component View	99
30.2. Handset	78	39.2. Flow Solder Side View	100
30.3. Charger Unit	79	40 CIRCUIT BOARD (CHARGER UNIT)	101
31 REPLACEMENT PARTS LIST	80	40.1. Component View	101
31.1. Base Unit	80	40.2. Flow Solder Side View	101
31.2. Handset	83		

1 ABOUT LEAD FREE SOLDER (PbF: Pb free)

Note:

In the information below, Pb, the symbol for lead in the periodic table of elements, will refer to standard solder or solder that contains lead.

We will use PbF solder when discussing the lead free solder used in our manufacturing process which is made from Tin (Sn), Silver (Ag), and Copper (Cu).

This model, and others like it, manufactured using lead free solder will have PbF stamped on the PCB. For service and repair work we suggest using the same type of solder although, with some precautions, standard Pb solder can also be used.

Caution

- PbF solder has a melting point that is 50°F ~ 70°F (30°C ~ 40°C) higher than Pb solder. Please use a soldering iron with temperature control and adjust it to 700°F ± 20°F (370°C ± 10°C). In case of using high temperature soldering iron, please be careful not to heat too long.
- PbF solder will tend to splash if it is heated much higher than its melting point, approximately 1100°F (600°C).
- If you must use Pb solder on a PCB manufactured using PbF solder, remove as much of the original PbF solder as possible and be sure that any remaining is melted prior to applying the Pb solder.
- When applying PbF solder to double layered boards, please check the component side for excess which may flow onto the opposite side (See the figure below).

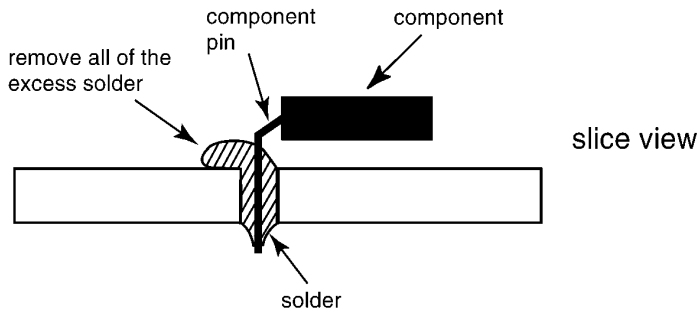

1.1. Suggested PbF Solder

There are several types of PbF solder available commercially. While this product is manufactured using Tin, Silver, and Copper (Sn+Ag+Cu), you can also use Tin and Copper (Sn+Cu) or Tin, Zinc, and Bismuth (Sn+Zn+Bi). Please check the manufacturer's specific instructions for the melting points of their products and any precautions for using their product with other materials.

The following lead free (PbF) solder wire sizes are recommended for service of this product: 0.3mm, 0.6mm and 1.0mm.

0.3mm X 100g	0.6mm X 100g	1.0mm X 100g

1.2. How to recognize that Pb Free solder is used

(Example: Handset P.C.B.)

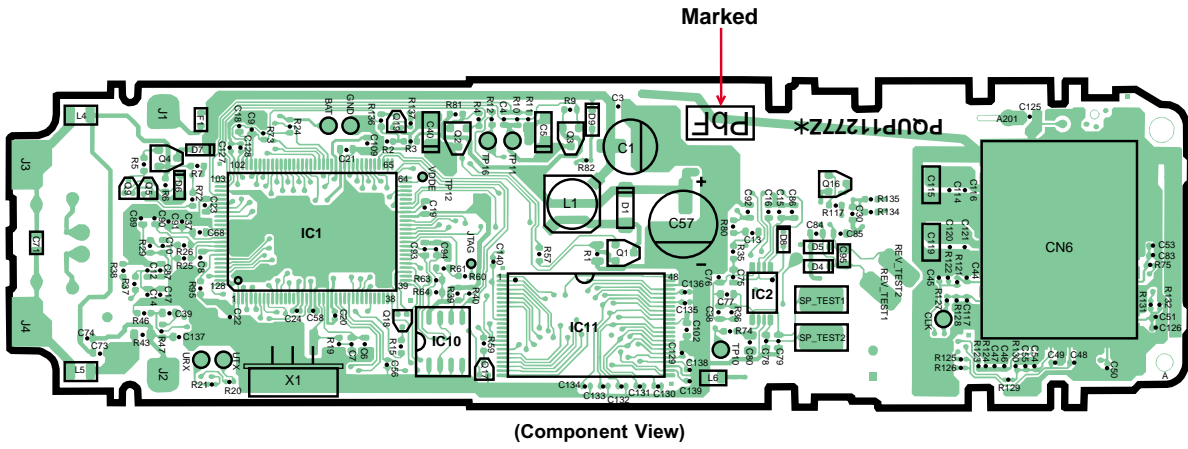

Note:

The location of the "PbF" mark is subject to change without notice.

2 FOR SERVICE TECHNICIANS

ICs and LSIs are vulnerable to static electricity.

When repairing, the following precautions will help prevent recurring malfunctions.

1. Cover the plastic parts boxes with aluminum foil and ground them.
2. Ground the soldering irons.
3. Use a conductive mat on the worktable.
4. Do not touch IC or LSI pins with bare fingers.

3 CAUTION

Danger of explosion if battery is incorrectly replaced. Replace only with the same or equivalent type recommended by the manufacturer.

Dispose of used batteries according to the manufacture's Instructions.

4 OPERATING INSTRUCTIONS

4.1. Battery

4.1.1. Battery Installation

1. Insert the batteries negative (⊖) terminal first.
2. Close the handset cover.

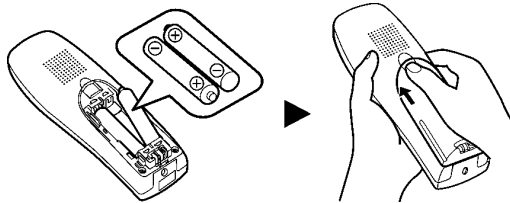

Note:

- Use only rechargeable Ni-MH batteries P03P (HHR-4EPT).





4.1.2. Battery Charge

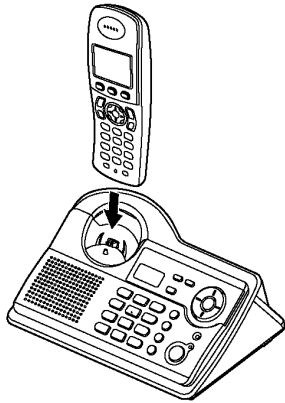

Place the handset on the base unit for about 7 hours before initial use.

When charging,  and battery strength icon are alternately shown on the display. When the batteries are fully charged,  remains on the display.



Battery icon	Battery strength
	High
	Medium
	Low When flashing: Needs to be charged.

Note:

- It is normal for the handset to feel warm during charging.
- It takes 7 hours to fully charge the batteries, however, you can use the handset before the batteries are fully charged.
- Clean the charge contacts of the handset and base unit with a soft, dry cloth, otherwise the batteries may not charge properly. Clean if the unit is exposed to grease, dust or high humidity.
- When  flashes, recharge the handset batteries.  will continue to flash until the batteries have been charged for at least 15 minutes.
- If the handset is turned off, it will be turned on automatically when it is placed on the base unit.

4.1.3. Battery Life

After your Panasonic batteries are fully charged, you can expect the following performance:

Ni-MH batteries (700 mAh)

Operation	Operating Time
While in use (talking)	16 hours max.
While not in use (standby)	170 hours max.

Note:

- Actual battery performance depends on a combination of how often the handset is in use (talking) and how often it is not in use (standby).
- Battery operating time may be shortened over time depending on usage conditions and ambient temperature.

4.1.4. Battery Replacement

If  flashes even after the handset batteries have been charged for 7 hours, the batteries must be replaced.

Important:

- We recommend the use of Panasonic rechargeable Ni-MH batteries P03P (HHR-4EPT). If you install non-rechargeable batteries and start charging, the batteries may leak electrolyte.
 - Do not mix old and new batteries.
1. Press the notch on the handset cover firmly and slide it in the direction of the arrow.
 2. Remove the old batteries positive (+) terminal first and install the new ones.

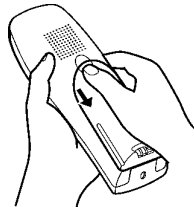

4.2. Location of Controls

4.2.1. Base Unit

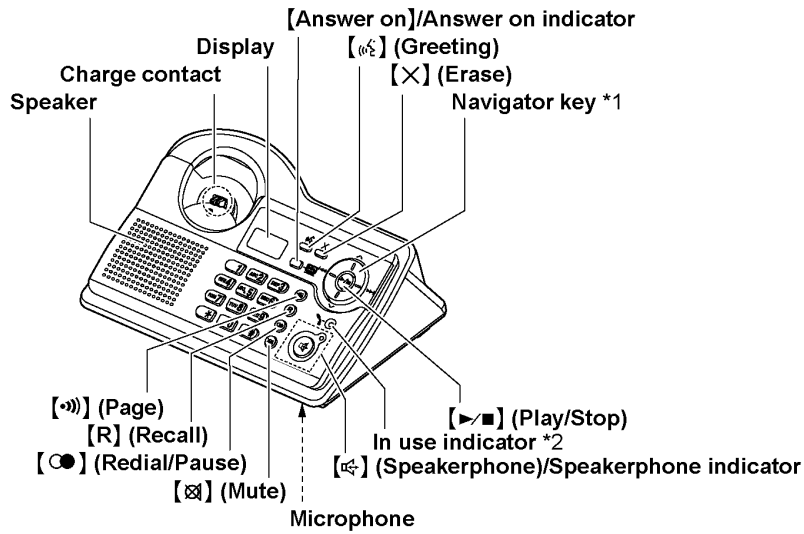

- *1: [▲][▼]: To adjust the ringer and speaker volumes.
[◀][▶]: To select the desired ringtone or to repeat or skip the recorded messages.
- *2: Lights when a handset is in use (on a call, editing the shared phonebook, using the answering system, etc.).
Flashes when a call is being received or when the answering system is answering a call.

4.2.2. Handset

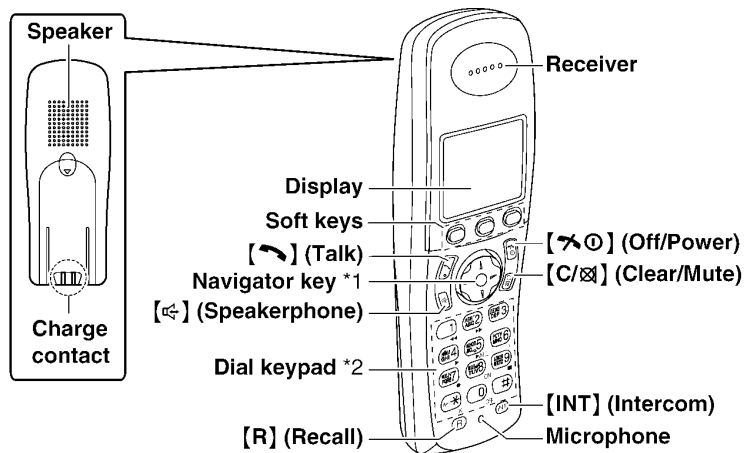

Model shown is KX-TCA132.

- *1: [▲][▼]: To search for the desired item in menus.
[▶]: To select the desired item or move the cursor to the right.
[◀]: To return to the previous screen or move the cursor to the left.
- *2: The icons printed below the dial keys shown in the illustration (▶, ☎, ■ etc.) indicate answering system operations.

Note:

- Up to 3 menu items can be displayed at a time. To select a menu item not shown on the current page, scroll up or down by pressing the navigator key, [▲] or [▼], respectively.

Handset Soft Keys

The handset features 3 soft keys. By pressing a soft key, you can select the feature or operation indicated by the soft key icon shown directly above it.

- Pressing the left, middle, or right soft key selects the leftmost, centre, or rightmost soft key icon respectively.
- The icons shown will vary depending on how you are using the unit.

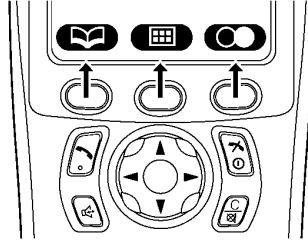

Handset Soft Key Icons

Soft Key icon	Action
	Returns to the previous screen.
	Displays the main menu.
	Accepts the current selection.
	Displays a previously dialled phone number.
	Opens the phonebook and switches between handset phonebook and shared phonebook.
	Displays the phonebook search menu.
	Turns the key lock feature off.
	Displayed when adding or editing a phonebook entry.
	Stops recording or playback.
	Inserts a dialling pause.
	Erases the selected item.
	Press when to receive caller information. (ABH subscribers only)
	Displayed when the soft key has no function.

4.3. Connections

4.3.1. Base Unit

When the AC adaptor is connected, a short beep will be heard. If it is not heard, check the connections.

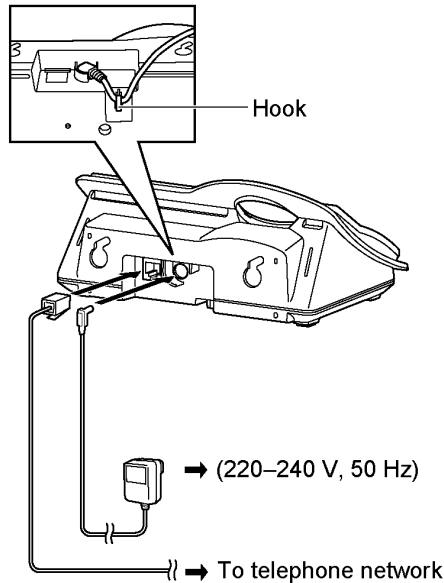

Important:

- Use only the AC adaptor PQLV19CEX and telephone line cord supplied with this unit.

Note:

- After connection, you must charge the batteries to make or answer calls with the handset.
- Never install telephone wiring during a lightning storm.
- The AC adaptor must remain connected at all times. (It is normal for the adaptor to feel warm during use.)
- The AC adaptor should be connected to a vertically oriented or floor-mounted AC outlet. Do not connect the AC adaptor to a ceiling-mounted AC outlet, as the weight of the adaptor may cause it to become disconnected.

4.3.2. Charger Unit

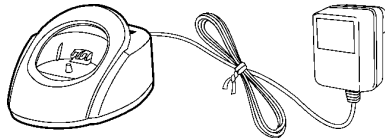

Important:

- Use only the AC adaptor PQLV200CEX.

Note:

- The AC adaptor must remain connected at all times (It is normal for the adaptor to feel warm during use).

4.4. Guide to Settings

For your reference, a chart of all items which can be customised for the base unit and the handset is printed below.

· When customising the base unit and the handset, the current item or setting is highlighted.

4.4.1. Base Unit Settings

· These items are customised using the handset.

Settings menu	Sub-menu	Sub-menu 2	Default setting	Remarks (selectable options)
Ringer Setup	Night Mode	Start/End	23:00/06:00	—
		On/Off	Off	On/Off
		Ring Delay	60 sec.	30/60/90/120 sec and No Ringing
Call Options	Dial Mode		Pulse	Tone/Pulse
	Recall		700 msec.	80/90/100/110/160/200/250/300/400/600/700/900 msec
	Pause Length		3 sec.	3 sec/5 sec
	Emergency No.		03, 01, 02, 04	Up to 5 numbers
	ARS Settings	Carrier Code	off	On (Up to 5 carrier codes)/Off
		Area Code	—	Up to 25 area codes
	Call Restrict		—	Up to 6 numbers
Call Bar		Off	On/Off	
ABH	Mode		ABH	ABH/Caller ID
	No. of Digits		7 digits	4~7 digits
	No. of Signals		3	1 to 5 times
	Signal Length		140	100 - 300 ms (divisible by 10)
	Signal Delay		200	100 - 900 ms (divisible by 50)
	1st. sig. Delay		200	100 - 900 ms (divisible by 50)
Other Options	Base Unit PIN		0000	—
	Repeater Mode		Off	On/Off
	Reset Base		—	—

Note:

· Up to 3 menu items can be displayed at a time. To select a menu item not shown on the current page, scroll up or down by pressing the navigator key, [▲] or [▼], respectively.

4.4.2. Answering System Settings

Answering system setting	Default setting	Remarks (selectable Options)
Answering system on/off	Answer On	Answer On/Answer Off
Remote access code	—	000~999/Off (✖)
Number of rings	4 Rings	Auto/2-7 Rings
Caller's recording time	3 Minutes	Greeting Only/1 Minute/3 Minutes
Call screening	On	On/Off
Message alert	Off	On/Off

4.4.3. Handset Settings

Settings menu	Sub-menu	Sub-menu 2	Default setting	Remarks (selectable options)
Time Settings	Set Date & Time		—	—
	Alarm		Off	Once/Daily/Off
Ringer Setup	Ringer Volume		Maximum**	Off/1 to 6**
	Ext. Ringtone (External ringtone)		Ringtone 1	1 to 20
	Int. Ringtone (Intercom ringtone)		Ringtone 1	1 to 20
	Night Mode	Start/End	23:00/06:00	—
		On/Off	Off	On/Off
		Ring Delay	60 sec.	30/60/90/120 sec and No Ringing
		Select Category	—	—
Display Setup	Wallpaper		Wallpaper1	Off/1 to 4
	Display Colour		Colour1	1 to 5
	Standby Display		Off	Base Number/Handset Nubmer/Off
	Select Language		YKPAĪHCbKA	6 languages selectable
	Contrast		Level 3**	Level 1 to Level 6**
Call Options	Call Bar		Off	On/Off
	Calling Code		—	24 digits max.
	Auto Talk		Off	On/Off
Registration	Register H.set (Register handset)		—	—
Select Base	—		Auto	Auto/Base 1/Base 2/Base 3/Base 4 *1
Other Options	Handset PIN		0000	—
	Keytones		On	On/Off
	Voice AOH		On	On/Off
	Reset Handset		—	—

*1 Here, only the case that a handset is registered to a maximum of 4 Base Units is mentioned.

Note:

- Up to 3 menu items can be displayed at a time. To select a menu item not shown on the current page, scroll up or down by pressing the navigator key, [▲] or [▼], respectively.
- The items with a mark “**” are not shown on the display.

4.5. For Service Hint

Items	Contents
Battery	You could use other rechargeable batteries sold in a market, but the unit is not guaranteed to work properly.
PIN Code	If you forget Base Unit or Handset PIN code, press *, 7, 0, 0, 0 as a PIN code. This is called “super password” and is effective when you have forgotten the PIN code.

5 DISASSEMBLY INSTRUCTIONS

5.1. Base Unit

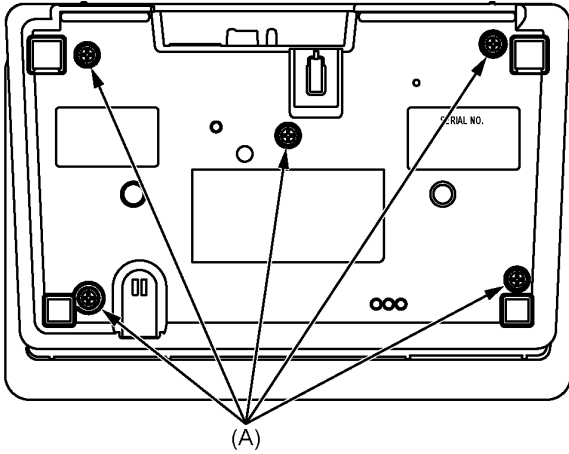

Fig. 1

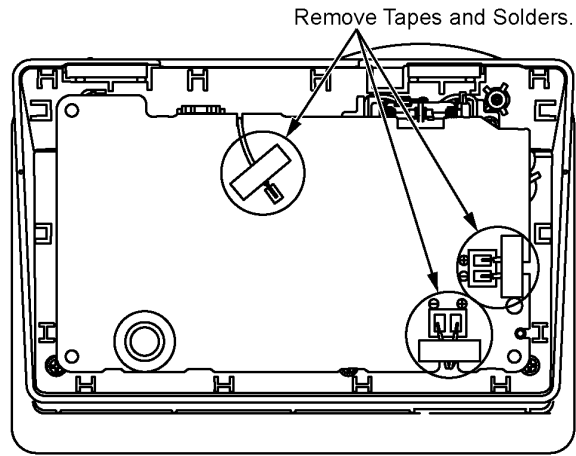

Fig. 2

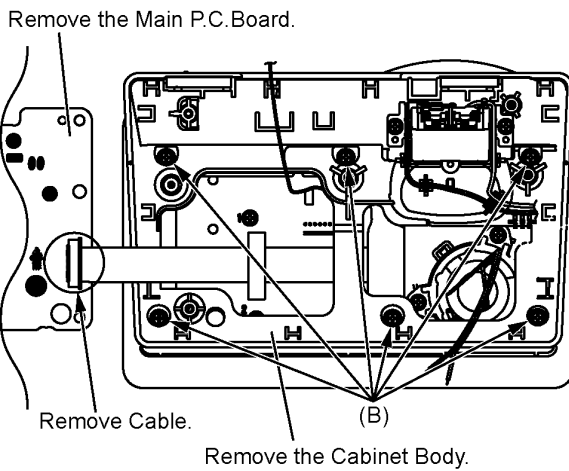

Fig. 3

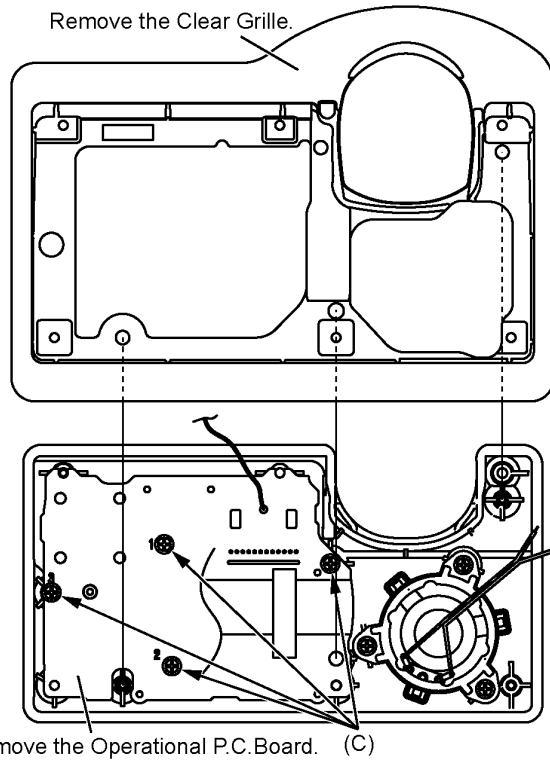

Fig. 4

Shown in Fig.-	To Remove	Remove
1	Cabinet Cover	Screws (2.6 × 14).....(A) × 5
2	Main P.C.Board	Tapes and Solders
3	Main P.C.Board	Cable
	Main P.C.Board	Main P.C.Board
4	Cabinet Body	Screws (2.6 × 14).....(B) × 6
	Operational P.C.Board	Clear Grille
		Screws (2.6 × 8).....(C) × 4
		Operational P.C.Board

5.2. Handset

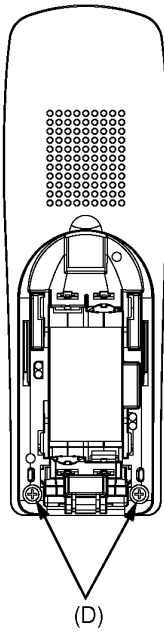

Fig. 5

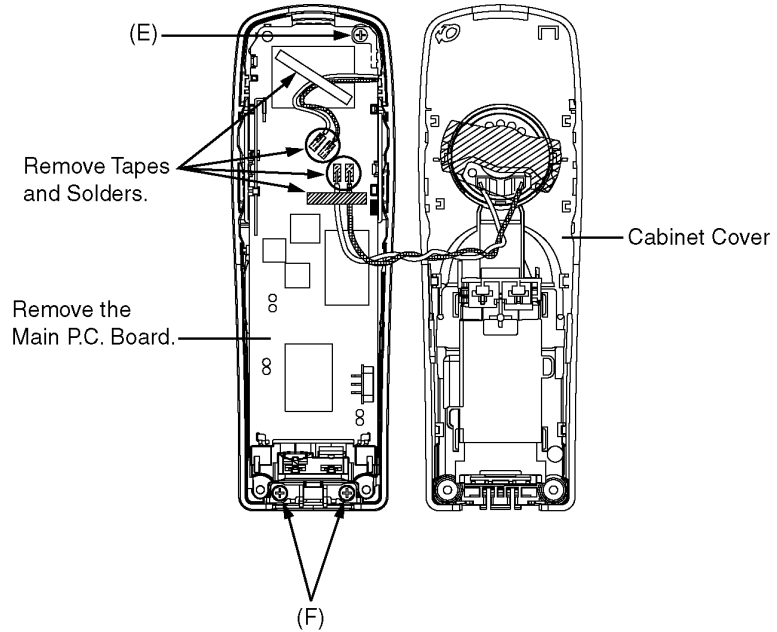
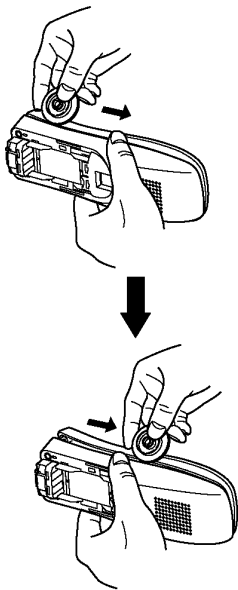
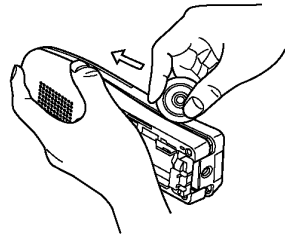

Fig. 7



Insert a JIG (PQDJ10006Y) between the Cabinet Body and the Cabinet Cover, then pull it along the gap to open the Cabinet.



Likewise, open the other side of the Cabinet.

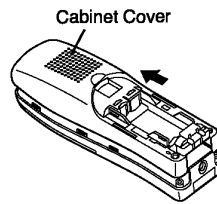

Remove the Cabinet Cover by pushing it upward.

Fig. 6

Shown in Fig.-	To Remove	Remove
5	Cabinet Cover	Screws (2 × 10).....(D) × 2
6		Follow the procedure.
7	Main P.C.Board	Screw (2 × 10).....(E) × 1
		Screws (2 × 10).....(F) × 2
		Tapes and Solders
		Main P.C.Board

5.3. Charger Unit

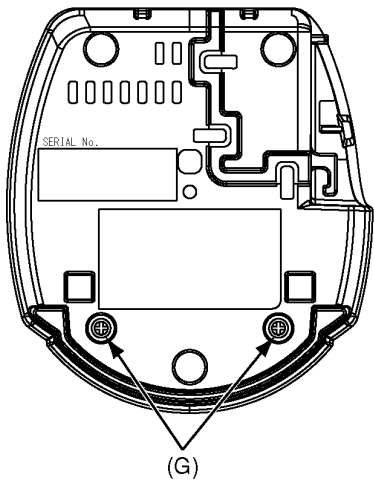

Fig. 8

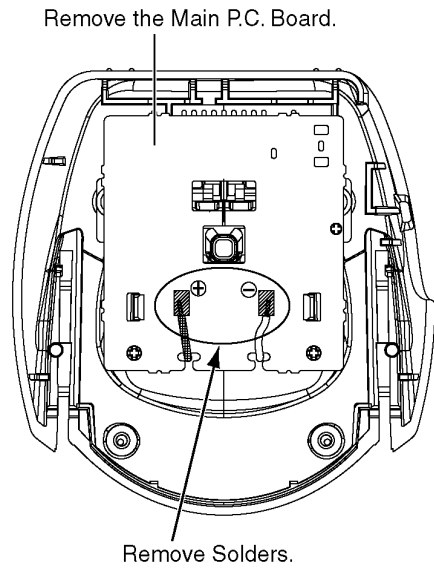

Fig. 9

Shown in Fig.-	To Remove	Remove
8	Cabinet Cover	Screws (2.6 × 10).....(G) × 2
9	Main P.C.Board	Solders
		Main P.C.Board

6 ASSEMBLY INSTRUCTIONS

6.1. Fix the LCD to the Main P.C.Board (Handset)

① Attach LCD to P.C.B.

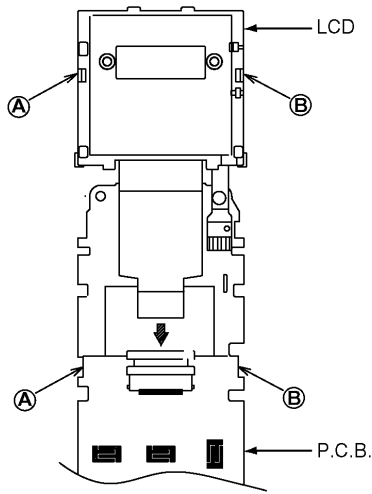

② Locate the flat Cable as shown.

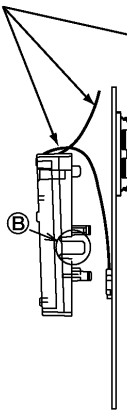

③ After attaching LCD, lock it with part A and B.

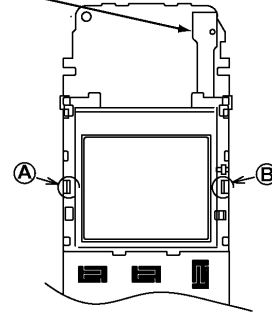

④ Double Sided Tape
Peel off the Separator.

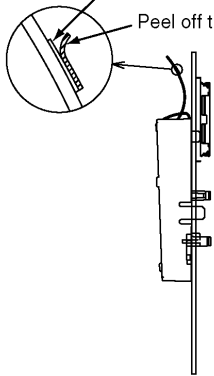

⑤

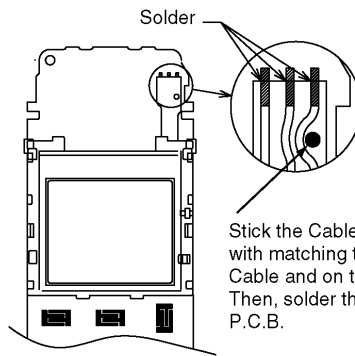

Stick the Cable to the P.C.B. with matching the holes on the Cable and on the P.C.B. Then, solder the Cable to the P.C.B.

<Details of step ① above>

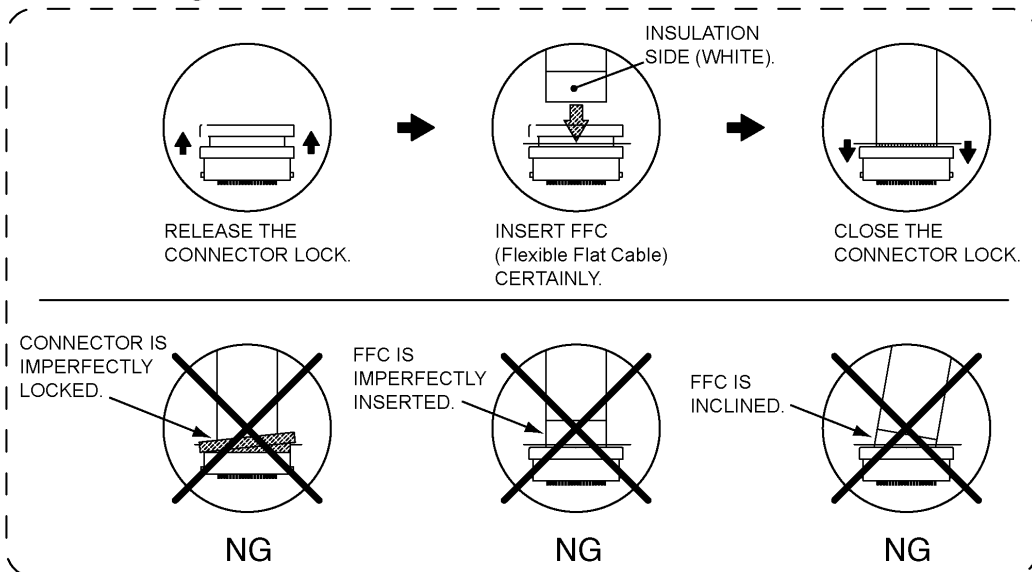

7 TROUBLESHOOTING FLOWCHART

Flow Chart

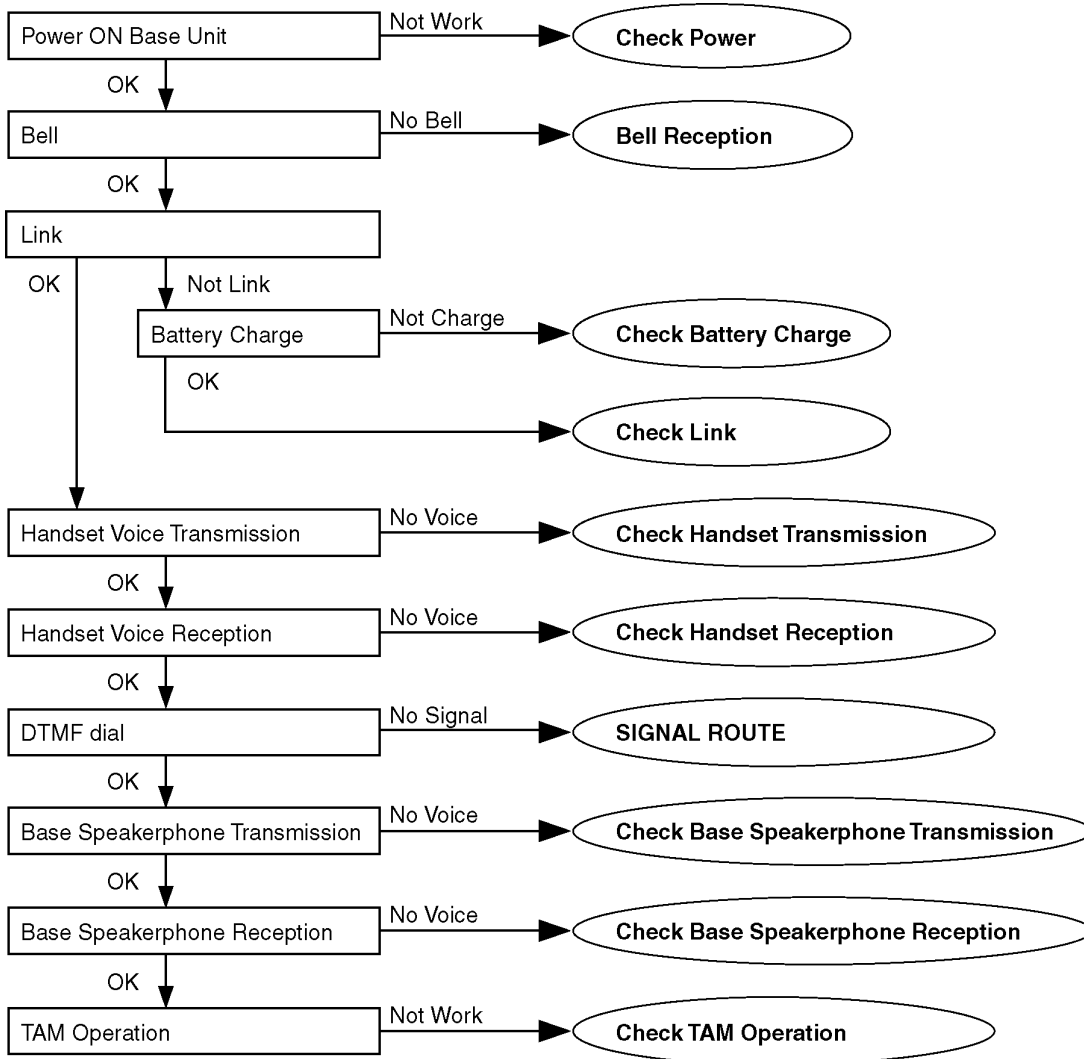

Cross Reference:

- Check Power (P.19)
- Bell Reception (P.26)
- Check Battery Charge (P.20)
- Check Link (P.21)
- Check Handset Transmission (P.25)
- Check Handset Reception (P.25)
- SIGNAL ROUTE (P.51)
- Check Base Speakerphone Transmission (P.25)
- Check Base Speakerphone Reception (P.25)
- Check TAM Operation (P.26)

7.1. Check Power

7.1.1. Base Unit

Is the AC Adaptor inserted into AC outlet? (Check AC Adaptor's specification.)

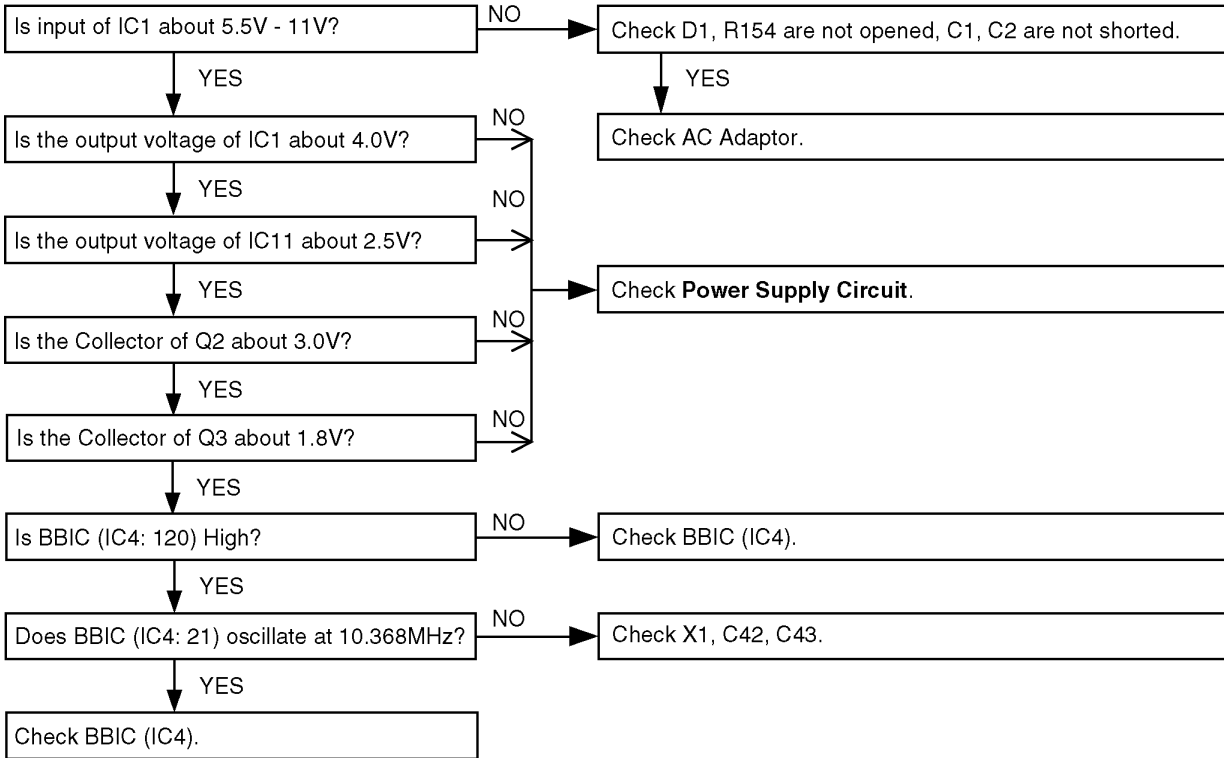

Cross Reference:

Power Supply Circuit (P.46)

7.1.2. Handset

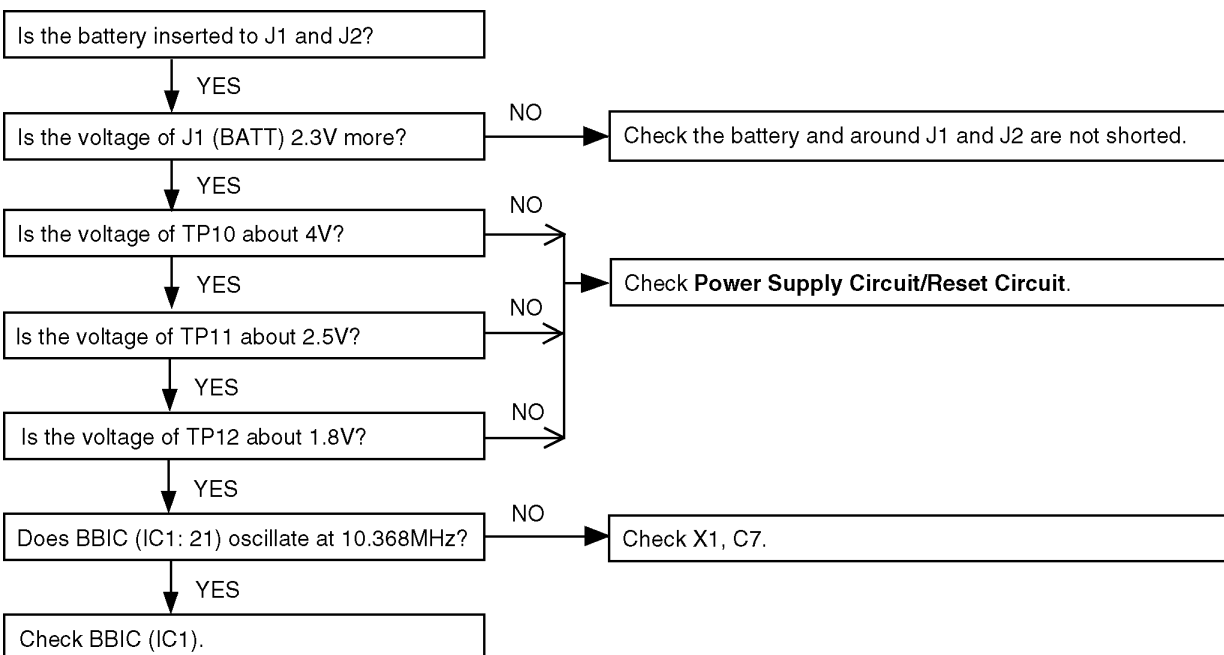

Cross Reference:

Power Supply Circuit/Reset Circuit (P.49)

7.2. Check Battery Charge

7.2.1. Base Unit

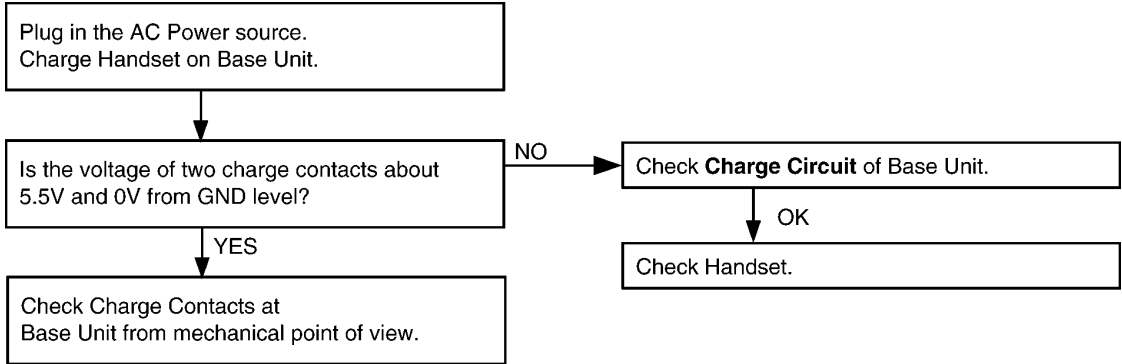

Cross Reference:

Charge Circuit (P.49)

7.2.2. Handset

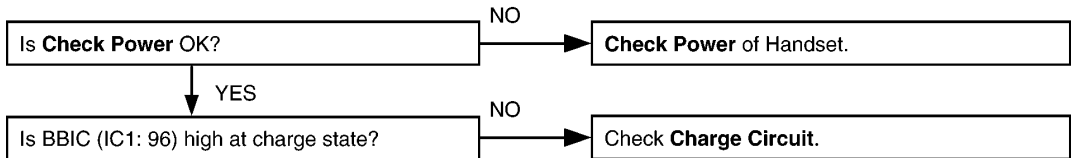

Cross Reference:

Check Power (P.19)

Charge Circuit (P.49)

7.2.3. Charger Unit

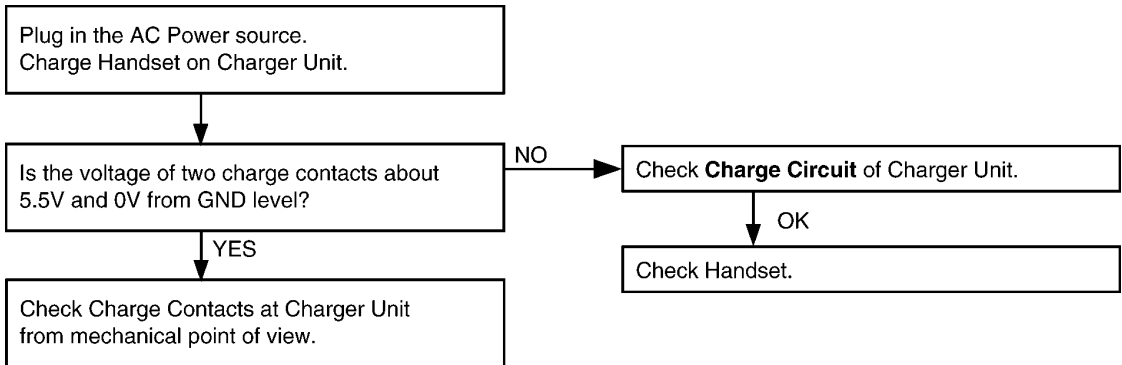

Cross Reference:

Charge Circuit (P.49)

7.3. Check Link

7.3.1. Base Unit

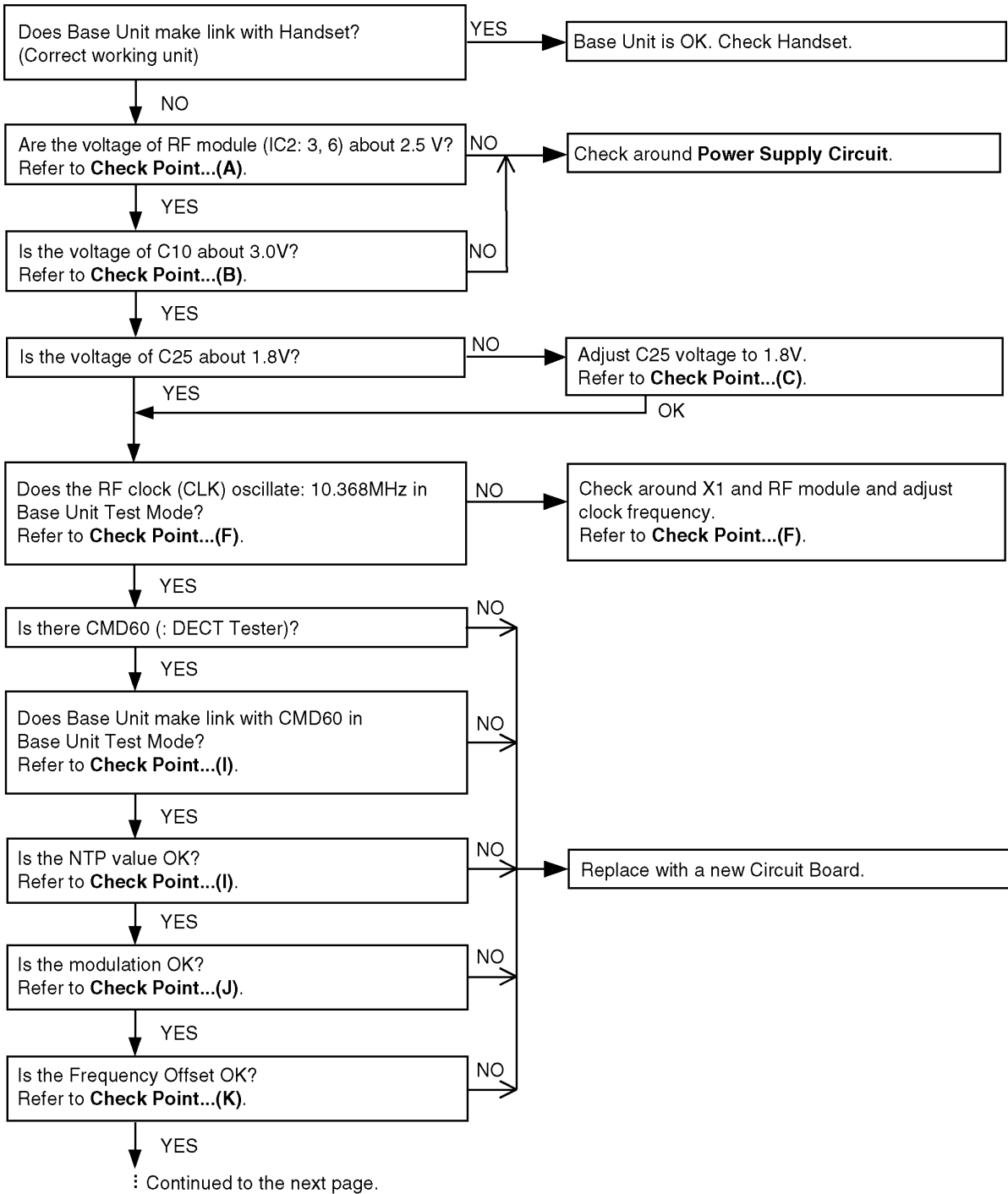

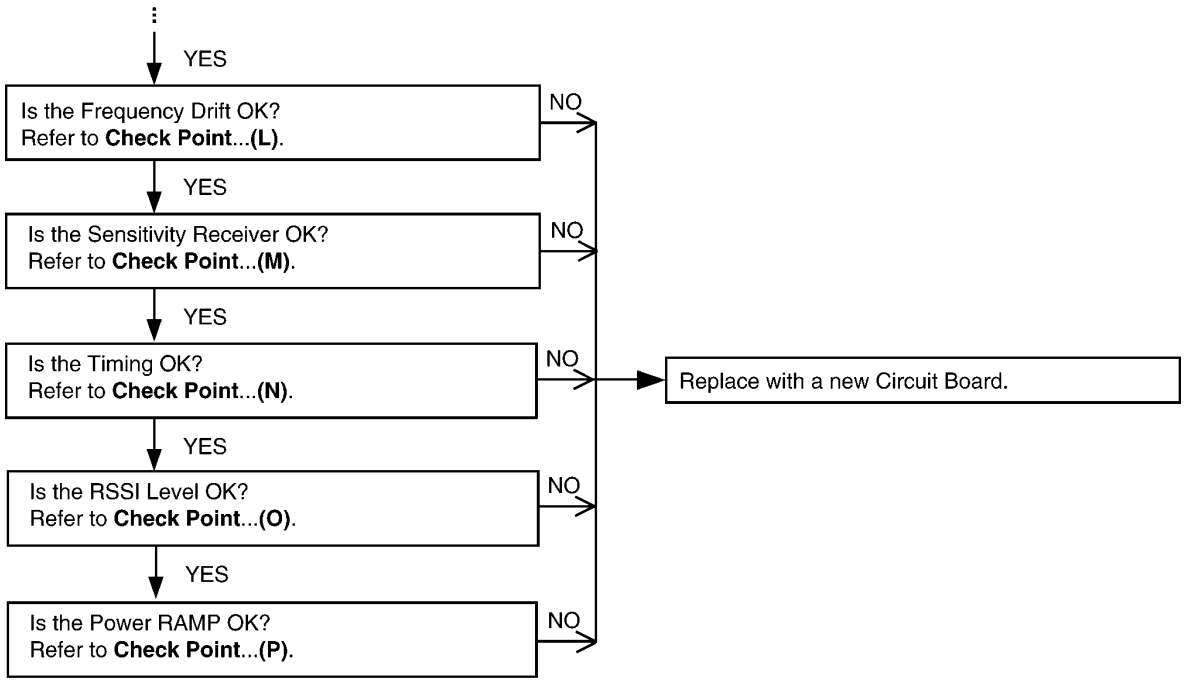

Cross Reference:

Power Supply Circuit (P.46)

Check Point (Base Unit) (P.27)

7.3.2. Handset

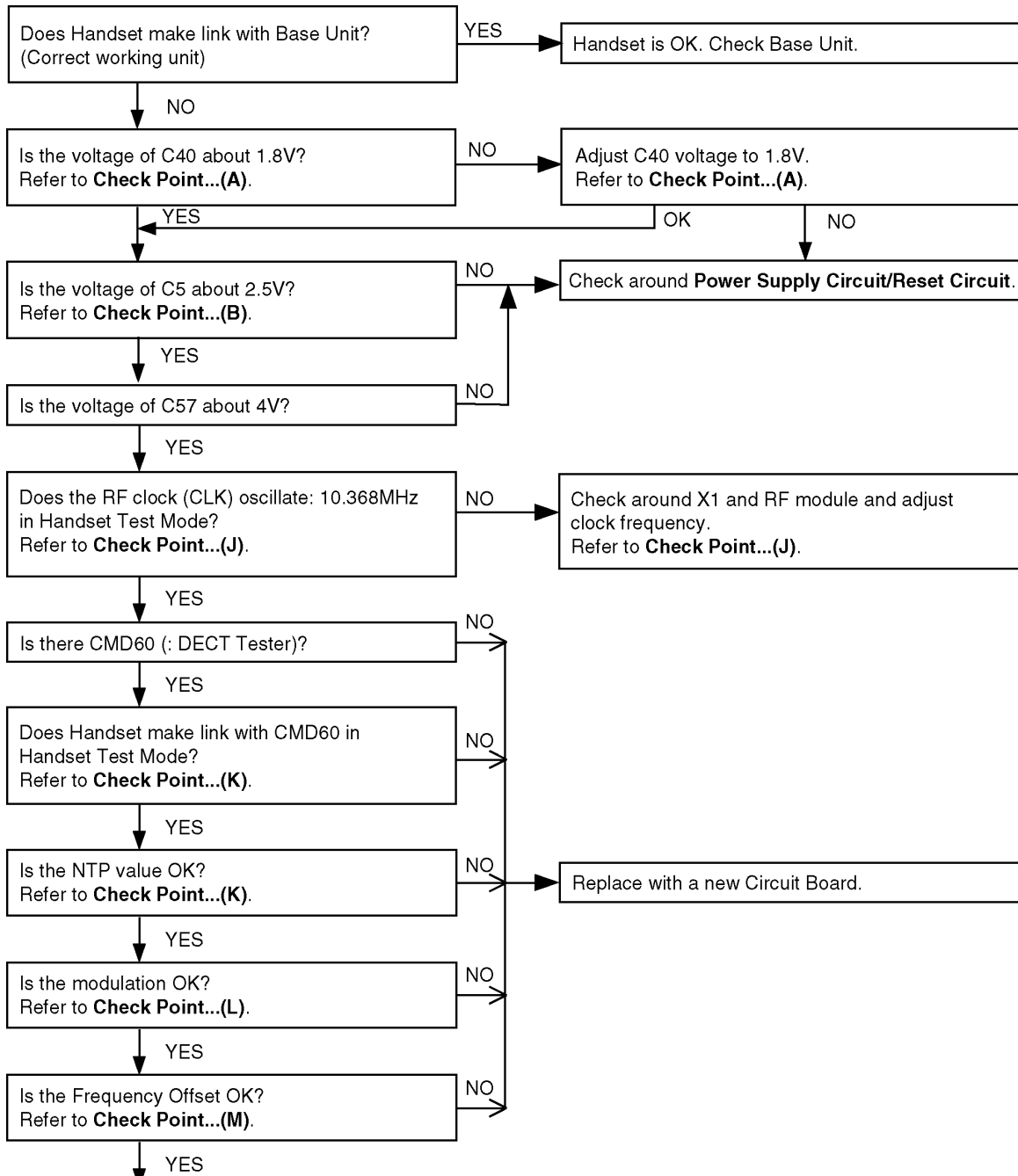

⋮ Continued to the next page.

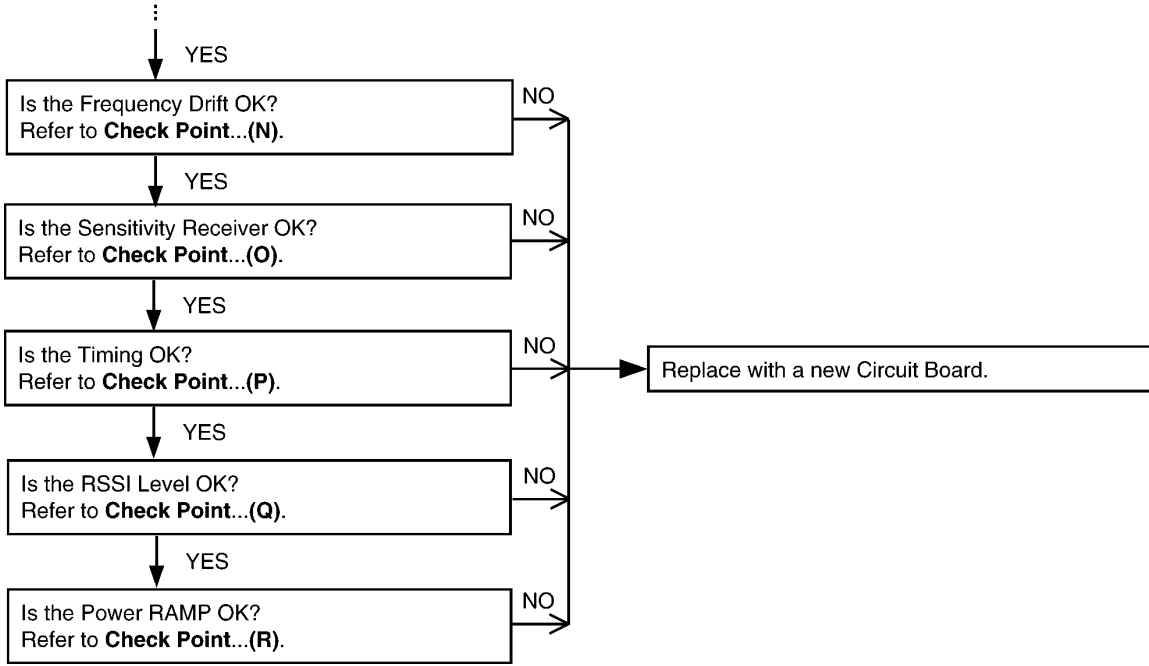

Cross Reference:

Power Supply Circuit/Reset Circuit (P.49)

Check Point (Handset) (P.35)

7.4. Check Handset Transmission



Cross Reference:
SIGNAL ROUTE (P.51)

7.5. Check Handset Reception

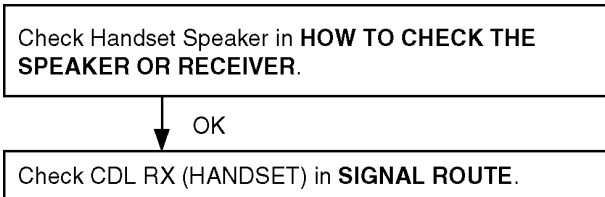

Cross Reference:
HOW TO CHECK THE SPEAKER OR RECEIVER (P.43).
SIGNAL ROUTE (P.51)

7.6. Check Caller ID



Cross Reference:
SIGNAL ROUTE (P.51)

7.7. Check Base Speakerphone Transmission

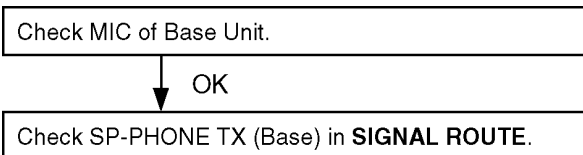

Cross Reference:
SIGNAL ROUTE (P.51)

7.8. Check Base Speakerphone Reception

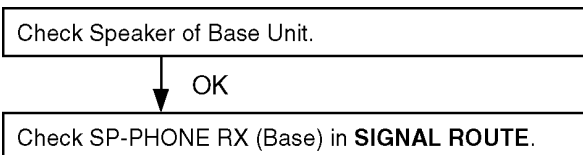

Cross Reference:
SIGNAL ROUTE (P.51)

7.9. Bell Reception

7.9.1. Base Unit

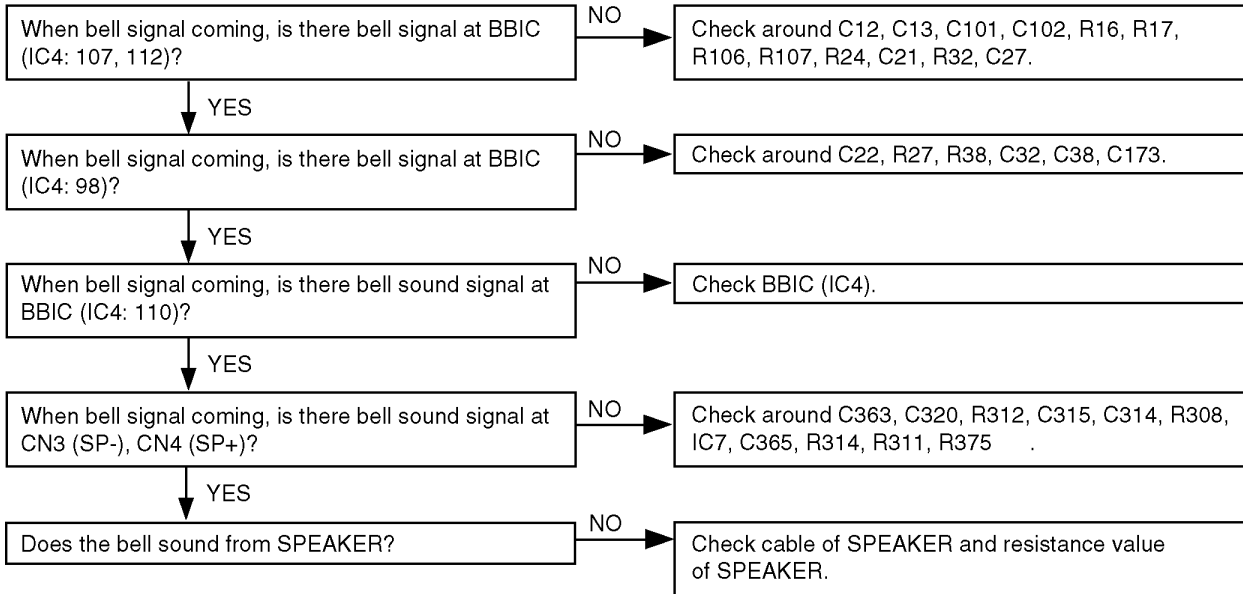

7.9.2. Handset

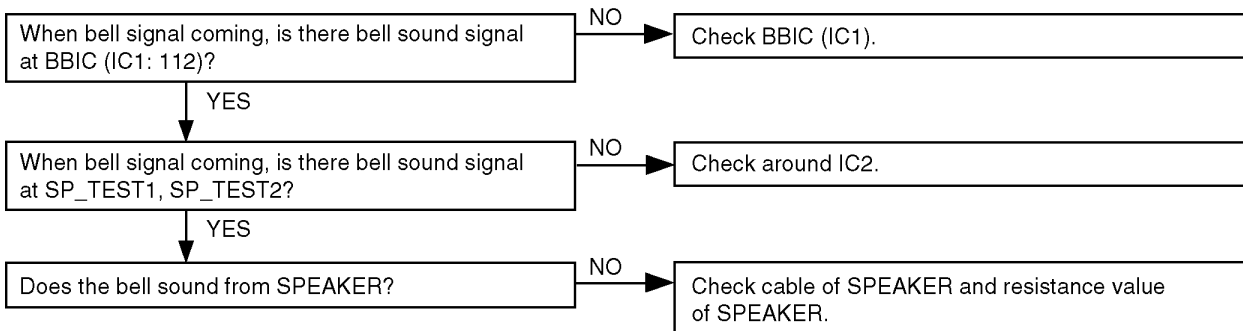

Cross Reference:

Telephone Line Interface (P.47)

Check Link (P.21)

HOW TO CHECK THE SPEAKER OR RECEIVER (P.43)

7.10. Check TAM Operation

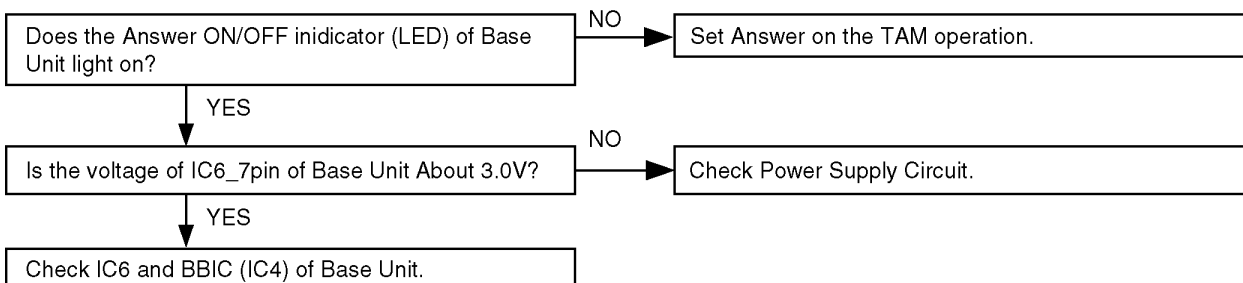

Cross Reference:

Power Supply Circuit (P.46)

8 TROUBLESHOOTING BY SYMPTOM (BASE UNIT AND CHARGER UNIT)

If your unit has below symptoms, follow the instructions in remedy column. Remedies depend on whether you have DECT tester (*1) or not.

Symptom	Remedy (*2)	
	You don't have DECT Tester.	You have DECT Tester. (Model Number : CMD60)
You cannot dial.	Check item (A)-(G).	Check item (A)-(G), (I)-(O).
You cannot hear the caller's voice.	Check item (A)-(F).	Check item (A)-(F), (I)-(L), (N).
You cannot use handset a little away from base unit even if the handset is within range of the base unit.	-	Check item (I), (M).
The acoustic transmission level is high or low.	Check item (Q).	Check item (Q).
The acoustic reception level is high or low.	Check item (Q).	Check item (Q).
The unit does not link.	Check item (A)-(H).	Check item (A)-(P).
The transmission level of base speakerphone is high or low.	Check item (R).	Check item (R).
The reception level of base speakerphone is high or low.	Check item (R).	Check item (R).
The unit cannot charge.	Check item (S).	Check item (S).
TAM does not work.	Check item (T).	Check item (T).

Note:

(*1): A general repair is possible even if you don't have the DECT tester because it is for confirming the levels, such as Acoustic level in detail.

(*2): Refer to **Check Point (Base Unit)** (P.27)

8.1. Check Point (Base Unit)

Please follow the items below when BBIC or EEPROM or FLASH ROM is replaced.

Note:

After the measuring, sock up the solder of TP.

*: **PC Setting** (P.39) is required beforehand.

The connections of adjustment equipments are as shown in **Adjustment Standard (Base Unit)** (P.33).

	Items	Check Point	Procedure	Check or Replace Parts				
(A)	2.5V Supply Confirmation	VDD4	1. Confirm that the voltage between test point VDD4 and GND is $2.5V \pm 0.2V$.	D1, IC11, C4, C7, R10, R11, C30, C26, C28, L12				
(B)	3.0V Supply Confirmation	VDD3	1. Confirm that the voltage between test point VDD3 and GND is $3.0V \pm 0.2V$.	C2, IC1, C3, C8, Q2, R5, C10, R18, R19, C11				
(C)*	1.8V Supply Confirmation	VDD5	1. Confirm that the voltage between test point VDD5 and GND is $1.8V \pm 0.1V$.	Q3, R6, C25, D7, D8				
(D)*	BBIC Confirmation	-	1. BBIC Confirmation (Execute the command "getchk"). 2. Confirm the returned checksum value. Connection of checksum value and program number is shown below. <table border="1" style="margin-left: auto; margin-right: auto;"> <tr> <td>checksum value</td> <td>program number</td> </tr> <tr> <td>ex.) 5003</td> <td>D601ZC</td> </tr> </table>	checksum value	program number	ex.) 5003	D601ZC	IC4, X1, C42, C43, R40, C81, C82, C84
checksum value	program number							
ex.) 5003	D601ZC							

	Items	Check Point	Procedure	Check or Replace Parts
(E)*	EEP-ROM Confirmation	-	1. EEPROM Confirmation (Execute the command "ChkTCD240XXrevYY"). XX: country code YY: revision number 2. Confirm the returned checksum value. Note: "XX", "YY", and "checksum" vary depending on the country version. You can find them in the batch file, PQZZ- mentioned in JIG and PC (P.32) .	IC3, C53, R56, R57, C57, Q6, Q7, R64, R65, R35
(F)*	BBIC Clock Adjustment	CLK	1. Input Command "rdeeprom 00 01 01", then you can confirm the current value. 2. Adjust the frequency of CLK executing the command "setfreq xx (where xx is the value)" so that the reading of the frequency counter is 10.368000MHz \pm 10Hz.	IC2, IC4, R137, R125, C153, X1, C42, C43
(G)*	Hookswitch Check with DC Characteristics	-	1. Connect CN1 (Telephone Socket) to Tel-simulator which is connected with 600 Ω . 2. Set line voltage to 48V and line current to 40mA at off-hook condition of normal telephone. 3. Execute the command "hookoff" 4. Confirm that the line current is 40mA \pm 5mA. 5. Execute the command "hookon". 6. Confirm that the line current is less than + 0.8mA.	CN1, L6, L7, Q4, R23, R25, Q5, R26, R28, IC4, D3
(H)*	DTMF Generator Check	-	1. Connect CN1 (Telephone Socket) to DTMF tester. 2. Execute the command "hookoff" and "dtmf_hi". 3. Confirm that the high frequency (1477Hz) is -3 ± 2 dBm. 4. Execute the command "dtmf_lo". 5. Confirm that the low frequency (852Hz) is -6 ± 2 dBm.	IC4, R63, R39, C41, R49, C46, C47, R42, R43, R44, R45, R46, R47, R48, C108, C109, C40, C36, Q8, D4
(I)*	Transmitted Power Confirmation	-	Remove L4 before starting step from 1 to 7. 1. Configure the DECT tester (CMD60) as follows; <Setting> · Test mode: FP · Traffic Carrier: 5 · Traffic Slot: 4 · Mode: Loopback · PMID: 00000 · RF LEVEL = -70dBm. 2. Execute the command "testmode". 3. Execute the command "sendchar dmv 2 2". 4. Check that "Signalling Status" has been set to "Locked", then press "ACCEPT RFPI". 5. Initiate connection from Dect tester ("set up connect") 6. Execute the command "ANT1". 7. Confirm that the NTP value at ANT is 20dBm ~ 25dBm.	IC2, IC4, R137, R125, C153, L8, L5, L10, L9, C140, C141, DA1, C142, C143, C144, L3, L4, R118, R119, L12, C30, IC11, R10, R11, C28, C26, C147, C151, C157, R123, C158, R128, R129, C159, C160, R131, R130, C161, C162, R132, C164, C136, R134, R117, R127, C156, C154, C155, R135, R136
(J)	Modulation Check and Adjustment	-	Follow steps 1 to 6 of (I). 7. Confirm that the B-Field Modulation is $-350 \sim -400/+320 \sim +370$ kHz/div using data type Fig31. 8. Adjust the B-Field Modulation if required. (Execute the command "readmod" and "wrtmod xx", where xx is the value.)	IC2, IC4, R137, R125, C153, L8, L5, L10, L9, C140, C141, DA1, C142, C143, C144, L3, L4, R118, R119, L12, C30, IC11, R10, R11, C28, C26, C147, C151, C157, R123, C158, R128, R129, C159, C160, R131, R130, C161, C162, R132, C164, C136, R134, R117, R127, C156, C154, C155, R135, R136

	Items	Check Point	Procedure	Check or Replace Parts
(K)	Frequency Offset Check	-	Follow steps 1 to 6 of (I). 7. Confirm that the frequency offset is $< \pm 45\text{kHz}$.	IC2, IC4, R137, R125, C153, L8, L5, L10, L9, C140, C141, DA1, C142, C143, C144, L3, L4, R118, R119, L12, C30, IC11, R10, R11, C28, C26, C147, C151, C157, R123, C158, R128, R129, C159, C160, R131, R130, C161, C162, R132, C164, C136, R134, R117, R127, C156, C154, C155, R135, R136
(L)	Frequency Dirft Confirmation	-	Follow steps 1 to 6 of (I). 7. Confirm that the frequency drift is $< \pm 30\text{kHz/ms}$.	IC2, IC4, R137, R125, C153, L8, L5, L10, L9, C140, C141, DA1, C142, C143, C144, L3, L4, R118, R119, L12, C30, IC11, R10, R11, C28, C26, C147, C151, C157, R123, C158, R128, R129, C159, C160, R131, R130, C161, C162, R132, C164, C136, R134, R117, R127, C156, C154, C155, R135, R136
(M)	Sensitivity Receiver Confirmation	-	Follow steps 1 to 6 of (I). 7. Set DECT tester power to -88dBm . 8. Confirm that the BER is $< 1000\text{ppm}$.	IC2, IC4, R137, R125, C153, L8, L5, L10, L9, C140, C141, DA1, C142, C143, C144, L3, L4, R118, R119, L12, C30, IC11, R10, R11, C28, C26, C147, C151, C157, R123, C158, R128, R129, C159, C160, R131, R130, C161, C162, R132, C164, C136, R134, R117, R127, C156, C154, C155, R135, R136

	Items	Check Point	Procedure	Check or Replace Parts
(N)	Timing Confirmation	-	Follow steps 1 to 6 of (I). 7. Confirm that the Timing accuracy is $< \pm 2.0\text{ppm}$.	IC2, IC4, R137, R125, C153, L8, L5, L10, L9, C140, C141, DA1, C142, C143, C144, L3, L4, R118, R119, L12, C30, IC11, R10, R11, C28, C26, C147, C151, C157, R123, C158, R128, R129, C159, C160, R131, R130, C161, C162, R132, C164, C136, R134, R117, R127, C156, C154, C155, R135, R136
(O)*	RSSI Level Confirmation	-	Follow steps 1 to 6 of (I). 7. Execute the command "readrssi". 8. Confirm that the returned value is $0 \times 22 \pm A$ (hex).	IC2, IC4, R137, R125, C153, L8, L5, L10, L9, C140, C141, DA1, C142, C143, C144, L3, L4, R118, R119, L12, C30, IC11, R10, R11, C28, C26, C147, C151, C157, R123, C158, R128, R129, C159, C160, R131, R130, C161, C162, R132, C164, C136, R134, R117, R127, C156, C154, C155, R135, R136
(P)	Power RAMP Confirmation	-	Follow steps 1 to 6 of (I). 7. Confirm that Power RAMP is matching.	IC2, IC4, R137, R125, C153, L8, L5, L10, L9, C140, C141, DA1, C142, C143, C144, L3, L4, R118, R119, L12, C30, IC11, R10, R11, C28, C26, C147, C151, C157, R123, C158, R128, R129, C159, C160, R131, R130, C161, C162, R132, C164, C136, R134, R117, R127, C156, C154, C155, R135, R136

	Items	Check Point	Procedure	Check or Replace Parts
(Q)*	Audio Check	-	<ol style="list-style-type: none"> 1. Link with Handset. 2. Input -45dBm/1kHz to MIC of Handset. Measure the Level at Line I/F and distortion level. 3. Confirm that the level is -9.5dBm ± 2dBm and that the distortion level is < 5% at TEL Line (600Ω Load). 4. Input -20dBm/1kHz to Line I/F. Measure the level at Receiver of Handset and distortion level (*Receive volume set to second position from minimum). 5. Confirm that the level is -21dBm ± 2dBm and that the distortion level is < 5% at Receiver (Volume Middle, 150Ω Load). 	IC4, CN1, SA1, L6, L7, D3, Q4, Q5, R23, R25, R26, R28, R63, R39, C41, R49, C46, C47, R42, R43, R44, R45, R46, R47, R48, C108, C109, C40, C36, Q8, C24, R60, R62
(R)	SP-Phone Audio Check	-	<ol style="list-style-type: none"> 1. Press SP-PHONE button. 2. Press MUTE button. 3. Input -30Bm/1kHz to Line interface. (SP-Phone volume Maximum.) 4. Measure the output level and distortion level at base speaker. 5. Confirm that the level is -3dBm ±5dBm and that the distortion level is < 5%. 6. Press MUTE button. 7. Input -45dBm/1kHz to SP-Phone MIC. (TP1-TP2) 8. Measure the output level and distortion level at line interface. 9. Confirm that the level is -0dBm ±5dBm and that the distortion level is < 5%. 	IC4, IC7, D311, R375, C312, C313, C314, C315, C316, C317, C318, C319, R308, R311, R312, R314, C320, C367, D301, R301, R302, R303, R304, R305, R307, C301, C302, C303, C304, C305, R306
(S)	Charging Check	-	<ol style="list-style-type: none"> 1. Connect Charge Contact 12Ω/2W resistor between charge+ and charge-. 2. Measure and confirm voltage across the resistor is 2.85V ± 0.2V. 	R2, R3, R4, D6, C180, C181, C182, D361, Q361, Q362, C361, C362, R361, R362, R363, C322, L13, L14
(T)	TAM Operation Confirmation	-	<ol style="list-style-type: none"> 1. TAM Confirmation (Execute the command "sendchar_VPI") 2. Confirm the returned Value (Value is "D597RQ"). 	IC6, R91, R92, C86, R33, R34

8.2. The Setting Method of JIG (Base Unit)

8.2.1. Preparation

8.2.1.1. Equipment Required

- DECT tester: Rohde & Schwarz, CMD 60 is recommended.
- Frequency counter: it must be precise to be able to measure 1Hz (precision; $\pm 4\text{ppm}$).
Hewlett Packard, 53131A is recommended.
- Digital multi-meter (DMM): it must be able to measure voltage and current.
- Oscilloscope

8.2.1.2. JIG and PC

- EEPROM serial JIG
JIG Cable: PQZZ1CD300E*
- PC which runs in DOS mode
- **Batch file CD-ROM** for setting: PQZZTCD346UA

Note:

*: If you have the JIG Cable for TCD500 series (PQZZ1CD505E), change the following values of resistance. Then you can use it as a JIG Cable for both TCD300 and TCD500 series. (It is an upper compatible JIG Cable.)

Resistor	Old value (k Ω)	New value (k Ω)
R2	22	3.3
R3	22	3.3
R4	22	4.7
R7	4.7	10

8.2.2. PC Setting

8.2.2.1. Connections

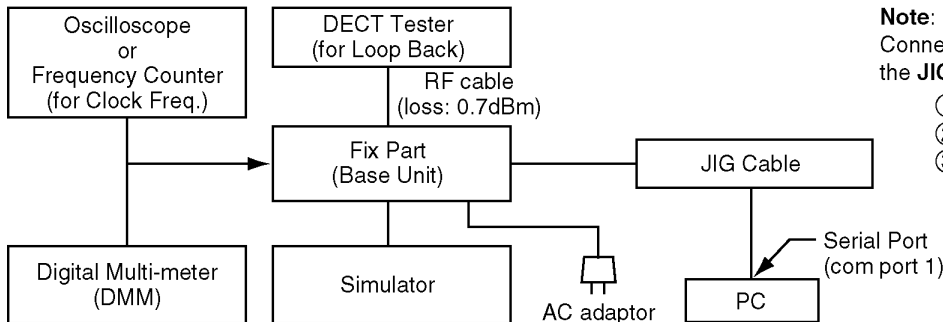

Note:

Connect the **Power Supply** and the **JIG Cable** in the following order.

- ① POWER SUPPLY ON
- ② JIG-CABLE GND
- ③ JIG-CABLE UTX/URX

8.2.2.2. PC Setting

1. Open a window of MS-DOS mode from the start-up menu.
2. Change a directory.
3. Type **"SET_COM=1"** from the keyboard (when COM port 1 is used for the connection).
4. Type "doskey".

Note:

See the table below for frequently used commands.

Command name	Function	Example
rdeeprom	Read the data of EEPROM	Type "rdeeprom 00 00 FF", and the data from address "00 00" to "FF" is read out.
readid	Read ID (RFPI)	Type "readid", and the registered ID is read out.
writeid	Write ID (RFPI)	Type "writeid 00 18 E0 0E 98", and the ID "0018 E0 0E 98" is written.
setfreq	Adjust Frequency of RFIC	Type "setfreq nn".
hookoff	Off-hook mode on Base	Type "hookoff".
hookon	On-hook mode on Base	Type "hookon".
getchk	Read checksum	Type "getchk".
wreeprom	Write the data of EEPROM	Type "wreeprom 01 23 45". "01 23" is address and "45" is data to be written.

8.3. Adjustment Standard (Base Unit)

When connecting the Simulator Equipments for checking, please refer to below.

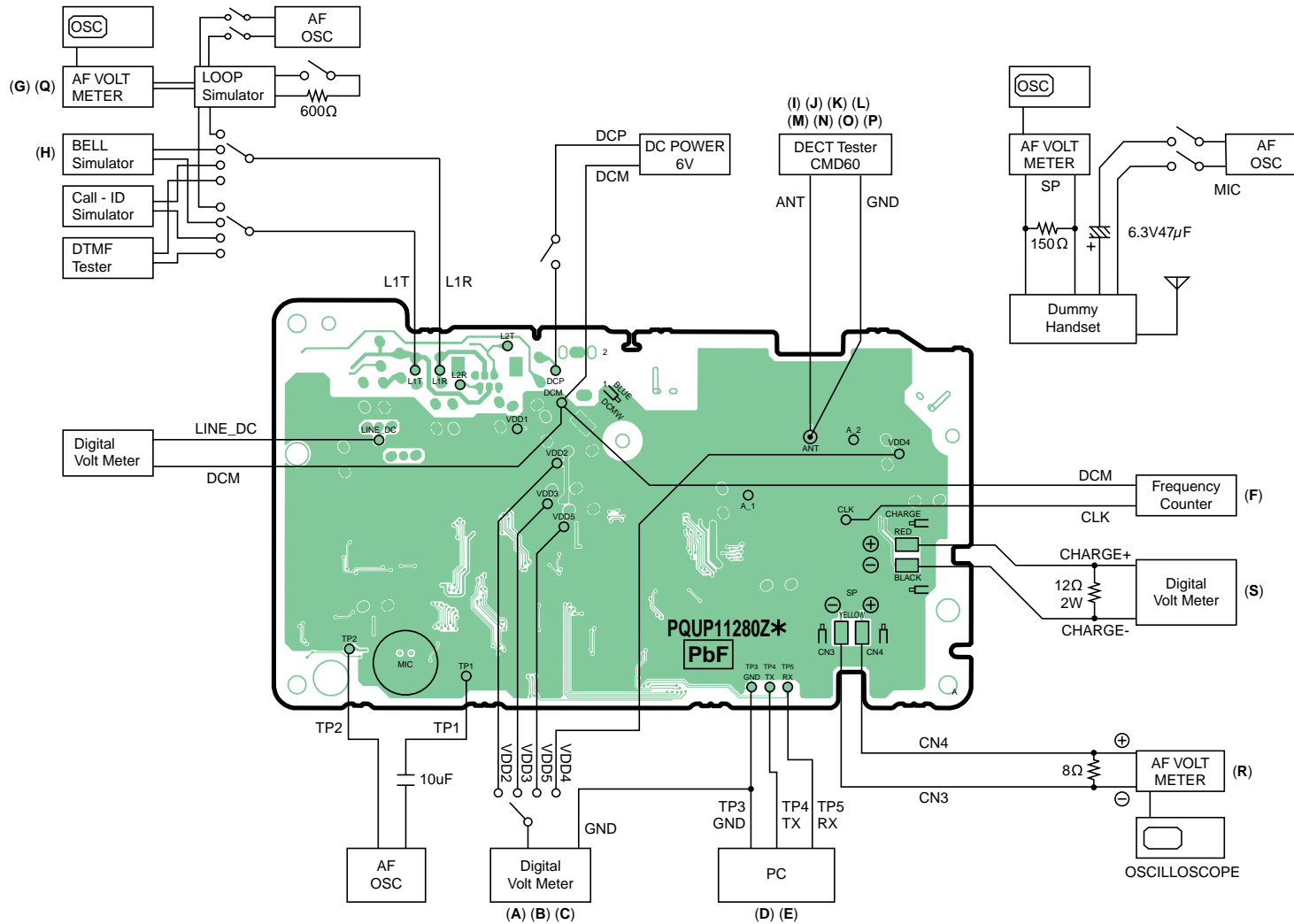

Note:

(A) - (S) is referred to **Check Point (Base Unit)** (P.27)

8.4. Check Point (Charger Unit)

	Items	Check Point	Procedure	Check or Replace Parts
(A)	Charging Check	-	1. Connect Charge Contact 12Ω/2W resistor between charge+ and charge-. 2. Measure and confirm voltage across the resistor is 2.85V ± 0.2V.	D11, R11, R12

Note:

After the measuring, sock up the solder of TP.

The connection of adjustment equipment is as shown in **Adjustment Standard (Charger Unit)** (P.34).

8.5. Adjustment Standard (Charger Unit)

When connecting the Simulator Equipments for checking, please refer to below.

8.5.1. Flow Solder Side View

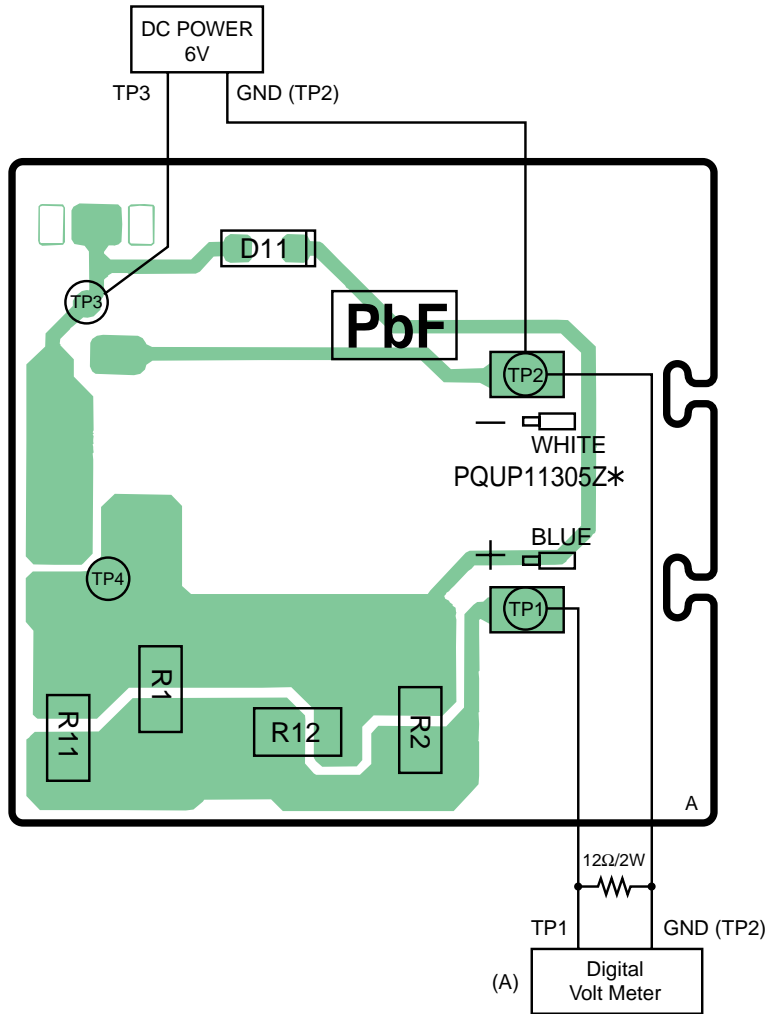

Note:

(A) is referred to **Check Point (Charger Unit)** (P.34)

9 TROUBLESHOOTING BY SYMPTOM (HANDSET)

If your unit has below symptoms, follow the instructions in remedy column. Remedies depend on whether you have DECT tester (*1) or not.

Symptom	Remedy (*2)	
	You don't have DECT Tester.	You have DECT Tester. (Model Number : CMD60)
Battery strength is not indicated correctly by Battery icon.	Check item (A)-(D), (H)-(I).	Check item (A)-(D), (H)-(I).
You cannot hear the caller's voice.	Check item (A)-(D), (J).	Check item (A)-(D), (J)-(M), (N), (P).
You cannot use handset a little away from base unit even if the handset is within range of the base unit.	-	Check item (K), (O).
Does not link between base unit and handset.	Check item (A)-(D), (J).	Check item (A)-(D), (J)-(Q).
The Audio level is high or low.	Check item (S).	Check item (S).
The SP-Phone level is high or low.	Check item (T).	Check item (T).

Note:

(*1): A general repair is possible even if you don't have the DECT tester because it is for confirming the levels, such as Acoustic level in detail.

(*2): Refer to **Check Point (Handset)** (P.35)

9.1. Check Point (Handset)

Please follow the items below when BBIC or EEPROM or FLASH ROM is replaced.

Note:

After the measuring, sock up the solder of TP.

*: **PC Setting** (P.39) is required beforehand.

The connections of adjustment equipments are as shown in **Adjustment Standard (Handset)** (P.40).

	Items	Check Point	Procedure	Check or Replace Parts				
(A)*	1.8V Supply Adjustment	TP12	1. Confirm that the voltage between test point TP12 and GND is $1.8V \pm 0.02V$. 2. Execute the command "bandgap", then check the current value. 3. Adjust the 1.8V voltage of TP12 executing command "bandgap XX"(XX is the value).	IC1, Q2, C40, R4				
(B)	DC/DC Supply Confirmation	TP10	1. Confirm that the voltage between test point TP10 and GND is $2.97V \pm 0.3V$ (Backlight is OFF)/ $4.40V \pm 0.3V$ (Backlight is ON).	IC1, F1, C1, C3, C57, C74, R1, R2, R3, Q1, D1, L1, R57				
(C)	2.5V Supply Confirmation	TP11	1. Confirm that the voltage between test point TP11 and GND is $2.5V \pm 0.1V$.	IC1, Q3, C4, C5, R9, R10, R11				
(D)*	BBIC Confirmation	-	1. BBIC Confirmation (Execute the command "getchk"). 2. Confirm the returned checksum value. Connection of checksum value and program number is shown below. ex.) <table border="1" style="display: inline-table; vertical-align: middle;"> <tr> <td>checksum value</td> <td>program number</td> </tr> <tr> <td>A676</td> <td>D552RP</td> </tr> </table>	checksum value	program number	A676	D552RP	IC1, X1, C7
checksum value	program number							
A676	D552RP							
(E)*	EEP-ROM Confirmation	-	1. EEP-ROM Confirmation (Execute the command "ChkTCA130XXrevYY"). XX: country code YY: revision number 2. Confirm the returned checksum value. Note: "XX", "YY", and "checksum" vary depending on the country version. You can find them in the batch file, PQZZ- mentioned in JIG and PC (P.39).	IC10, IC1, R39, R40				

	Items	Check Point	Procedure	Check or Replace Parts
(F)	Charge Control Check & Charge Current Monitor Check	-	1. Apply 6V between J3(+) and J4(-) with DC power supply and set current limit to 250mA. 2. Confirm that the current limit LED of DC power supply is ON/OFF. 3. Decrease current limit of DC power supply to 100mA. 4. Confirm that the current limit LED of DC power supply is stable. (Current limiter is ON.) (If charge control cannot be confirmed by this procedure, please use battery to handset power supply and try again.)	IC1, Q4, Q5, Q9, D6, L4, L5, C73, C74, R5, R6, R7, R72, F1
(G)*	Charge Detection (OFF) Check	-	1. Stop supplying 6V to CHARGE(+) and CHARGE(-). 2. Execute the command "Backloff" then "charge". 3. Confirm that the returned value is 0x00 (hex).	IC1, Q4, Q5, Q9 D6, D7, L4, L5, C73, C74, R5, R6, R7, R72, F1
(H)*	Battery Monitor Check	-	1. Apply 2.25V between BATT and GND. 2. Execute the command "readbatt". It assumes that the return value is XX. a) $1E \leq XX \leq 2C$: No need to adjust b) XX: 18 ~ 1D: Need to adjust XX: 2D ~ 32: Need to adjust Write AD value of 2.25V to EEPROM. ex) read data: XX = 1D, write data: YY = 1D read data: XX = 2D, write data: YY = 2D EEPROM = 0X0004(Low Voltage) write "YY", then EEPROM = 0X0005(No Voltage) write "YY - 1D" EEPROM = 0X000A(Low Voltage BL) write "YY - 06" No Voltage writing data limit is '00'. c) XX: 00 ~ 17: Reject XX: 33 ~ FF: Reject	IC1, F1, C74, C1 C3, R81, R24, R73, C9
(I)	Battery Low Confirmation	-	1. Apply 2.40V between BATTERY(+) and BATTERY(-). 2. Confirm that there is no flashing of Battery Icon. 3. Apply $2.25V \pm 0.08V$ between BATTERY(+) and BATTERY(-). 4. Confirm that there is flashing of Battery Icon.	IC1, F1, C74, C1 C3, R81, R24, R73, C9
(J)*	BBIC Clock Adjustment	CLK	1. Apply 2.6V between BATTERY(+) and BATTERY(-) with DC power. 2. Execute the command "contx". 3. Input Command "rdeeprom 00 01 01", then you can confirm the current value. 4. Adjust the frequency of CLK executing the command "setfreq xx (where xx is the value)" so that the reading of the frequency counter is $10.368000MHz \pm 10Hz$. Note: CLK is displayed only for a few seconds when executing the command "contx" after battery is inserted.	IC1, X1, CN6, C7, R127, C117
(K)*	Transmitted Power Confirmation	-	Remove the Antenna before starting step from 1 to 4. 1. Configure the DECT tester (CMD60) as follows; <Setting> · Test mode: PP · RFPI: 0102030405 · Traffic Carrier: 5 · Traffic Slot: 4 · Mode: Loopback · RF LEVEL = -70dBm 2. Execute the command "regcmd60 01 02 03 04 05". 3. Initiate connection from DECT tester. 4. Confirm that the NTP value at A201 is 20dBm ~ 25dBm.	IC1, IC3, R127, C117, C115, C119, C45, R121, C44, R123, C47, C46, R125, C48, C49, C50, C83, R75, C53, C51, R131, C54, C55, R129

	Items	Check Point	Procedure	Check or Replace Parts
(L)*	Modulation Check and Adjustment	-	Follow steps 1 to 3 of (K). 4. Confirm that the B-Field Modulation is -350 ~ -400/+320 ~ +370kHz/div using data type Fig 31. 5. Adjust the B-Field Modulation if required. (Execute the command "Readmod" and "wrtmod xx", where xx is the value.)	IC1, IC3, R127, C117, C115, C119, C45, R121, C44, R123, C47, C46, R125, C48, C49, C50, C83, R75, C53, C51, R131, C54, C55, R129
(M)	Frequency Offset Confirmation	-	Follow steps 1 to 3 of (K). 4. Confirm that the frequency Offset is $< \pm 45\text{kHz}$.	IC1, IC3, R127, C117, C115, C119, C45, R121, C44, R123, C47, C46, R125, C48, C49, C50, C83, R75, C53, C51, R131, C54, C55, R129
(N)	Frequency Drift Confirmation	-	Follow steps 1 to 3 of (K). 4. Confirm that the frequency Drift is $< \pm 30\text{kHz/ms}$.	IC1, IC3, R127, C117, C115, C119, C45, R121, C44, R123, C47, C46, R125, C48, C49, C50, C83, R75, C53, C51, R131, C54, C55, R129
(O)	Sensitivity Receiver Confirmation	-	Follow steps 1 to 3 of (K). 4. Set DECT tester power to -88dBm. 5. Confirm that the BER is $< 1000\text{ppm}$.	IC1, IC3, R127, C117, C115, C119, C45, R121, C44, R123, C47, C46, R125, C48, C49, C50, C83, R75, C53, C51, R131, C54, C55, R129
(P)	Timing Confirmation	-	Follow steps 1 to 3 of (K). 4. Confirm that the Timing accuracy is $< \pm 2.0\text{ppm}$.	IC1, IC3, R127, C117, C115, C119, C45, R121, C44, R123, C47, C46, R125, C48, C49, C50, C83, R75, C53, C51, R131, C54, C55, R129
(Q)*	RSSI Level Confirmation	-	Follow steps 1 to 3 of (K). 4. Set DECT tester power to -81dBm. 5. Execute the command "readrssi". 6. Confirm that the returned value is $0 \times 1B \pm 8$ (hex). 7. Set DECT tester power to -63dBm. 8. Execute the command "readrssi". 9. Confirm that the returned value is $0 \times 23 \pm 8$ (hex).	IC1, IC3, R127, C117, C115, C119, C45, R121, C44, R123, C47, C46, R125, C48, C49, C50, C83, R75, C53, C51, R131, C54, C55, R129

	Items	Check Point	Procedure	Check or Replace Parts
(R)	Power RAMP Confirmation	-	Follow steps 1 to 3 of (K). 4. Confirm that Power RAMP is matching.	IC1, IC3, R127, C117, C115, C119, C45, R121, C44, R123, C47, C46, R125, C48, C49, C50, C83, R75, C53, C51, R131, C54, C55, R129
(S)	Audio Check and Confirmation	-	1. Link to BASE which is connected to Line Simulator. 2. Set line voltage to 48V and line current to 40mA. 3. Input -45dBm/1KHz to MIC and measure Line output level. 4. Confirm that the level is -9.5dBm ± 2dBm and that the distortion level is < 5% at TEL Line (600Ω Load). 5. Input -20dBm/1KHz to Line I/F and measure Receiving level at REV1 and REV2. 6. Confirm that the level is -20.5dBm ± 2dBm and that the distortion level is < 5% at Receiver. (vol = 2)	IC1, C37, C68, C91, R25, R26, C20, C12, C14, C90, C87, C89, R29, R37, R38, C10, C17, D4, D5
(T)	SP-Phone Audio Check and Confirmation	-	1. Link to Base which is connected to Line Simulator. 2. Set line voltage to 48V and line current to 40mA. 3. Set the handset off-hook using SP-Phone key. 4. Input -20dBm/1KHz to Line I/F and measure Receiving level at SP1 and SP2. 5. Confirm that the level is -7dBm ± 2dBm and that the distortion level is < 5%. (vol = 3)	IC1, IC2, C37, C68, C68, C91, R25, R26, C20, C12, C14, C90, C87, C89, R29, R37, R38, C10, C17, C92, R80, C13, R35, C75, C86, C15, D8, C16, C77, C38, R36, R74, C80

9.2. Troubleshooting for Speakerphone (Handset)

When the customer's telephone line corresponds to the following conditions and transmission signal of SP-Phone is interrupted, performing the next set up to a cordless handset will improve it to some extent.

Conditions

1. When customer's line has less line loss.
ex.) The customer is using optical fiber, ISDN terminal adaptor, or PBX.
In this case, receiving signal is strong and it may affect transmission signal.
2. When the other party is talking from noisy place.
ex.) The other party is using cellular phone. The background noise is very loud.
In this case, the noise from the other party (i.e. surrounding noise) may affect transmission signal.

Setting Method

- Change the address of EEPROM (0x0144) from 0x00 to 0x01.

9.3. The Setting Method of JIG (Handset)

9.3.1. Preparation

9.3.1.1. Equipment Required

- DECT tester: Rohde & Schwarz, CMD 60 is recommended.
- Frequency counter: it must be precise to be able to measure 1Hz (precision; ±4ppm).
Hewlett Packard, 53131A is recommended.
- DC power: it must be able to output at least 1A current under 2.4V for Handset.
- Digital multi-meter (DMM): it must be able to measure voltage and current.
- Oscilloscope

9.3.1.2. JIG and PC

- EEPROM serial JIG
JIG Cable: PQZZ1CD300E*
- PC which runs in DOS mode.
- **Batch file CD-ROM** for setting: PQZZTCD346UA

Note:

*: If you have the JIG Cable for TCD500 series (PQZZ1CD505E), change the following values of resistance. Then you can use it as a JIG Cable for both TCD300 and TCD500 series. (It is an upper compatible JIG Cable.)

Resistor	Old value (kΩ)	New value (kΩ)
R2	22	3.3
R3	22	3.3
R4	22	4.7
R7	4.7	10

9.3.2. PC Setting

9.3.2.1. Connections

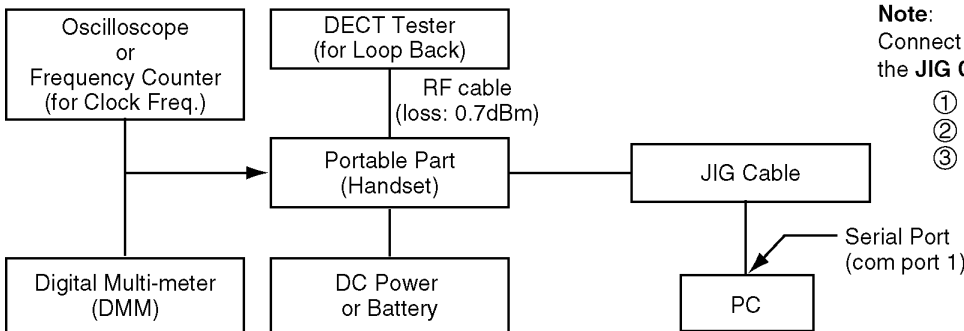

Note:

Connect the **Power Supply** and the **JIG Cable** in the following order.

- ① POWER SUPPLY ON
- ② JIG-CABLE GND
- ③ JIG-CABLE UTX/URX

9.3.2.2. PC Setting

1. Open a window of MS-DOS mode from the start-up menu.
2. Change a directory.
3. Type **"SET_COM=1"** from the keyboard (when COM port 1 is used for the connection).
4. Type "doskey".

Note:

See the table below for frequently used commands.

Command name	Function	Example
rdeeprom	Read the data of EEPROM	Type "rdeeprom 00 00 FF", and the data from address "00 00" to "FF" is read out.
readid	Read ID (RFPI)	Type "readid", and the registered ID is read out.
writeid	Write ID (RFPI)	Type "writeid 00 18 E0 0E 98", and the ID "0018 E0 0E 98" is written.
setfreq	Adjust Frequency of RFIC	Type "setfreq nn".
getchk	Read checksum	Type "getchk".
wreeprom	Write the data of EEPROM	Type "wreeprom 01 23 45". "01 23" is address and "45" is data to be written.

9.4. Adjustment Standard (Handset)

When connecting the Simulator Equipments for checking, please refer to below.

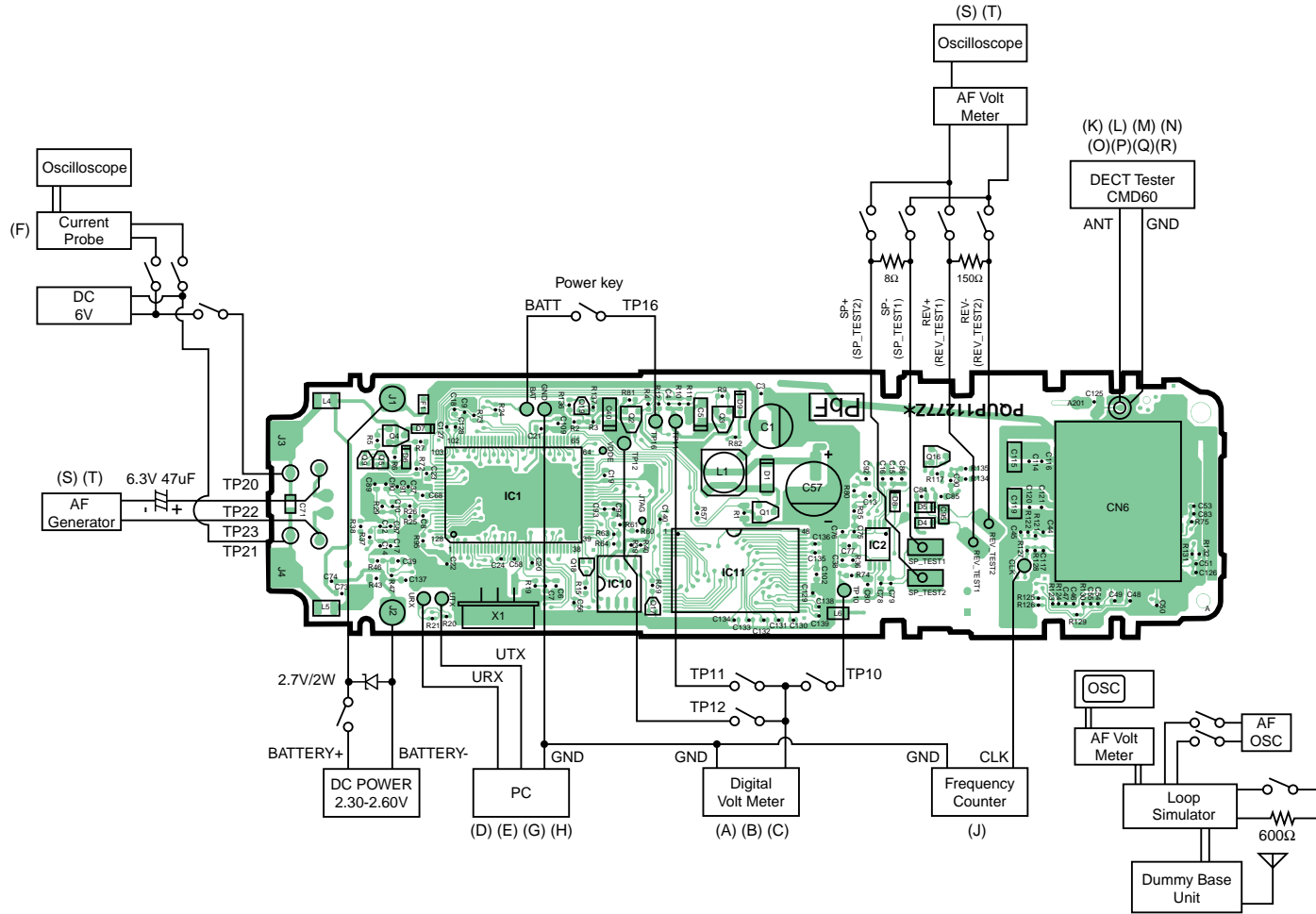

Note:

(A) - (T) is referred to **Check Point (Handset)** (P.35)

10 THINGS TO DO AFTER REPLACING IC

Cautions:

Since this page is common to each country, it may not apply to some models in your country. The contents below are the minimum adjustments required for operation.

10.1. Base Unit

IC		Necessary Adjustment
BBIC	Programs for Voice processing, interface for RF and EEPROM	1. Default batch file: Execute the command "default". 2. Country version batch file: Execute the command "TCD240XXrevYY". (*1) 3. Clock adjustment: Refer to Check Point (F). (*2)
EEPROM	Adjustment parameter data (country version batch file, default batch file, etc.)	1. Change the address "0000" of EEPROM to "55". 2. Default batch file: Execute the command "default". 3. Country version batch file: Execute the command "TCD240XXrevYY". (*1) 4. Clock adjustment: Refer to Check Point (F). (*2)
FLASH 1	Voice prompt data (vary depending on country version)	No need to adjust.
FLASH 2	Program	No need to adjust.

Note:

(*1) XX: country code, YY: revision number

"XX" and "YY" vary depending on the country version. You can find them in the batch file, PQZZ- mentioned in **JIG and PC** (P.32).

(*2) Refer to **Check Point (Base Unit)** (P.27)

10.2. Handset

IC		Necessary Adjustment
BBIC	Programs for Voice processing, interface for RF and EEPROM	1. Default batch file: Execute the command "default". 2. Country version batch file: Execute the command "TCA130XXrevYY". (*3) 3. Clock adjustment: Refer to Check Point (J). (*4) 4. 1.8 V setting and battery low detection: Refer to Check Point (A), (H) and (I). (*4)
EEPROM	Adjustment parameter data (country version batch file, default batch file, etc.)	1. Change the address "0015" of EEPROM to "55". 2. Default batch file: Execute the command "default". 3. Country version batch file: Execute the command "TCA130XXrevYY". (*3) 4. Clock adjustment: Refer to Check Point (J). (*4) 5. 1.8 V setting and battery low detection: Refer to Check Point (A), (H) and (I). (*4)
FLASH 2	Program	No need to adjust.

Note:

(*3) XX: country code, YY: revision number

"XX" and "YY" vary depending on the country version. You can find them in the batch file, PQZZ- mentioned in **JIG and PC** (P.39).

(*4) Refer to **Check Point (Handset)** (P.35)

11 RF SPECIFICATION

11.1. Base Unit

Item	Value	Refer to -. *	Remarks
TX Power	20 dBm ~ 25 dBm	Check Point (Base Unit) (I)	
Modulation	-350 ~ -400/+320 ~ +370 kHz/div	Check Point (Base Unit) (J)	Data type: Fig31
Frequency Offset	-45 kHz ~ +45 kHz	Check Point (Base Unit) (K)	
Frequency Drift	< ± 30 kHz / ms	Check Point (Base Unit) (L)	
RX Sensitivity	< 1000 ppm	Check Point (Base Unit) (M)	
Timing Accuracy	< ± 2.0 ppm	Check Point (Base Unit) (N)	
RSSI Level	0x22 hex ± A hex	Check Point (Base Unit) (O)	
Power RAMP	Power RAMP is matching	Check Point (Base Unit) (P)	

*: Refer to **Check Point (Base Unit) (P.27)**

11.2. Handset

Item	Value	Refer to -. **	Remarks
TX Power	20 dBm ~ 25 dBm	Check Point (Handset) (K)	
Modulation	-350 ~ -400/+320 ~ +370 kHz/div	Check Point (Handset) (L)	Data type: Fig31
Frequency Offset	-45 kHz ~ +45 kHz	Check Point (Handset) (M)	
Frequency Drift	< ± 30 kHz / ms	Check Point (Handset) (N)	
RX Sensitivity	< 1000 ppm	Check Point (Handset) (O)	
Timing Accuracy	< ± 2.0 ppm	Check Point (Handset) (P)	
RSSI Level	0x1B hex ± 8 hex (at -81dBm) 0x23 hex ± 8 hex (at -63dBm)	Check Point (Handset) (Q)	
Power RAMP	Power RAMP is matching	Check Point (Handset) (R)	

.: Refer to **Check Point (Handset) (P.35)

12 HOW TO CHECK THE SPEAKER OR RECEIVER

1. Prepare the digital voltmeter, and set the selector knob to ohm meter.
2. Put the probes at the speaker (receiver) terminals as shown below.

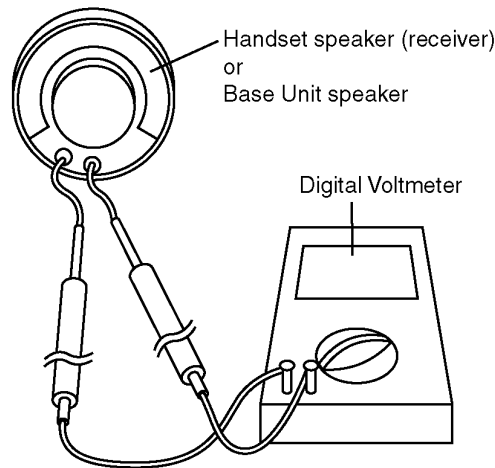
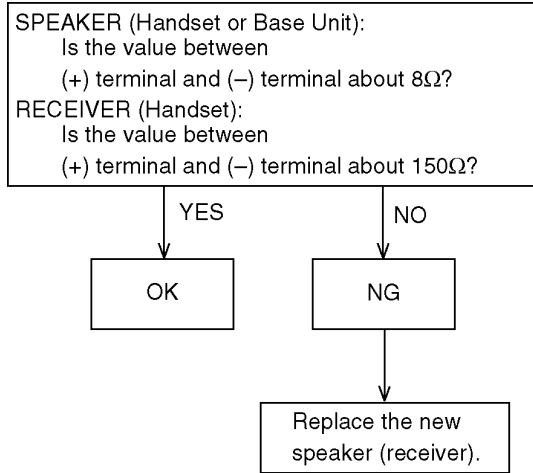

13 FREQUENCY TABLE (MHz)

Channel No	BASE UNIT		HANDSET	
	Transmit Frequency	Receive Frequency	Transmit Frequency	Receive Frequency
1	1897.344	1897.344	1897.344	1897.344
2	1895.616	1895.616	1895.616	1895.616
3	1893.888	1893.888	1893.888	1893.888
4	1892.160	1892.160	1892.160	1892.160
5	1890.432	1890.432	1890.432	1890.432
6	1888.704	1888.704	1888.704	1888.704
7	1886.976	1886.976	1886.976	1886.976
8	1885.248	1885.248	1885.248	1885.248
9	1883.520	1883.520	1883.520	1883.520
10	1881.792	1881.792	1881.792	1881.792

Note:

Channel No. 10: In the Test Mode on Base Unit and Handset.

14 BLOCK DIAGRAM (BASE UNIT)

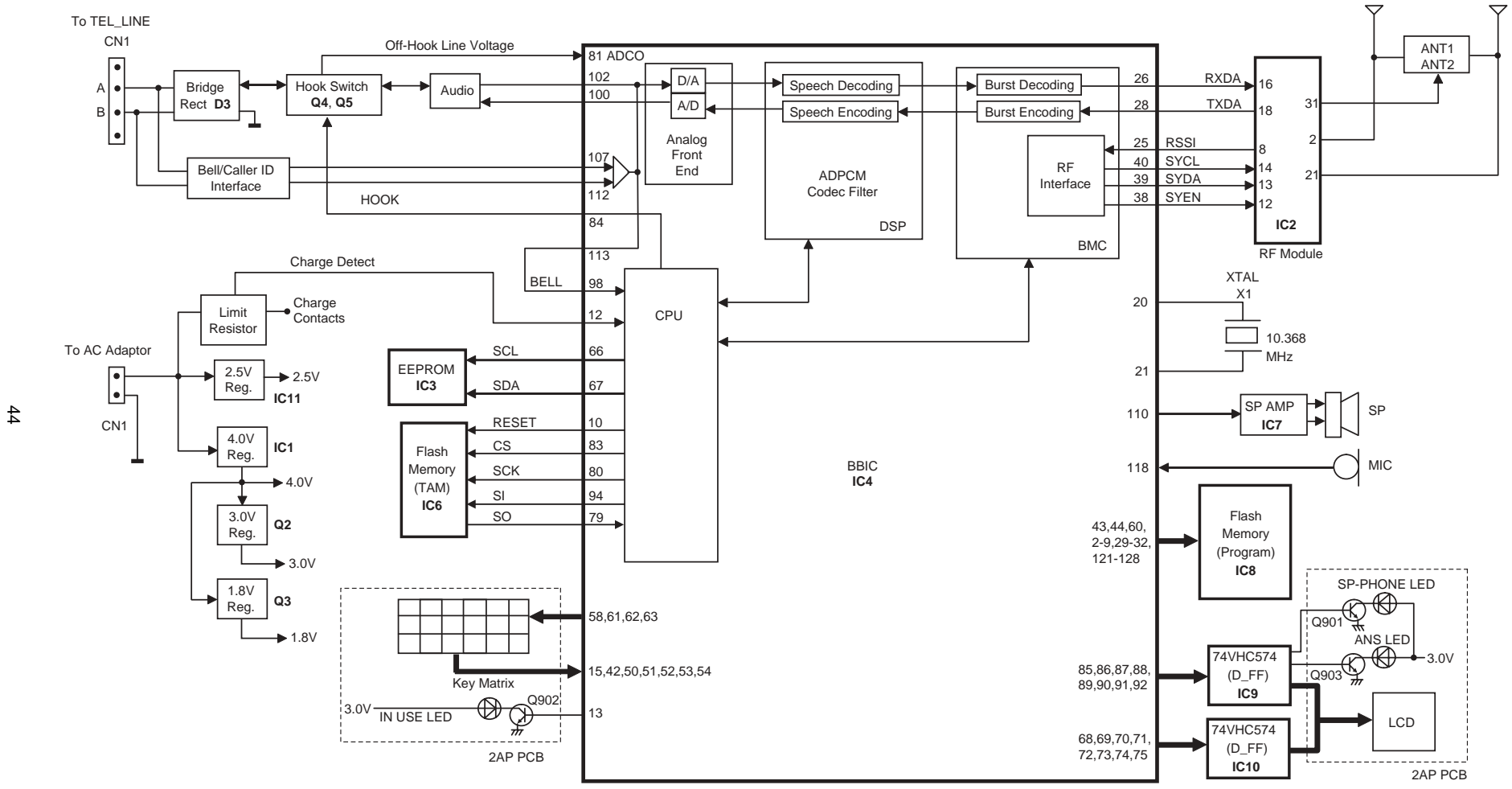

KX-TCD346 BLOCK DIAGRAM (BASE UNIT)

KX-TCD346UAS / KX-TCD346UAT / KX-TC-A132UAS / KX-TC-A132UAT / KX-TC-A130UAS / KX-TC-A130UAT

15 CIRCUIT OPERATION (BASE UNIT)

15.1. Outline

Base Unit consists of the following ICs as shown in **BLOCK DIAGRAM (BASE UNIT)** (P.44).

- DECT BBIC (**B**ase **B**and IC): IC4
 - Handling all the audio, signal and data processing needed in a DECT base unit
 - Controlling the DECT specific physical layer and radio section (**B**urst **M**odule **C**ontroller section)
 - ADPCM codec filter for speech encoding and speech decoding (DSP section)
 - Echo-cancellation and Echo-suppression (DSP section)
 - Any tones (tone, sidetone, ringing tone, etc.) generation (DSP section)
 - DTMF receiver (DSP section)
 - Clock Generation for RF Module
 - ADC, DAC, timer, and power control circuitry
 - All interfaces (ex: RF module, EEPROM, LED, Analog Front End, etc.)
- RF Module: IC2
 - PLL Oscillator
 - Detector
 - Compress/Expander
 - First/Second Mixer
 - Amplifier for transmission and reception
- EEPROM: IC3
 - Temporary operating parameters (for RF, etc.)
- FLASH MEMORY: IC6
 - Voice Prompt (TAM) D/L (Down Load) Area
- FLASH MEMORY: IC8
 - Program D/L (Down Load) Area
- Additionally,
 - Power Supply Circuit (+4.0V, +3.0V, +2.5V, +1.8V output)
 - Crystal Circuit (10.368MHz)
 - Charge Circuit
 - Telephone Line Interface Circuit
 - SP Phone Circuit

15.2. Power Supply Circuit

The power is supplied to the DECT BBIC, RF Module, EEPROM and Charge Contact from AC Adaptor (+6V) as shown in Fig.101. The power supply is as follows;

- DECT BBIC (IC4):
CN1 (+6V) → D1 → IC1 → Q2 → IC4 (3.0V)
CN1 (+6V) → D1 → IC1 → Q3 → IC4 (1.8V)
- RF Module (IC2):
CN1 (+6V) → D1 → IC11 → IC2 (2.5V)
- EEPROM (IC3):
CN1 (+6V) → D1 → IC1 → Q2 → IC3 (3.0V)
- FLASH MEMORY (IC8):
CN1 (+6V) → D1 → IC1 → Q2 → IC8 (3.0V)
- SP AMP (IC7):
CN1 (+6V) → D1 → IC1 → IC7 (4.0V)
- TAM FLASH MEMORY (IC6):
CN1 (+6V) → D1 → IC1 → Q2 → IC6 (3.0V)
- LOGIC IC (IC9, IC10):
CN1 (+6V) → D1 → IC1 → Q2 → IC9, IC10 (3.0V)
- Charge Contact (TP15):
CN1 (+6V) → D1 → R2, R4 → TP15

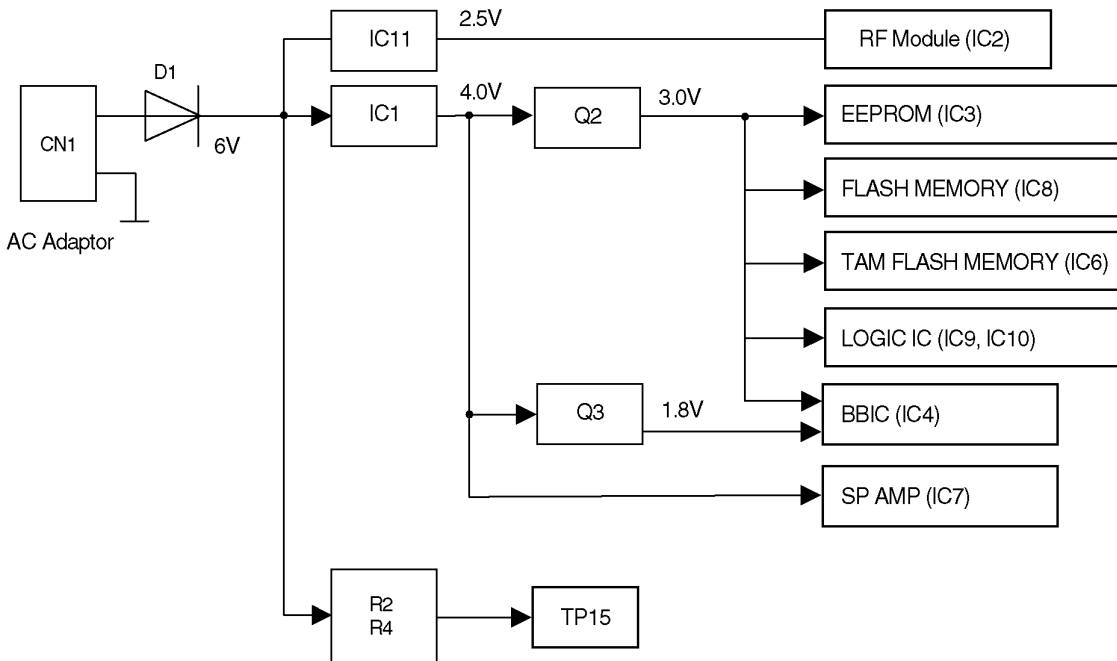

<Fig.101>

15.3. Telephone Line Interface

<Function>

- Bell signal detection
- Clip signal detection
- ON/OFF hook circuit
- Audio circuits
- DTMF tone signal circuits

Bell & Clip (: Calling Line Identification Presentation: Caller ID) signal detection:

In the standby mode, Q4 is open to cut the DC loop current and decrease the ring load.

When ring voltage appears at the L1T (A) and L1R (B) leads (when the telephone rings), the AC ring voltage is transferred as follows;

- A → C13 → R17 → R24 → IC4 Pin 107 (CID INp)
- B → C12 → R16 → R32 → IC4 Pin 112 (CID INn)

ON/OFF hook circuit:

In the standby mode, Q4 is open, and connected as to cut the DC loop current and to cut the voice signal. The unit is consequently in an **on-hook condition**.

When press SP Key onto the base unit or press the TALK Key onto the handset, Q5 turns on and then Q4 turns on, thus providing an **off-hook condition** (active DC current flow through the circuit) and the following signal flow is for the loop current.

- A → D3 → Q4 → Q8 → R45 → R46 → D3 → B [**OFF HOOK**]

15.4. Transmitter/Receiver

Base Unit and Handset mainly consist of RF Module and DECT BBIC.

Base Unit and Handset transmit/receive voice signal and data signal through the antenna on carrier frequency.

Signal Path:

*Refer to **SIGNAL ROUTE** (P.51).

15.4.1. Transmitter Block

The voice signal input from the TEL LINE interface goes to RF Module (IC2) through DECT BBIC (IC4) as shown in **BLOCK DIAGRAM (BASE UNIT)** (P.44)

The voice signal passes through the analog part of IC4 where it is amplified and converted to a digital audio stream signal. The burst switch controller processes this stream performing encryption and scrambling, adding the various other fields to produce the GAP (**Generic Access Profile**) standard DECT frame, assigning to a time slot and channel etc.

In IC2, the carrier frequency is changing, and frequency modulated RF signal is generated and amplified, and radiated from antenna. Handset detects the voice signal or data signal in the circuit same as the following explanation of Receiver Block.

15.4.2. Receiver Block

The signal of 19.2 MHz band (18.81792 MHz ~ 18.97344 MHz) which is input from antenna is input to IC2 as shown in **BLOCK DIAGRAM (BASE UNIT)** (P.44).

In IC2, the signal of 19.2 MHz band is downconverted to 864 kHz signal and demodulated, and goes to IC4 as GAP (**Generic Access Profile**) standard DECT frames. It passes through the decoding section burst switch controller where it separates out the frame information and performs de-encryption and de-scrambling as required. It then goes to the DSP section where it is turned back into analog audio. This is amplified by the analog front end, and goes to the TEL LINE Interface.

15.5. Pulse Dialling

During pulse dialling the hookswitch (Q4,Q5) is used to generate the pulses using the HOOK control signal, which is set high during pulses. To force the line impedance low during the "pause" intervals between dial pulses, the PULSE_DIAL signal turns on Q12.

16 BLOCK DIAGRAM (HANDSET)

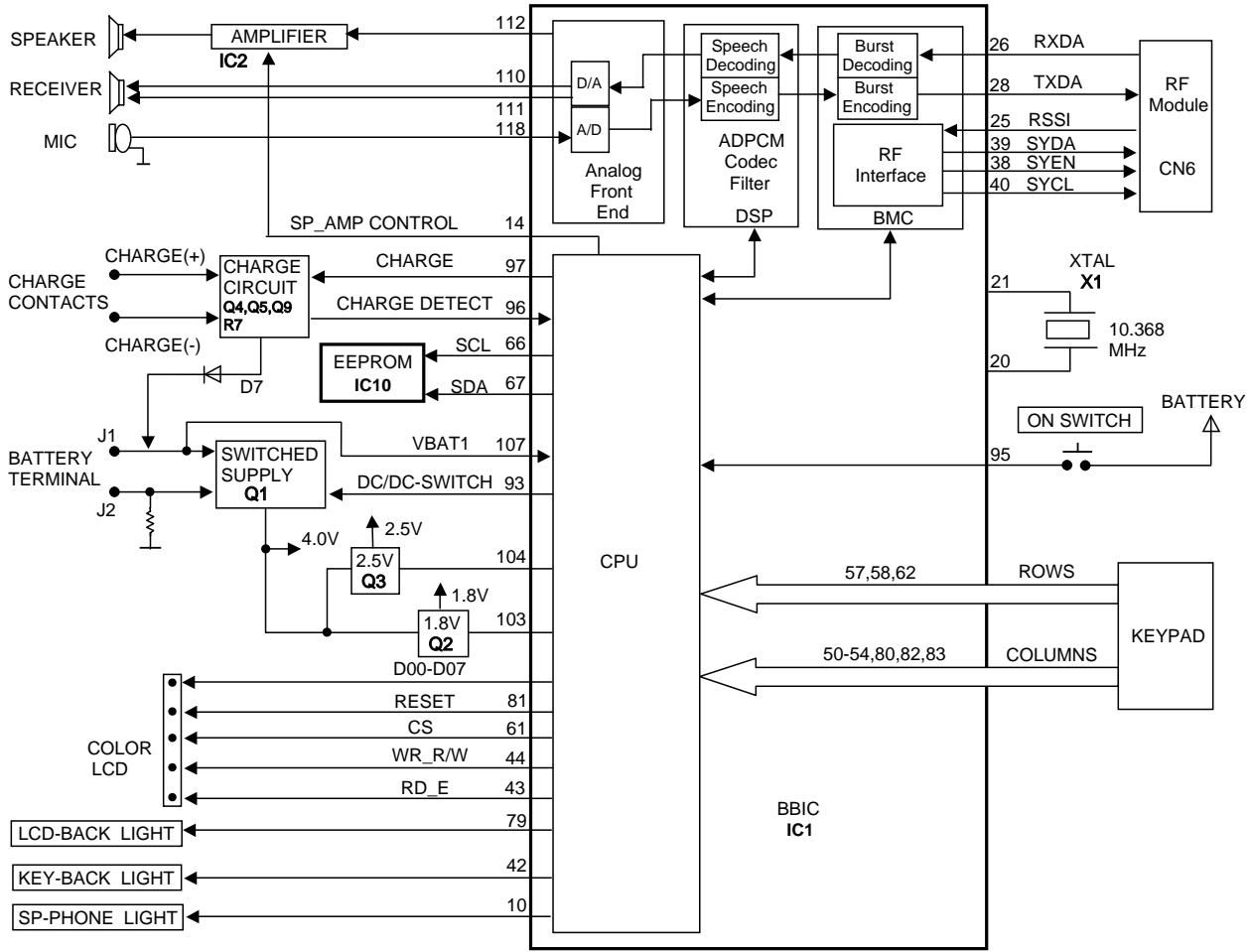

KX-TCA132/TCA130 BLOCK DIAGRAM (HANDSET)

17 CIRCUIT OPERATION (HANDSET)

17.1. Outline

Handset consists of the following ICs as shown in **BLOCK DIAGRAM (HANDSET)** (P.48).

- DECT BBIC (Base Band IC): IC1
 - All data signals (forming/analyzing ACK or CMD signal)
 - All interfaces (ex: Key, Detector Circuit, Charge, DC/DC Converter, EEPROM, LCD)
- RF Module: CN6
 - PLL Oscillator
 - Detector
 - Compress/Expander
 - Amplifier for transmission and reception
- AMP: IC2
 - Single OP_AMP for SP
- EEPROM: IC10
 - Temporary operating parameters (for RF, etc.)
- FLASH: IC11
 - Program D/L (Down Load) Area

17.2. Power Supply Circuit/Reset Circuit

Circuit Operation:

When power on the Handset, the voltage is as follows;

BATTERY(2.2 V ~ 2.6 V: J1) → F1, L1, D1 → Q2 (1.8 V), Q3 (2.5 V), Q1 (4.0 V)

The Reset signal generates IC1 (120 pin) and 1.8 V.

17.3. Charge Circuit

Circuit Operation:

When charging the handset on the Base Unit, the charge current is as follows;

DC+(5.5V ~ 6V) → D1 → R2, R4 → D361 → L13 → CHARGE+(Base) → CHARGE+(Handset) → L4 → Q4 → D7 → F1 → BATTERY+ ... Battery ... BATTERY- → R43 → GND → L5 → CHARGE-(Handset) → CHARGE-(Base) → GND → L14 → DC-(GND)

In this way, the BBIC on Handset detects the fact that the battery is charged.

The charge current is controlled by switching Q5 of Handset.

Refer to Fig.101 in **Power Supply Circuit** (P.46).

17.4. Battery Low/Power Down Detector

Circuit Operation:

"Battery Low" and "Power Down" are detected by BBIC which check the voltage from battery.

The detected voltage is as follows;

- Battery Low

Battery voltage: $V(\text{Batt}) \leq 2.25V \pm 50mV$

The BBIC detects this level and "█" starts flashing.

- Power Down

Battery voltage: $V(\text{Batt}) \leq 2.00V \sim 2.05V$

The BBIC detects this level and power down.

Refer to **Check Point (Handset)** (P.35).

17.5. Speakerphone

The hands-free loudspeaker at SP+ and SP- works as a ringer/alarm as well. IC2 is used to switch off the telephone loudspeaker and is used to amplify the signal to drive the hands-free loudspeaker. They are selected using the SP_AMP line from pin 112 of the BBIC.

Refer to **Troubleshooting for Speakerphone (Handset)** (P.38).

18 CIRCUIT OPERATION (CHARGER UNIT)

18.1. Power Supply Circuit

The power supply is as shown.

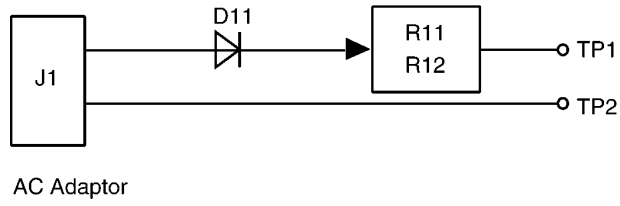

19 SIGNAL ROUTE

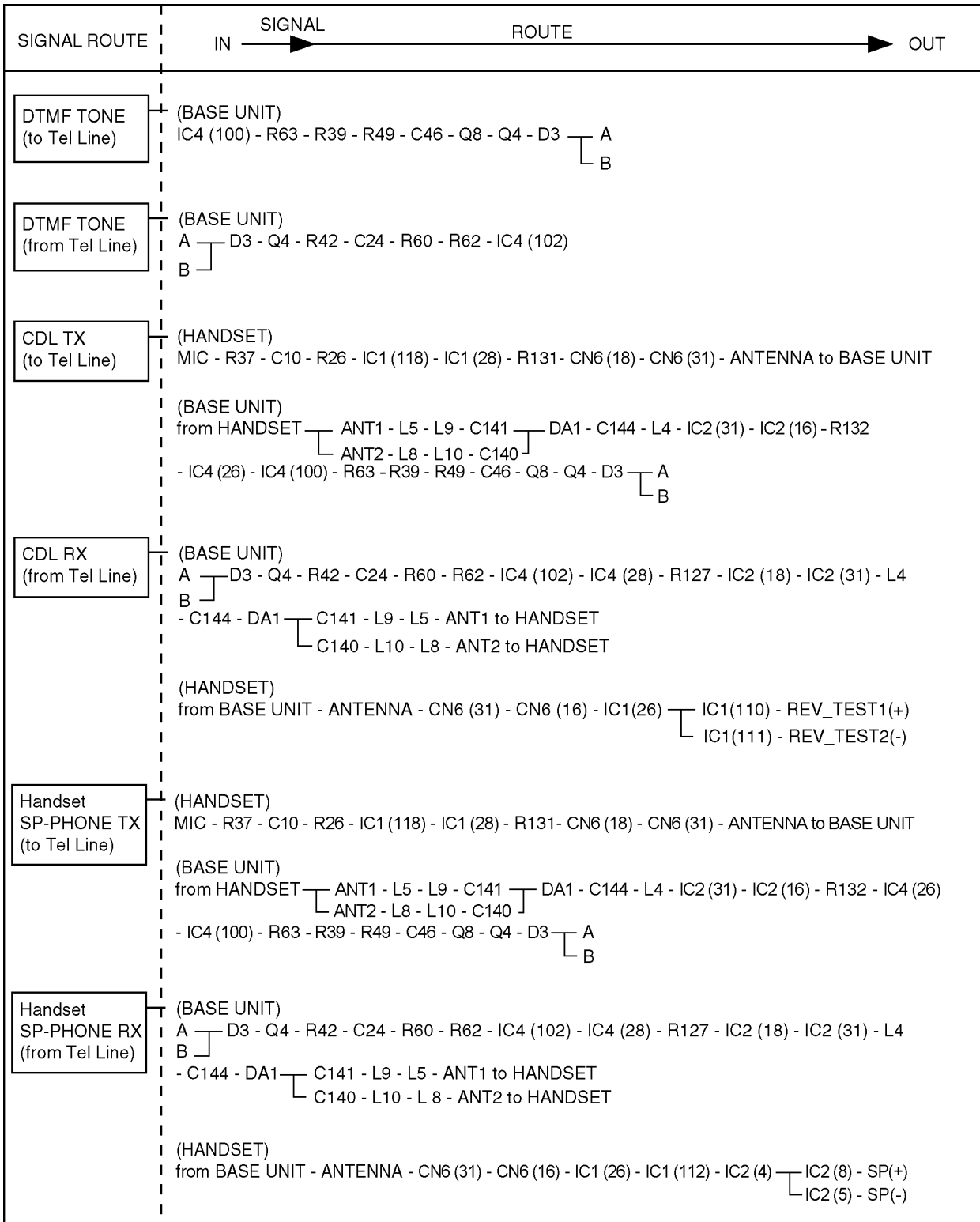

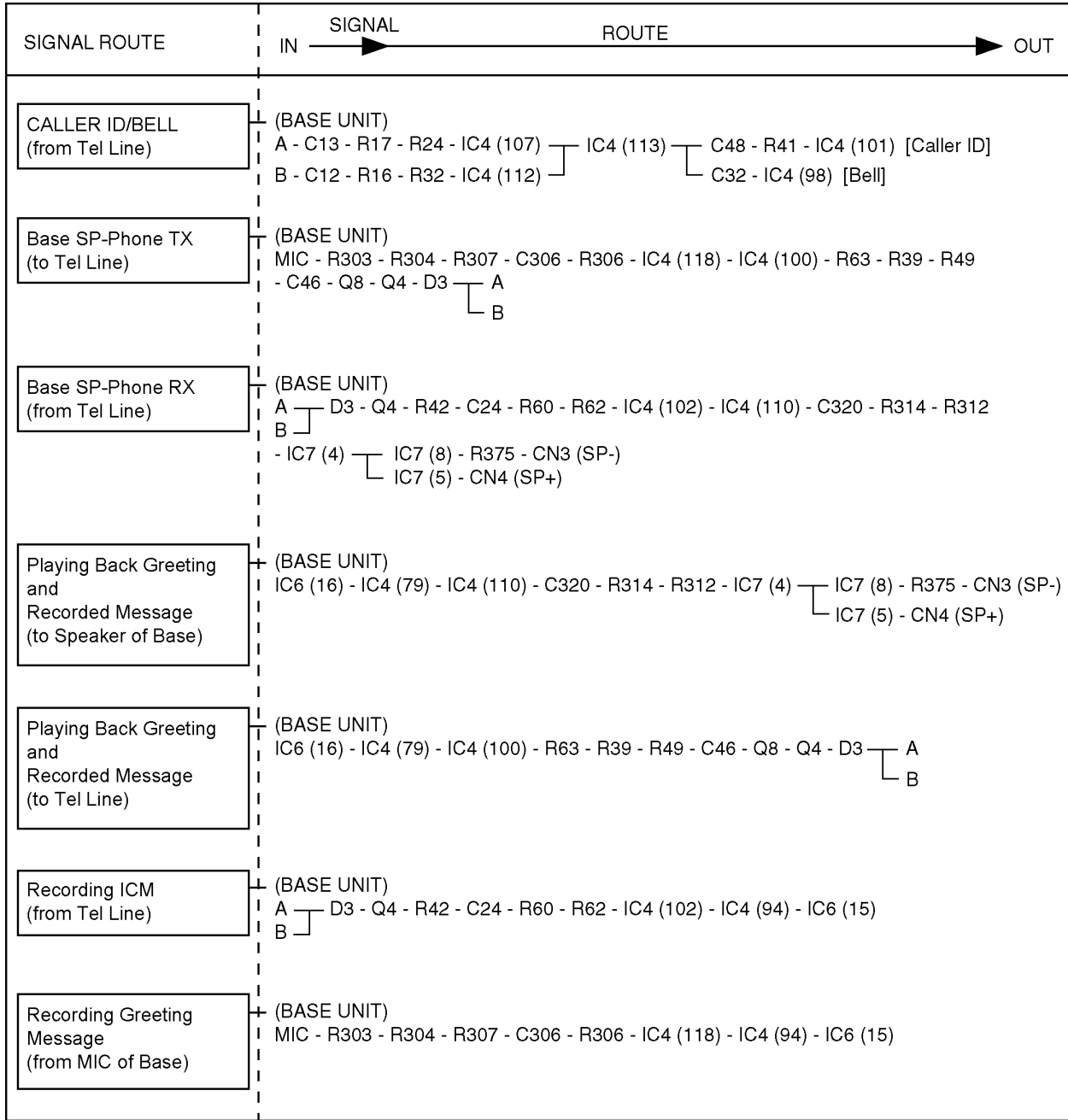

20 CPU DATA (BASE UNIT)

20.1. IC4 (BBIC)

Pin No	Description	I/O	Connection	at Normal mode	at Reset mode
1	VDDIO	-	VDDID	-	-
2	VSS	-	VSS	-	-
3	AD8	D.O	AD8	O	Hi
4	AD9	D.O	AD9	O	Hi
5	AD10	D.O	AD10	O	Hi
6	AD11	D.O	AD11	O	Hi
7	AD12	D.O	AD12	O	Hi
8	AD13	D.O	AD13	O	Hi
9	AD14	D.O	AD14	O	Hi
10	RESET	D.O	RESET	O	Hi-Z
11	SP_AMP_CS	D.O	SP_AMP_CS	O	Hi-Z
12	CHARGE DET	D.I	CHARGE DETECT	I	Hi-Z
13	INUSE_LED	D.O	INUSE_LED	O	Hi-Z
14	SP_LED	D.O	SP_LED	O	Hi-Z
15	KEY_OUT6	D.O	key_strobe	O	Hi-Z
16	VDD	-	VDD	-	-
17	VSS	-	VSS	-	-
18	RFCLK	D.O	RFCLK	O	Low
19	VDDRF	-	VDDRF	-	-
20	VSSRF	-	VSSRF	-	-
21	Xtal1	A.I	Xtal1	I	I
22	CAP	A.I	CAP	I	I
23	AVS	-	AVS	-	-
24	AVD	-	AVD	-	-
25	RSSI	A.I	RSSI	I	I
26	RXDA	A.I	RXDA	I	I
27	CMPREF	A.I	CMPREF	I	I
28	TXDA	A.O	TXDA	O	Hi-Z
29	AD15	D.O	AD15	O	Hi
30	AD16	D.O	AD16	O	Hi
31	AD17	D.O	AD17	O	Hi
32	AD18	D.O	AD18	O	Hi
33	AD19	D.O	NC	O	Hi
34	AD20	D.O	NC	O	Hi
35	AD21	D.O	NC	O	Hi
36	AD22	D.O	NC	O	Hi
37	AD23	D.O	NC	O	Hi
38	LE	D.O	LE	O	Low
39	SO	D.O	SO	O	Low
40	SK	D.O	SK	O	Hi-Z
41	ADC2	A.I	ADC2	I	I
42	KEY_OUT5	D.O	key_strobe	O	Hi-Z
43	RDN	D.O	RDN	O	Hi
44	WRN	D.O	WRN	O	Hi
45	MI/READY	D.O	NC	O	I
46	SCLK	D.O	NC	O	Hi
47	UTX	D.O	UTX	O	I
48	URX	D.I	URX	I	I
49	JTIO	D.I/O	JTIO	I/O	I
50	KEY_OUT4	D.I	key_strobe	I	I
51	KEY_OUT3	D.I	key_strobe	I	I
52	KEY_OUT2	D.I	key_strobe	I	I
53	KEY_OUT1	D.I	key_strobe	I	I
54	KEY_OUT0	D.I	key_strobe	I	I
55	VDDIO	-	VDDIO	-	-
56	VSS	-	VSS	-	-
57	RDY/BUSY	D.O	RDY/BUSY	O	I
58	KEY_IN3	D.O	key_input with internal pull up	O	I
59	ACS1	D.O	ACS1	O	I
60	ACS0	D.O	ACS0	O	Hi
61	KEY_IN2	D.O	key_input with internal pull up	O	I

Pin No	Description	I/O	Connection	at Normal mode	at Reset mode
62	KEY_IN1	D.I	key_input with internal pull up	I	I
63	KEY_IN0	D.I	key_input with internal pull up	I	Hi
64	NC	D.O	NC	O	Hi
65	NC	D.O	NC	O	Hi
66	SCL	D.O	SCL	O	Hi-Z
67	SDA	D.I/O	SDA	I/O	I
68	DAB0	D.I/O	DAB0	I/O	I
69	DAB8	D.I/O	DAB8	I/O	I
70	DAB1	D.I/O	DAB1	I/O	I
71	DAB9	D.I/O	DAB9	I/O	I
72	DAB2	D.I/O	DAB2	I/O	I
73	DAB10	D.I/O	DAB10	I/O	I
74	DAB3	D.I/O	DAB3	I/O	I
75	DAB11	D.I/O	DAB11	I/O	I
76	VSS	-	VSS	-	-
77	VDD	-	VDD	-	-
78	VDDIO	-	VDDIO	-	-
79	SO	D.O	SO	O	I
80	SCK/CLK	D.O	SCK/CLK	O	I
81	ADC0	A.I	ADC0	I	I
82	ADC1	A.I	ADC1	I	I
83	CS	D.O	CS	O	I
84	HOOK	D.O	HOOK	O	I
85	DAB4	D.I/O	DAB4	I/O	I
86	DAB12	D.I/O	DAB12	I/O	I
87	DAB5	D.I/O	DAB5	I/O	I
88	DAB13	D.I/O	DAB13	I/O	I
89	DAB6	D.I/O	DAB6	I/O	I
90	DAB14	D.I/O	DAB14	I/O	I
91	DAB7	D.I/O	DAB7	I/O	I
92	DAB15	D.I/O	DAB15	I/O	I
93	TM	D.I	TM	I	Low
94	SI	D.O	SI	O	Hi-Z
95	PON	A.I	PON	I	I
96	PULSE	D.I/O	nHOOK	I/O	I
97	RLY	D.O	RLY	O	Low
98	RINGING	A.I	RINGING	I	I
99	LINEREF	A.O	LINEREF	O	-
100	LINEOUT	A.O	LINEOUT	O	-
101	LINE_IN+	A.I	LINE_IN+	I	-
102	LINE_IN-	A.I	LINE_IN-	I	-
103	LDO1_Senes	A.I	LDO1_Senes	I	I
104	LDO1_CTRL	A.O	LDO1_CTRL	O	Hi
105	LDO2_CTRL	A.O	LDO2_CTRL	O	Low
106	VBAT2	A.I	VBAT2	I	I
107	CIDIN+	A.I	CIDIN+	I	I
108	AVS2	-	AVS2	-	-
109	AVD2	-	AVD2	-	-
110	LSR+/REF	A.O	LSR+/REF	O	O
111	LSR-/REF	A.O	NC	O	O
112	CIDIN-	A.I	CIDIN-	I	O
113	CIDOUT	A.O	CIDOUT	O	O
114	MIC-	A.I	NC	I	I
115	VREF-	A.O	VREF-	O	O
116	VBUF	A.O	VBUF	O	O
117	AGND	A.O	AGND	O	O
118	MIC+	A.I	MIC+	I	I
119	VREF+	A.O	NC	O	I
120	RSTn	A.I	RSTn	I	I
121	EXT_MEMORY	D.I	EXT_MEMORY	I	I
122	AD1	D.O	AD1	O	Hi
123	AD2	D.O	AD2	O	Hi
124	AD3	D.O	AD3	O	Hi
125	AD4	D.O	AD4	O	Hi
126	AD5	D.O	AD5	O	Hi

Pin No	Description	I/O	Connection	at Normal mode	at Reset mode
127	AD6	D.O	AD6	O	Hi
128	AD7	D.O	AD7	O	Hi

21 CPU DATA (HANDSET)

21.1. IC1 (BBIC)

Pin No	Description	I/O	Connection	at Normal mode	at Reset mode
1	VDDIO	-	-	-	-
2	VSS	-	-	-	-
3	AD8	D,O	AD8	O	O-H
4	AD9	D,O	AD9	O	O-H
5	AD10	D,O	AD10	O	O-H
6	AD11	D,O	AD11	O	O-H
7	AD12	D,O	AD12	O	O-H
8	AD13	D,O	AD13	O	O-H
9	AD14	D,O	AD14	O	O-H
10	P3_7/PD7	D,O	P3_7	O	O-Hi-Z
11	P3_1/PD1	D,O	P3_1	O	O-Hi-Z
12	P3_5/PD5	D,O	P3_5	O	O-Hi-Z
13	P3_4/PD4	D,O	NC	O	O-Hi-Z
14	P3_3/PD3	D,O	CD_AMP	O	O-Hi-Z
15	P3_2/PD2	D,O	NC	O	O-Hi-Z
16	VDD	-	-	-	-
17	VSS	-	-	-	-
18	RFCLK	D,O	RFCLK	O	O
19	VDDRF	-	VDDRF	-	-
20	VSSRF	-	VSSRF	-	-
21	Xtal1	A,I	Xtal1	I	-
22	CAP	A,I	CAP	I	-
23	AVS	-	AVS	-	-
24	AVD	-	AVD	-	-
25	RSSI	A,I	RSSI	I	I
26	RDI	D,I	RDI	I	I
27	CMPREF	A,I	NC	OPEN	I
28	TDO	A,O	TXDA	A,O	Hi-Z
29	AD15	D,O	AD15	O	O-H
30	AD16	D,O	AD16	O	O-H
31	AD17	D,O	AD17	O	O-H
32	AD18	D,O	AD18	O	O-H
33	AD19	D,O	AD19	O	O-H
34	AD20	D,O	NC	O	O-H
35	AD21	D,O	NC	O	O-H
36	AD22	D,O	NC	O	O-H
37	AD23	D,O	NC	O	O-H
38	LE	D,O	LE	D,O	O
39	SO	D,O	SIO	D,O	O-Hi-Z
40	SK	D,O	SK	D,O	O
41	DAC/ADC2	A,I	NC	I	I
42	P3_6/PD6	D,O	P3_6	D,O	O-Hi-Z
43	RDN	D,O	RE	O	O-H
44	WRN	D,O	WR	O	O-H
45	MI/READY	D,O	NC	OPEN	I-PU
46	SCLK	D,O	NC	OPEN	O-H
47	UTX/P0_0	D,O	UTX	O	I
48	URX/P0_1	D,I	URX	I	I
49	JTIO/P0_2	D,I	JTAG	I	I
50	PCM_FSC1/P0_3	D,I/O	COL4	OPEN	I-PU
51	PCM_FSC0/P0_4	D,I/O	COL3	OPEN	I-PU
52	PCM_CLK/P0_5	D,I/O	COL2	OPEN	I-PU
53	PCM_DOUT/P0_6	D,I/O	COL1	OPEN	I-PU
54	PCM_DINP/P0_7	D,I/O	COL0	OPEN	I-PU
55	VDDIO	-	VDDIO	-	-
56	VSS	-	VSS	-	-
57	INT0n/P1_0	D,I	ROW2	I	I-PU
58	INT1n/P1_1	D,O	ROW1	I	I-PU
59	INT2n/P1_2/ACS1	D,O	NC	OPEN	I-PU
60	ACS0	D,O	CE_FLASH	O	O-H
61	INT3n/P1_3/ACS2	D,O	CS_LCD	OPEN	I-PU
62	INT4n/P1_4	D,O	ROW0	I	I-PU

Pin No	Description	I/O	Connection	at Normal mode	at Reset mode
63	VDDE/INT5n/P1_5	D,O	NC	OPEN	O-H
64	BE1n	D,I/O	NC	OPEN	O-H
65	BE0n	D,I/O	NC	OPEN	O-H
66	SCL2/P3_0	D,O	SCL	O	O
67	SDA2	D,I/O	SDA	O	I
68	DAB0	D,I/O	DQ0	I/O	O-H
69	DAB8	D,I/O	DQ8	I/O	O-H
70	DAB1	D,I/O	DQ1	I/O	O-H
71	DAB9	D,I/O	DQ9	I/O	O-H
72	DAB2	D,I/O	DQ2	I/O	O-H
73	DAB10	D,I/O	DQ10	I/O	O-H
74	DAB3	D,I/O	DQ3	I/O	O-H
75	DAB11	D,I/O	DQ11	I/O	O-H
76	VSS	-	VSS	-	-
77	VDD	-	VDD	-	-
78	VDDIO	-	VDDIO	-	-
79	P2_0/PWM0/SPIDI	D,O	P2_0	O	I
80	P2_1/PWM1/SPICLK	D,O	COL5	OPEN	I
81	P2_2/ADC0/CLK100	D,O	RES_LCD	I	I
82	P2_3/ADC1	D,O	COL6	OPEN	I
83	P2_4/SCL1	D,O	COL7	OPEN	I
84	P2_5/SDA1	D,O	RESET	OPEN	I
85	DAB4	D,I/O	DQ4	I/O	O-H
86	DAB12	D,I/O	DQ12	I/O	O-H
87	DAB5	D,I/O	DQ5	I/O	O-H
88	DAB13	D,I/O	DQ13	I/O	O-H
89	DAB6	D,I/O	DQ6	I/O	O-H
90	DAB14	D,I/O	DQ14	I/O	O-H
91	DAB7	D,I/O	DQ7	I/O	O-H
92	DAB15	D,I/O	DQ15	I/O	O-H
93	P2_7/DC_CTRL	D,O	DC_CTL	D,O	O (fixed 100k pull down)
94	DC_I	A,I	DC_I	I	I
95	P1_6/PON/INT6n	A,I	PON	I	I
96	P1_7/CHARGE/INT7n	A,I	CHARGE	I	I (fixed 160k pull down)
97	P2_6/stop_charge	A,O	stop_charge	OPEN	O
98	VBAT3/RINGING	A,I	VBAT3	I	I
99	DC_stab	A,O	DC_stab	OPEN	O
100	DC_Sense	A,I	DC_Sense	-	I
101	AVS_sense	A,I	AVS_sense	-	I
102	ADC3	A,I	ADC3	I	I
103	LDO1_sense	A,I	LDO1_sense	I	I
104	LDO1_CTRL	A,O	LDO1_CTRL	O	O
105	LDO2_CTRL	A,O	LDO2_CTRL	O	O
106	VBAT2	A,I	VBAT2	I	I
107	VBAT1	A,I	VBAT1	I	I
108	AVS2	-	AVS2	-	-
109	AVD2	-	AVD2	-	-
110	LSR+/REF	A,O	LSR+	O	O
111	LSR-/REF	A,O	LSR-	O	O
112	LSR_HS/CIDIN-	A,I	CIDIN-	O	O
113	VREF_HS/CIDOUT	A,O	NC	O	O
114	MIC-	A,I	NC	I	I
115	-	A,O	-	-	O
116	VBUF	A,O	VBUF	OPEN	O
117	AGND	A,O	AGND	O	O
118	MIC+	A,I	MIC+	I	I
119	VREF+/CIDIN+	A,I	CIDIN+	I	I
120	RSTN	D,I	RSTN	I	I-PU
121	AD0	D,O	NC	I	O-H
122	AD1	D,O	AD0	O	O-H
123	AD2	D,O	AD1	O	O-H
124	AD3	D,O	AD2	O	O-H
125	AD4	D,O	AD3	O	O-H
126	AD5	D,O	AD4	O	O-H
127	AD6	D,O	AD5	O	O-H
128	AD7	D,O	AD6	O	O-H

22 ENGINEERING MODE

22.1. Base Unit

Important:

Make sure the address on LCD is correct when entering new data. Otherwise, you may ruin the unit.

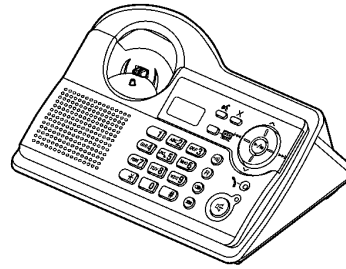
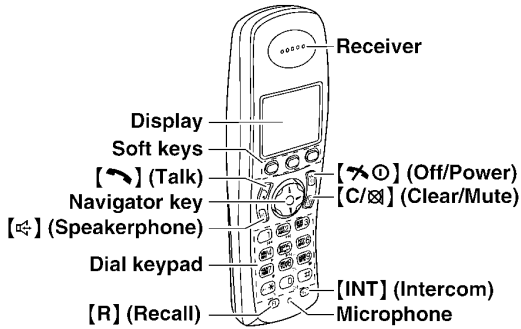

Model shown is KX-TCA132.

H/S key operation

- 1). Register a Handset to a Base Unit.
- 2). Press " [Menu] " (menu) key, then select "Base Unit Setup" by navigator key.
- 3). Press " [OK] " (menu).
- 4). Enter "0", "0", "0", "0".
Note: This 4 digits are default setting.
- 5). Select "Other Options".
- 6). Press " [OK] " (menu).
- 7). Select "Base Unit PIN".
- 8). Press " [OK] " (menu).

H/S LCD

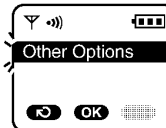

9). Enter "7", "2", "6", "2".

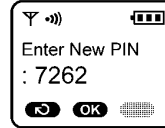

10). Enter "7", "6", "6", "4".

Note: 7262 7664 = PANA SONI
(see alphabets printed on dial keys)



11). Press "OK" (menu).



12). Select "Write EEPROM".



13). Press "OK" (menu).



14). Enter "0", "0", "0", "0" (Address). *

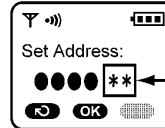

15). Enter "*" (New Data).

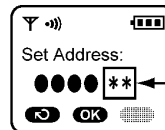

16). Press "OK" (menu).
A long confirmation beep will be heard.

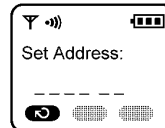

17). Press "Power Off" (off) to return to standby mode.
After that, turn the base unit power off and then power on.

Note:

*: When you enter the address, please refer to the table below.

Desired Number (hex)	Input Keys	Desired Number (hex)	Input Keys
0	0	A	[R] + 0
1	1	B	[R] + 1
.	.	C	[R] + 2
.	.	D	[R] + 3
.	.	E	[R] + 4
9	9	F	[R] + 5

ex.)

Items (*2)	Address	Default Data	New Data		Remarks
C-ID (FSK) sensitivity	04 3D	00	01 (6dB up)	02 (12dB up)	When hex changes from "00" to "01" or "02", gain increases by 6dB or 12dB.
C-ID (DTMF) sensitivity	04 4B	50	60 (6dB up)	70 (12dB up)	When hex changes from "50" to "60" or "70", gain increases by 6dB or 12dB.
Frequency	00 01	75	-	-	Use these items in a READ-ONLY mode to confirm the contents. Careless rewriting may cause serious damage to the computer system.
ID	00 10-00 14	Given value	-	-	
Bell length	01 F6	32 (5sec) (*1)	1E (3sec)	14 (2sec)	This is time until bell stops ringing. (Unit: 100ms)
PULSE Dial speed (10PPS -> 20PPS)	03 48	28 (40msec) (*1)	14 (20msec)	-	This is pulse make time. (Unit:1ms)
	03 49	3C (60msec) (*1)	1E (30msec)	-	This is pulse break time. (Unit:1ms)
	01 E4	57 (870msec) (*1)	2C (440msec)	-	This is inter-digit time in pulse mode. (Unit:10ms)

(*1)

Bell length	32(hex) = 50(dec) → 50 × 100msec = 5000msec (5sec)
PULSE Dial speed (10PPS -> 20PPS)	28(hex) = 40(dec) → 40 × 1msec = 40msec
	3C(hex) = 60(dec) → 60 × 1msec = 60msec
	57(hex) = 87(dec) → 87 × 10msec = 870msec

(*2)

Items	Description
C-ID (FSK) sensitivity	FSKGain_shiftgain
C-ID (DTMF) sensitivity	Foutgains:HPFilter Foutgains
Frequency	Setting value of FREQ_TRIM_REG
ID	ID
Bell length	Time until it stops bell.
PULSE Dial speed (10PPS -> 20PPS)	Pulse MakeTime and BreakTime. bMakeTime:Pulse MakeTime Unit: 1ms bBreakTime:Pulse Break Time Unit: 1ms
	Inter-digit time in Pulse mode. Unit:10ms

22.2. Handset

Important:

Make sure the address on LCD is correct when entering new data. Otherwise, you may ruin the unit.

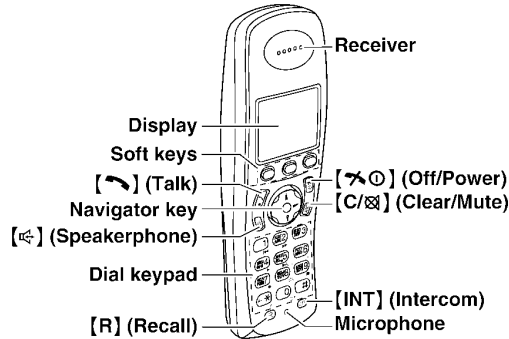

Model shown is KX-TCA132.

H/S key operation

- 1). Press " " (menu) key, then select "Handset Setup" by navigator key.
- 2). Press "OK" (menu).
- 3). Select "Other Options".
- 4). Press "OK" (menu).
- 5). Select "Handset PIN".
- 6). Press "OK" (menu).
- 7). Enter "0", "0", "0", "0".
Note: This 4 digits are default setting.
- 8). Enter "7", "2", "6", "2".

H/S LCD

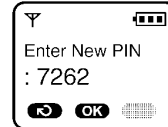
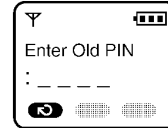
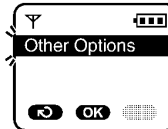
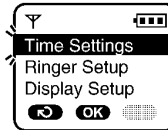

9). Enter "7", "6", "6", "4".
Note: 7262 7664 = PANA SONI
 (see alphabets printed on dial keys)

10). Press "OK" (menu).

11). Select "Write EEPROM".

12). Press "OK" (menu).

13). Enter "0", "0", "0", "0" (Address). *

14). Enter "*", "*" (New Data).

15). Press "OK" (menu).
 A long confirmation beep will be heard.

16). Press "OFF" (off) to return to standby mode.
 After that, turn the handset power off and then power on.

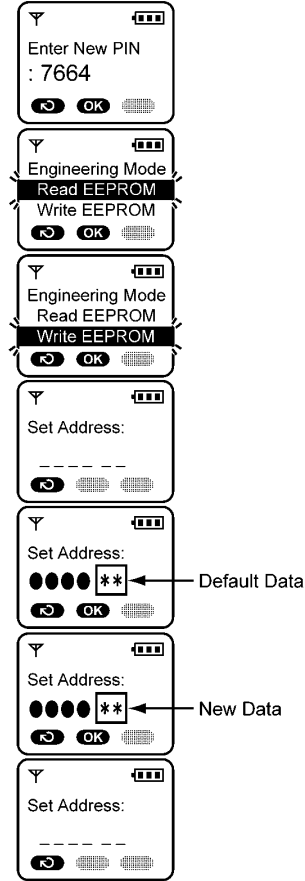

Note:

*: When you enter the address, please refer to the table in **Note:** (P.59) of **ENGINEERING MODE**.

ex.)

Items (*4)	Address	Default Data	New Data	Possible Adjusted Value MAX (hex)	Possible Adjusted Value MIN (hex)	Remarks
Sending level	00 06	Adjusted value	Given value	6F	00	(*1)
Receiving level	00 07	Adjusted value	Given value	00	3F	(*2)
Battery Low	00 04	25	-	-	-	(*3)
Frequency	00 01	75	-	-	-	
ID	00 10~00 14	Given value	-	-	-	

(*1) When adding "01" (hex) to default value, sending level increases by 0.25dB.

ex.)

(*2) When reducing "01" (hex) from default value, receiving level increases by 0.25dB.

ex.)

Item	Default Data	New Data	
	3A	3E	36
Sending level	-7.5dBm	-6.5dBm	-8.5dBm

Item	Default Data	New Data	
	14	18	10
Receiving level	-20.5dBm	-21.5dBm	-19.5dBm

(*3) Use these items in a READ-ONLY mode to confirm the contents. Careless rewriting may cause serious damage to the handset.

(*4)

Items	Description
Sending level	Analog Front End MIC Setting for Handset Mode
Receiving level	Analog Front End LSR Setting for Handset Mode
Battery Low	ADC value for battery low detection
Frequency	Setting value of FREQ_TRIM_REG
ID	International Portable Part Equipment Identities

23 EEPROM LAYOUT (BASE UNIT)

23.1. Scope

The purpose of this section is to describe the layout of the EEPROM (IC3) for the KX-TCD340 Base Unit.

The EEPROM contains hardware, software, and user specific parameters. Some parameters are set during production of the base unit, some are set by the user configuration, and some are set during normal use of the phone.

23.2. Introduction

The base unit uses a 64k bit serial EEPROM (IC3) for storing volatile parameters. All parameters are set up before the base unit leaves the factory. Some of these are vital for the operation of the hardware so a set of default parameters is programmed before the actual hardware fine-tuning can be initiated. This document lists all default settings with a short description.

Initial Type	Description
F	The data initialized by only F command
0	The data initialized by F and 0 command
1	The data initialized by F, 0 and 1 command
2	The data initialized by F, 0, 1 and 2 command
3	The data initialized by all command (F, 0, 1, 2, 3)

Country Setting	Description
x	Default - no specific country setting, so revert to default value.

23.3. EEPROM Layout

23.3.1. General Setup1

Address	Initial Type	Name	Description	Default value	Country Setting
0x0000	-	EEP_EepromType	EEPROM type 0x00:32kbit type 0x55:64kbit type 0xAA:128kbit type other:32kbit type	0x00	0x55
0x0007	F	EEP_ModelInfo	Model information Bit0:TAM...1:Enable, 0:Disable Bit1:Base Phonebook 1...1:Enable, 0:Disable Bit2:Audible Call...1:Enable, 0:Disable Bit3:SP-PHONE...1:Enable, 0:Disable Bit4:FAX...1:Enable, 0:Disable Bit5:TalkOver...1:Enable, 0:Disable Bit7-6:Not used	0x00	0x2F
0x01E0	1	EEP_MenusEnabled	Menus Enabled Bit0:Menu of Select Dial Mode...1:Enable, 0:Disable Bit1:Flash Menu...1:Enable, 0:Disable Bit2-3:Don't Used Bit4:Menu of Select Pause time...1:Enable, 0:Disable Bit5:Battery Type Bit6:Repeater Mode Bit7:Ringer Menu	0xDE	0xDF

23.3.2. General Setup2

Address	Initial Type	Name	Description	Default value	Country Setting
0x0001	F	EEP_FreqTrim_L	Setting value of FREQ_TRIM_REG	0x75	x
0x0002	F	EEP_BandGap	Setting value of BandGap REG	0x08	x
0x0010	-	EEP_Rfpi	Base ID written data by adjustment checker or ID writer RFPI (5Byte)	0xFF, 0xFF, 0xFF, 0xFF, 0xFF	x
0x0300	1	EEP_Rc0	BMC internal Register 0	0x40	x
0x0022	0	EEP_Ps0_InUseFlag	IN-Use Flag 00:Invalid / 01:Valid	0x00	x
0x0023	0	EEP_Ps0_DectPsNo	DECT PS No. 00-3F:PS No. / FF:Invalid	0xFF	x
0x0024	0	EEP_Ps0_PsType	PS Type 00:KME's PS (Group Page) 01:KME's PS (Group Page/Message Waiting) 02:TD-7500 or TD-7590 / FF:Another Maker's PS	0xFF	x

Address	Initial Type	Name	Description	Default value	Country Setting
0x0025	0	EEP_Ps0_lptui	PS ID first byte:0xA8 (Length Information) from second byte:IPUI (Normal:5byte, Max:13byte)	0x00, 0x00, 0x00, 0x00, 0x00, 0x00, 0x00, 0x00, 0x00, 0x00, 0x00, 0x00, 0x00, 0x00	x
0x006A	0	EEP_Ps1_InUseFlag	IN-Use Flag 00:Invalid / 01:Valid	0x00	x
0x006B	0	EEP_Ps1_DectPsNo	DECT PS No. 00-3F:PS No. / FF:Invalid	0xFF	x
0x006C	0	EEP_Ps1_PsType	PS Type 00:KME's PS (Group Page) / 01:KME's PS (Group Page/Message Waiting) 02:TD-7500 or TD-7590 / FF:Another Maker's PS	0xFF	x
0x006D	0	EEP_Ps1_lptui	PS ID IPUI (14Byte)	0x00, 0x00, 0x00, 0x00, 0x00, 0x00, 0x00, 0x00, 0x00, 0x00, 0x00, 0x00, 0x00, 0x00	x
0x00B2	0	EEP_Ps2_InUseFlag	IN-Use Flag 00:Invalid / 01:Valid	0x00	x
0x00B3	0	EEP_Ps2_DectPsNo	DECT PS No. 00-3F:PS No. / FF:Invalid	0xFF	x
0x00B4	0	EEP_Ps2_PsType	PS Type 00:KME's PS (Group Page) / 01:KME's PS (Group Page/Message Waiting) 02:TD-7500 or TD-7590 / FF:Another Maker's PS	0xFF	x
0x00B5	0	EEP_Ps2_lptui	PS ID IPUI (14Byte)	0x00, 0x00, 0x00, 0x00, 0x00, 0x00, 0x00, 0x00, 0x00, 0x00, 0x00, 0x00, 0x00, 0x00	x
0x00FA	0	EEP_Ps3_InUseFlag	IN-Use Flag 00:Invalid / 01:Valid	0x00	x
0x00FB	0	EEP_Ps3_DectPsNo	DECT PS No. 00-3F:PS No. / FF:Invalid	0xFF	x
0x00FC	0	EEP_Ps3_PsType	PS Type 00:KME's PS (Group Page) / 01:KME's PS (Group Page/Message Waiting) 02:TD-7500 or TD-7590 / FF:Another Maker's PS	0xFF	x
0x00FD	0	EEP_Ps3_lptui	PS ID IPUI (14Byte)	0x00, 0x00, 0x00, 0x00, 0x00, 0x00, 0x00, 0x00, 0x00, 0x00, 0x00, 0x00, 0x00, 0x00	x
0x0142	0	EEP_Ps4_InUseFlag	IN-Use Flag 00:Invalid / 01:Valid	0x00	x
0x0143	0	EEP_Ps4_DectPsNo	DECT PS No. 00-3F:PS No. / FF:Invalid	0xFF	x
0x0144	0	EEP_Ps4_PsType	PS Type 00:KME's PS (Group Page) / 01:KME's PS (Group Page/Message Waiting) 02:TD-7500 or TD-7590 / FF:Another Maker's PS	0xFF	x
0x0145	0	EEP_Ps4_lptui	PS ID IPUI (14Byte)	0x00, 0x00, 0x00, 0x00, 0x00, 0x00, 0x00, 0x00, 0x00, 0x00, 0x00, 0x00, 0x00, 0x00	x
0x018A	0	EEP_Ps5_InUseFlag	IN-Use Flag 00:Invalid / 01:Valid	0x00	x
0x018B	0	EEP_Ps5_DectPsNo	DECT PS No. 00-3F:PS No. / FF:Invalid	0xFF	x
0x018C	0	EEP_Ps5_PsType	PS Type 00:KME's PS (Group Page) / 01:KME's PS (Group Page/Message Waiting) 02:TD-7500 or TD-7590 / FF:Another Maker's PS	0xFF	x
0x018D	0	EEP_Ps5_lptui	PS ID IPUI (14Byte)	0x00, 0x00, 0x00, 0x00, 0x00, 0x00, 0x00, 0x00, 0x00, 0x00, 0x00, 0x00, 0x00, 0x00	x
0x0D07	3	EEP_System Password	System Password	0x00, 0x00	x

23.3.3. Flash Time Setting

Address	Initial Type	Name	Description	Default value	Country Setting
0x034D	1	EEP_FlashTime1	Calibrated loop-break time for "80 ms" Unit: 10 ms, defaults to 80 ms	0x08	x
0x034E	1	EEP_FlashTime2	Calibrated loop-break time for "90 ms" Unit: 10 ms, defaults to 90 ms	0x09	x

Address	Initial Type	Name	Description	Default value	Country Setting
0x034F	1	EEP_FlashTime3	Calibrated loop-break time for "100 ms" Unit: 10 ms, defaults to 100 ms	0x0A	x

23.3.4. Clip (Caller ID) configuration

Address	Initial Type	Name	Description	Default value	Country Setting
0x0227	1	EEP_ClipDetectConfig	CLIP detect configuration Bit0-2:Mode...1:DTMF only, 2:FSK only, 3:FSK/DTMF both, 4:Russian CLIP Bit3:Onhook...1=enable, 0=disable Bit4:Offhook...1=enable, 0=disable Bit5:MsgWaiting...1=enable, 0=disable Bit6:KpnVmwi...1=enable, 0=disable Bit7:Unused	0x3B	0x3C
0x0228	1	EEP_FskInterdigitTimeout	FSK Interdigit timeout Unit: 10ms, Defalut: 80ms	0x08	x
0x0229	1	EEP_RuClipReqLev	RCID REQ signal Level Default: -4.3dBm	0x00, 0x13	x
0x0383	1	EEP_ClipRingConfig	Ring configuration Bit0:Rpas...1=enable, 0=disable Bit1:RpasAlert...1=enable, 0=disable Bit2:Rpas2LongAlert...1=enable, 0=disable Bit3:Suppress1stRing...1=enable, 0=disable Bit4:Check1stRing...1=enable, 0=disable Bit5:RingEarlier...1=enable, 0=disable Bit6-7:Unused	0x20	x
0x0384	1	EEP_ImpSetConfig	Impedance Set configuration Bit0:Polarity...1=enable, 0=disable Bit1:Dtas...1=enable, 0=disable Bit2:Rpas...1=enable, 0=disable Bit3:PowerRing...1=enable, 0=disable Bit4:LearnImpPattern...1=enable, 0=disable Bit5:CheckPolStatus...1=enable, 0=disable Bit6-7: Unused	0x15	x
0x0385	1	EEP_ImpRemConfig	Impedance Remove configuration Bit0:Polarity...1=enable, 0=disable Bit1:Ringing...1=enable, 0=disable Bit2:ClipReceived...1=enable, 0=disable Bit3:Offhook...1=enable, 0=disable Bit4:ChszDet...1=enable, 0=disable Bit5-7:Unused	0x0F	x
0x0386	1	EEP_CasAckDtmf	CAS Acknowledge DTMF tone 00:DTMF 0 - 09:DTMF 9 0A:DTMF A 0B:DTMF B 0C:DTMF C 0D:DTMF D 0E:DTMF ✕ 0F:DTMF #	0x0D	x
0x0387	1	EEP_DtmfReceiveDataCount	Valid Receive data Count (for INDIA)	0x04	x
0x0388	1	EEP_ClipPhaseConfig	CLIP phase set configuration Bit0:ForwardNumber...1=enable, 0=disable Bit1:CallingNumber...1=enable, 0=disable Bit2:Dutch...1=enable, 0=disable Bit3:Chinese...1=enable, 0=disable Bit4:PriorityCheck...1=enable, 0=disable (for France) Bit5-6:AddZero...0:no add zero, 1:add zero absolutely 2:Check Number's top is zero. If it is zero, add zero. Bit7:TwDtmf...1=enable, 0=disable Bit8:FskRemoveParity...1=enable, 0=disable Bit9:AutoRappel...1=enable, 0=disable Bit10:KpnStartEndNg Bit11:CheckCidSendFlg Bit12:If DTMF CLIP come in series, 0:First data is available, 1:Last data is available Bit13-15:Unused	0x01, 0x04	x
0x038A	1	EEP_AddZeroDataCount	Valid data for Add Zero (for NewZealand)	0x05	x
0x038B	1	EEP_KpnVmwiConfig	CLIP RingVmwi set configuration Bit0:LongBellFuncOff...1=enable, 0=disable Bit1:StatusSucceed...1=enable, 0=disable Bit2-7:Unused	0x01	x
0x038C	1	EEP_RpasMinDuration	RPAS minimum duration Unit: 10ms, Default: 180ms	0x12	x

Address	Initial Type	Name	Description	Default value	Country Setting
0x038D	1	EEP_RpasMaxDuration	RPAS maximum duration Unit: 10ms, Default: 320ms	0x20	x
0x038E	1	EEP_DtasDataTimeout	DTAS to FSK data timeout Unit: 100ms, Default: 1s	0x0A	x
0x038F	1	EEP_ImpSetTimeout	Impedance Set timeout (RPAS for France) Unit: 10ms, Default: 250ms [Standard: 200-350ms]	0x14	x
0x0390	1	EEP_ImpRemRpasTimeout	Impedance Remove timeout (RPAS) Unit: 10ms, Default: 1250ms [Standard: 1450ms (subtract Impedance Set timeout)]	0x7D	x
0x0391	1	EEP_ImpRemChszTimeout	Impedance Remove timeout (Channel Seizure) Unit: 10ms, Default: 450ms [Standard: 420-570ms]	0x2D	x
0x0392	1	EEP_ImpRemContTimeout	Impedance Remove timeout Unit: 100ms, Default: 1s	0x0A	x
0x0393	1	EEP_CasAckDelayTimeout	CAS to Acknowledge DTMF Delay Timeout Unit: 1ms, Default: 0ms	0x00	x
0x0394	1	EEP_CasAckDuration	Acknowledge DTMF tone duration Unit: 1ms, Default: 70ms	0x46	x
0x0395	1	EEP_CasAckDataTimeout	CAS to FSK data timeout Unit: 10ms, Default: 600ms	0x64	x
0x0396	1	EEP_FskMarkoutTimeout	FSK Markout timeout after FSK received Unit: 10ms, Default: 100ms	0x0A	x
0x0397	1	EEP_DtmfInterdigitTimeout	DTMF Interdigit timeout Unit: 10ms, Default: 500ms	0x32	x
0x0398	1	EEP_DtmfMuteTimeout	Mute timeout when OFFHOOK CLIP received (for DK) Unit: 100ms, Default: 5s	0x32	x
0x0399	1	EEP_DtmfBellWaitTimeout	Bell Wait timeout Unit: 100ms, Default: 10s	0x6E	x
0x039A	1	EEP_RingVmwiMinDuration	Bell Ring minimum duration (for KPN VoiceMail) Unit: 1s, Default: 14s	0x0E	x
0x039B	1	EEP_RingVmwiMaxDuration	Bell Ring maximum duration (for KPN VoiceMail) Unit: 1s, Default: 22s	0x16	x
0x039C	1	EEP_RingPulseMin	Bell Ring on minimum duration (for KPN VoiceMail) Unit: 10ms, Default: 600ms	0x3C	x
0x039D	1	EEP_VmwiRingInterdigitMax	Bell Ring Interdigit maximum (for KPN VoiceMail) Unit: 100ms, Default: 5000ms	0x32	x
0x039E	1	EEP_RuConfig	Russian CLIP Configuration Bit0:Unused Bit1:RuClipMode...1=Auto, 0=Manual Bit2:RuClipRbtOnOff...1=on, 0=off Bit3:CategoryNo.Display...1=on (T/A), 0=off (MP) Bit4-7:Unused	0x00	x
0x039F	1	EEP_RuClipBackTraceTimeout	Back Trace Start Timeout Unit: 10ms, Default: 600ms	0x3C	x
0x03A0	1	EEP_RuRcvDigitBeforeReq	Receive Digit Before REQ Default: 2digit	0x02	x
0x03A1	1	EEP_PseudoBellLength	Pseudo Bell/RBT Length Unit: 10ms, Default: 800ms	0x50	x
0x03A2	1	EEP_PseudeBellToRbtLen	Pseudo Bell to RBT/RBT to Pesude Bell Length Unit: 100ms, Default: 1200ms	0x0C	x
0x03A3	1	EEP_PseudoBellEndTimeout	Pseudo Bell End Timeout Unit: 1s, Default: 120s	0x78	x
0x03A4	1	EEP_DtasMinDuration	DTAS minimum duration Unit: 10ms, Default: 60ms	0x06	x
0x03A5	1	EEP_DtasMaxDuration	DTAS maximum duration Unit: 10ms, Default: 130ms	0x0D	x
0x03A6	1	EEP_CasMinDuration	CAS minimum duration Unit: 10ms, Default: 60ms	0x06	x
0x03A7	1	EEP_CasMaxDuration	CAS maximum duration Unit: 10ms, Default: 130ms	0x0D	x
0x03A8	1	EEP_DtmfMinDuration	DTMF minimum duration Unit: 10ms, Default: 20ms	0x02	x
0x03A9	1	EEP_DtmfMaxDuration	DTMF maximum duration Unit: 10ms, Default: disable(0xFF)	0xFF	x

Address	Initial Type	Name	Description	Default value	Country Setting
0x03AA	1	EEP_RuDtmfDurationMin	RU_DTMF minimum duration Unit: 10ms, Default: 10ms	0x01	x
0x03AB	1	EEP_RuDtmfDurationMax	RU_DTMF maximum duration Unit: 10ms, Default: 70ms	0x07	x
0x03AC	1	EEP_RuDtmfDurationOff	RU_DTMF Off duration Unit: 10ms, Default: 50ms	0x05	x
0x0D01	3	EEP_RuClipReqLength	Length of REQ signal Unit: 10ms, Default: 140ms	0x0E	x
0x0D02	3	EEP_RuClipDelayBetweenReq	Delay between REQ signal Unit: 10ms, Default: 200ms	0x14	x
0x0D03	3	EEP_RuClipRepeatReq	Number of repeat REQ request Sent Default: 3 repeat	0x03	x
0x0D04	3	EEP_RuClipDelayBeforeReq	Delay before Send REQ signal Unit: 10ms, Default: 200ms	0x14	x
0x0D05	3	EEP_RuClipOnOff	Russian CLIP On/Off	0x01	x
0x0D06	3	EEP_RuClipRingNumBeforeSequence	Number Of Rings Patterns Before Start Sequence Default: 1	0x01	x
0x0D31	3	EEP_RuClipDisplayDigit	Number Of digits to be displayed Default: 7 digits	0x07	x

24 EEPROM LAYOUT (HANDSET)

24.1. Scope

The purpose of this section is to describe the layout of the EEPROM (IC10) for the KX-TCA132/TCA130 Handset.

The EEPROM contains hardware, software, and user specific parameters. Some parameters are set during production of the handset, some are set by the user when configuring the handset, and some during normal use of the phone.

24.2. Introduction

The handset uses a 64k bit serial EEPROM (IC10) for storing volatile parameters. All parameters are set up before the handset the factory. Some of these are vital for the operation of the hardware so a set of default parameters is programmed before the actual hardware fine-tuning can be initiated. This document lists all default settings with a short description.

This document lists all default parameters with a short description.

Initial Type	Description
F	The data initialized by only F command
0	The data initialized by F and 0 command
1	The data initialized by F, 0 and 1 command
2	The data initialized by F, 0, 1 and 2 command
3	The data initialized by all command (F, 0, 1, 2, 3)

Country Setting	Description
x	Default - no specific country setting, so revert to default value.

24.3. EEPROM contents

24.3.1. General Setup

Address	Initial Type	Name	Description	Default value	Country Setting
0x0001	F	EEP_FreqTrim_L	Setting value of FREQ_TRIM_REG	0x75	x
0x0002	F	EEP_BandGap	Setting value of BandGap REG	0x08	x
0x0010	-	EEP_lpei	International Portable Part Equipment Identities. A concatenation of an EMC and a unique 20 bit Serial Number.	0x00,0x00,0x00, 0x00,0x00	x
0x0182	1	EEP_LowQualityLevel	Signal quality level at which handover is initiated (CRC error count).	0x02	x
0x0189	1	EEP_RxMuteSyncError	Continuous SYNC error times for the Rx Mute (0-0xFF: Error times)	0x01	x
0x001D	0	EEP_HandsetNumber	HandsetNumber of Subscription0.	0xFF,0xFF	x
0x001F	0	EEP_HandsetNumber1	HandsetNumber of Subscription1.	0xFF,0xFF	x
0x0021	0	EEP_HandsetNumber2	HandsetNumber of Subscription2.	0xFF,0xFF	x
0x0023	0	EEP_HandsetNumber3	HandsetNumber of Subscription3.	0xFF,0xFF	x
0x0025	0	EEP_Subscription0	GAP Subscription Data. Storage for 4 subscriptions each with 53 bytes. <Subscription> 020 : SUB_boAssignedIPUI 021 : SUB_abIPUI[14] 02F : SUB_abPARK[5] 034 : SUB_abSARI[4] 038 : SUB_bPLI 039 : SUB_bLAL 03A : SUB_abARIplusRPN[5] 03F : SUB_boZAP 040 : SUB_bZAP 041 : SUB_boServiceClass 042 : SUB_bServiceClass 043 : AK_boUAKavailable 044 : AK_boUAKproven 045 : AK_abUAK_or_AC [16]	All 0x00	x
0x0340	3	EEP_HSPinCode	Handset Pin : 4 BCD Digits	0x00, 0x00	x

24.3.2. MMI Setting

Address	Initial Type	Name	Description	Default value	Country Setting
0x0195	1	EEP_FactoryLanguage Setting	Selected Language for LCD GERAM:0 ENGLISH:1 SPANISH:2 NORWEGIAN:3 FRENCH:4 ITALIAN:5 DENISH:6 DUTCH:7 SWEDISH:8 FINNISH:9 GREEK:10 TURKISH:11 HUNGARIAN:12 PORTUGUESE:13 RUSSIAN:14 POLISH:15 SLOVAKIAN:16 CZECH:17 CROATIAN:18 CATALAN:19	0x01	0x14
0x0196	1	EEP_Available_Language	Select Available Language 0:Disable, 1:Enable Bit0:German Bit1:English Bit2:Spanish Bit3:Norwegian Bit4:French Bit5:Italian Bit6:Danish Bit7:Dutch	0xFF	0x17
0x0197			Select Available Language 0:Disable, 1:Enable Bit0:Swedish Bit1:Finnish Bit2:Greek Bit3:Turkish Bit4:Hungarian Bit5:Portuguese Bit6:Russian Bit7:Polish	0x2F	0x40
0x0198			Select Available Language 0:Disable, 1:Enable Bit0:Slovakian Bit1:Czechs Bit2:Croatian Bit3:Catalan Bit4:Ukrinian Bit5:Spanish for Mexico Bit6:Slovenian Bit7:Estonian	0x08	0x10
0x0199			Select Available Language 0:Disable, 1:Enable Bit0:Lithuanian Bit1:Latvian Bit2:Romanian Bit3:Bulgarian Bit4:Seribian Bit5:Macedonian Bit6:Albanian Bit7:Reserve	0x00	x
0x0363	3	EEP_Language	User Setting Language GERAM:0 ENGLISH:1 SPANISH:2 NORWEGIAN:3 FRENCH:4 ITALIAN:5 DENISH:6 DUTCH:7 SWEDISH:8 FINNISH:9 GREEK:10 TURKISH:11 HUNGARIAN:12 PORTUGUESE:13 RUSSIAN:14 POLISH:15 SLOVAKIAN:16 CZECH:17 CROATIAN:18 CATALAN:19	0x01	0x14
0x0364	3	EEP_SmsEatoni Language	Eatoni Setting Language GERAM:0 ENGLISH:1 SPANISH:2 NORWEGIAN:3 FRENCH:4 ITALIAN:5 DENISH:6 DUTCH:7 SWEDISH:8 FINNISH:9 GREEK:10 TURKISH:11 HUNGARIAN:12 PORTUGUESE:13 RUSSIAN:14 POLISH:15 SLOVAKIAN:16 CZECH:17 CROATIAN:18 CATALAN:19	0x01	0x14
0x02BE	1	EEP_CountryFunction	Country parameter 0bit: Reset Ear-SP Vol. after Talk...0: Hold, 1: Reset 1bit: PBX Phone-Book...0: Enable, 1: Disable 2bit: Ringer Option Menu (Base Setting)...0: Off, 1: On 3-7bit: RESERVE	0x02	x

24.3.3. MMI1 Setting

Address	Initial Type	Name	Description	Default value	Country Setting
0x0102	1	EEP_DspSdtLevel	DSP Parameter SideTone2 Main:SideTone2 Main route level MictoRcv:SideTone2 Mic to Receiver level	0x00,0x0E	x
0x0104	1	EEP_DspToneLevel	DSP Parameter ToneLevel Talk:Tone Level in Talk mode Spp:Tone Level in Spp mode	0x00,0x20,0x00, 0x30	x
0x0108	1	EEP_DspRcvVol	DSP Parameter Receiver Volume TX Level TxTalk:Receiver Volume Tx Level in Talk mode TxSpp:Receiver Volume Tx Level in Spp mode	0xFF,0x7F	x
0x000E	F	EEP_LcdContrast	LCD contrast	0x20	x
0x0158	1	EEP_CountryFunction01	Country parameter Bit0:Call waiting Tone on/off...1:on, 0:off Bit1:Clock Back Up...1:on, 0:off Bit2:Charge ON Tone...1:Tone on, 0:KeyTone operating Bit3:BackUpTime revise...1:on, 0:off Bit4:On Charge Partial...1:none, 0:Partial Display Bit5:Start Talk Count Delay on/off...1:on, 0:off Bit6:Russian Model...1:Russian Model, 0:Not Russian Model Bit7:Reserve	0x3E	x
0x015B	3	EEP_EEToneConfig	Tone Option Data Bit0:Keytone on/off00 - 0000 = Off / 0001 = Tone On Bit1:Keytone on/off01 - Reserve Bit2:Keytone on/off02 - Reserve Bit3:Keytone on/off03 - Reserve Bit4:Call waiting on/off - 1/0 Bit5:Range alarm on/off - 1/0 Bit6:Battery low alarm on/off - 1/0	0x51	x

24.3.4. Battery Paramters

Address	Initial Type	Name	Description	Default value	Country Setting
0x0004	F	EEP_LowVoltage	ADC value for battery low detection	0x25	x
0x0005	F	EEP_NoVoltage	ADC value for shutdown voltage	0x08	x

25 HOW TO REPLACE THE FLAT PACKAGE IC

Even if you do not have the special tools (for example, a spot heater) to remove the Flat IC, with some solder (large amount), a soldering iron and a cutter knife, you can easily remove the ICs that have more than 100 pins.

25.1. PREPARATION

- PbF (: Pb free) Solder
- Soldering Iron

Tip Temperature of 700°F ± 20°F (370°C ± 10°C)

Note: We recommend a 30 to 40 Watt soldering iron. An expert may be able to use a 60 to 80 Watt iron where someone with less experience could overheat and damage the PCB foil.

- Flux

Recommended Flux: Specific Gravity → 0.82.

Type → RMA (lower residue, non-cleaning type)

Note: See **ABOUT LEAD FREE SOLDER (PbF: Pb free)** (P.4).

25.2. FLAT PACKAGE IC REMOVAL PROCEDURE

1. Put plenty of solder on the IC pins so that the pins can be completely covered.

Note:

If the IC pins are not soldered enough, you may give pressure to the P.C. board when cutting the pins with a cutter.

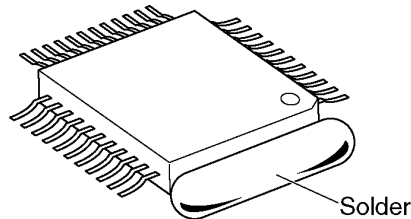

2. Make a few cuts into the joint (between the IC and its pins) first and then cut off the pins thoroughly.

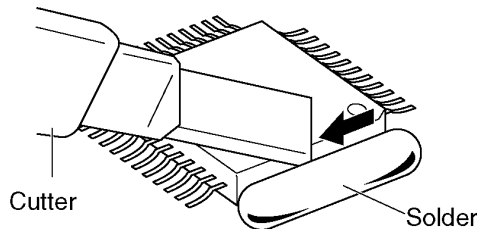

3. While the solder melts, remove it together with the IC pins.

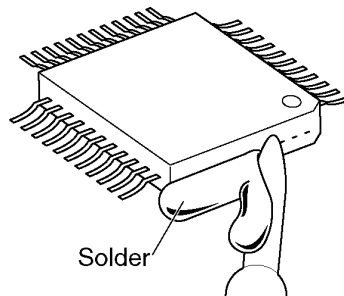

When you attach a new IC to the board, remove all solder left on the land with some tools like a soldering wire. If some solder is left at the joint on the board, the new IC will not be attached properly.

25.3. FLAT PACKAGE IC INSTALLATION PROCEDURE

1. Temporarily fix the FLAT PACKAGE IC, soldering the two marked pins.

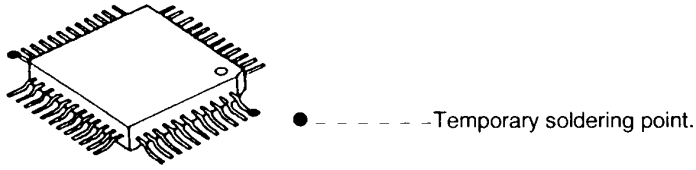

*Check the accuracy of the IC setting with the corresponding soldering foil.

2. Apply flux to all pins of the FLAT PACKAGE IC.

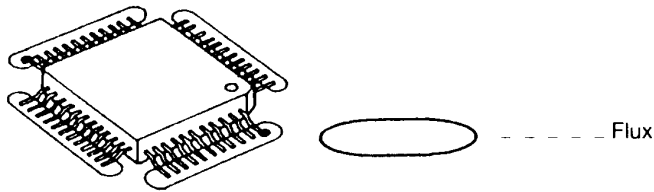

3. Solder the pins, sliding the soldering iron in the direction of the arrow.

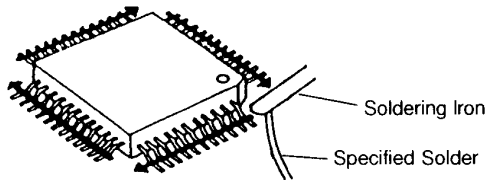

25.4. BRIDGE MODIFICATION PROCEDURE



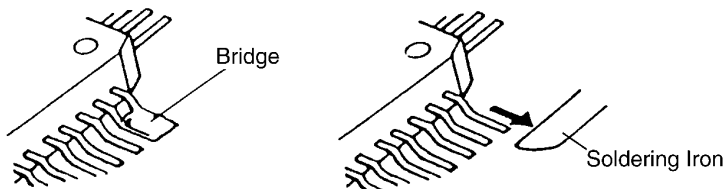

1. Lightly resolder the bridged portion.

2. Remove the remaining solder along the pins using a soldering iron as shown in the figure below.

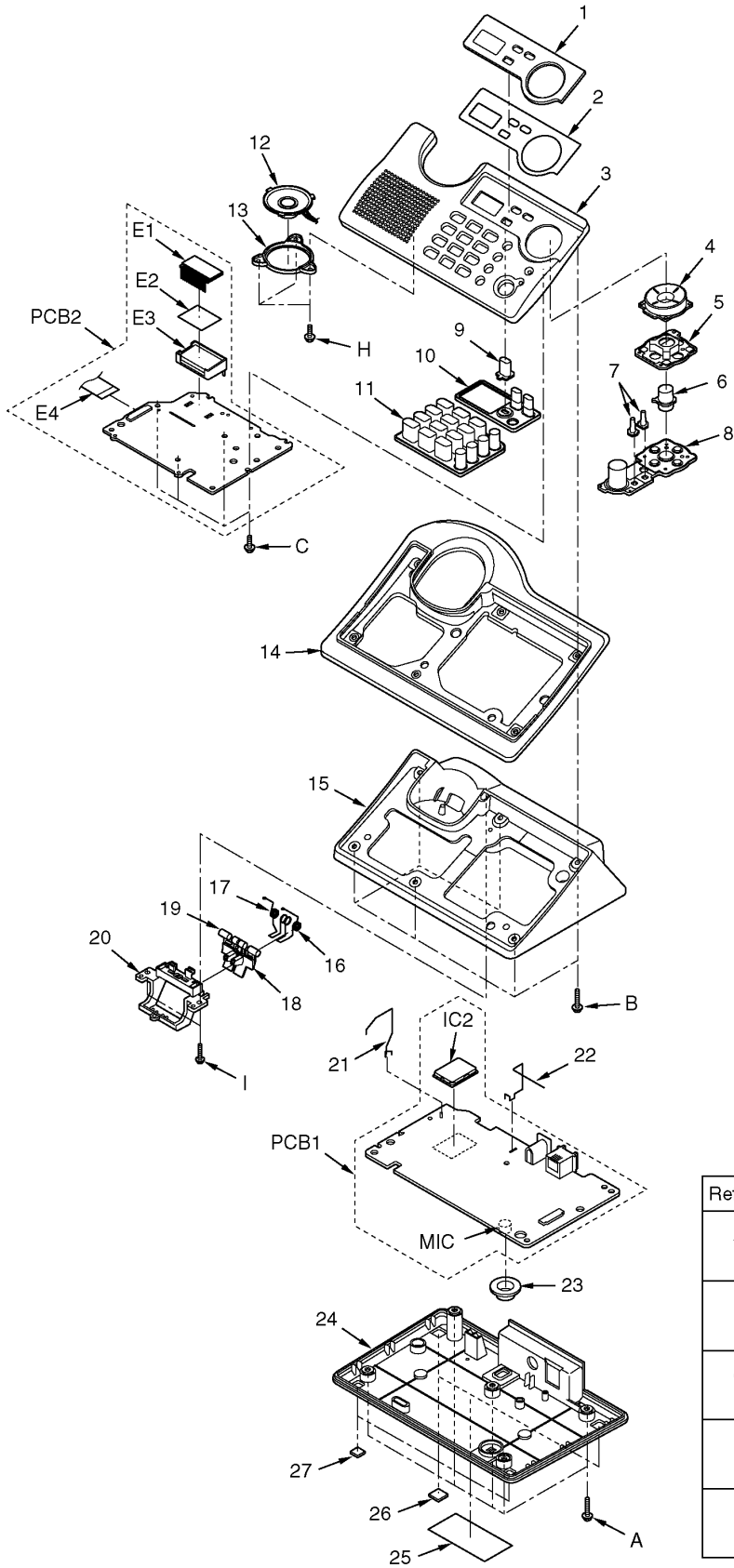





26 CABINET AND ELECTRICAL PARTS (BASE UNIT)

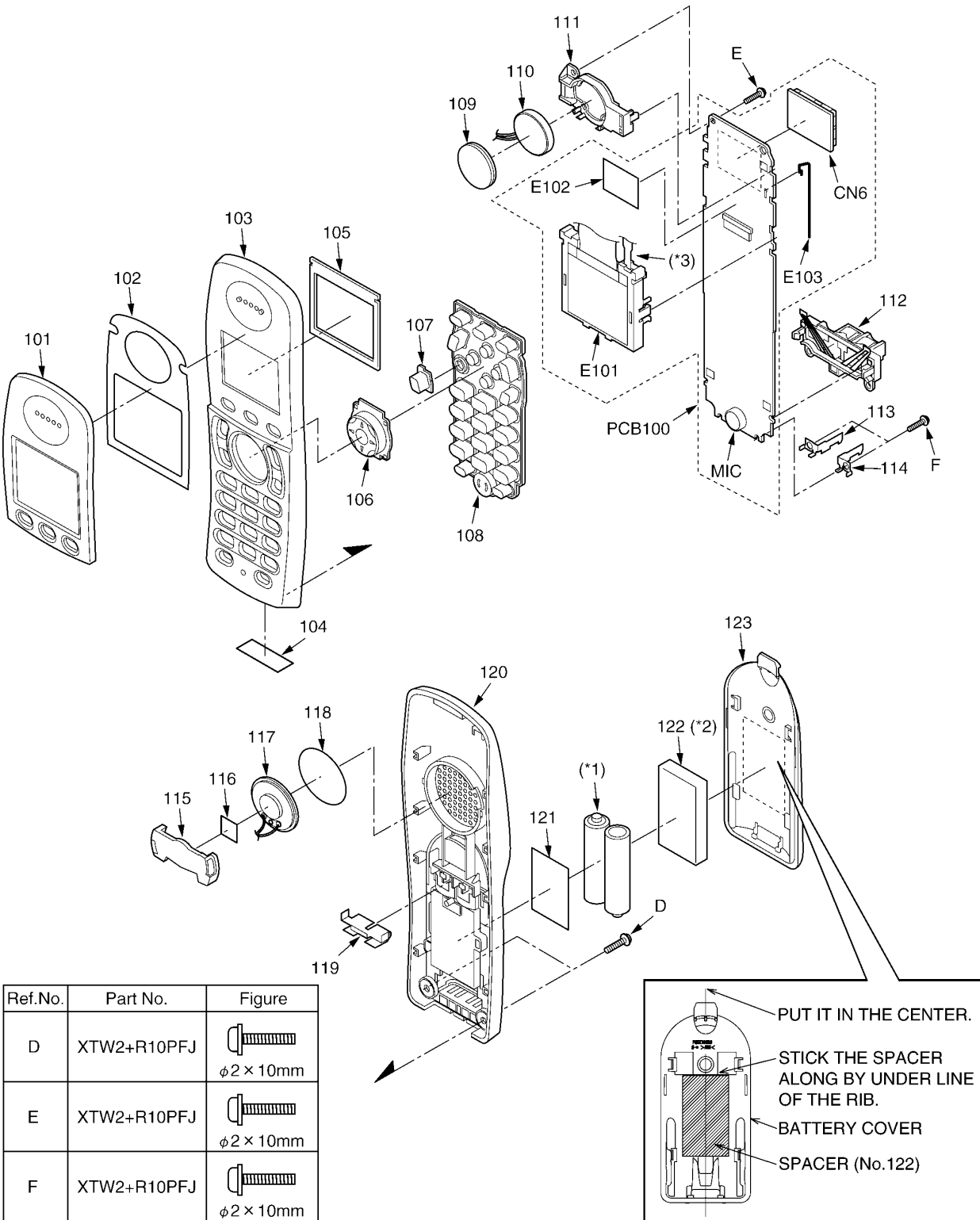

Ref.No.	Part No.	Figure
A	XTW26+14PFJ7	 φ2.6 × 14mm
B	XTW26+14PFJ7	 φ2.6 × 14mm
C	XTW26+8PFJ7	 φ2.6 × 8mm
H	XTW26+8PFJ7	 φ2.6 × 8mm
I	XTW26+14PFJ7	 φ2.6 × 14mm

27 CABINET AND ELECTRICAL PARTS (HANDSET)





Ref.No.	Part No.	Figure
D	XTW2+R10PFJ	 φ2×10mm
E	XTW2+R10PFJ	 φ2×10mm
F	XTW2+R10PFJ	 φ2×10mm

Note:

- (*1) The rechargeable Ni-MH battery P03P (HHR-4EPT) is available through sales route of Panasonic.
- (*2) Attach the spacer (No. 122) to the exact location described above.
- (*3) This cable is fixed by soldering. Refer to step ⑤ of **Fix the LCD to the Main P.C.Board (Handset)** (P.17).

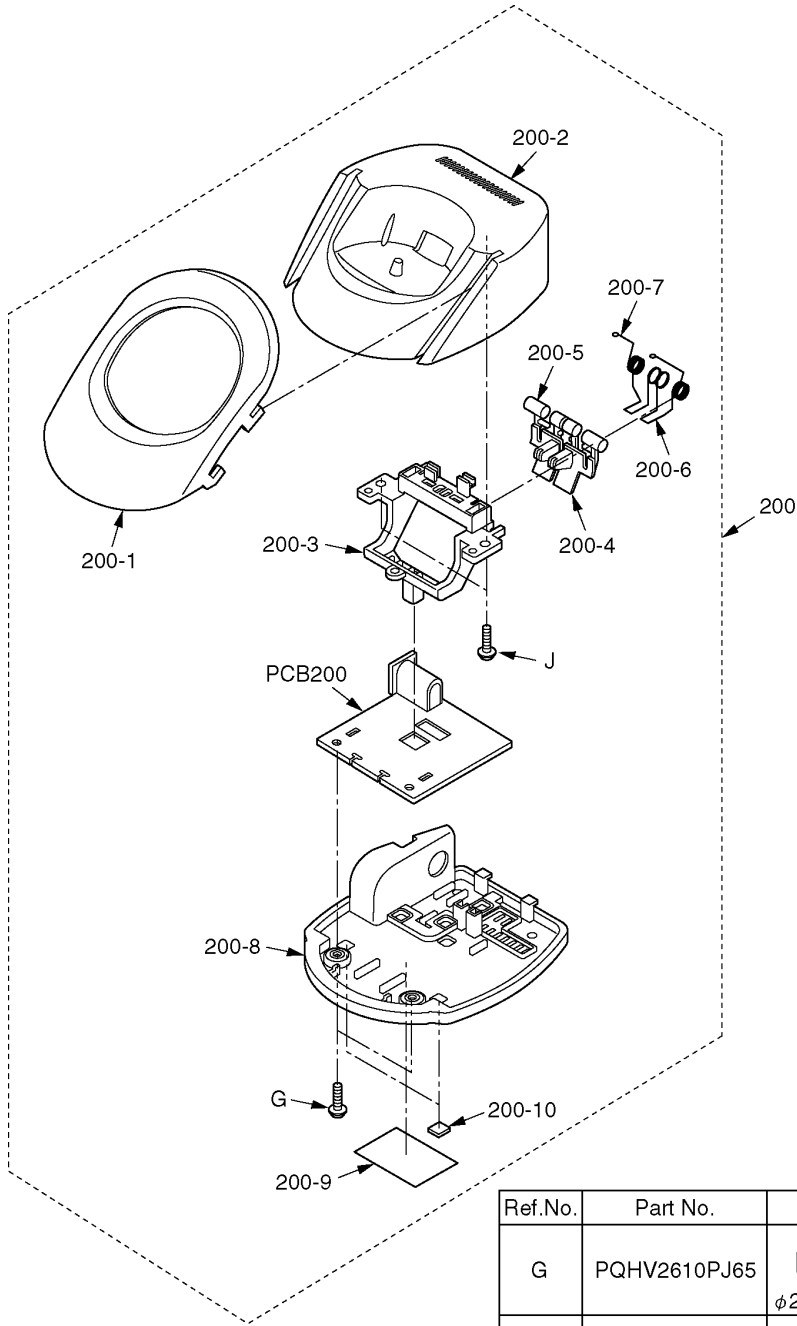
28 CABINET AND ELECTRICAL PARTS (CHARGER UNIT)



Ref.No.	Part No.	Figure
G	PQHV2610PJ65	 φ2.6 × 10mm
J	PQHV2610PJ65	 φ2.6 × 10mm

29 ACCESSORIES AND PACKING MATERIALS

29.1. KX-TCD346UAS/UAT

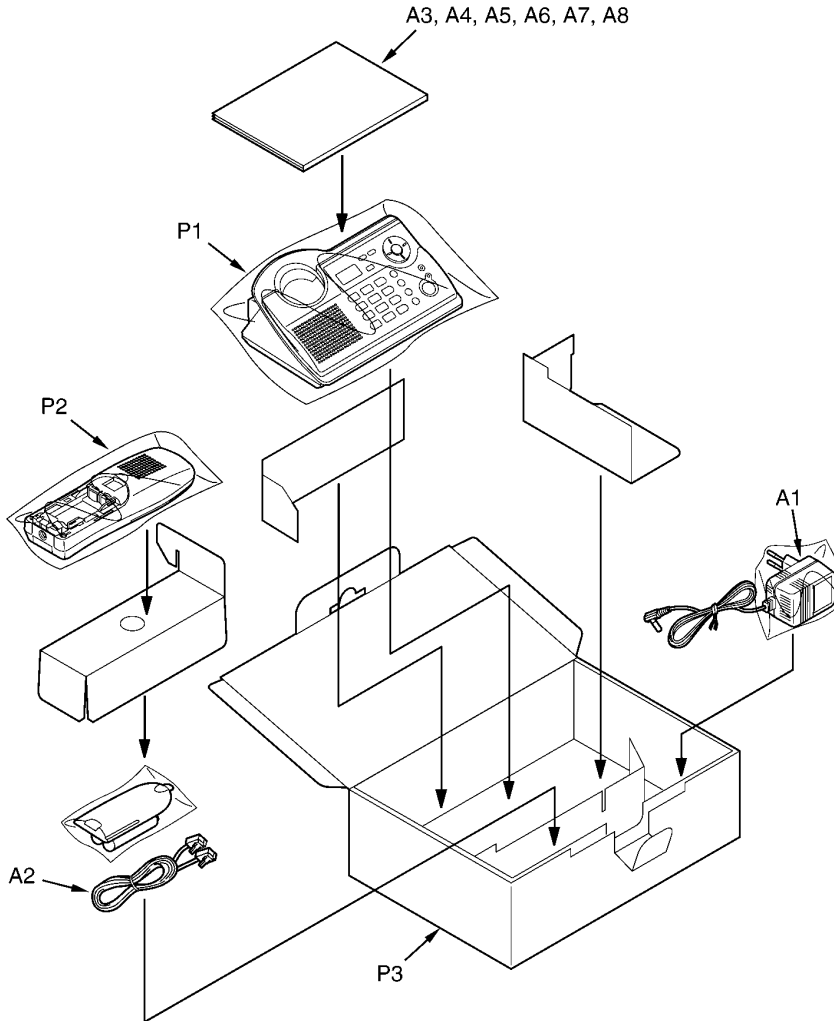

29.2. KX-TCA130UAS/UAT

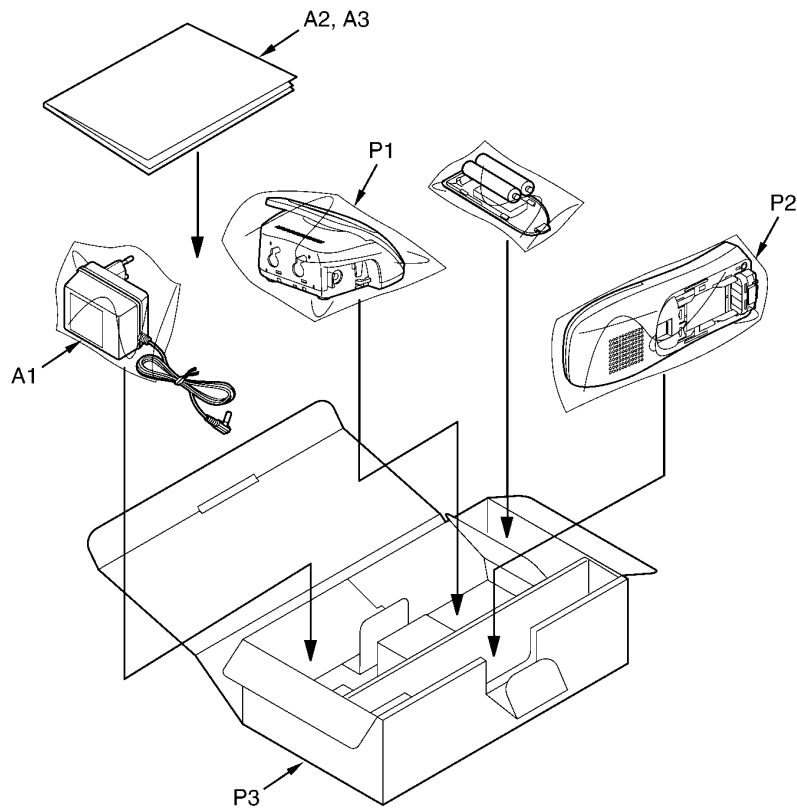

30 TERMINAL GUIDE OF THE ICs, TRANSISTORS AND DIODES

30.1. Base Unit

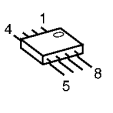
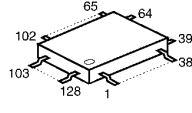
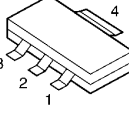
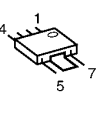
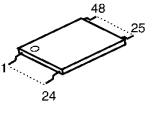
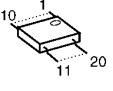
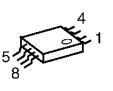
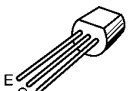
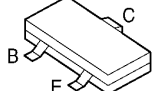
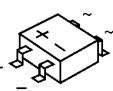
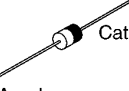
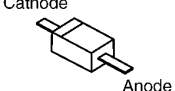
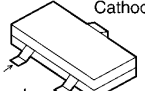
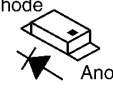
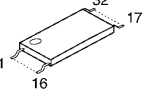
 PQWID300NEHR	 C1CB00002180	 C0CBAYF00016	 C0DBZGE00007	 PQWI3D346UAH
 C0JBAF000223	 C1BB00000265	 B1ACGP000007 B1AAJC000010	 PQVTBF822T7, B1ADGE000004 B1ABCF000103, 2SB1218A PQVTDTC143E	
 PQVDS1ZB60F1	 B0JAME000095	 Cathode Anode MA8047, B0JCDD000002, MA112 B0ECKM000008, MA1Z300, MA8220 B1ABCE000009		 B0DDCM000001
 LNJ308G8JRA PQVDBR1111C	 PQWI2D346UAH			

30.2. Handset

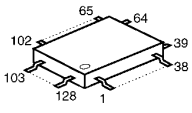
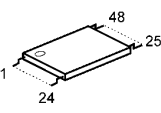
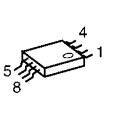
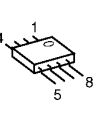
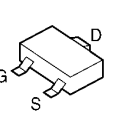
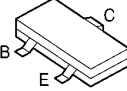
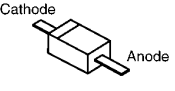
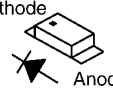
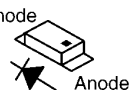
 C1CB00001830	 PQWI1A130UAR	 C1BB00000265	 PQWIA130EXRR	 PQVTFDN335N
 PSVTDTTC143X, B1ABGE000006 UN9219J, B1ADGE000004 B1ABCF000103		 Cathode Anode B0BC2R1A0006, MA8047 B0JCDD000002, MA2Z72000 B0JCME000035, MA111		 LNJ308G8JRA
 PQVDBR1111C				

30.3. Charger Unit

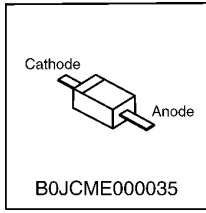

31 REPLACEMENT PARTS LIST

1. RTL (Retention Time Limited)

Note:

The marking (RTL) indicates that the Retention Time is limited for this item.

After the discontinuation of this assembly in production, the item will continue to be available for a specific period of time. The retention period of availability is dependant on the type of assembly, and in accordance with the laws governing part and product retention. After the end of this period, the assembly will no longer be available.

2. Important safety notice

Components identified by the Δ mark indicates special characteristics important for safety. When replacing any of these components, only use specified manufacture's parts.

3. The S mark means the part is one of some identical parts. For that reason, it may be different from the installed part.

4. ISO code (Example: ABS-94HB) of the remarks column shows quality of the material and a flame resisting grade about plastics.

5. RESISTORS & CAPACITORS

Unless otherwise specified;

All resistors are in ohms (Ω) K=1000 Ω , M=1000k Ω

All capacitors are in MICRO FARADS (μ F)P= μ F

*Type & Wattage of Resistor

Type

ERC:Solid ERDS:Carbon ERJ:Chip	ERX:Metal Film ERG:Metal Oxide ER0:Metal Film	PQ4R:Chip ERS:Fusible Resistor ERF:Cement Resistor
--------------------------------------	---	--

Wattage

10,16:1/8W	14,25:1/4W	12:1/2W	1:1W	2:2W	3:3W
------------	------------	---------	------	------	------

*Type & Voltage Of Capacitor

Type

ECFD:Semi-Conductor ECQS:Styrol ECUV,PQCUV,ECUE:Chip ECQMS:Mica	ECCD,ECKD,ECBT,F1K,ECUV: Ceramic ECQE,ECQV,ECQG: Polyester ECEA,ECST,EEE: Electlytic ECQP: Polypropylene
--	---

Voltage

ECQ Type	ECQG ECQV Type	ECSZ Type	Others		
1H:50V 2A:100V 2E:250V 2H:500V	05:50V 1:100V 2:200V	0F:3.15V 1A:10V 1V:35V 0J:6.3V	0J :6.3V 1A :10V 1C :16V 1E,25:25V	1V :35V 50,1H:50V 1J :16V 2A :100V	

Ref. No.	Part No.	Part Name & Description	Remarks
6	PQBC10430Z1	BUTTON, PLAY	ABS-HB
7	PQHR11124Z	OPTIC CONDUCTIVE PARTS, LED LENDS	PS-HB
8	PQSX10291Z	KEYBOARD SWITCH, 6 KEY	
9	PQBC10431Z1	BUTTON, ANSWER ON	ABS-HB
10	PQSX10293Z	KEYBOARD SWITCH, TAM KEY (for KX-TCD346UAS)	
10	PQSX10293Y	KEYBOARD SWITCH, TAM KEY (for KX-TCD346UAT)	
11	PQSX10292Z	KEYBOARD SWITCH, 16 KEY (for KX-TCD346UAS)	
11	PQSX10292Y	KEYBOARD SWITCH, 16 KEY (for KX-TCD346UAT)	
12	L0AA04A00028	SPEAKER	
13	PQHR11082Z	GUIDE, SPEAKER	POM-HB
14	PQGG10294Z1	GRILLE, CLEAR (for KX-TCD346UAS)	PC-HB
14	PQGG10294Z2	GRILLE, CLEAR (for KX-TCD346UAT)	PC-HB
15	PQKM10685Y1	CABINET BODY (for KX-TCD346UAS)	PS-HB
15	PQKM10685Y2	CABINET BODY (for KX-TCD346UAT)	PS-HB
16	PQJT10218Y	CHARGE TERMINAL (R)	
17	PQJT10219Y	CHARGE TERMINAL (L)	
18	PQKE10384Z3	HOLDER, CHARGE TERMINAL (R)	POM-HB
19	PQKE10385Z3	HOLDER, CHARGE TERMINAL (L)	POM-HB
20	PQHR11126Z	CASE, CHARGE TERMINAL	
21	PQSA10164Z	ANTENNA (L)	
22	PQSA10165Z	ANTENNA (R)	
23	PQMG10025Z	RUBBER PARTS, MIC	
24	PQKF10676Z1	CABINET COVER (for KX-TCD346UAS)	PS-HB
24	PQKF10676Z2	CABINET COVER (for KX-TCD346UAT)	PS-HB
25	PQGT17992Z	NAME PLATE (for KX-TCD346UAS)	
25	PQGT17992X	NAME PLATE (for KX-TCD346UAT)	
26	PQHA10017Z	RUBBER PARTS, LEG CUSHION	
27	PQHA10018Z	RUBBER PARTS, FOOT CUSHION	

31.1.2. Main P.C.Board Parts

Note:

(*1) When replacing IC3 or IC4, data need to be written to it with PQZZTCD346UA. Refer to **Base Unit (P.41)** of **THINGS TO DO AFTER REPLACING IC**.

Ref. No.	Part No.	Part Name & Description	Remarks
PCB1	PQWP1D346UAH	MAIN P.C.BOARD ASS'Y (RTL) (ICs)	
IC1	C0DBZGE00007	IC	
IC3	PQWID300NEHR	IC (EEPROM) (*1)	
IC4	CLCB00002180	IC (BBIC) (*1)	
IC6	PQWI2D346UAH	IC (FLASH MEMORY)	
IC7	CLBB00000265	IC	
IC8	PQWI3D346UAH	IC (FLASH MEMORY)	
IC9	C0JBAF000223	IC	
IC10	C0JBAF000223	IC	
IC11	C0CBAYF00016	IC	
		(TRANSISTORS)	
Q2	BLADGE000004	TRANSISTOR (SI)	
Q3	BLADGE000004	TRANSISTOR (SI)	
Q4	BLACGP000007	TRANSISTOR (SI)	
Q5	PQVTFB822T7	TRANSISTOR (SI)	
Q6	BLABCF000103	TRANSISTOR (SI)	
Q7	BLABCF000103	TRANSISTOR (SI)	
Q8	BLAAJC000010	TRANSISTOR (SI)	
Q12	BLABCE000009	TRANSISTOR (SI)	
Q361	2SB1218A	TRANSISTOR (SI)	
Q362	PQVYDTC143E	TRANSISTOR (SI)	S
		(DIODES)	

31.1. Base Unit

31.1.1. Cabinet and Electrical Parts

Ref. No.	Part No.	Part Name & Description	Remarks
1	PQGF10286Z1	PANEL, LCD (for KX-TCD346UAS)	AS-HB
1	PQGF10286Z2	PANEL, LCD (for KX-TCD346UAT)	AS-HB
2	PQHS10675Z	TAPE, DOUBLE SIDED (LCD)	
3	PQGG10293Z1	GRILLE, FRONT (for KX-TCD346UAS)	PS-HB
3	PQGG10293Z2	GRILLE, FRONT (for KX-TCD346UAT)	PS-HB
4	PQBC10429Z1	BUTTON, NAVI KEY	ABS-HB
5	PQHR11125Z	GUIDE, NAVI KEY BUTTON	POM-HB

Ref. No.	Part No.	Part Name & Description	Remarks
D1	B0JAME000095	DIODE (SI)	
D3	PQVDSLZB60F1	DIODE (SI)	S
D4	MA1Z300	DIODE (SI)	S
D6	MA8220	DIODE (SI)	S
D7	MA112	DIODE (SI)	S
D8	B0JCDD000002	DIODE (SI)	
D301	MA8047	DIODE (SI)	S
D311	B0JCDD000002	DIODE (SI)	
D361	B0ECKM000008	DIODE (SI)	
DA1	B0DDCM000001	DIODE (SI)	
		(COILS)	
L3	PQLQR2M33NKT	COIL	S
L5	PQLQR2M6N8KT	COIL	S
L6	PQLQXF330K	COIL	S
L7	PQLQXF330K	COIL	S
L8	PQLQR2M6N8KT	COIL	S
L12	ELJPA6R8MF	COIL	
L13	G1C100MA0072	COIL	
L14	G1C100MA0072	COIL	
		(JACKS AND CONNECTOR)	
CN1	PQJJ1TA15Z	JACK	S
CN2	PQJJ1B4Y	JACK	S
CN6	K1MN30B00031	CONNECTOR	
		(LCR FILTERS)	
R60	J0JCC0000277	LCR FILTER	
R63	J0JCC0000277	LCR FILTER	
R144	J0JCC0000277	LCR FILTER	
R145	J0JCC0000277	LCR FILTER	
R156	J0JCC0000277	LCR FILTER	
R304	J0JCC0000309	LCR FILTER	
R308	J0JCC0000277	LCR FILTER	
		(COMPONENTS PARTS)	
RA1	EXB28V222JX	RESISTOR ARRAY	
RA2	EXB28V222JX	RESISTOR ARRAY	
RA3	D1H810240004	RESISTOR ARRAY	S
RA4	EXB28V101JX	RESISTOR ARRAY	
RA5	EXB28V101JX	RESISTOR ARRAY	
RA6	EXB28V101JX	RESISTOR ARRAY	
RA7	EXB28V101JX	RESISTOR ARRAY	
		(VARISTORS)	
SA1	J0LF00000026	VARISTOR (SURGE ABSORBER)	
SA2	PQVDDSS301L	VARISTOR (SURGE ABSORBER)	S
		(RESISTORS)	
R2	ERJ1WYJ220	22	
R4	ERJ1WYJ220	22	
R5	ERJ3GEYJ562	5.6K	
R6	ERJ3GEYJ153	15K	
R10	ERJ3GEYJ221	220	
R11	ERJ3GEYJ221	220	
R16	ERJ3GEYJ105	1M	
R17	ERJ3GEYJ105	1M	
R18	ERJ3EKF5601	5.6K	
R19	ERJ3EKF2401	2.4K	
R22	ERJ3GEYJ104	100K	
R23	ERJ3GEYJ104	100K	
R24	ERJ3GEYJ101	100	
R25	PQ4R10XJ272	2.7K	S
R26	ERJ3GEYJ103	10K	
R27	ERJ3GEYJ104	100K	
R28	ERJ3GEYJ222	2.2K	
R32	ERJ3GEYJ101	100	
R33	ERJ3GEYJ473	47K	
R34	ERJ3GEYJ103	10K	
R35	ERJ2GEJ104	100K	
R38	ERJ3GEYJ184	180K	
R39	ERJ3GEYJ560	56	
R40	ERJ3GEYJ335	3.3M	
R41	ERJ3GEYJ101	100	
R42	ERJ3GEYJ273	27K	
R43	ERJ3GEYJ822	8.2K	
R44	ERJ3GEYJ222	2.2K	
R45	ERJ12YJ120	12	
R46	ERJ12YJ270	27	

Ref. No.	Part No.	Part Name & Description	Remarks
R47	ERJ3GEYJ104	100K	
R48	ERJ3GEYJ473	47K	
R49	ERJ3GEYJ560	56	
R51	ERJ3GEYJ103	10K	
R52	ERJ3GEYJ471	470	
R54	ERJ3GEYJ821	820	
R55	ERJ3GEYJ473	47K	
R56	ERJ3GEYJ103	10K	
R57	ERJ3GEYJ103	10K	
R61	ERJ2GEJ181	180	
R62	ERJ2GEJ102	1K	
R64	ERJ2GEJ684	680K	
R65	ERJ2GEJ103	10K	
R69	ERJ3GEYJ104	100K	
R70	ERJ3GEYJ104	100K	
R71	ERJ3GEYJ104	100K	
R72	ERJ3GEYJ474	470K	
R73	ERJ3GEYJ101	100	
R74	ERJ3GEYJ102	1K	
R75	ERJ3GEYJ101	100	
R76	ERJ3GEYJ102	1K	
R77	ERJ3GEYJ103	10K	
R79	ERJ3GEYJ681	680	
R80	PQ4R18XJ100	10	S
R81	ERJ8GEYJ123	12K	
R82	ERJ3GEYJ103	10K	
R85	ERJ3GEY0R00	0	
R86	ERJ3GEY0R00	0	
R87	ERJ3GEY0R00	0	
R88	ERJ3GEY0R00	0	
R89	ERJ3GEY0R00	0	
R90	ERJ3GEY0R00	0	
R91	ERJ3GEYJ103	10K	
R92	ERJ3GEYJ103	10K	
R96	ERJ2GEJ104	100K	
R97	ERJ2GEJ104	100K	
R105	ERJ3GEYJ103	10K	
R106	ERJ3GEYJ184	180K	
R107	ERJ3GEYJ184	180K	
R117	ERJ2GEJ102	1K	
R118	ERJ3GEYJ181	180	
R119	ERJ3GEYJ181	180	
R123	ERJ2GE0R00	0	
R125	ERJ2GEJ820	82	
R127	ERJ2GEJ101	100	
R128	ERJ2GEJ472X	4.7K	
R129	ERJ2GEJ102	1K	
R130	ERJ2GEJ472X	4.7K	
R131	ERJ2GEJ102	1K	
R132	ERJ2GE0R00	0	
R134	ERJ2GEJ472X	4.7K	
R135	ERJ2GEJ102	1K	
R136	ERJ2GEJ472X	4.7K	
R137	ERJ2GEJ391	390	
R140	ERJ2GEJ391	390	
R141	ERJ2GEJ391	390	
R142	ERJ2GEJ391	390	
R143	ERJ2GEJ391	390	
R146	ERJ2GEJ103	10K	
R147	ERJ2GEJ391	390	
R148	ERJ2GEJ391	390	
R149	ERJ2GEJ391	390	
R150	ERJ2GEJ391	390	
R151	ERJ2GEJ391	390	
R152	ERJ2GEJ391	390	
R153	ERJ2GEJ391	390	
R154	ERJ3GEY0R00	0	
R155	ERJ3GEY0R00	0	
R157	ERJ2GEJ222	2.2K	
R158	ERJ2GEJ222	2.2K	
R159	ERJ2GEJ104	100K	
R160	ERJ2GEJ104	100K	
R162	ERJ2GEJ273X	27K	

Ref. No.	Part No.	Part Name & Description	Remarks
R163	ERJ2GEJ273X	27K	
R164	ERJ2GEJ273X	27K	
R301	ERJ3GEYJ331	330	
R302	ERJ3GEYJ222	2.2K	
R303	ERJ3GEYJ330	33	
R305	ERJ3GEYJ330	33	
R306	ERJ3GEYJ471	470	
R307	ERJ3GEYJ471	470	
R311	ERJ3GEYJ154	150K	
R312	ERJ3GEYJ101	100	
R314	ERJ3GEYJ393	39K	
R361	ERJ3GEYJ332	3.3K	
R362	ERJ3GEYJ103	10K	
R363	ERJ3GEYJ102	1K	
R365	ERJ2GEJ102	1K	
R366	ERJ2GEJ102	1K	
R367	ERJ2GEJ102	1K	
R368	ERJ2GEJ102	1K	
R369	ERJ2GEJ102	1K	
R370	ERJ2GEJ102	1K	
R371	ERJ2GE0R00	0	
R372	ERJ2GE0R00	0	
R373	ERJ2GE0R00	0	
R374	ERJ2GE0R00	0	
R375	ERJ8GEY0R00	0	
R376	ERJ3GEYJ102	1K	
D14	ERJ8GEY0R00	0	
D15	ERJ8GEY0R00	0	
J10	ERJ3GEY0R00	0	
L4	ERJ3GEY0R00	0	
L9	ERJ3GEY0R00	0	
L10	ERJ3GEY0R00	0	
L11	ERJ3GEYJ100	10	
		(CAPACITORS)	
C1	ECUV1H100DCV	10P	
C2	ECEA1EU101	100	S
C3	ECEA0JU331	330	S
C4	ECUV1H100DCV	10P	
C6	ECUE1H471KBQ	470P	S
C7	ECEA1CK101	100	S
C8	ECUV1H100DCV	10P	
C9	ECUV1H100DCV	10P	
C10	ECEA1AU101	100	S
C11	ECUV1H040CCV	4P	
C12	F1B2H152A048	0.0015	
C13	F1B2H152A048	0.0015	
C14	ECKD2H681KB	680P	S
C15	ECKD2H681KB	680P	S
C17	ECJ1VB1H221K	220P	
C21	ECUV1H100DCV	10P	
C22	ECJ1VB1H221K	220P	
C23	ECUV1H100DCV	10P	
C24	PQCUV1C104KB	0.1	
C25	ECEA1AU101	100	S
C26	ECUV1H100DCV	10P	
C27	ECUV1H100DCV	10P	
C28	ECEA0JKA331	330	
C30	ECEA1AKA221	220	
C32	ECUV1E223KBV	0.022	
C36	ECJ1VB1H472K	0.0047	
C38	ECUV1C823KBV	0.082	
C40	PQCUV1A225KB	2.2	
C41	PQCUV1C224KB	0.22	
C42	ECUV1H300JCV	30P	
C43	ECUV1H120JCV	12P	
C45	ECUV1H100DCV	10P	
C46	PQCUV1A105KB	1	
C47	PQCUV1C224KB	0.22	
C48	ECUV1C104KBV	0.1	
C49	ECEA1HKA100	10	
C50	PQCUV1H104ZF	0.1	S
C51	ECUV1H100DCV	10P	
C53	ECUV1C104KBV	0.1	

Ref. No.	Part No.	Part Name & Description	Remarks
C54	ECUV1C224KBV	0.22	
C55	ECUV1C683KBV	0.068	
C56	ECUV1H100DCV	10P	
C57	ECUV1H101JCV	100P	
C58	ECUV1C104KBV	0.1	
C69	ECUV1C104KBV	0.1	
C70	ECUV1C683KBV	0.068	
C71	ECUV1C104KBV	0.1	
C74	ECUV1H103KBV	0.01	
C75	ECUV1H103KBV	0.01	
C76	ECUV1C473KBV	0.047	
C77	ECUV1C104KBV	0.1	
C79	ECUV1C104KBV	0.1	
C80	PSCUV2ET474K	0.47	S
C81	ECUV1C104KBV	0.1	
C82	ECUV1C104KBV	0.1	
C84	ECUV1C104KBV	0.1	
C86	ECUV1C104KBV	0.1	
C87	ECUV1C104KBV	0.1	
C88	ECUV1H101JCV	100P	
C89	ECUV1H101JCV	100P	
C90	ECUV1H101JCV	100P	
C101	ECUV1H102KBV	0.001	
C102	ECUV1H102KBV	0.001	
C103	ECUV1C104KBV	0.1	
C104	ECUV1H391JCV	390P	
C106	ECUV1C104KBV	0.1	
C107	ECUV1C104KBV	0.1	
C109	PQCUV1A105KB	1	
C130	ECUV1H100DCV	10P	
C136	ECUE1H102KBQ	0.001	S
C140	ECUV1H060DCV	6P	S
C141	ECUV1H060DCV	6P	S
C142	ECUV1H100DCV	10P	
C143	ECUV1H100DCV	10P	
C144	ECUV1H060DCV	6P	S
C147	ECUV1A475KB	4.7	
C151	ECUV1A475KB	4.7	
C153	ECUE1H220JCV	22P	S
C154	ECUE1H100DCQ	10P	S
C155	ECUE1H020CCQ	2P	S
C156	ECUE1H100DCQ	10P	S
C157	ECUE1H070DCQ	7P	S
C158	ECUE1H100DCQ	10P	S
C159	ECUE1H020CCQ	2P	S
C160	ECUE1H100DCQ	10P	S
C161	ECUE1H020CCQ	2P	S
C162	ECUE1H100DCQ	10P	S
C164	F1G1H151A541	150P	
C173	ECUV1H100DCV	10P	
C180	ECUV1H100DCV	10P	
C181	ECUV1H100DCV	10P	
C182	ECUV1H102KBV	0.001	
C301	ECUV1H100DCV	10P	
C302	ECUV1H100DCV	10P	
C303	ECUV1H100DCV	10P	
C304	ECEA0JU331	330	S
C305	ECUV1H821KBV	820P	
C306	ECUV1C104KBV	0.1	
C307	ECUV1H332KBV	0.0033	
C312	ECUV1H100DCV	10P	
C313	ECUV1C104KBV	0.1	
C314	ECJ1VB1H221K	220P	
C315	ECUV1H100DCV	10P	
C316	ECUV1H220JCV	22P	
C317	ECUV1A224KBV	0.22	
C319	ECUV1A224KBV	0.22	
C320	ECUV1C104KBV	0.1	
C322	ECUV1A105KBV	1	
C361	ECUV1H102KBV	0.001	
C362	ECUE1C103KBQ	0.01	S
C363	ECUV1H471JCV	470P	S
C364	ECUV1H152KBV	0.0015	

Ref. No.	Part No.	Part Name & Description	Remarks
C365	ECUV1H152KBV	0.0015	
C367	ECUV1H101JCV	100P	
C368	ECUE1H101JCQ	100P	S
		(OTHERS)	
MIC	L0CBAB000052	MICROPHONE	
IC2	PQLP10263Z	RF UNIT	
X1	HOD103500003	CRYSTAL OSCILLATOR	

31.1.3. Operational P.C.Board Parts

Ref. No.	Part No.	Part Name & Description	Remarks
PCB2	PQWP2D340EH	OPERATIONAL P.C.BOARD ASS'Y (RTL)	
		(TRANSISTORS)	
Q901	PQVTDTC143E	TRANSISTOR (SI)	S
Q902	PQVTDTC143E	TRANSISTOR (SI)	S
Q903	PQVTDTC143E	TRANSISTOR (SI)	S
		(DIODES)	
LED901	PQVDBR1111C	LED	S
LED902	LNJ308G8JRA	LED	
LED903	PQVDBR1111C	LED	S
		(RESISTORS)	
R901	ERJ3GEYJ561	560	
R902	ERJ3GEYJ820	82	
R903	ERJ3GEYJ181	180	
		(CONNECTOR)	
CN901	K1MN30B00031	CONNECTOR	
		(OTHERS)	
E1	L5DCBCB00017	LIQUID CRYSTAL DISPLAY	
E2	PQHS10327Z	TAPE, LCD	
E3	PQHR11102Z	GUIDE, LCD	PS-HB
E4	PQJE10145Z	LEAD WIRE, FFC	

31.2. Handset

31.2.1. Cabinet and Electrical Parts

Ref. No.	Part No.	Part Name & Description	Remarks
101	PQGP10265Y1	PANEL, LCD (for KX-TCA132UAS) (for KX-TCA130UAS)	AS-HB
101	PQGP10265Y3	PANEL, LCD (for KX-TCA132UAT) (for KX-TCA130UAT)	AS-HB
102	PQHS10673W	TAPE, DOUBLE SIDED	
103	PQKM10647V8	CABINET BODY (for KX-TCA132UAS)	ABS-HB
103	PQKM10647V0	CABINET BODY (for KX-TCA132UAT)	ABS-HB
103	PQKM10647Z1	CABINET BODY (for KX-TCA130UAS)	ABS-HB
103	PQKM10647Z3	CABINET BODY (for KX-TCA130UAT)	ABS-HB
104	PQGT18194Z	NAME PLATE (for KX-TCA132UAS MADE IN THAILAND)	
104	PQGT18194X	NAME PLATE (for KX-TCA132UAT MADE IN THAILAND)	
104	PQGT17428Z	NAME PLATE (for KX-TCA130UAS MADE IN CHINA)	
104	PQGT17428X	NAME PLATE (for KX-TCA130UAT MADE IN CHINA)	
105	PQHE10155Z	SPACER, LCD CUSHION	
106	PQBC10413Z1	BUTTON, NAVI KEY	ABS-HB
107	PQBC10414Y1	BUTTON, SP PHONE	ABS-HB
108	PQSX10274T	KEYBOARD SWITCH (for KX-TCA132UAS) (for KX-TCA130UAS)	
108	PQSX10274R	KEYBOARD SWITCH (for KX-TCA132UAT) (for KX-TCA130UAT)	
109	PQHS10467Z	COVER, SP NET	
110	L0AD02A00015	SPEAKER	
111	PQHR11104Z	GUIDE, SPEAKER	ABS-HB
112	PQWE10034Z	BATTERY TERMINAL	
113	PQJT10216Z	CHARGE TERMINAL (R)	
114	PQJT10217Z	CHARGE TERMINAL (L)	
115	PQHR11059Z	GUIDE, SPEAKER	ABS-HB

Ref. No.	Part No.	Part Name & Description	Remarks
116	PQHG10702Z	RUBBER PARTS, SPEAKER	
117	L0AD02A00010	SPEAKER	
118	PQHS10622Z	COVER, SP NET	
119	PQJC10056Y	BATTERY TERMINAL	
120	PQKF10630X1	CABINET COVER (for KX-TCA132UAS) (for KX-TCA130UAS)	ABS-HB
120	PQKF10630X3	CABINET COVER (for KX-TCA132UAT) (for KX-TCA130UAT)	ABS-HB
121	PQHX11353Z	PLASTIC PARTS, BATTERY COVER SHEET (for KX-TCA132UAS) (for KX-TCA132UAT)	
121	PQHX11311Y	PLASTIC PARTS, BATTERY COVER SHEET (for KX-TCA130UAS) (for KX-TCA130UAT)	
122	PQHS10561Y	SPACER, BATTERY COVER	
123	PQKK10583Z1	LID, BATTERY COVER (for KX-TCA132UAS) (for KX-TCA130UAS)	ABS-HB
123	PQKK10583Z3	LID, BATTERY COVER (for KX-TCA132UAT) (for KX-TCA130UAT)	ABS-HB

31.2.2. Main P.C.Board Parts

Note:

(*1) When replacing IC1 or IC10, data need to be written to them with PQZZTCD346UA. Refer to **Handset (P.41) of THINGS TO DO AFTER REPLACING IC** .

(*2) When replacing the Handset LCD, see **ASSEMBLY INSTRUCTIONS (P.17)**.

Ref. No.	Part No.	Part Name & Description	Remarks
PCB100	PQWPCD305UAR	MAIN P.C.BOARD ASS'Y (RTL) (for KX-TCD346UAS/UAT)	
PCB100	PQWPCA130UAR	MAIN P.C.BOARD ASS'Y (RTL) (for KX-TCA130UAS/UAT)	
		(ICs)	
IC1	C1CB00001830	IC (BBIC) (*1)	
IC2	C1BB00000265	IC	
IC10	PQWIA130EXRR	IC (EEPROM) (*1)	
IC11	PQWIA130UAR	IC (FLASH)	
		(TRANSISTORS)	
Q1	PQVTFDN335N	TRANSISTOR (SI)	S
Q2	BLADGE000004	TRANSISTOR (SI)	
Q3	BLADGE000004	TRANSISTOR (SI)	
Q4	BLADGE000004	TRANSISTOR (SI)	
Q5	BLABCF000103	TRANSISTOR (SI)	
Q9	UN9219J	TRANSISTOR (SI)	S
Q16	BLABGE000006	TRANSISTOR (SI)	
Q17	PSVTDTC143X	TRANSISTOR (SI)	S
Q18	PSVTDTC143X	TRANSISTOR (SI)	S
Q19	BLABCF000103	TRANSISTOR (SI)	
		(DIODES)	
D1	B0JCM000035	DIODE (SI)	
D4	MA8047	DIODE (SI)	S
D5	MA8047	DIODE (SI)	S
D6	B0BC2R1A0006	DIODE (SI)	
D7	MA2Z72000	DIODE (SI)	
D8	B0JCDD000002	DIODE (SI)	
D9	MA111	DIODE (SI)	S
LED4	LNJ308G8JRA	DIODE (SI)	
LED5	LNJ308G8JRA	DIODE (SI)	
LED6	LNJ308G8JRA	DIODE (SI)	
LED7	LNJ308G8JRA	DIODE (SI)	
LED9	PQVDBR1111C	DIODE (SI)	S
		(COILS)	
L1	G1C470M00025	COIL	
L4	G1C100MA0072	COIL	
L5	G1C100MA0072	COIL	
L6	G1C101M00007	COIL	
F1	PQLQR2M5N6K	COIL	S
		(RESISTORS)	
R1	ERJL06KJ47MV	0.047	
R2	ERJ3GEYF823	82K	
R3	ERJ3EKF1503	150K	

Ref. No.	Part No.	Part Name & Description	Remarks
R4	ERJ3GEYJ153	15K	
R5	ERJ3GEYJ471	470	
R6	ERJ3GEYJ103	10K	
R7	ERJ3GEYJ224	220K	
R9	ERJ3GEYJ562	5.6K	
R10	ERJ3GEYF183	18K	
R11	ERJ3GEYF103	10K	
R12	ERJ3GEYJ393	39K	
R15	ERJ3GEYJ100	10	
R20	ERJ2GEJ102	1K	
R21	ERJ2GEJ102	1K	
R24	ERJ3GEYJ474	470K	
R25	ERJ3GEYJ331	330	
R26	ERJ3GEYJ101	100	
R29	ERJ3GEYJ222	2.2K	
R35	ERJ3GEYJ273	27K	
R36	ERJ3GEYJ473	47K	
R37	ERJ3GEYJ330	33	
R38	ERJ3GEYJ330	33	
R39	ERJ3GEYJ104	100K	
R40	ERJ3GEYJ103	10K	
R43	ERJ6RSJR10V	0.1	
R46	ERJ3GEYJ562	5.6K	
R47	ERJ3GEYJ562	5.6K	
R57	ERJ3GEYJ680	68	
R59	ERJ3GEYJ221	220	
R60	ERJ3GEYJ102	1K	
R61	ERJ3GEYJ103	10K	
R63	ERJ3GEYJ103	10K	
R64	ERJ3GEYJ103	10K	
R72	ERJ3GEYJ102	1K	
R73	ERJ3GEYJ474	470K	
R74	ERJ3GEYJ1R0	1	
R75	ERJ2GEJ102	1K	
R80	ERJ3GEYJ100	10	
R81	ERJ3GEYJ390	39	
R82	ERJ2GEJ100	10	
R95	ERJ3GEYJ103	10K	
R117	ERJ3GEYJ102	1K	
R121	ERJ2GE0R00	0	
R123	ERJ2GE0R00	0	
R125	ERJ2GE0R00	0	
R127	ERJ2GE0R00	0	
R129	ERJ2GE0R00	0	
R131	ERJ2GE0R00	0	
R134	ERJ3GEYJ470	47	
R135	ERJ3GEYJ470	47	
R136	ERJ3GEYF114V	110K	
R137	ERJ2GEJ103	10K	
L8	ERJ6GEY0R00	0	S
		(CAPACITORS)	
C1	EEE0GA331WP	330	
C3	ECUV1C104KBV	0.1	
C4	ECUV1H100DCV	10P	
C5	ECST0JY106	10	
C7	ECUV1H100DCV	10P	
C8	ECUV1A224KBV	0.22	
C9	ECUV1C683KBV	0.068	
C10	ECUV1C104KBV	0.1	
C12	ECUV1A105KBV	1	
C13	ECUV1C104KBV	0.1	
C14	ECUV1H100DCV	10P	
C15	ECUV1A105KBV	1	
C16	ECUV1C104KBV	0.1	
C17	ECUV1H330JCV	33P	
C18	ECUV1H102KBV	0.001	
C19	ECUV1C104KBV	0.1	
C20	F1G1A1040003	0.1	
C21	ECUV1C104KBV	0.1	
C22	ECUV1C104KBV	0.1	
C23	ECUV1C104KBV	0.1	
C24	F1G1A1040003	0.1	
C26	ECUV1C104KBV	0.1	

Ref. No.	Part No.	Part Name & Description	Remarks
C30	ECUV1A105KBV	1	
C37	ECUV1C683KBV	0.068	
C38	ECUV1H471JCV	470P	S
C39	ECUV1A105KBV	1	
C40	ECST0JY106	10	
C44	ECJ0EC1H100D	10P	
C45	ECJ0EB1H102K	0.001	
C46	ECJ0EC1H100D	10P	
C47	ECJ0EC1H020C	2P	
C48	ECJ0EC1H100D	10P	
C49	ECJ0EC1H020C	2P	
C50	ECJ0EC1H100D	10P	
C51	ECJ0EC1H100D	10P	
C53	ECJ0EC1H151J	150P	
C54	ECJ0EC1H100D	10P	
C55	ECJ0EC1H020C	2P	
C56	ECJ0EC1H100D	10P	
C57	EEE0JA331P	330	
C58	F1G1A1040003	0.1	
C59	ECUV1A105KBV	1	
C68	ECUV1C683KBV	0.068	
C73	ECUV1C104KBV	0.1	
C74	ECUV1C104KBV	0.1	
C75	ECUV1H100DCV	10P	
C77	ECUV1H100DCV	10P	
C80	PQCUV1A225KB	2.2	
C83	ECJ0EB1H102K	0.001	
C86	ECUV1A105KBV	1	
C87	ECUV1H100DCV	10P	
C89	ECUV1H100DCV	10P	
C90	ECUV1H100DCV	10P	
C91	ECUV1H100DCV	10P	
C92	ECUV1H100DCV	10P	
C93	ECUV1H101JCV	100P	
C94	ECUV1H101JCV	100P	
C102	ECUV1A105KBV	1	
C109	ECUV1C104KBV	0.1	
C115	ECUV1A475KB	4.7	
C117	ECJ0EC1H220J	22P	
C119	ECUV1A475KB	4.7	
C125	ECUV1H020CCV	2P	
		(OTHERS)	
MIC	L0CBAB000052	MICROPHONE	
E101	L5DZDD00004	LCD ASSEMBLY (*2)	
E102	PQHX11300Z	PLASTIC PARTS, SHEET	
E103	PQSA10159Z	ANTENNA	
CN6	PQLP10263Z	RF UNIT	
X1	H0D103500006	CRYSTAL OSCILLATOR	
CN5	X1MN20B00108	CONNECTOR	

31.3. Charger Unit

31.3.1. Cabinet and Electrical Parts

Ref. No.	Part No.	Part Name & Description	Remarks
200	PQLV30032ZS	CHARGER UNIT (for KX-TCA130UAS)	
200	PQLV30032ZT	CHARGER UNIT (for KX-TCA130UAT)	
200-1	PQGG10276Z1	GRILLE (for KX-TCA130UAS)	PC-HB
200-1	PQGG10276Z3	GRILLE (for KX-TCA130UAT)	PC-HB
200-2	PQKM10656Z1	CABINET BODY (for KX-TCA130UAS)	ABS-HB
200-2	PQKM10656Z3	CABINET BODY (for KX-TCA130UAT)	ABS-HB
200-3	PQHR11085Z	CASE, CHARGE TERMINAL	
200-4	PQKE10384Z1	HOLDER, CHARGE TERMINAL (R)	POM-HB
200-5	PQKE10385Z1	HOLDER, CHARGE TERMINAL (L)	POM-HB
200-6	PQJT10218Y	CHARGE TERMINAL (R)	
200-7	PQJT10219Y	CHARGE TERMINAL (L)	
200-8	PQKF10653Z1	CABINET COVER (for KX-TCA130UAS)	PS-HB

Ref. No.	Part No.	Part Name & Description	Remarks
200-8	PQKF10653Z3	CABINET COVER (for KX-TCA130UAT)	PS-HB
200-9	PQGT17399Z	NAME PLATE (for KX-TCA130UAS)	
200-9	PQGT17399X	NAME PLATE (for KX-TCA130UAT)	
200-10	PQHA10023Z	RUBBER PARTS, FOOT CUSHION	

31.3.2. Main P.C.Board Parts

Ref. No.	Part No.	Part Name & Description	Remarks
PCB200	PQWPA130ETCH	MAIN P.C.BOARD ASS'Y (RTL)	
		(DIODE)	
D11	B0JCME000035	DIODE (SI)	
		(JACK)	
J1	PQJJ1B4Y	JACK	S
		(RESISTORS)	
R11	ERJ1WYJ220	22	
R12	ERJ1WYJ220	22	

31.4. Accessories and Packing Materials

Note:

(*1) You can download and refer to the Operating Instructions (Instruction book) on TSN Server.

31.4.1. KX-TC346UAS/UAT

Ref. No.	Part No.	Part Name & Description	Remarks
A1	PQLV19CEX	AC ADAPTOR	△
A2	PQJA10075Z	CORD, TELEPHONE	
A3	PQX14702Z	INSTRUCTION BOOK (for Russian) (*1)	
A4	PQX14703Z	INSTRUCTION BOOK (for Ukrainian) (*1)	
A5	PQW14766Z	QUICK GUIDE (for Russian)	
A6	PQW14767Z	QUICK GUIDE (for Ukrainian)	
A7	PQW14964Z	LEAFLET	
A8	PQW14854Z	LEAFLET	
P1	PQPP10124Z	PROTECTION COVER (for Base Unit)	
P2	PQPP10084Z	PROTECTION COVER (for Handset)	
P3	PQPK14874Z	GIFT BOX	

31.4.2. KX-TCA130UAS/UAT

Ref. No.	Part No.	Part Name & Description	Remarks
A1	PQLV200CEX	AC ADAPTOR	△
A2	PQX14475Z	INSTRUCTION BOOK (for Russian) (*1)	
A3	PQX14476Z	INSTRUCTION BOOK (for Ukrainian) (*1)	
P1	PQPP10086Z	PROTECTION COVER (for Charger Unit)	
P2	PQPP10084Z	PROTECTION COVER (for Handset)	
P3	PQPK14608Z	GIFT BOX	

31.5. Fixtures and Tools

Note:

(*1) See The Setting Method of JIG (Base Unit) (P.32), and The Setting Method of JIG (Handset) (P.39).

Part No.	Part Name & Description	Remarks
PQZZ1CD300E	JIG CABLE (*1)	
PQZZTCD346UA	BATCH FILE (*1)	

Memo

32 FOR SCHEMATIC DIAGRAM

32.1. Base Unit (SCHEMATIC DIAGRAM (BASE UNIT_MAIN))

Notes:

1. DC voltage measurements are taken with voltmeter from the negative voltage line.

Important Safety Notice:
Components identified by ⚠ mark have special characteristics important for safety. When replacing any of these components, use only the manufacturer's specified parts.

2. This schematic diagram may be modified at any time with the development of new technology.

32.2. Handset (SCHEMATIC DIAGRAM (HANDSET))

Notes:

1. DC voltage measurements are taken with an oscilloscope or a tester with a ground.
2. The schematic diagrams and circuit board may be modified at any time with the development of new technology.

32.3. Charger Unit (SCHEMATIC DIAGRAM (CHARGER UNIT))

Notes:

1. DC voltage measurements are taken with voltmeter from the negative voltage line.

Important Safety Notice:
Components identified by ⚠ mark have special characteristics important for safety. When replacing any of these components, use only the manufacturer's specified parts.

2. This schematic diagram may be modified at any time with the development of new technology.

33 SCHEMATIC DIAGRAM (BASE UNIT_MAIN)

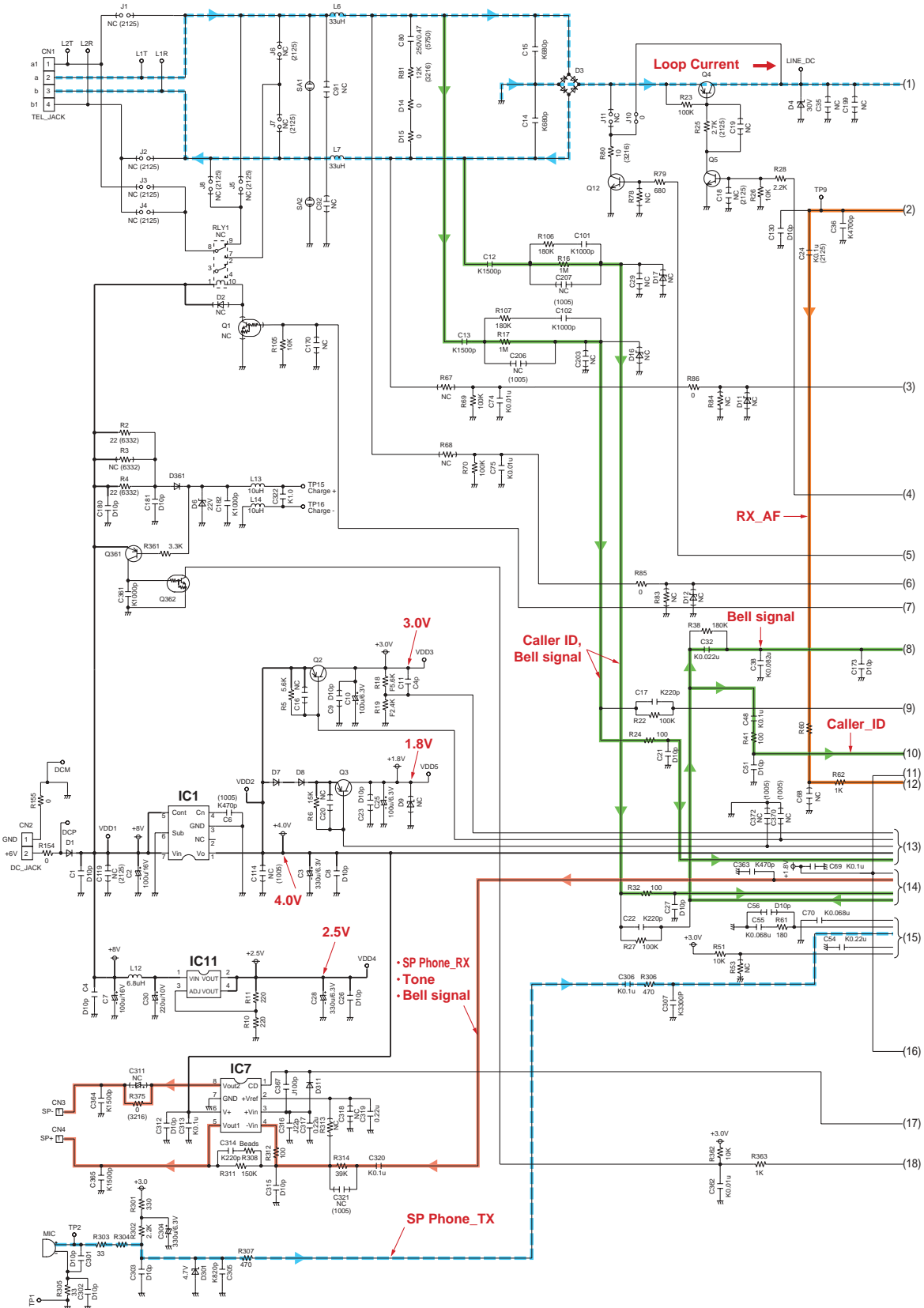

NC : No Components

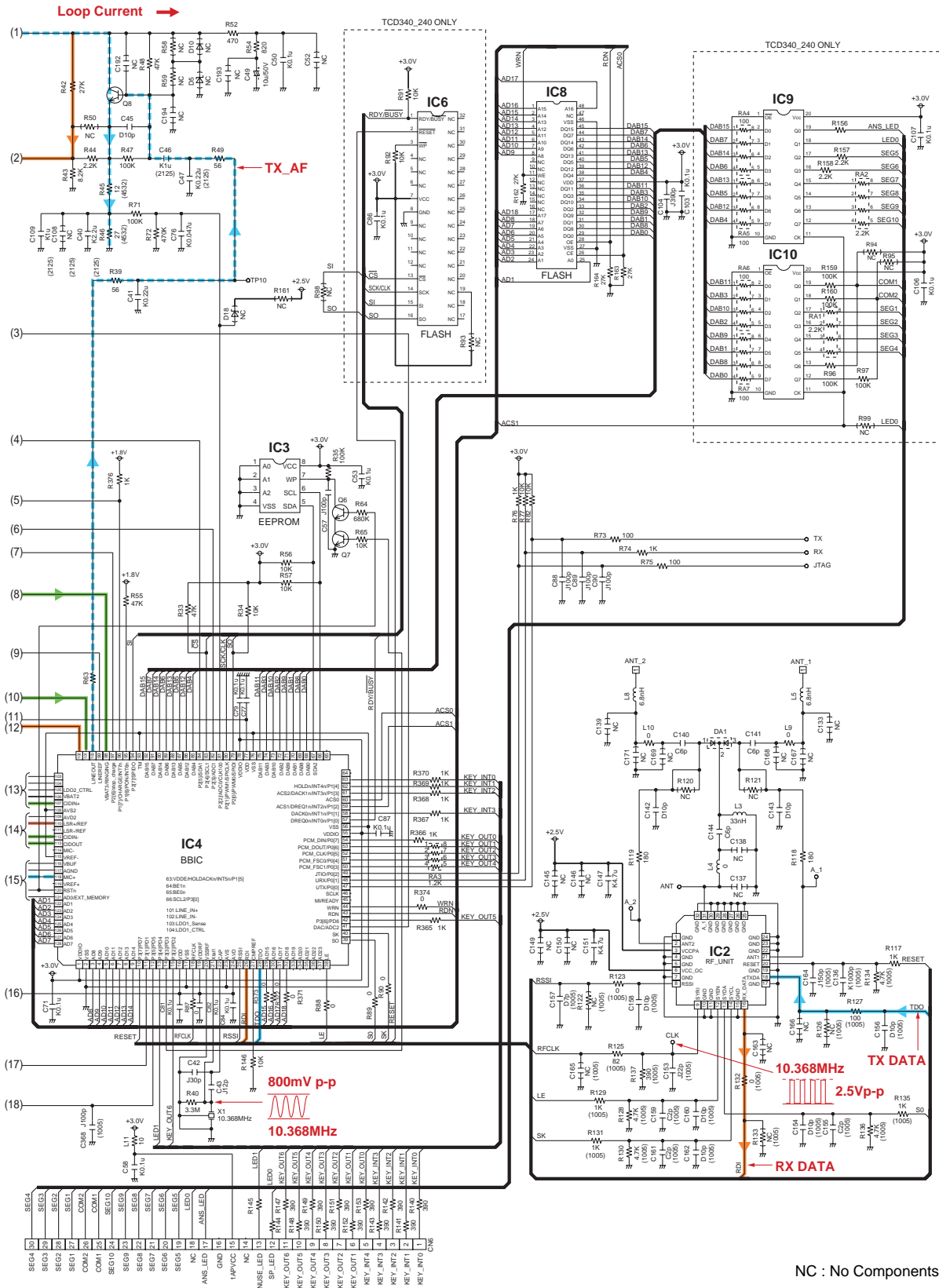

KX-TCD346 SCHEMATIC DIAGRAM (BASE UNIT)

34 SCHEMATIC DIAGRAM (BASE UNIT_OPERATION)

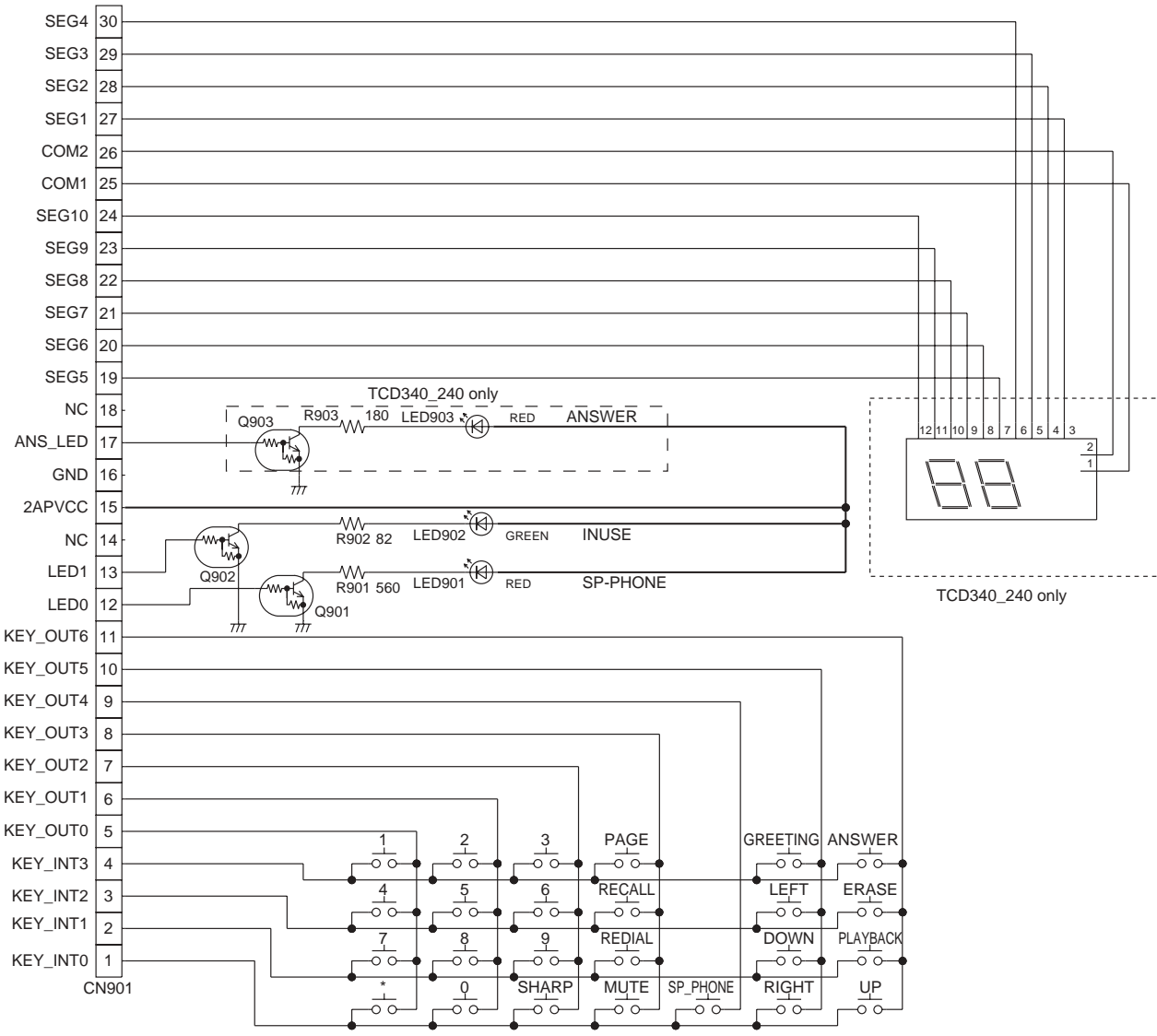

KX-TCD346 SCHEMATIC DIAGRAM (Base Unit_Operation)

Memo

35 SCHEMATIC DIAGRAM (HANDSET)

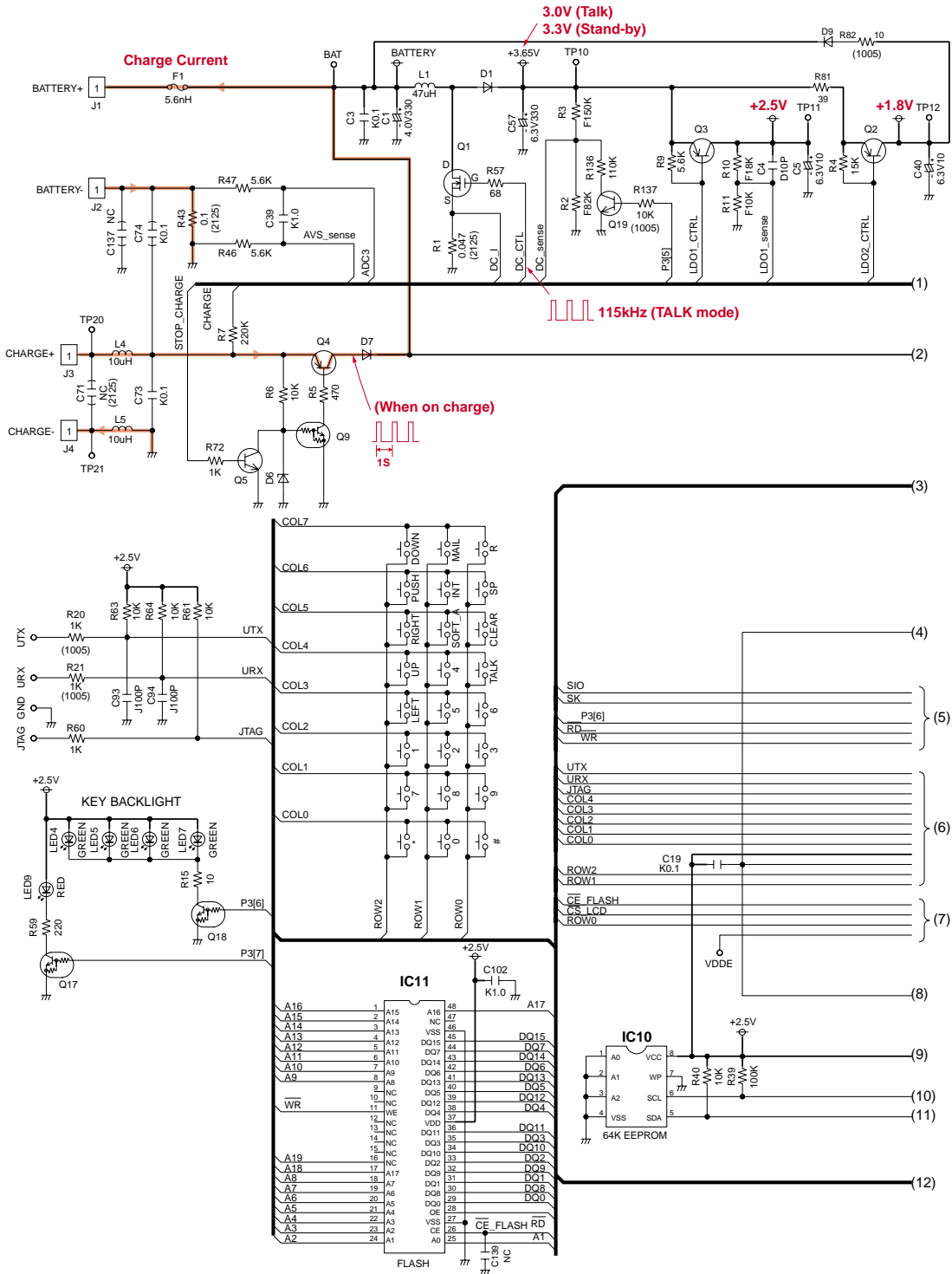

NC : No Components

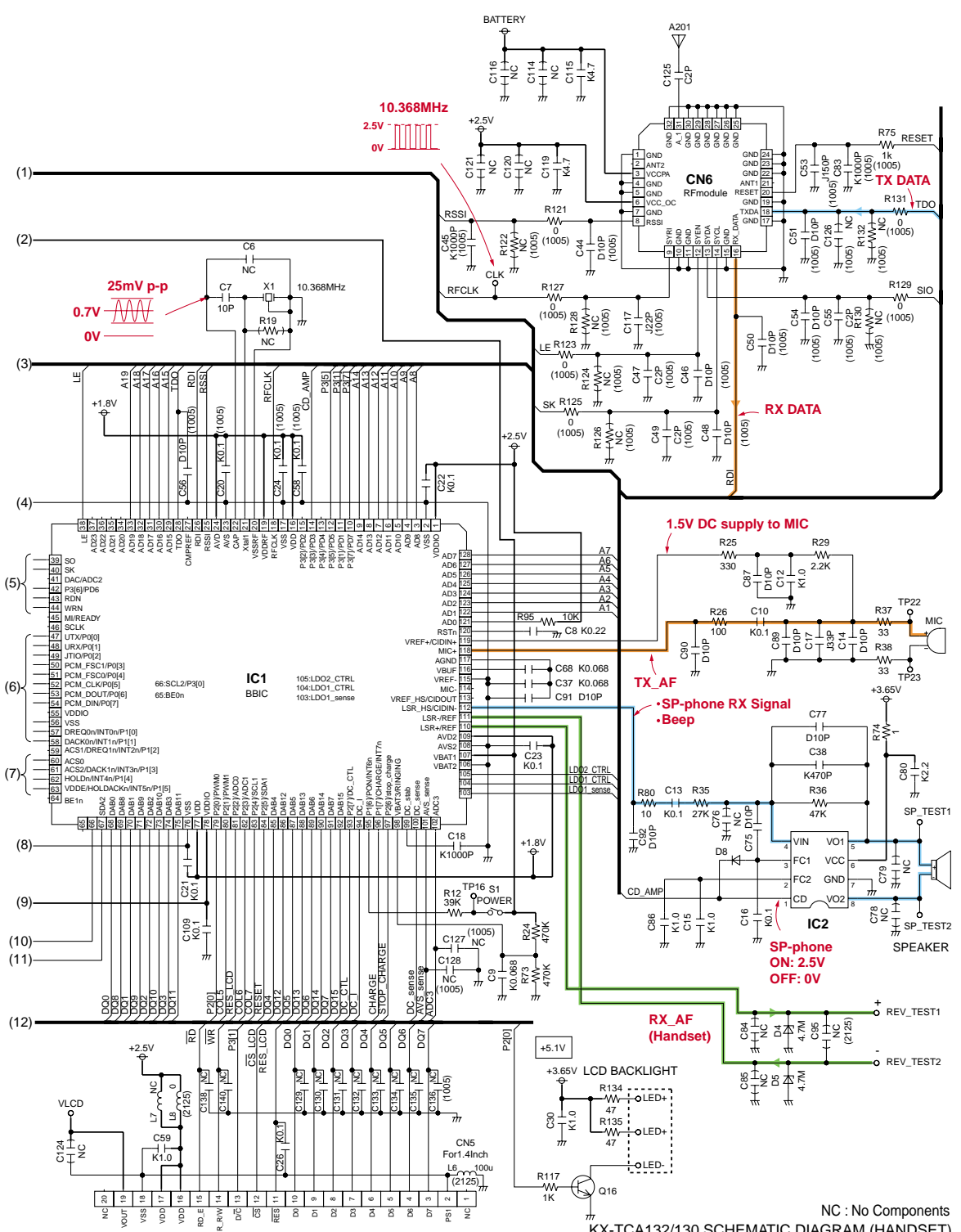

NC : No Components

KX-TCA132/130 SCHEMATIC DIAGRAM (HANDSET)

36 SCHEMATIC DIAGRAM (CHARGER UNIT)

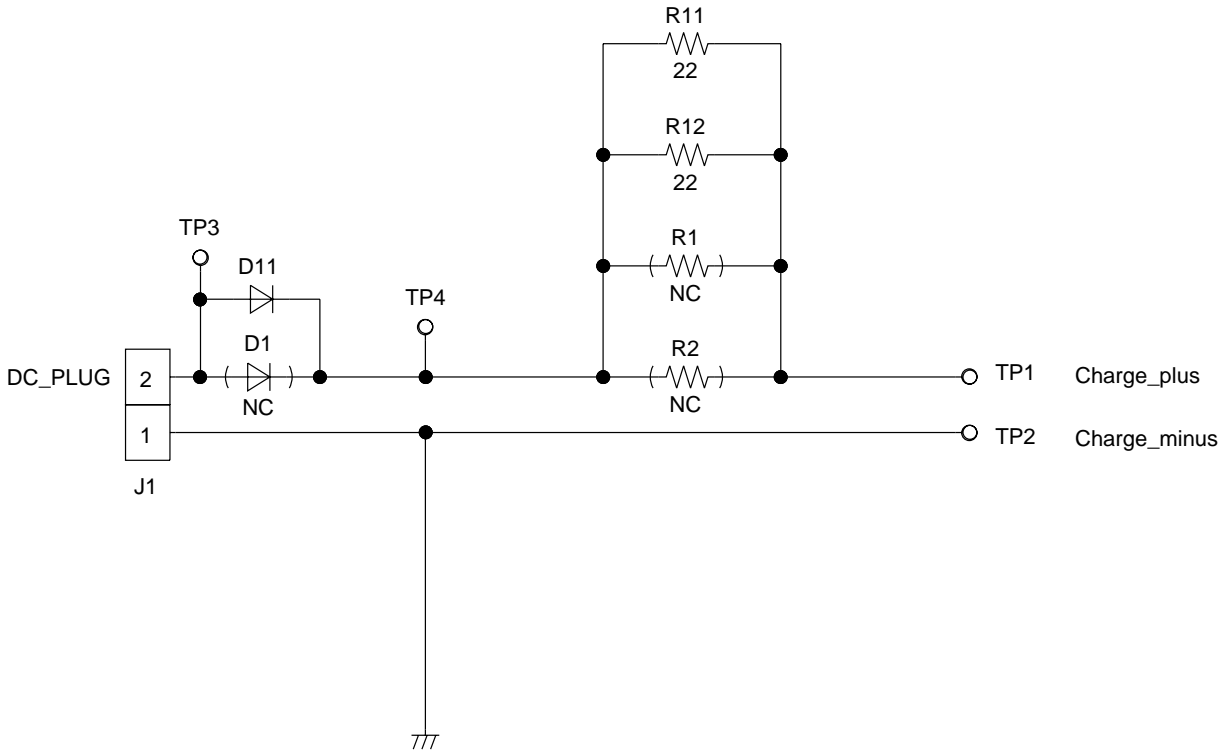

NC : No Components

SCHEMATIC DIAGRAM (CHARGER UNIT)

37 CIRCUIT BOARD (BASE UNIT_MAIN)

37.1. Component View

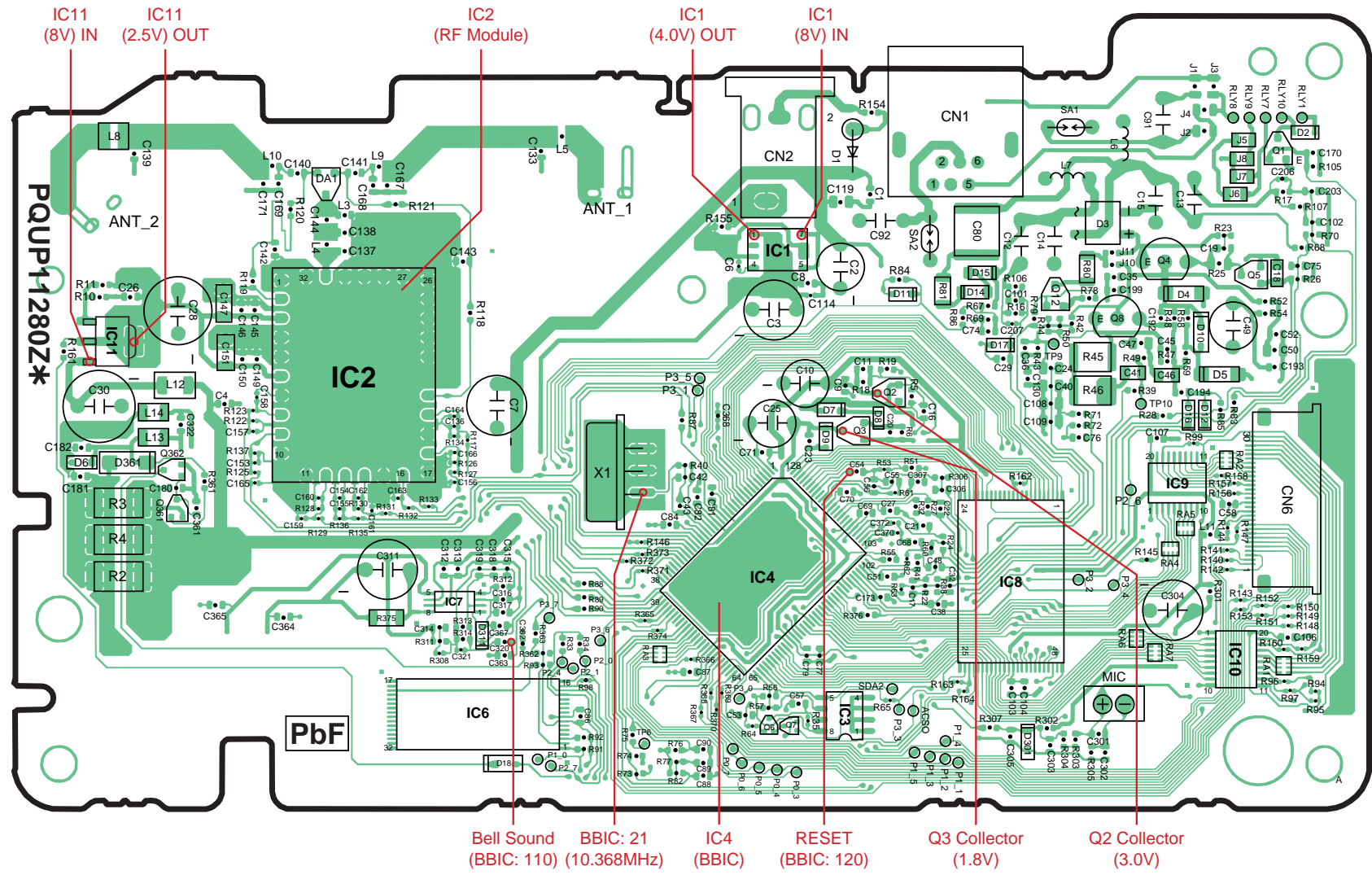

KX-TCD346 CIRCUIT BOARD (Base Unit_Main (Component View))

37.2. Flow Solder Side View

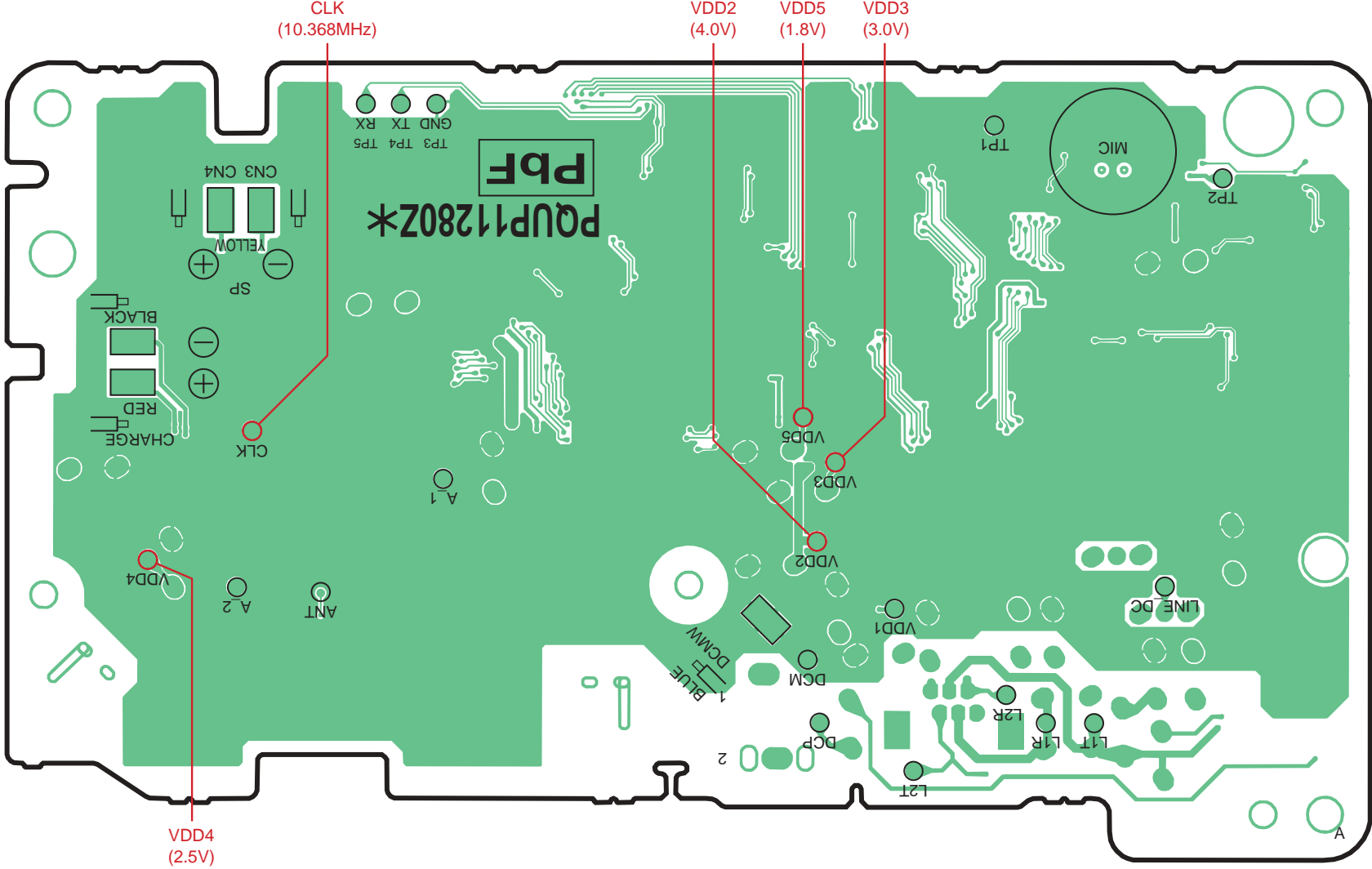

KX-TC346 CIRCUIT BOARD (Base Unit_Main (Flow Solder Side View))

38 CIRCUIT BOARD (BASE UNIT_OPERATION)

38.1. Component View

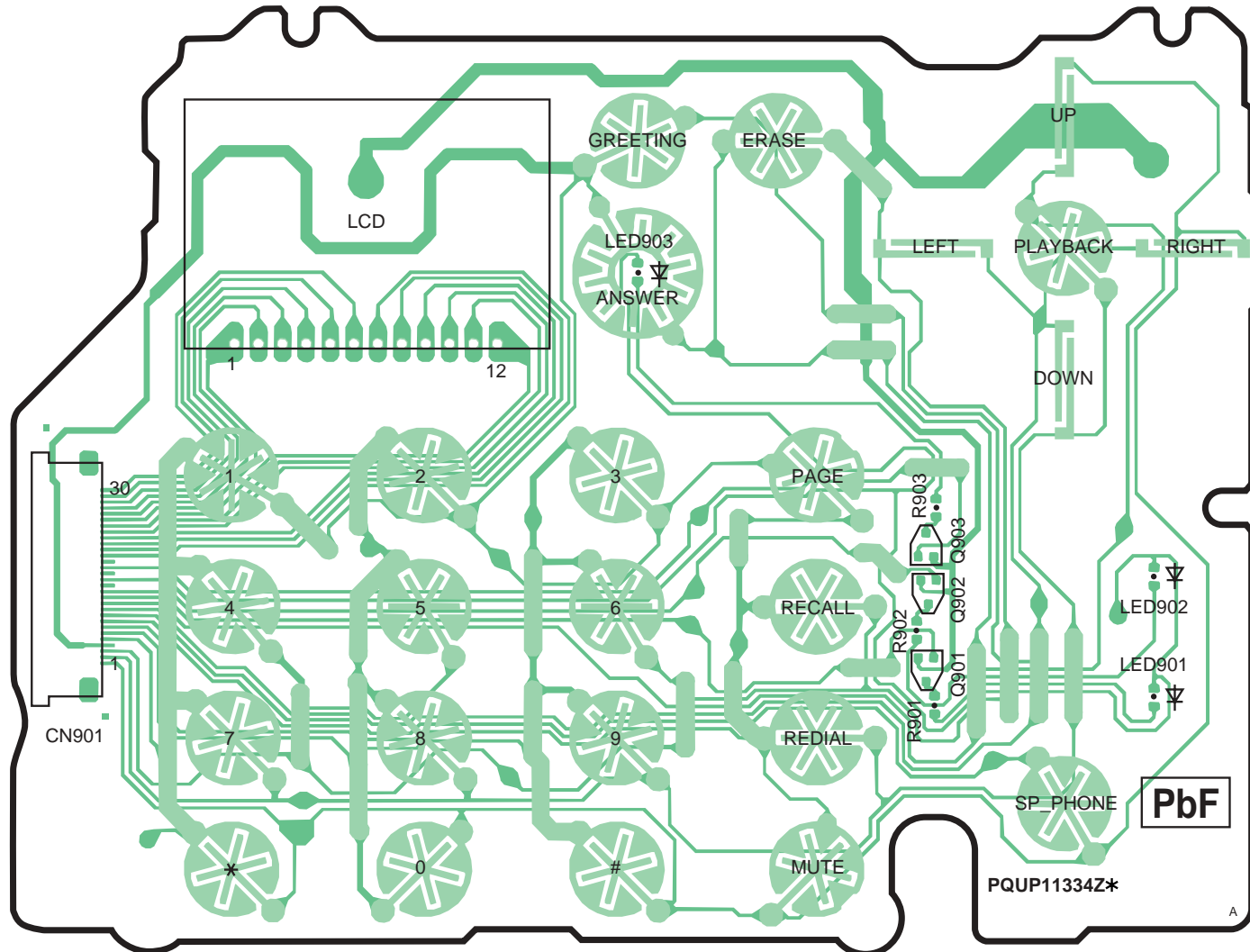

KX-TCD346 CIRCUIT BOARD (Base Unit_Operation (Component View))

38.2. Flow Solder Side View

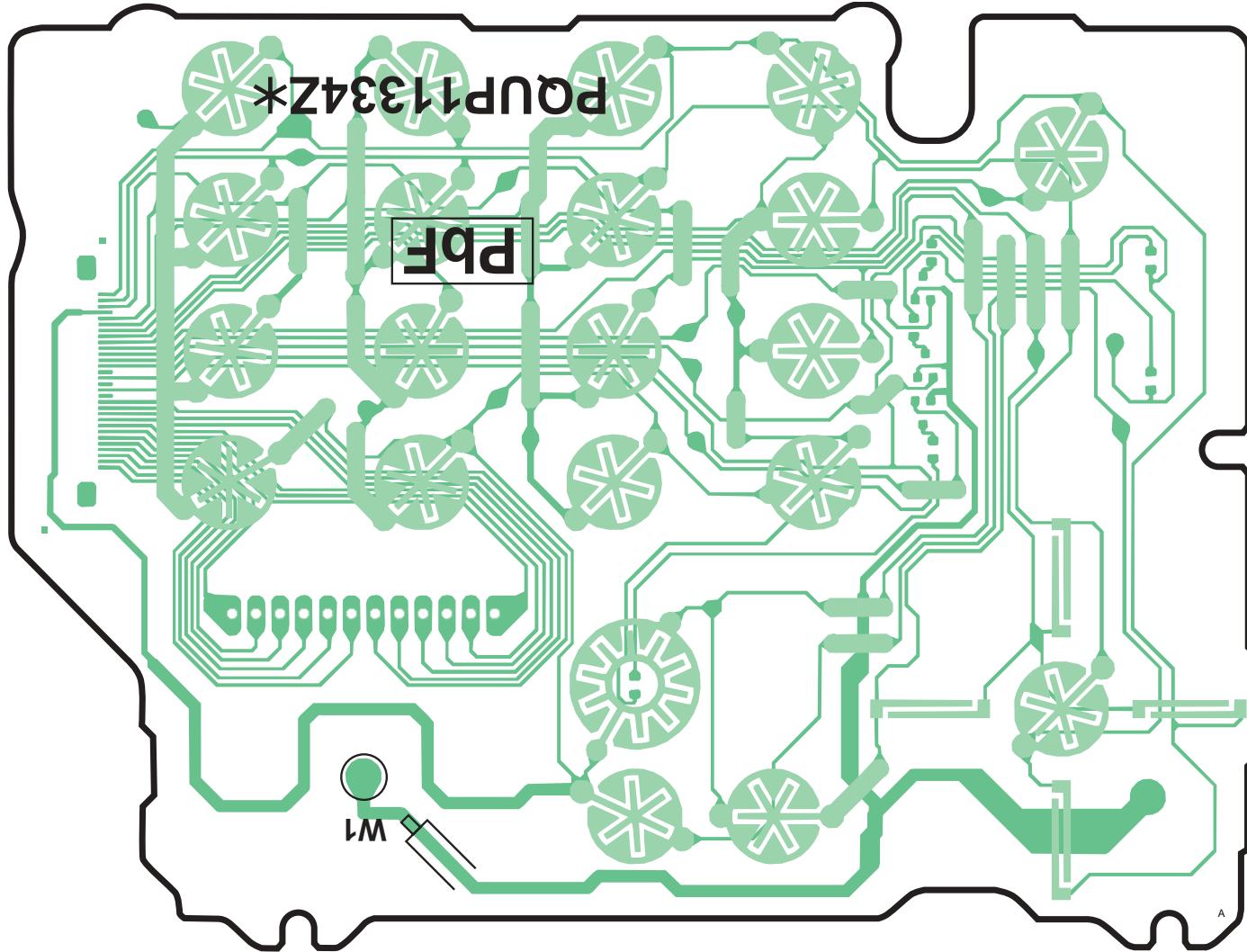

KX-TC346 CIRCUIT BOARD (Base Unit_Operation (Flow Solder Side View))

39 CIRCUIT BOARD (HANDSET)

39.1. Component View

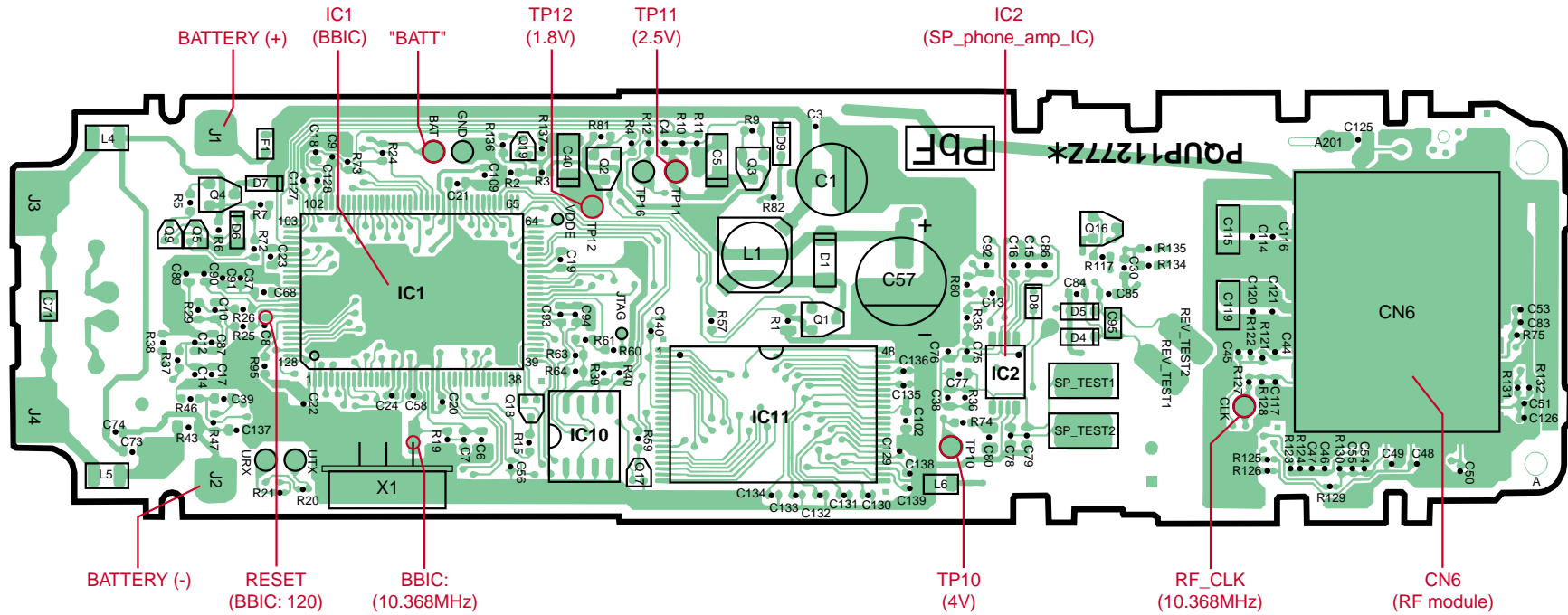

KX-TCA132/130 CIRCUIT BOARD (HANDSET) Component View

39.2. Flow Solder Side View

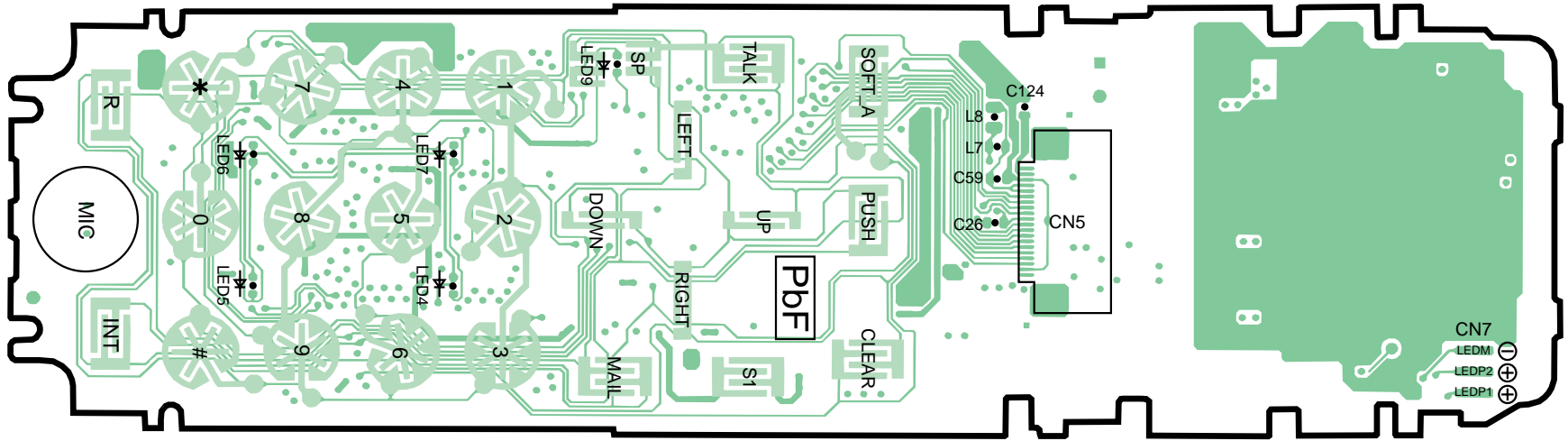

KX-TCA132/130 CIRCUIT BOARD (HANDSET) Flow Solder Side View

40 CIRCUIT BOARD (CHARGER UNIT)

40.1. Component View

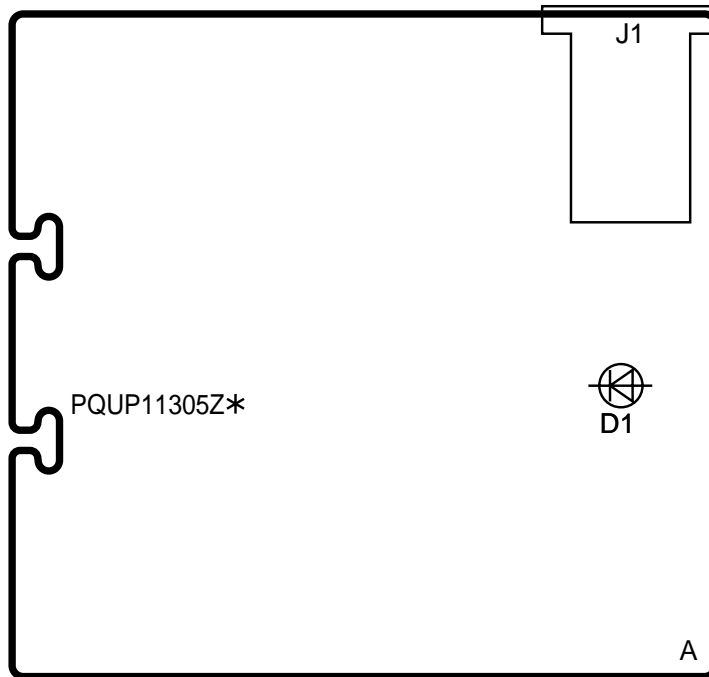

CIRCUIT BOARD (CHARGER UNIT) Component View

40.2. Flow Solder Side View

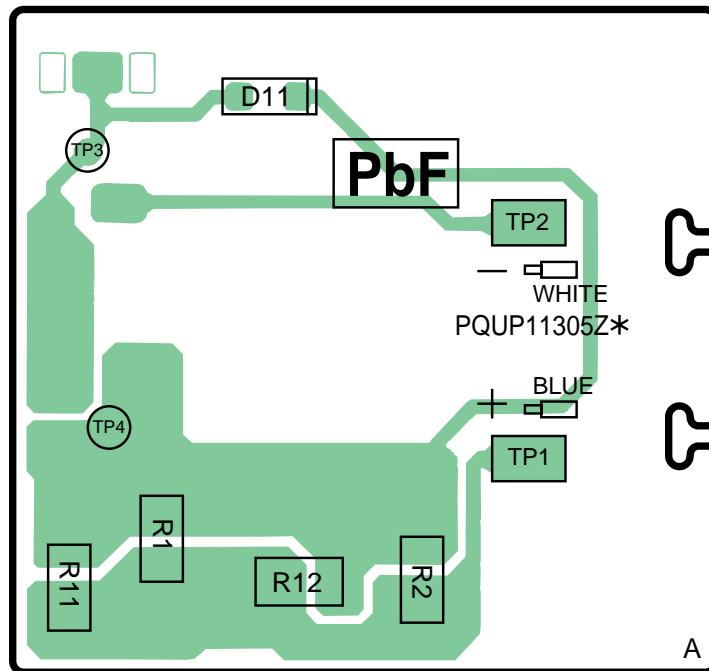

CIRCUIT BOARD (CHARGER UNIT) Flow Solder Side View

I.N/S
 KXTCD346UAS
 KXTCD346UAT
 KXTCA132UAS
 KXTCA132UAT
 KXTCA130UAS
 KXTCA130UAT