

# Panasonic<sup>®</sup>

## Operating Instructions

---

Digital Cordless Phone

Model No. **KX-TG2711HK**  
**KX-TG2712HK**



Model shown is KX-TG2711.

***Before initial use, see “Getting Started”  
on page 8.***

**Thank you for purchasing a Panasonic product.**

Please read these operating instructions before using the unit and save them for future reference.

## Table of Contents

---

### Introduction

Model composition .....	3
Accessory information .....	3

### Important Information

For your safety .....	5
Important safety instructions .....	6
For best performance .....	6
Other information .....	7
Specifications .....	7

### Getting Started

Setting up .....	8
Note when setting up .....	9
Controls .....	10
Display .....	10
Turning the power on/off .....	11
Initial settings .....	11
One touch eco mode .....	12

### Making/Answering Calls

Making calls .....	13
Answering calls .....	13
Useful features during a call .....	14

### Phonebook

Handset phonebook .....	15
Copying phonebook entries .....	15

### Programming

Programmable settings .....	17
Special programming .....	18

### Caller ID Service

Using Caller ID service .....	20
Caller list .....	20

### Voice Mail Service

Voice mail service .....	22
--------------------------	----

### Intercom/Locator

Intercom .....	23
Handset locator .....	23
Transferring calls, conference calls .....	23

### Useful Information

Character entry .....	24
Error messages .....	26
Troubleshooting .....	26

Wall mounting .....	30
---------------------	----

### Index

Index .....	31
-------------	----

## Model composition

Series	Model No.	Base unit	Handset	
		Part No.	Part No.	Quantity
KX-TG2711 series	KX-TG2711	KX-TG2711	KX-TGA277	1
	KX-TG2712	KX-TG2711	KX-TGA277	2

- Intercom calls and the phonebook copy feature are only available for KX-TG2712.
- The suffix (HK) in the following model numbers will be omitted in these instructions:  
KX-TG2711HK/KX-TG2712HK

## Accessory information

### Supplied accessories

No.	Accessory item/Part number	Quantity	
		KX-TG2711	KX-TG2712
①	AC adaptor/PNLV226E	1	2
②	Telephone line cord	2	2
③	Rechargeable batteries*1	2	4
④	Handset cover*2	1	2
⑤	Charger	–	1

\*1 See page 4 for replacement battery information.

\*2 The handset cover comes attached to the handset.

①



②



③



④



⑤



## ***Introduction***

---

### **Additional/replacement accessories**

Please contact your nearest Panasonic dealer for sales information.  
For enquiry, please call hotline 2313 0666.

<b>Accessory item</b>	<b>Model number</b>
Rechargeable batteries	HHR-4MVT or HHR-4MRT*1
	Battery type: <ul style="list-style-type: none"><li>– Nickel metal hydride (Ni-MH)</li><li>– 2 x AAA (R03) size for each handset</li></ul>
DECT repeater	KX-A405

\*1 Replacement batteries may have a different capacity from that of the supplied batteries.

### For your safety

To prevent severe injury and loss of life/property, read this section carefully before using the product to ensure proper and safe operation of your product.

### WARNING

#### Power connection

- Use only the power source marked on the product.
- Do not overload power outlets and extension cords. This can result in the risk of fire or electric shock.
- Completely insert the AC adaptor/power plug into the power outlet. Failure to do so may cause electric shock and/or excessive heat resulting in a fire.
- Regularly remove any dust, etc. from the AC adaptor/power plug by pulling it from the power outlet, then wiping with a dry cloth. Accumulated dust may cause an insulation defect from moisture, etc. resulting in a fire.
- Unplug the product from power outlets if it emits smoke, an abnormal smell, or makes an unusual noise. These conditions can cause fire or electric shock. Confirm that smoke has stopped emitting and contact an authorised service centre.
- Unplug from power outlets and never touch the inside of the product if its casing has been broken open.
- Never touch the plug with wet hands. Danger of electric shock exists.

#### Installation

- To prevent the risk of fire or electrical shock, do not expose the product to rain or any type of moisture.
- Do not place or use this product near automatically controlled devices such as automatic doors and fire alarms. Radio waves emitted from this product may cause such devices to malfunction resulting in an accident.

- Do not allow the AC adaptor or telephone line cord to be excessively pulled, bent or placed under heavy objects.

#### Operating safeguards

- Unplug the product from power outlets before cleaning. Do not use liquid or aerosol cleaners.
- Do not disassemble the product.
- Do not spill liquids (detergents, cleansers, etc.) onto the telephone line cord plug, or allow it to become wet at all. This may cause a fire. If the telephone line cord plug becomes wet, immediately pull it from the telephone wall jack, and do not use.

#### Medical

- Consult the manufacturer of any personal medical devices, such as pacemakers or hearing aids, to determine if they are adequately shielded from external RF (radio frequency) energy. (The product operates in the frequency range of 1.88 GHz to 1.90 GHz, and the RF transmission power is 250 mW (max.).)
- Do not use the product in health care facilities if any regulations posted in the area instruct you not to do so. Hospitals or health care facilities may be using equipment that could be sensitive to external RF energy.

### CAUTION

#### Installation and location

- Never install telephone wiring during an electrical storm.
- Never install telephone line jacks in wet locations unless the jack is specifically designed for wet locations.
- Never touch uninsulated telephone wires or terminals unless the telephone line has been disconnected at the network interface.
- Use caution when installing or modifying telephone lines.
- The AC adaptor is used as the main disconnect device. Ensure that the AC outlet is installed near the product and is easily accessible.
- This product is unable to make calls when:

## Important Information

- the handset batteries need recharging or have failed.
- there is a power failure.

### Battery

- We recommend using the batteries noted on page 4. **USE ONLY rechargeable Ni-MH batteries AAA (R03) size.**
- Do not mix old and new batteries.
- Do not open or mutilate the batteries. Released electrolyte from the batteries is corrosive and may cause burns or injury to the eyes or skin. The electrolyte is toxic and may be harmful if swallowed.
- Exercise care when handling the batteries. Do not allow conductive materials such as rings, bracelets, or keys to touch the batteries, otherwise a short circuit may cause the batteries and/or the conductive material to overheat and cause burns.
- Charge the batteries provided with or identified for use with this product only, in accordance with the instructions and limitations specified in this manual.
- Only use a compatible base unit (or charger) to charge the batteries. Do not tamper with the base unit (or charger). Failure to follow these instructions may cause the batteries to swell or explode.

## Important safety instructions

When using your product, basic safety precautions should always be followed to reduce the risk of fire, electric shock, and injury to persons, including the following:

1. Do not use this product near water for example, near a bathtub, washbowl, kitchen sink, or laundry tub, in a wet basement or near a swimming pool.
2. Avoid using a telephone (other than a cordless type) during an electrical storm. There may be a remote risk of electric shock from lightning.
3. Do not use the telephone to report a gas leak in the vicinity of the leak.
4. Use only the power cord and batteries indicated in this manual. Do not dispose of

batteries in a fire. They may explode. Check with local codes for possible special disposal instructions.

### SAVE THESE INSTRUCTIONS

## For best performance

### Base unit location/avoiding noise

The base unit and other compatible Panasonic units use radio waves to communicate with each other.

- For maximum coverage and noise-free communications, place your base unit:
  - at a convenient, high, and central location with no obstructions between the handset and base unit in an indoor environment.
  - away from electronic appliances such as TVs, radios, personal computers, wireless devices, or other phones.
  - facing away from radio frequency transmitters, such as external antennas of mobile phone cell stations. (Avoid putting the base unit on a bay window or near a window.)
- Coverage and voice quality depends on the local environmental conditions.
- If the reception for a base unit location is not satisfactory, move the base unit to another location for better reception.

### Environment

- Keep the product away from electrical noise generating devices, such as fluorescent lamps and motors.
- The product should be kept free from excessive smoke, dust, high temperature, and vibration.
- The product should not be exposed to direct sunlight.
- Do not place heavy objects on top of the product.
- When you leave the product unused for a long period of time, unplug the product from the power outlet.
- The product should be kept away from heat sources such as radiators, cookers, etc. It should not be placed in rooms where the temperature is less than 0 °C or greater

than 40 °C. Damp basements should also be avoided.

- The maximum calling distance may be shortened when the product is used in the following places: Near obstacles such as hills, tunnels, underground, near metal objects such as wire fences, etc.
- Operating the product near electrical appliances may cause interference. Move away from the electrical appliances.

### Routine care

- Wipe the outer surface of the product with a soft moist cloth.
- Do not use benzine, thinner, or any abrasive powder.

### Other information

**CAUTION:** Risk of explosion if battery is replaced by an incorrect type. Dispose of used batteries according to the instructions.

### Notice for product disposal, transfer, or return

- This product can store your private/confidential information. To protect your privacy/confidentiality, we recommend that you erase information such as phonebook or caller list entries from the memory before you dispose of, transfer, or return the product.

### Information on Disposal in other Countries outside the European Union



These symbols are only valid in the European Union. If you wish to discard these items, please contact your local authorities or dealer and ask for the correct method of disposal.

### Specifications

- **Standard:**  
DECT (Digital Enhanced Cordless Telecommunications),  
GAP (Generic Access Profile)
- **Number of channels:**  
120 Duplex Channels
- **Frequency range:**  
1.88 GHz to 1.90 GHz
- **RF transmission power:**  
Approx. 10 mW (average power per channel)
- **Power source:**  
220–240 V AC, 50/60 Hz
- **Power consumption:**  
**Base unit:**  
Standby: Approx. 0.52 W  
Maximum: Approx. 2.7 W  
**Charger:**  
Standby: Approx. 0.1 W  
Maximum: Approx. 1.8 W
- **Operating conditions:**  
0 °C – 40 °C, 20 % – 80 % relative air humidity (dry)
- **Dimensions:**
  - **Base unit:** Approx. 52 mm × 97 mm × 117 mm
  - **Handset:** Approx. 154 mm × 48 mm × 29 mm
  - **Charger:** Approx. 43 mm × 72 mm × 81 mm
- **Mass (weight):**
  - **Base unit:** Approx. 114 g
  - **Handset:** Approx. 127 g
  - **Charger:** Approx. 54 g

#### Note:

- Design and specifications are subject to change without notice.
- The illustrations in these instructions may vary slightly from the actual product.

## Setting up

### Connections

- Use only the supplied Panasonic AC adaptor PNLV226E.
- When mounting the unit on a wall, see page 30.

#### ■ Base unit

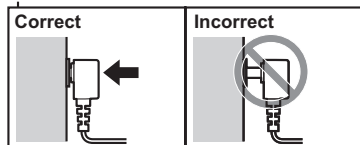
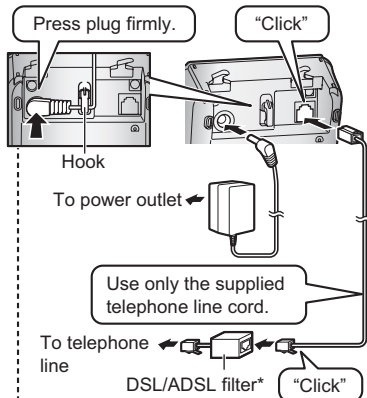

\*DSL/ADSL filter (not supplied) is required if you have DSL/ADSL service.

#### ■ Charger

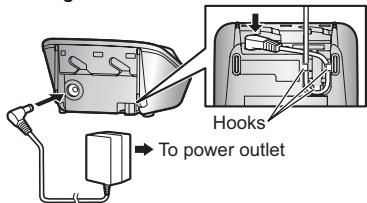

## Battery installation

- USE ONLY Ni-MH batteries AAA (R03) size.
- Do NOT use Alkaline/Manganese/Ni-Cd batteries.
- Confirm correct polarities ( $\oplus$ ,  $\ominus$ ).

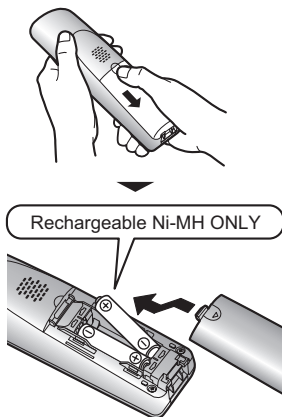

## Battery charging

Charge for about 7 hours.

- When the batteries are fully charged, "Fully charged" is displayed.

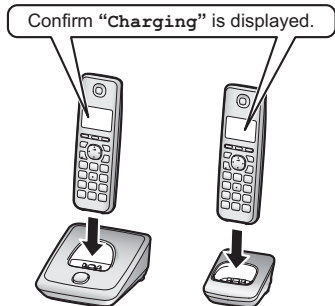



## Note when setting up

### Note for connections

- The AC adaptor must remain connected at all times. (It is normal for the adaptor to feel warm during use.)
- The AC adaptor should be connected to a vertically oriented or floor-mounted AC outlet. Do not connect the AC adaptor to a ceiling-mounted AC outlet, as the weight of the adaptor may cause it to become disconnected.
- If the unit is connected to a PBX system, please contact your PBX supplier.

### During a power failure

The unit will not work during a power failure. We recommend connecting a corded-type telephone (without AC adaptor) to the same telephone line or to the same telephone line jack using a T-adaptor.

### Note for battery installation

- Use the supplied rechargeable batteries. For replacement, we recommend using the Panasonic rechargeable batteries noted on page 4, 6.
- Wipe the battery ends (+, -) with a dry cloth.
- Avoid touching the battery ends (+, -) or the unit contacts.

### Note for battery charging

- It is normal for the handset to feel warm during charging.
- Clean the charge contacts of the handset, base unit, and charger with a soft and dry cloth once a month. Before cleaning the unit, disconnect from power outlets and any telephone line cords. Clean more often if the unit is exposed to grease, dust, or high humidity.

### Battery level

Icon	Battery level
	High
	Medium
	Low
	Needs charging.

### Panasonic Ni-MH battery performance (supplied batteries)

Operation	Operating time
In continuous use	20 hours max.
Not in use (standby)	170 hours max.

#### Note:

- It is normal for batteries not to reach full capacity at the initial charge. Maximum battery performance is reached after a few complete cycles of charge/discharge (use).
- To maximise battery life, it is recommended that the handset batteries be fully discharged (used) until flashes once every few months.
- Actual battery performance depends on usage and ambient environment.
- The battery level may not be displayed correctly after you replace the batteries. In this case, place the handset on the base unit or charger and let it charge for at least 7 hours.

## Controls

### Handset

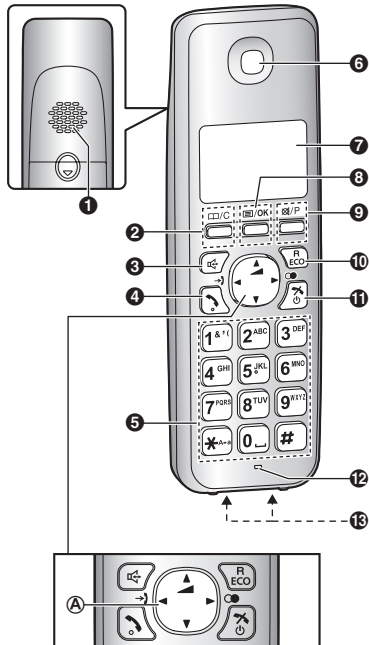

- 1 Speaker
- 2 [☎/C] (Phonebook/Clear)
- 3 [☎] (Speakerphone)
- 4 [☎] (Talk)
- 5 Dial keypad
- 6 Receiver
- 7 Display
- 8 [☰/OK] (Menu/OK)
- 9 [☒/P] (Mute/Pause)

### 10 [R/ECO]

R: Recall/Flash

ECO: Eco mode shortcut key

### 11 [⏻] (Off/Power)

### 12 Microphone

### 13 Charge contacts

### A Navigator key

- [▲], [▼], [◀], or [▶]: Scroll through various lists and items.
- [◀] (Volume: [▲] or [▼]): Adjust the receiver or speaker volume while talking.
- [◀] (☎): Caller list: View the caller list.
- [▶] (●): Redial: View the redial list.

### Base unit

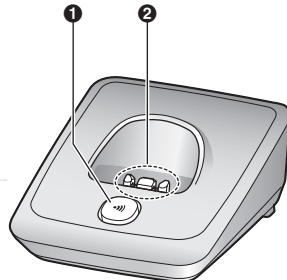





### 1 [☎] (Locator)

### 2 Charge contacts

## Display

### Handset display items

Item	Meaning
	Range status: The more bars visible, the closer the handset is to the base unit. <ul style="list-style-type: none"> <li>● When  is flashing: Handset is searching for base unit. (page 27)</li> </ul>

Item	Meaning
	Handset is accessing base unit (intercom*1, paging, changing base unit settings, etc.).
	Handset is on an outside call. <ul style="list-style-type: none"> <li>When flashing slowly: The call is put on hold.</li> <li>When flashing rapidly: An incoming call is now being received.</li> </ul>
ECO	The base unit transmission power is set to "Low". (page 12)
	Battery level
	Alarm is on. (page 19)
[P]	Privacy mode is on.*1 (page 18)
	New voice mail message received.*2 (page 22)
[IN USE]	Someone is using the line.*1

\*1 KX-TG2712

\*2 Voice mail subscribers only

## Turning the power on/off

### Power on

Press  for about 1 second.

### Power off

Press  for about 2 seconds.







## Initial settings

### Symbol meaning:







Example: [↕]: "Off"

Press [▼] or [▲] to select the words in quotations.







## Display language

- [/OK]
- [↕]: "Handset Setup" → [/OK]
- [↕]: "Display Setup" → [/OK]
- [↕]: "Select Language" → [/OK]
- [↕]: Select your desired language. → [/OK] → [

### Note:

- If you select a language you cannot read: [] → [/OK] → [▲] 3 times → [/OK] → [▼] 3 times → [/OK] 2 times → [↕]: Select your desired language. → [/OK] → [

## Date and time

- [/OK]
- [↕]: "Handset Setup" → [/OK]
- [↕]: "Set Date & Time" → [/OK]
- Enter the current date, month, and year.  
Example: 15 July, 2012  
[0] [5] [0] [7] [1] [2]
- Enter the current hour and minute.  
Example: 9:30  
[0] [9] [3] [0]
  - You can select 24-hour or 12-hour clock format ("AM" or "PM") by pressing .
- [/OK] → [

### Note:



- The date and time may be incorrect after a power failure. In this case, set the date and time again.

## Dialling mode

If you cannot make calls, change this setting according to your telephone line service. The default setting is "Tone".

"Tone": For tone dial service.

"Pulse": For rotary/pulse dial service.

- [/OK]
- [↕]: "Base Unit Setup" → [/OK]

- 3 [↕]: "Dial Mode" → [OK]
- 4 [↕]: Select the desired setting. → [OK] → [🔌]

### One touch eco mode

The [RECO] button on the handset enables you to activate the eco function with one touch. By activating eco mode, your unit can reduce the base unit transmission power by up to 90 % in standby mode.

You can turn on/off one touch eco mode by just pressing [RECO]. The default setting is "Normal".

- When the one touch eco mode is on: "Low" is temporarily displayed and "ECO" is shown on the handset display.
- When the one touch eco mode is off: "Normal" is temporarily displayed and "ECO" goes off from the handset display.

#### Note:

- When there is another cordless phone nearby and it is in use, the base unit transmission power may not be reduced. (KX-TG2712)
- Activating one touch eco mode reduces the range of the base unit in standby mode.
- If you set the repeater mode to "On" (page 19), one touch eco mode is cancelled.

### Making calls

- 1 Lift the handset and dial the phone number.
  - To correct a digit, press [⏏/C].
- 2 [↶]
- 3 When you finish talking, press [📞] or place the handset on the base unit or charger.

### Using the speakerphone

- 1 Dial the phone number and press [📞].
  - Speak alternately with the other party.
- 2 When you finish talking, press [📞].

#### Note:

- For best performance, use the speakerphone in a quiet environment.
- To switch back to the receiver, press [📞]/ [↶].

### Adjusting the receiver or speaker volume

Press [▲] or [▼] repeatedly while talking.

### Making a call using the redial list

The last 10 phone numbers dialed are stored in the redial list (each 24 digits max.).

- 1 [▶] (●)
- 2 [↕]: Select the desired phone number.
- 3 [↶]

### Erasing a number in the redial list

- 1 [▶] (●)
- 2 [↕]: Select the desired phone number.  
→ [☒/OK] 2 times
- 3 [↕]: "Yes" → [☒/OK] → [📞]

### Pause (for PBX/long distance service users)

A pause is sometimes required when making calls using a PBX or long distance service.

When storing a calling card access number and/or PIN in the phonebook, a pause is also needed (page 15).

**Example:** If you need to dial the line access number "0" when making outside calls with a PBX:

- 1 [0] → [☒/P]
- 2 Dial the phone number. → [↶]

#### Note:

- A 3 second pause is inserted each time [☒/P] is pressed.

### Answering calls

- 1 Lift the handset and press [↶] or [📞] when the unit rings.
  - You can also answer the call by pressing any dial key from [0] to [9], [☒], or [#]. (**Any key answer feature**)
- 2 When you finish talking, press [📞] or place the handset on the base unit or charger.

### Auto talk

You can answer calls simply by lifting the handset off the base unit or charger. You do not need to press [↶]. To turn this feature on, see page 17.

### Adjusting the handset ringer volume

- **While the handset is ringing for an incoming call:**  
Lift the handset and press [▲] or [▼] repeatedly to select the desired volume.
- **Programming the volume beforehand:**
  - 1 [☒/OK]
  - 2 [↕]: "Handset Setup" → [☒/OK]
  - 3 [↕]: "Ringer Setup" → [☒/OK]
  - 4 [↕]: "Ringer Volume" → [☒/OK]
  - 5 [↕]: Select the desired volume.
  - 6 [☒/OK] → [📞]

## Making/Answering Calls

### Temporary handset ringer off

While the handset is ringing for a call, you can turn the ringer off temporarily by pressing [🔇].

## Useful features during a call

### Hold

This feature allows you to put an outside call on hold.

- 1 Press [📞/OK] during an outside call.
- 2 [📞]: "Hold" → [📞/OK]
- 3 To release hold, press [📞].
  - Another handset user can take the call by pressing [📞]. (KX-TG2712)

#### Note:

- If a call is kept on hold for more than 9 minutes, the call rings at your handset again. After 1 additional minute on hold, the call is disconnected.
- If another phone is connected to the same line, you can also take the call by lifting its handset.

### Mute

While mute is turned on, you can hear the other party, but the other party cannot hear you.

- 1 Press [🔇/P] during conversation.
- 2 To return to the conversation, press [🔇/P] again.

### Recall/flash

[R/ECO] allows you to use the special features of your host PBX such as transferring an extension call, or accessing optional telephone services.

#### Note:

- To change the recall/flash time, see page 18.

### For call waiting or Call Waiting Caller ID service users

To use call waiting or Call Waiting Caller ID, you must first subscribe with your service provider/telephone company.

This feature allows you to receive calls while you are already talking on the phone. If you receive a call while on the phone, you will hear a call waiting tone.

**If you subscribe to both Caller ID and Call Waiting with Caller ID services**, the 2nd caller's information is displayed after you hear the call waiting tone on the handset.

- 1 Press [R/ECO] to answer the 2nd call.
- 2 To switch between calls, press [R/ECO].

#### Note:

- Please contact your service provider/telephone company for details and availability of this service in your area.

### Temporary tone dialling (for rotary/pulse service users)

You can temporarily switch the dialling mode to tone when you need to access touch-tone services (for example, answering services, telephone banking services, etc.). Press [📞] before entering access numbers which require tone dialling.

### Call share

**Available for:**  
KX-TG2712

You can join an existing outside call. To join the conversation, press [📞] when the other handset is on an outside call.

#### Note:

- To prevent other users from joining your conversations with outside callers, turn the privacy mode on (page 18).

## Handset phonebook

The phonebook allows you to make calls without having to dial manually. You can add 50 names and phone numbers.

### Adding entries

- 1 [☐/C] → [☑/OK]
- 2 [↕]: "New Entry" → [☑/OK]
- 3 Enter the party's name (16 characters max.). → [☑/OK]
  - You can change the character entry mode by pressing [☒/P] (page 24).
- 4 Enter the party's phone number (24 digits max.). → [☑/OK]
- 5 [↕]: "Save" → [☑/OK]
  - To add other entries, repeat from step 3.
- 6 [✕/⏻]

### Finding and calling from a phonebook entry

#### Scrolling through all entries

- 1 [☐/C]
- 2 [↕]: Select the desired entry.
  - You can scroll through the phonebook entry by pressing and holding [▼] or [▲].
- 3 [↶]

#### Searching by first character

- 1 [☐/C]
  - Change the character entry mode if necessary:  
[☒/P] → [↕]: Select the character entry mode. → [☑/OK]
- 2 Press the dial key (0 to 9) which contains the character you are searching for (page 24).
  - Press the same dial key repeatedly to display the first entry corresponding to each character located on that dial key.

- If there is no entry corresponding to the character you selected, the next entry is displayed.

- 3 [↕]: Scroll through the phonebook if necessary.
- 4 [↶]

### Editing entries

- 1 Find the desired entry (page 15). → [☑/OK]
- 2 [↕]: "Edit" → [☑/OK]
- 3 Edit the name if necessary (16 characters max.; page 24). → [☑/OK]
- 4 Edit the phone number if necessary (24 digits max.). → [☑/OK]
- 5 [↕]: "Save" → [☑/OK]
- 6 [✕/⏻]

### Erasing entries

- 1 Find the desired entry (page 15). → [☑/OK]
- 2 [↕]: "Erase" → [☑/OK]
- 3 [↕]: "Yes" → [☑/OK] → [✕/⏻]

## Copying phonebook entries

Available for:  
KX-TG2712

You can copy phonebook entries between 2 handsets.

### Copying an entry

- 1 Find the desired entry (page 15). → [☑/OK]
- 2 [↕]: "Copy" → [☑/OK]

## Phonebook

---

- 3 Enter the handset number you wish to send the phonebook entry to.
  - When an entry has been copied, “Completed” is displayed.
  - To continue copying another entry:  
[↕]: “Yes” → [☒/OK] → [↕]:  
Select the desired entry. → [☒/OK]
- 4 [✕⏻]

---

### Copying all entries







- 1 [☐/C] → [☒/OK]
- 2 [↕]: “Copy All” → [☒/OK]
- 3 Enter the handset number you wish to send the phonebook entry to.
  - When all entries have been copied, “Completed” is displayed.
- 4 [✕⏻]



## Programmable settings

You can customise the unit by programming the following features using the handset.

### Scrolling through the display menus

- 1 **[/OK]**
- 2 Press [**▼**] or [**▲**] to select the desired main menu. → [**/OK**]
- 3 Press [**▼**] or [**▲**] to select the desired item in sub-menu 1. → [**/OK**]  
 • In some cases, you may need to select from sub-menu 2. → [**/OK**]
- 4 Press [**▼**] or [**▲**] to select the desired setting. → [**/OK**]  
 • This step may vary depending on the feature being programmed.  
 • To exit the operation, press [****].

#### Note:

- In the following table, < > indicates the default settings.
- In the following table,  indicates the reference page number.
- Display menu order and sub-menu may vary depending on your model.

Main menu	Sub-menu 1	Sub-menu 2		
Caller List	-	-	20	
Intercom* <sup>1</sup>	-	-	23	
Ph.Book Setup	New Entry	-	15	
	Copy All* <sup>1</sup>	-	16	
Handset Setup	Set Date & Time* <sup>2</sup>	-	11	
	Alarm <Off>	-	18	
	Ringer Setup	Ringer Volume <Level 6>		13
		Ringtone* <sup>3</sup> , * <sup>4</sup> <Ringtone 1>		-
	Display Setup	Select Language <English>		11
		Contrast <Level 3>		-
	Register H.set	-	29	
	Keytones* <sup>5</sup> <On>	-	-	
Auto Talk* <sup>6</sup> <Off>	-	13		

## Programming

Main menu	Sub-menu 1	Sub-menu 2	
Base Unit Setup*2	First Ring*7 <On>	—	—
	Dial Mode <Tone>	—	11
	Recall/Flash*8 <400 msec.>	—	14
	Privacy Mode*1, *9 <Off>	—	—
	Base Unit PIN	—	29
	Repeater Mode <Off>	—	19

\*1 KX-TG2712

\*2 If you program these settings using one of the handsets, you do not need to program the same item using another handset. (KX-TG2712)

\*3 The ringer tone may continue to play for several seconds even if the caller has already hung up. You may either hear a dial tone or no one on the line when you answer the call.

\*4 The preset melodies in this product are used with permission of © 2011 Copyrights Vision Inc.

\*5 Turn this feature off if you prefer not to hear key tones while you are dialling or pressing any keys, including confirmation tones and error tones.

\*6 If you subscribe to a Caller ID service and want to view the caller's information after lifting up the handset to answer a call, turn off this feature.

\*7 If you do not want the unit to ring before the caller information is received, set to "Off". (Caller ID subscribers only)

You can only remove the first ring if the unit rings two times or more by default, which depends on your service provider/telephone company.

\*8 The recall/flash time depends on your telephone exchange or host PBX. Contact your PBX supplier if necessary.

\*9 To prevent other users from joining your conversations with outside callers, turn this feature on.

## Special programming

### Alarm

An alarm sounds at the set time for 3 minutes once or daily. Alarm can be set for each handset.

#### Important:

- Set the date and time beforehand (page 11).

1

2 : "Handset Setup" →

3 : "Alarm" →

4 : Select the desired alarm option. →

"Off"

Turns alarm off. Go to step 8.

"Once"

An alarm sounds once at the set time.

**“Daily”**

An alarm sounds daily at the set time.  
Go to step 6.

- 5 Enter the desired date and month.
- 6 Set the desired time. → [ /OK ]
- 7 [ ]: Select the desired alarm tone. → [ /OK ]
  - We recommend selecting a different ringer tone from the one used for outside calls.
- 8 [ /OK ] → [ ]
  - When the alarm is set, is displayed.

**Note:**

- To stop the alarm, lift the handset and press [ ] or place the handset on the base unit or charger.
- When the handset is in use, the alarm will not sound until the handset is in standby mode.

## Increasing the range of the base unit

You can increase the signal range of the base unit by using a DECT repeater. Please use only the Panasonic DECT repeater noted on page 4. Contact your Panasonic dealer for details.

**Important:**

- Before registering the repeater to this base unit, you must turn the repeater mode on.
- If you want to register 2 or more repeaters to the base unit, contact an authorised service centre.

## Setting the repeater mode

- 1 [ /OK ]
- 2 [ ]: “Base Unit Setup” → [ /OK ]
- 3 [ ]: “Repeater Mode” → [ /OK ]
- 4 [ ]: Select the desired setting. → [ /OK ] → [ ]

**Note:**

- After turning the repeater mode on or off, may flash on the handset momentarily. This is normal and the handset can be used once stops flashing.

## Registering the DECT repeater (KX-A405) to the base unit

**Note:**

- Please use a repeater that has not yet been registered to another unit. If the repeater is registered to another unit, deregister it first, referring to the Installation Guide for the DECT repeater.

- 1 **Base unit:**  
Press and hold [ ] for about 5 seconds. (No registration tone)
  - The next step must be completed within 90 seconds.
- 2 **DECT repeater:**  
Connect the AC adaptor, then wait until the indicator and indicator light green.
- 3 **Base unit:**  
To exit the registration mode, press [ ].

### Using Caller ID service

#### Important:

- This unit is Caller ID compatible. To use Caller ID features, you must subscribe to a Caller ID service. Contact your service provider/telephone company for details.

### Caller ID features

When an outside call is being received, the caller information is displayed.

Caller information for the last 50 callers is logged in the caller list from the most recent call to the oldest.

- If the unit cannot receive caller information, the following is displayed:
  - “**Out of Area**”: The caller dials from an area which does not provide a Caller ID service.
  - “**Private Caller**”: The caller requests not to send caller information.
- If the unit is connected to a PBX system, caller information may not be properly received. Contact your PBX supplier.

### Missed calls

If a call is not answered, the unit treats it as a missed call and “**Missed Call**” is displayed. This lets you know if you should view the caller list to see who called while you were away.

Even if only one missed call in the caller list is viewed (page 20), “**Missed Call**” disappears from the display. When you receive another new call, “**Missed Call**” is displayed again.

#### Note:

- Even when there are unviewed missed calls, “**Missed Call**” disappears from the standby display if the following operation is performed by one of the registered handsets:
  - Being replaced on the base unit or charger.
  - Pressing [**⏏**].

### Phonebook name display

When caller information is received and it matches a phone number stored in the phonebook, the stored name in the phonebook is displayed and logged in the caller list.

### Caller list

#### Important:

- Only 1 person can access the caller list at a time.
- Make sure the unit’s date and time setting is correct (page 11).

### Viewing the caller list and calling back

- 1 [**⏪**] (→)
- 2 Press [**▼**] to search from the most recent call, or press [**▲**] to search from the oldest call.
- 3 To call back, press [**↶**].  
To exit, press [**⏏**].

#### Note:

- If the entry has already been viewed or answered, “**✓**” is displayed, even if it was viewed or answered using another handset.

### Editing a caller’s phone number before calling back

- 1 [**⏪**] (→)
- 2 [**⏴**]: Select the desired entry. → [**⏏**/OK]
- 3 [**⏴**]: “**Edit and Call**” → [**⏏**/OK]
- 4 Edit the number.
  - Press dial key (**0**) to **add**, [**□□/C**] to **delete**.
- 5 [**↶**]

### Erasing caller information

- 1 [] ()
- 2 []: Select the desired entry. →  
[/OK]
- 3 []: "Erase" or "Erase All" →  
[/OK]
- 4 []: "Yes" → [/OK] → []

---

### Storing caller information to the phonebook



- 1 [] ()
- 2 []: Select the desired entry. →  
[/OK]
- 3 []: "Add Phonebook" → [/OK]
- 4 To store the name, continue from step 3, "Adding entries", page 15.

### Voice mail service

Voice mail is an automatic answering service offered by your service provider/telephone company. After you subscribe to this service, your service provider/telephone company's voice mail system answers calls for you when you are unavailable to answer the phone or when your line is busy. Messages are recorded by your service provider/telephone company, not your telephone.

When you have new messages,  is displayed on the handset if message indication service is available. Please contact your service provider/telephone company for details of this service.

#### Important:

- If  still remains on the display even after you have listened to new messages, turn it off by pressing and holding  for 2 seconds.

## Intercom

Available for:  
KX-TG2712

Intercom calls can be made between handsets.

### Note:

- When paging the handset, the paged handset beeps for 1 minute.
- If you receive an outside call while talking on the intercom, you hear 2 tones. To answer the call, press [📞], then press [📞].

## Making an intercom call

- 1 [📞/OK]
- 2 [📞]: "Intercom" → [📞/OK]
- 3 To page a specific handset, enter the handset number.
  - To stop paging, press [📞].
- 4 When you finish talking, press [📞].

## Answering an intercom call

- 1 Press [📞] to answer the page.
- 2 When you finish talking, press [📞].

## Handset locator

You can locate a misplaced handset by paging it.

- 1 **Base unit:** Press [📞].
  - All registered handsets beep for 1 minute.
- 2 To stop paging:  
**Base unit:** Press [📞].  
**Handset:** Press [📞].

## Transferring calls, conference calls

Available for:  
KX-TG2712

Outside calls can be transferred or a conference call with an outside party can be made between 2 handsets.

- 1 During an outside call, press [📞/OK].
  - 2 [📞]: "Intercom" → [📞/OK]
    - 📞 flashes to indicate the outside call is on hold.
  - 3 Enter the desired handset number you want to transfer to.
  - 4 Wait for the paged party to answer.
    - If the paged party does not answer, press [📞] to return to the outside call.
  - 5 **To complete the transfer:**  
Press [📞].
    - The outside call is being routed to the destination unit.
- To establish a conference call:**  
Press [3].
- To leave the conference, press [📞]. The other 2 parties can continue the conversation.
  - To put the outside call on hold, press [📞/OK]. → [📞]: "Hold" → [📞/OK]  
To resume the conference, press [3].

## Answering a transferred call

Press [📞] to answer the page.

### Character entry

The dial keys are used to enter characters and numbers. Each dial key has multiple characters assigned to it. The characters that can be entered depend on the character entry mode (page 24).

- Press [◀] or [▶] to move the cursor left or right.
- Press dial keys to enter characters and numbers.
- Press [□□/C] to erase the character or number highlighted by the cursor. Press and hold [□□/C] to erase all characters or numbers.
- Press [A→a] to switch between uppercase and lowercase.
- To enter another character located on the same dial key, press [▶] to move the cursor to the next space, then press the appropriate dial key.

### Character entry modes

The available character entry modes are Alphabet (ABC), Numeric (0-9), Greek (ΑΒΓ), Extended 1 (ÅÄÅ), Extended 2 (ŠŠŠ), and Cyrillic (АБВ). When in these entry modes except Numeric, you can select which character is entered by pressing a dial key repeatedly.

**When the unit displays the character entry screen:**

[☒/P] → [↕]: Select a character entry mode. → [☒/OK]

**Note:**

- ◻ in the following tables represents a single space.

#### Alphabet character table (ABC)

0	1	2	3	4	5	6	7	8	9
◻ 0	◻ # & ' ( ) * , - . / 1	A B C 2	D E F 3	G H I 4	J K L 5	M N O 6	P Q R S 7	T U V 8	W X Y Z 9
		a b c 2	d e f 3	g h i 4	j k l 5	m n o 6	p q r s 7	t u v 8	w x y z 9

#### Numeric entry table (0-9)

0	1	2	3	4	5	6	7	8	9
0	1	2	3	4	5	6	7	8	9

#### Greek character table (ΑΒΓ)

0	1	2	3	4	5	6	7	8	9
◻ 0	◻ # & ' ( ) * , - . / 1	A B Γ 2	Δ E Z 3	H Θ I 4	K Λ M 5	N Ξ O 6	Π Ρ Σ 7	T Υ Φ 8	X Ψ Ω 9



## Extended 1 character table (AĂÄ)

0	1	2	3	4	5	6	7	8	9
0	~ # & ' ( ) * , - . / 1	A Ä Á Å Ã Ä Å Æ B C Ç 2	D E È É Ê Ë Ë Ì 3	G Ğ H I Ì Í Î Ï Ñ Ò Ó Ô Õ ø 6	J K L 5	M N Ñ O Ò Ó Ô Õ Ö ø 6	P Q R S Ş ß 7	T U Û Ü Ú Û Ü V 8	W Ŵ X Y ŷ Z 9
		a à á â ã ä å æ b c ç 2	d e è é ê ë ë ì 3	g ğ h i ì í î ï ñ ò ó ô õ ø 6	j k l 5	m n ñ o ò ó ô õ ö ø 6	p q r s ş ş ß 7	t u ù ú û ü ü v 8	w ŵ x y ŷ z 9

- The following are used for both uppercase and lowercase: ø ş ŵ ŷ

## Extended 2 character table (SŠŠ)

0	1	2	3	4	5	6	7	8	9
0	~ # & ' ( ) * , - . / 1	A Á Ā Ā B C Ā Č 2	D Ď E É Ě Ě F 3	G H I í 4	J K L Ĺ Ľ Ľ 5	M N Ń Ń O Ó Ō Ő 6	P Q R Ř Ŕ Ŕ Ś Š 7	T Ť U Ú Ů Ů ú v 8	W X Y ŷ Ÿ Z Ž Ž Ž 9
		a á ā Ā b c Ā č 2	d ě e é ě ě f 3	g h i í 4	j k l Ĺ Ľ Ľ 5	m n Ń ň o ó ő ő 6	p q r ř ŕ ŕ ś š 7	t ť u ú ů ů ú v 8	w x y ŷ ŷ z ž ž ž 9

- The following are used for both uppercase and lowercase:

Ā Ć Č Ě Ĺ Ľ Ľ Ń Ŕ Ś Š Ů ŷ Ž Ž Ž

## Cyrillic character table (АБВ)

0	1	2	3	4	5	6	7	8	9
0	0 Г Є І І Ў	А Б В	Д Е Ж	И Й К	М Н О	Р С Т	Ф Х Ц	Ш Щ	Ъ Э Ю
	~ # & ' ( ) * , - . / 1	Г	З	Л	П	У	Ч	Ъ Ы	Я
		2	3	4	5	6	7	8	9

### Error messages

Display message	Cause/solution
Failed	<ul style="list-style-type: none"><li>● Phonebook copy failed (page 15). Confirm the other handset (the receiver) is in standby mode and try again.</li></ul>
Incomplete	<ul style="list-style-type: none"><li>● The receiver's phonebook memory is full. Erase the unwanted phonebook entries from the other handset (the receiver) and try again.</li></ul>
Memory Full	<ul style="list-style-type: none"><li>● The phonebook memory is full. Erase unwanted entries (page 15).</li></ul>
No link to base. Reconnect AC adaptor.	<ul style="list-style-type: none"><li>● The handset has lost communication with the base unit. Move closer to the base unit and try again.</li><li>● Unplug the base unit's AC adaptor to reset the unit. Reconnect the adaptor and try again.</li><li>● The handset's registration may have been cancelled. Re-register the handset (page 29).</li></ul>

---

### Troubleshooting

If you still have difficulties after following the instructions in this section, disconnect the base unit's AC adaptor and turn off the handset, then reconnect the base unit's AC adaptor and turn on the handset.

---

#### General use



Problem	Cause/solution
The handset does not turn on even after installing charged batteries.	<ul style="list-style-type: none"><li>● Place the handset on the base unit or charger to turn on the handset.</li></ul>
The unit does not work.	<ul style="list-style-type: none"><li>● Make sure the batteries are installed correctly (page 8).</li><li>● Fully charge the batteries (page 8).</li><li>● Check the connections (page 8).</li><li>● Unplug the base unit's AC adaptor to reset the unit and turn off the handset. Reconnect the adaptor, turn on the handset and try again.</li><li>● The handset has not been registered to the base unit. Register the handset (page 29).</li></ul>
The handset display is blank.	<ul style="list-style-type: none"><li>● The handset is not turned on. Turn the power on (page 11).</li></ul>

Problem	Cause/solution
I cannot hear a dial tone.	<ul style="list-style-type: none"> <li>● Make sure that you are using the supplied telephone line cord. Your old telephone line cord may have a different wiring configuration.</li> <li>● The base unit's AC adaptor or telephone line cord is not connected. Check the connections.</li> <li>● Disconnect the base unit from the telephone line and connect the line to a known working telephone. If the working telephone operates properly, contact our service personnel to have the unit repaired. If the working telephone does not operate properly, contact your service provider/telephone company.</li> </ul>
I cannot use the intercom or phonebook copy feature.	<ul style="list-style-type: none"> <li>● These features are available between the handsets. Although the handset displays "Intercom", "Copy All", or "Copy", these features are not available for single handset models.</li> </ul>

### Programmable settings

Problem	Cause/solution
The display is in a language I cannot read.	<ul style="list-style-type: none"> <li>● Change the display language (page 11).</li> </ul>
I cannot activate the eco mode.	<ul style="list-style-type: none"> <li>● You cannot set eco mode when you set the repeater mode "On". If required, set the repeater mode to "Off" (page 19).</li> </ul>

### Battery recharge

Problem	Cause/solution
The handset beeps and/or  flashes.	<ul style="list-style-type: none"> <li>● Battery charge is low. Fully charge the batteries (page 8).</li> </ul>
I fully charged the batteries, but <ul style="list-style-type: none"> <li>–  still flashes or</li> <li>– the operating time seems to be shorter.</li> </ul>	<ul style="list-style-type: none"> <li>● Clean the battery ends (+, -) and the charge contacts with a dry cloth and charge again.</li> <li>● It is time to replace the batteries (page 8).</li> </ul>

### Making/answering calls, intercom

Problem	Cause/solution
 is flashing.	<ul style="list-style-type: none"> <li>● The handset is too far from the base unit. Move closer.</li> <li>● The base unit's AC adaptor is not properly connected. Reconnect AC adaptor to the base unit.</li> <li>● The handset is not registered to the base unit. Register it (page 29).</li> <li>● Activating one touch eco mode reduces the range of the base unit in standby mode. If required, turn eco mode off (page 12).</li> </ul>

## Useful Information

Problem	Cause/solution
Noise is heard, sound cuts in and out.	<ul style="list-style-type: none"><li>● You are using the handset or base unit in an area with high electrical interference. Re-position the base unit and use the handset away from sources of interference.</li><li>● Move closer to the base unit.</li><li>● If you use a DSL/ADSL service, we recommend connecting a DSL/ADSL filter between the base unit and the telephone line jack. Contact your DSL/ADSL provider for details.</li></ul>
The handset does not ring.	<ul style="list-style-type: none"><li>● The ringer volume is turned off. Adjust ringer volume (page 13).</li></ul>
I cannot make a call.	<ul style="list-style-type: none"><li>● The dialling mode may be set incorrectly. Change the setting (page 11).</li></ul>

## Caller ID

Problem	Cause/solution
Caller information is not displayed.	<ul style="list-style-type: none"><li>● You must subscribe to a Caller ID service. Contact your service provider/telephone company for details.</li><li>● If your unit is connected to any additional telephone equipment, remove and plug the unit directly into the wall jack.</li><li>● If you use a DSL/ADSL service, we recommend connecting a DSL/ADSL filter between the base unit and the telephone line jack. Contact your DSL/ADSL provider for details.</li><li>● Other telephone equipment may be interfering with this unit. Disconnect the other equipment and try again.</li></ul>
Caller information is slow to display.	<ul style="list-style-type: none"><li>● Depending on your service provider/telephone company, the unit may display the caller's information at the 2nd ring or later. Set the first ring to "OFF" (page 18).</li><li>● Move closer to the base unit.</li></ul>
The name stored in the phonebook is not fully displayed while an outside call is being received.	<ul style="list-style-type: none"><li>● Edit the phonebook entry name to fit in 1 line of text (page 15).</li></ul>

## Liquid damage

Problem	Cause/solution
Liquid or other form of moisture has entered the handset/base unit.	<ul style="list-style-type: none"><li>● Disconnect the AC adaptor and telephone line cord from the base unit. Remove the batteries from the handset and leave to dry for at least 3 days. After the handset/base unit are completely dry, reconnect the AC adaptor and telephone line cord. Insert the batteries and charge fully before use. If the unit does not work properly, contact an authorised service centre.</li></ul>

### Caution:

- To avoid permanent damage, do not use a microwave oven to speed up the drying process.

---

## Registering a handset to the base unit

- 1 **Handset:**  
[/OK]
  - 2 []: “Handset Setup” → [/OK]
  - 3 []: “Register H.set” → [/OK]
  - 4 **Base unit:**  
Press and hold [] for about 5 seconds. (No registration tone)
    - If all registered handsets start ringing, press [] again to stop, then repeat this step. (KX-TG2712)
    - The next step must be completed within 90 seconds.
  - 5 **Handset:**  
Wait until “Enter Base PIN” is displayed. → Enter the base unit PIN (default: “0000”).  
→ [/OK]
    - If you forget your PIN, contact an authorised service centre.
    - When the handset has been registered successfully, stops flashing.
- 

## Deregistering a handset

- 1 [/OK]
  - 2 []: “Base Unit Setup” → [/OK]
  - 3 [][][] → [/OK]
    - All handsets registered to the base unit are displayed.
  - 4 Enter the desired handset number you want to cancel. → [/OK]
  - 5 []: “Yes” → [/OK]
    - A confirmation tone sounds.
    - The handset does not beep when cancelling its own registration.
  - 6 []
- 

## Changing the base unit PIN (Personal Identification Number)

### Important:

- If you change the PIN, please make note of your new PIN. The unit will not reveal the PIN to you. If you forget your PIN, contact an authorised service centre.
- 1 [/OK]
  - 2 []: “Base Unit Setup” → [/OK]
  - 3 []: “Base Unit PIN” → [/OK]
  - 4 Enter the current 4-digit base unit PIN (default: “0000”).
  - 5 Enter the new 4-digit base unit PIN. → [/OK] → []

## Wall mounting

**Note:**

- Make sure that the wall and the fixing method are strong enough to support the weight of the unit.
- Drive the screws (not supplied) into the wall.

■ **Base unit**

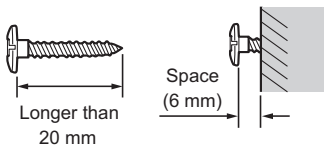
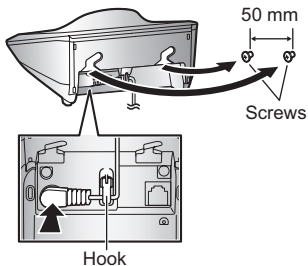

■ **Charger**

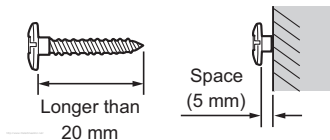
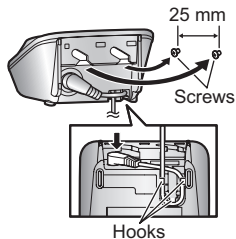

---

**Index**

- A** Alarm: 18
    - Answering calls: 13
    - Auto talk: 13, 17
  - B** Battery: 8, 9
  - C** Call share: 14
    - Call waiting: 14
    - Call Waiting Caller ID: 14
    - Caller ID service: 20
    - Caller list: 20
    - Caller list edit: 20
    - Character entry: 24
    - Conference calls: 23
  - D** Date and time: 11
    - Dialling mode: 11
    - Display
      - Contrast: 17
      - Language: 11
  - E** Eco mode: 12
    - Error messages: 26
  - F** First ring: 18
  - H** Handset
    - Deregistration: 29
    - Locator: 23
    - Registration: 29
    - Hold: 14
  - I** Intercom: 23
  - K** Keytones: 17
  - M** Making calls: 13
    - Missed calls: 20
    - Mute: 14
  - P** Pause: 13
    - Phonebook: 15
    - PIN: 29
    - Power failure: 9
    - Power on/off: 11
    - Privacy mode: 18
  - R** Recall/flash: 14
    - Redialling: 13
    - Repeater: 19
    - Ringer tone: 17
  - S** Speakerphone: 13
  - T** Temporary tone dialling: 14
    - Transferring calls: 23
    - Troubleshooting: 26
  - V** Voice mail: 22
- Volume
- Receiver: 13
  - Ringer (Handset): 13, 17
  - Speaker: 13
- W** Wall mounting: 30

**For your future reference**

We recommend keeping your guarantee card and a record of the following information to assist with any repair under warranty.

Serial No.	Date of purchase
(found on the bottom of the base unit)	
Name and address of dealer	



<b>Hotline Tel. No.: 2313 0666</b>
------------------------------------

**Sole Agent for Hong Kong & Macau:**

Shun Hing Technology Co., Ltd.

Block B, 9/F., Peninsula Centre 67 Mody Road Tsimshatsui East Kowloon,  
Hong Kong

Tel: 2313 0888

Hotline: 2313 0666

Fax: 2368 8068

Email address: [shtec@panasonic.oa.hk](mailto:shtec@panasonic.oa.hk)

Panasonic System Networks Co., Ltd.

1-62, 4-chome, Minoshima, Hakata-ku, Fukuoka 812-8531, Japan

© Panasonic System Networks Co., Ltd. 2012



\*PNQX5416ZA\*

**PNQX5416ZA** TT1012MU0 (D) **HK-2/2**