

ESD PROTECTION DEVICE

STAND-OFF VOLTAGE - 5.0 Volts
POWER DISSIPATION - 50 Watts

GENERAL DESCRIPTION

The L05ESDL5V0NA-4 is ultra low capacitance TVS arrays designed to protect high speed data interfaces. This series has been specifically designed to protect sensitive components which are connected to high-speed data and transmission lines from over voltage caused by ESD (electrostatic discharge), CDE (Cable Discharge Events), and EFT (electrical fast transients).

FEATURES

- Flow-through design
- Protects four I/O lines (Data line)
- Max. peak pulse power: P_{pp}=50w at t_p = 8/20 us.
- Low capacitance: 0.3pF typical (I/O to I/O)
- IEC 61000-4-2, level 4 (ESD), >±15KV(air)
; >±8KV(contact)

MECHANICAL DATA

- Case material: "Green" molding compound UL flammability classification 94V-0 (No Br, Sb, Cl), "Halogen-free"
- Terminals: lead free plating (matte tin finish)
- Component in accordance to RoHs 2002/95/EC

APPLICATION

- High definition multi-media interface (HDMI)
- Digital visual interface (DVI)
- Display prot™ interface
- MDDI ports
- LVDS
- Serial ATA

SLP2510P8

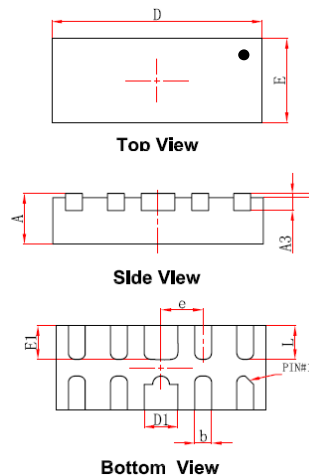

SLP2510P8		
DIM.	MIN.	MAX.
A	0.45	0.55
A1	0.00	0.05
A3	0.152 REF.	
D	2.45	2.55
E	0.95	1.05
D1	0.35	0.45
E1	0.35	0.45
b	0.15	0.25
e	0.50 BSC	
L	0.35	0.45
All dimension in millimeter		

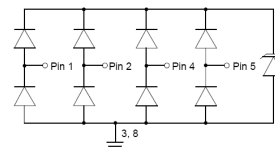

PIN ASSIGNMENT	
1,2,4,5	Input lines
6,7,9,10	NC
3,8	Ground

MAXIMUM RATINGS AND ELECTRICAL CHARACTERISTICS

Ratings at 25°C ambient temperature unless otherwise specified.

ABSOLUTE RATINGS

PARAMETER	SYMBOL	VALUE	UNIT
Peak pulse power (t _p = 8/20us)	P _{pk}	50	W
Peak pulse current (t _p = 8/20us)	I _{pp}	4.5	A
Operating junction temperature range	T _J	-55 to +125	°C
Storage temperature range	T _{STG}	55 to +150	°C
Soldering temperature, t _{max} = 10s	T _L	260	°C

ELECTRICAL CHARACTERISTICS

PARAMETER	TEST CONDITIONS	SYMBOL	MIN	TYP.	MAX	UNIT
Reverse standoff voltage	Any I/O pin to ground	V _{RWM}	--	--	5.0	V
Reverse leakage current	V _{DRM} = 5V	I _{RM}	--	--	1.0	uA
Breakdown voltage	I _R = 1 mA	V _{BR}	6.0	--	--	V
Forward voltage	I _F = 15 mA, pin 3,8 to pin 1,2,4,5 @ T _J = 25°C	V _F	--	0.85	1.1	V
Clamping Voltage	I _{pp} = 4.5A, t _p = 8/20 us	V _C	--	--	10	V
Junction capacitance	VR = 0V, f = 1MHz, between I/O pins	C _J	--	0.3	0.4	pF
	VR = 0V, f = 1MHz, any I/O pin to ground		--	--	0.8	

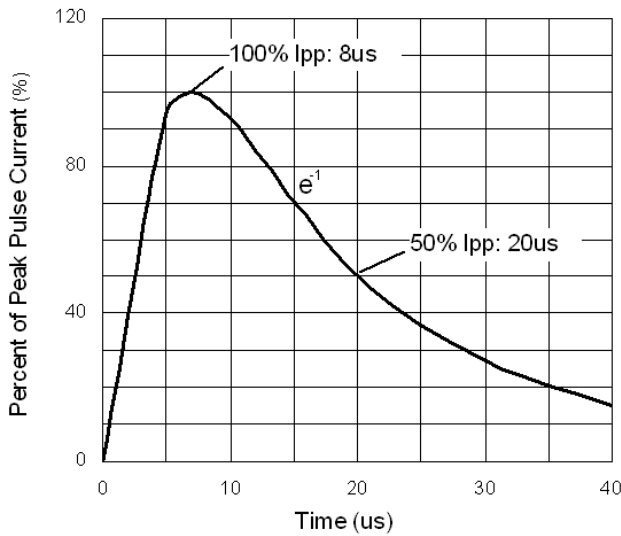

Figure 1. 8/20 us pulse waveform according to IEC 61000-4-5

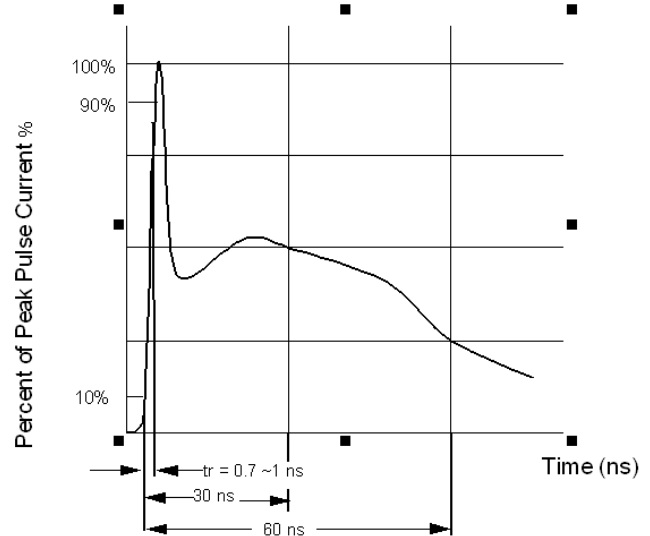

Figure 2. ESD pulse waveform according to IEC 61000-4-2

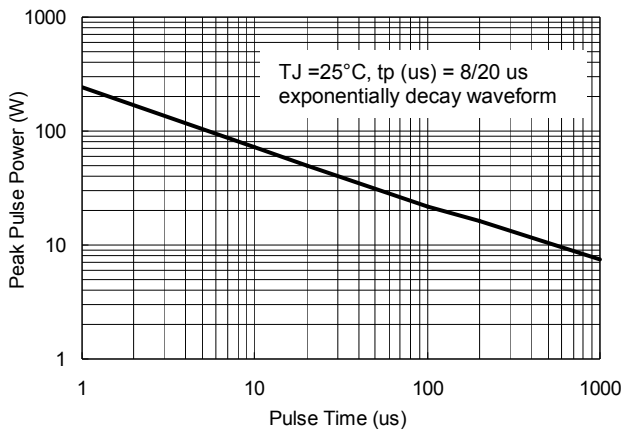

Figure 3. Power Dissipation versus Pulse Time

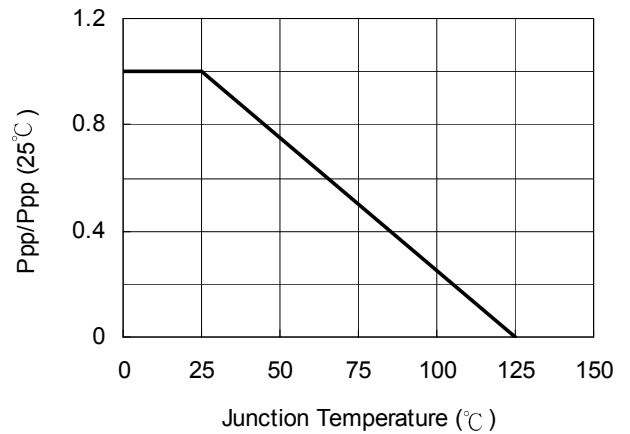

Figure 4. Peak pulse power versus TJ

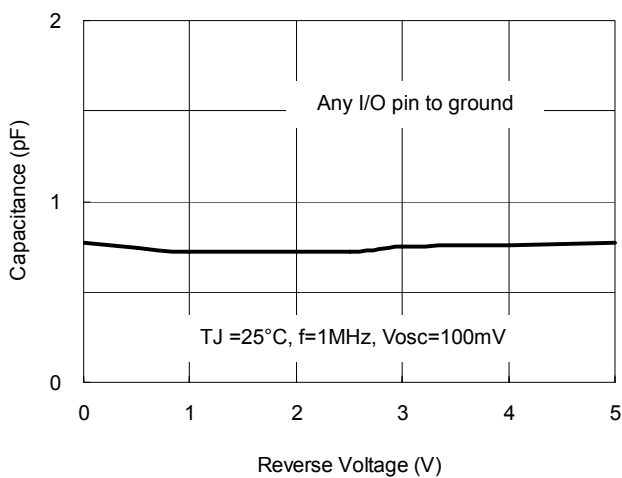

Figure 5. Typical Junction Capacitance

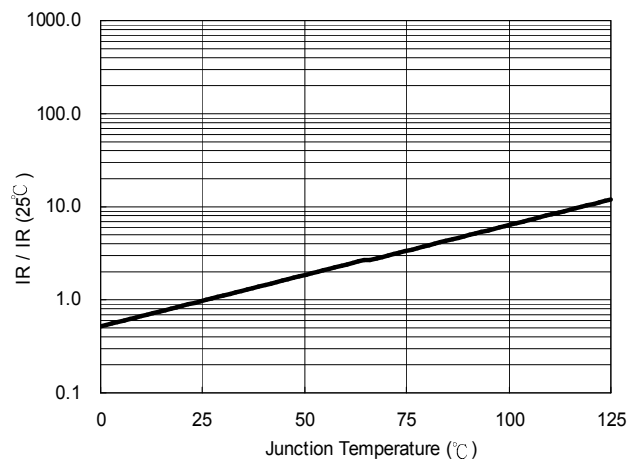

Figure 6. Reverse Leakage Current versus TJ

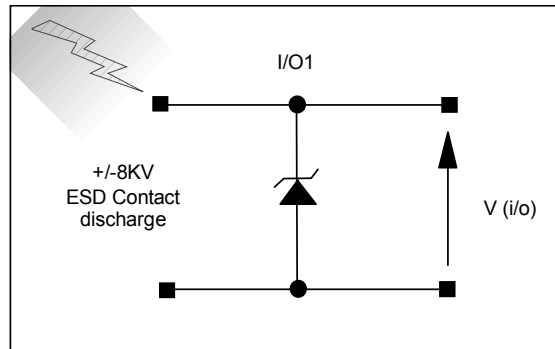

Figure 7. ESD Test Configuration

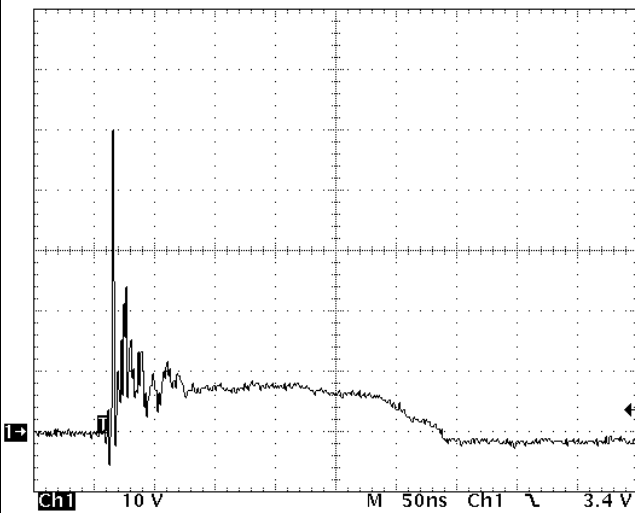

Figure 8. Clamped +8 kV ESD voltage waveform

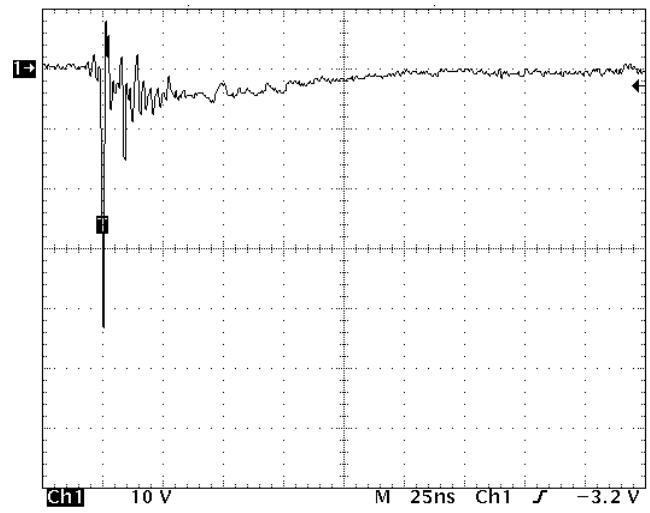

Figure 9. Clamped -8 kV ESD voltage waveform

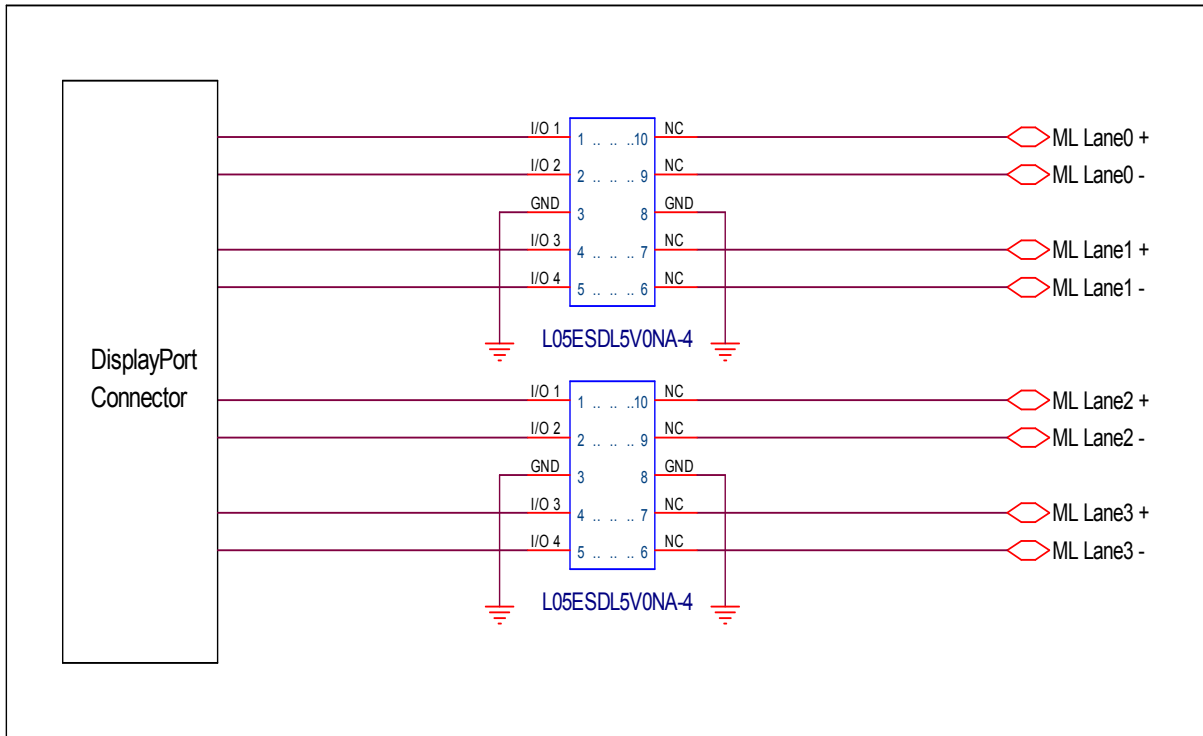

Figure 12. Display Port ESD Protection

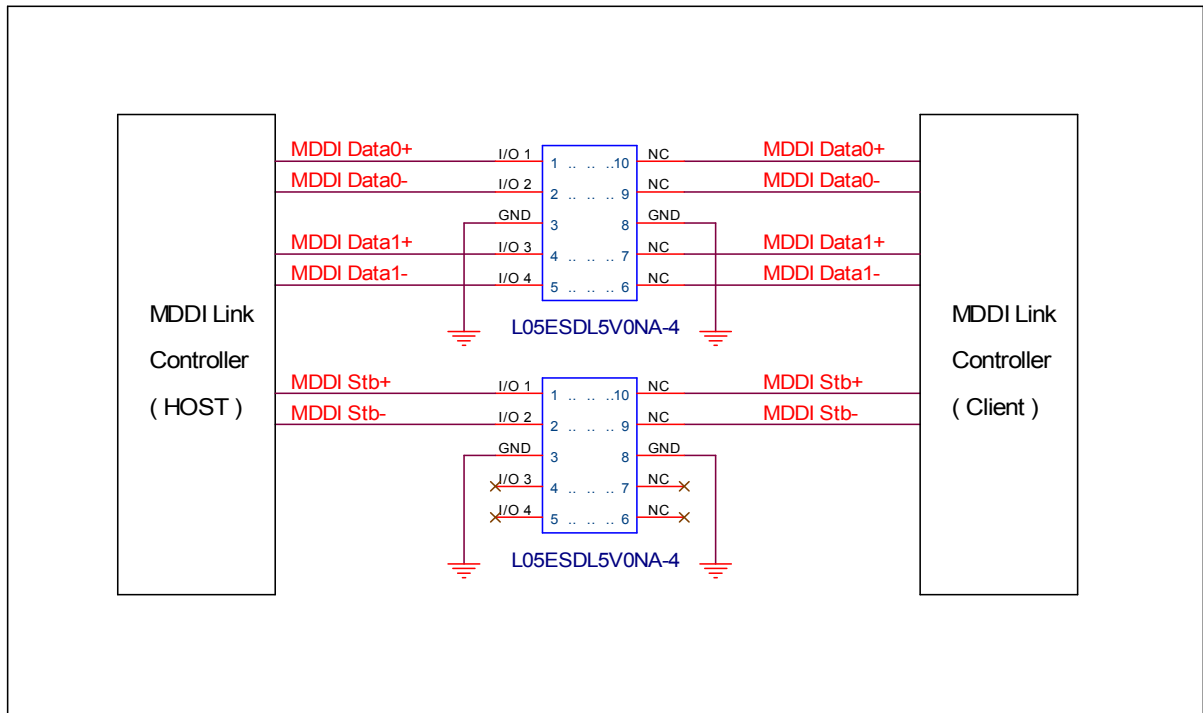

Figure 13. MDDI Interface ESD Protection

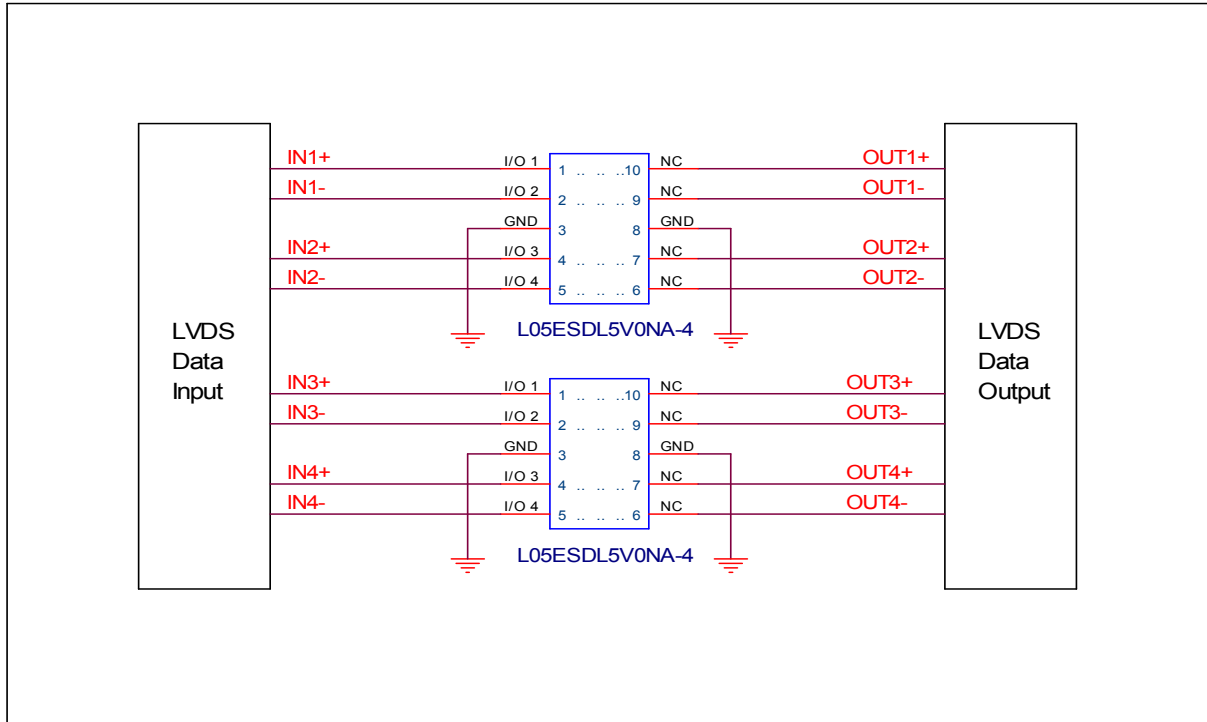

Figure 14. LVDS Interface ESD Protection

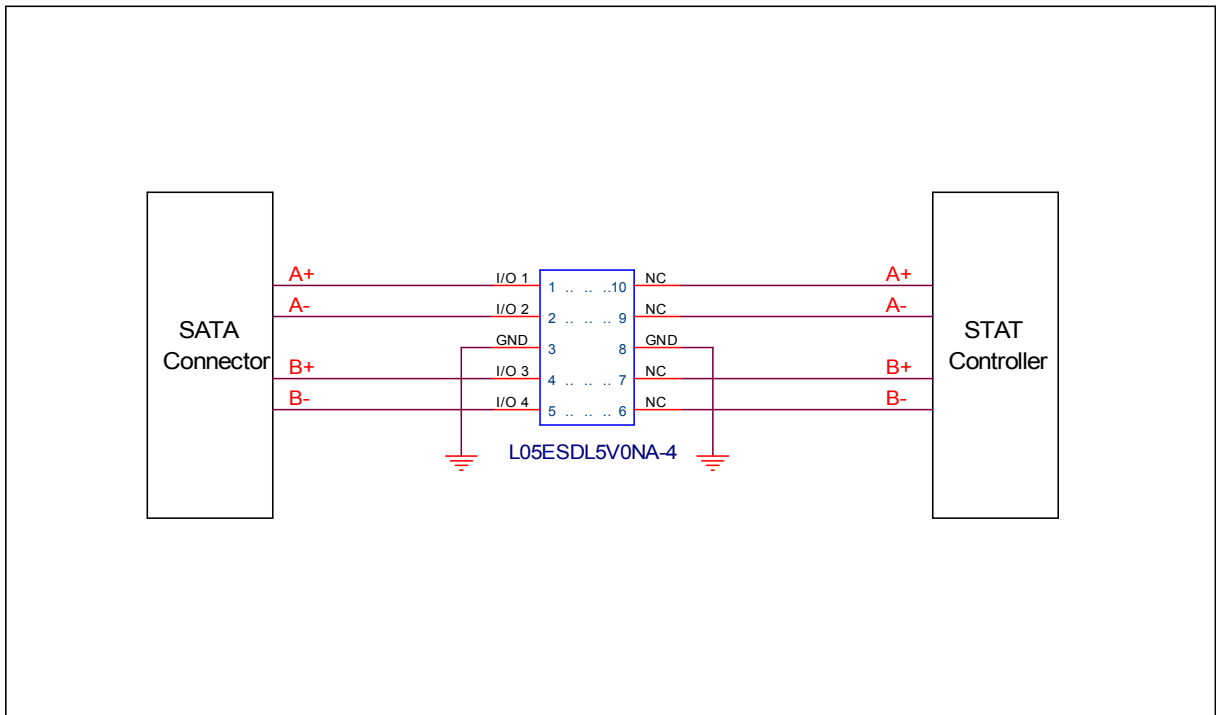
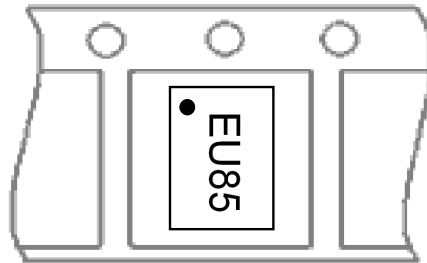

Figure 15. Serial ATA ESD Protection

MARKING AND PACKAGING INFORMATION
L05ESDL5V0NA-4



Marking and Orientation :



Packaging Information :

DEVICE	Q'TY/REEL (PCS)	REEL DIA. (INCH)	Q'TY/BOX (PCS)	Q'TY/CARTON (PCS)
L05ESDL5V0NA-4	3000	7	45000	90K/180K

SLP2510P8 Soldering Pad Layout :

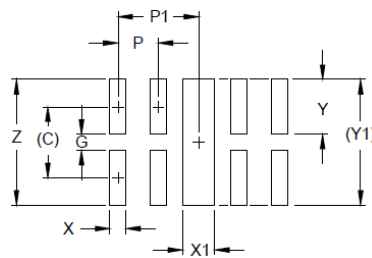

Dim.	Millimeters	Inches
C	(0.875)	(0.034)
G	0.20	0.008
P	0.50	0.020
P1	1.00	0.039
X	0.20	0.008
X1	0.40	0.016
Y	0.68	0.027
Y1	(1.550)	(0.061)
Z	1.55	0.061

Important Notice and Disclaimer

LSC reserves the right to make changes to this document and its products and specifications at any time without notice. Customers should obtain and confirm the latest product information and specifications before final design, purchase or use.

LSC makes no warranty, representation or guarantee regarding the suitability of its products for any particular purpose, nor does LSC assume any liability for application assistance or customer product design. LSC does not warrant or accept any liability with products which are purchased or used for any unintended or unauthorized application.

No license is granted by implication or otherwise under any intellectual property rights of LSC.

LSC products are not authorized for use as critical components in life support devices or systems without express written approval of LSC.