

SERVICE MANUAL

19" LCD Monitor L1940T



THESE DOCUMENTS ARE FOR REPAIR SERVICE INFORMATION ONLY. EVERY REASONABLE EFFORT HAS BEEN MADE TO ENSURE THE ACCURACY OF THIS MANUAL; WE CANNOT GUARANTEE THE ACCURACY OF THIS INFORMATION AFTER THE DATE OF PUBLICATION AND DISCLAIMS RELIABILITY FOR CHANGES, ERRORS OR OMISSIONS.

Table of Contents	
Table of Contents	02
Revision List	03
1. Monitor Specification	04
2. LCD Monitor Description	05
3. Operation Instructions	06
3.1 General Instructions	06
3.2 Control Button	06
3.3 Adjusting The Picture	07
4. Input/Output Specification	09
4.1 Input Signal Connector	09
4.2 Factory Preset Display Modes	11
4.3 Power Supply Requirements	11
5. Panel Specification	12
5.1 General Feature	12
5.2 Optical Characteristics	13
6. Monitor Exploded View	14
7. Block Diagram	15
8. Maintainability	17
9. Schematic	24
9.1 Main Board	24
9.2 Inverter/Power Board	29
10. PCB Layout	31
10.1 Main Board	31
10.2 Inverter/Power Board	32
10.3 Key Board	32
11. White-Balance, Luminance Adjustment	33
12. EDID Content	36
13. BOM List	37
14. Different Parts List	

--	--	--	--

1. Monitor Specifications

LCD Panel	Driving system	TFT Color LCD
	Panel	M190E5-L0A
	Active Area	376.32(H) x 301.056(V) (19.0")
	Pixel pitch	0.294mm(H) x 0.294mm(V)
	Viewing Angles (TYP)	H: 150; V: 130
	Response time (typ.)	8 ms
	Contrast	700:1
	Video	Analog /Digital
Input	Sync. Type	H/V TTL
	H-Frequency	30kHz – 83kHz
	V-Frequency	56Hz – 76Hz
Display Colors	Over 16 million Colors	
Pixel Clock	140MHz	
Max. Resolution	1280 x 1024	
Plug & Play	VESA DDC2B™	
Power Consumption	ON Mode	≤70W
	OFF Mode	<1W
	Sleep Mode	<2W
Power Source	100~240VAC,47~63Hz	
Environmental Considerations	Operating Temp: 5°C to 35°C Storage Temp.: -20°C to 60°C Operating Humidity: 20% to 80%	
Main Dimensions	Unpackaged (W*H*D)	413mm*477mm*265mm
	Packaged (W*H*D)	524mm*513mm*239mm
Weight (N. W.)	Packaged	10.22Kg Unit max
	Unpackaged	8.4Kg Unit max
Altitude	Operating	0 to 12,000 feet
	Non-Operating	0 to 40,000 feet

2. LCD Monitor Description

The LCD Monitor will contain main board, power board, key board and which house the flat panel control logic, brightness control logic and DDC.

The power board will provide AC to DC Inverter voltage to drive the backlight of panel and the main board chips each voltage.

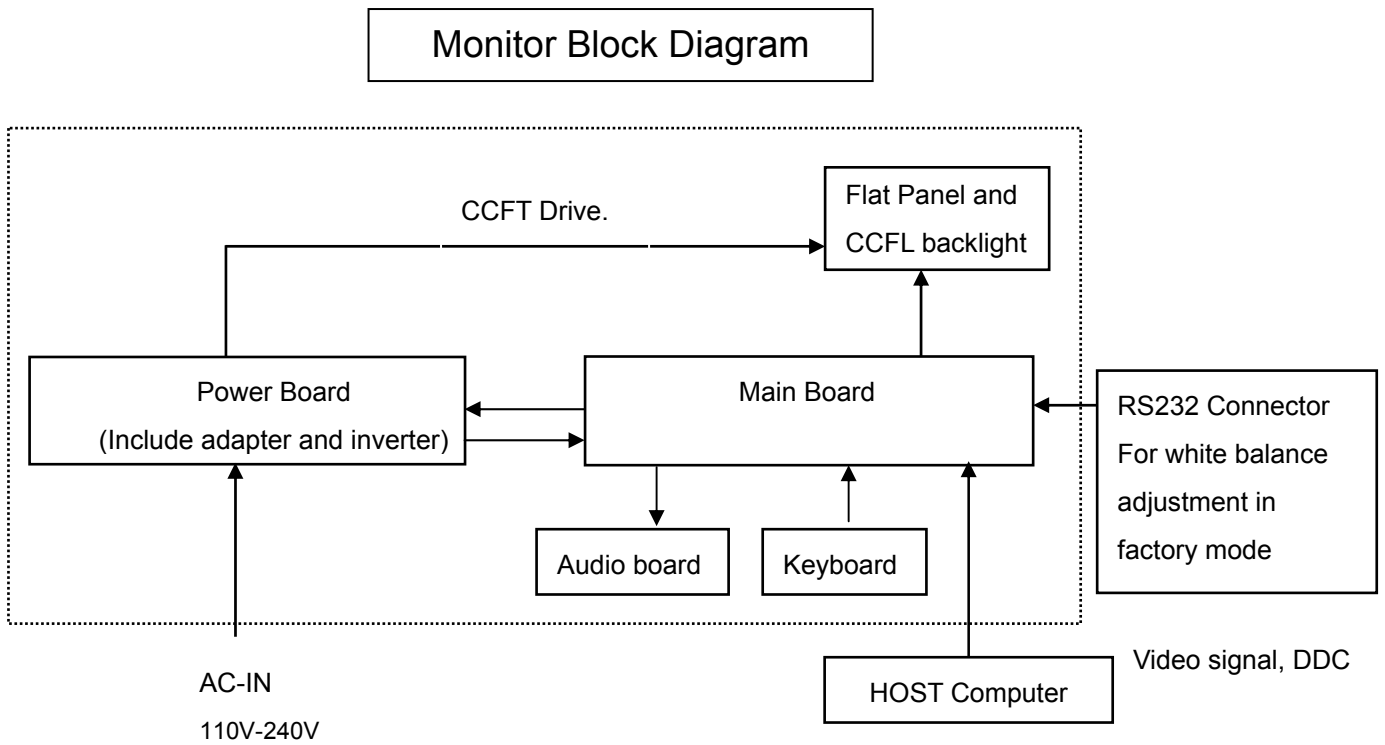

3. Operation Instructions

3.1 General Instructions

Press the power button to turn the monitor on or off. The other control buttons are located at front of the panel. By changing these settings, the picture can be adjusted to your personal performance.

- The power cord should be connected.
- Connect the video cable from the monitor to the computer VGA card.
- Press the power button to turn on the monitor, the power indicator will light up to Green.

3.2 Control Buttons

- **Power Indicator:**

Green — Power On mode.

Orange — Power Saving mode.

Blank —Power Off Mode.

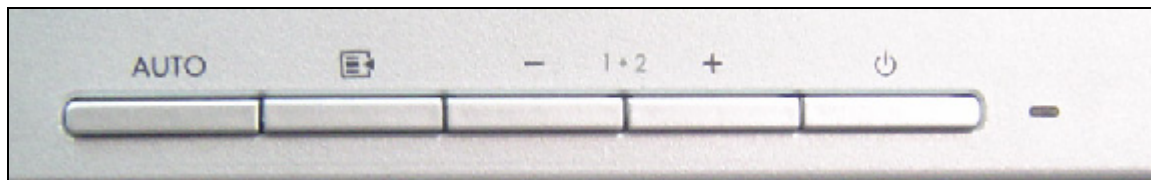

Auto Adjust: Activates the auto adjustment feature for optimum image.

Menu: Opens the ON-Screen Display (OSD) menu.

Minus (-) : 1、 If OSD is on, press to navigate backward through the OSD menu features and decrease adjustment levels.

2、 If OSD is off, press to enable the DVI signal input (available on select models).

plus (+) : 1、 If OSD is on, press to navigate forward through the OSD menu features and increase adjustment levels.

2、 If OSD is off, press to enable the VGA signal input.

Power: Turns the monitor on or off.

3.3 Adjust the Picture

Main Menu

Press the "Menu" button, the Main Menu should be come on the screen of the monitor

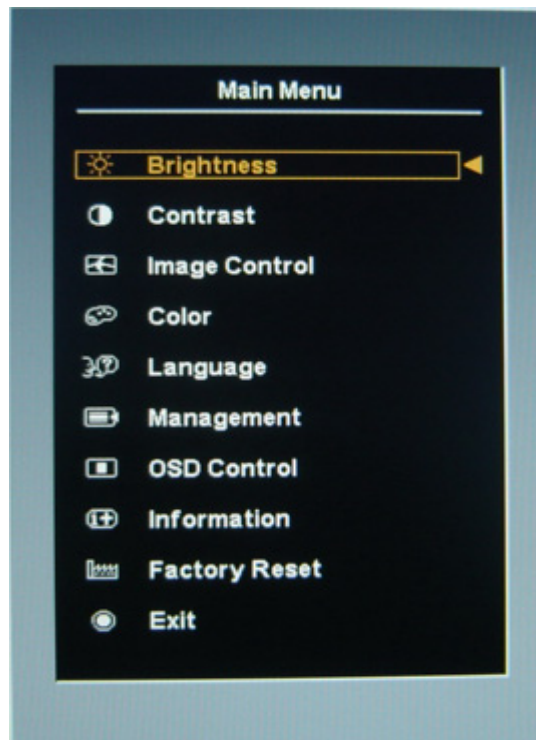





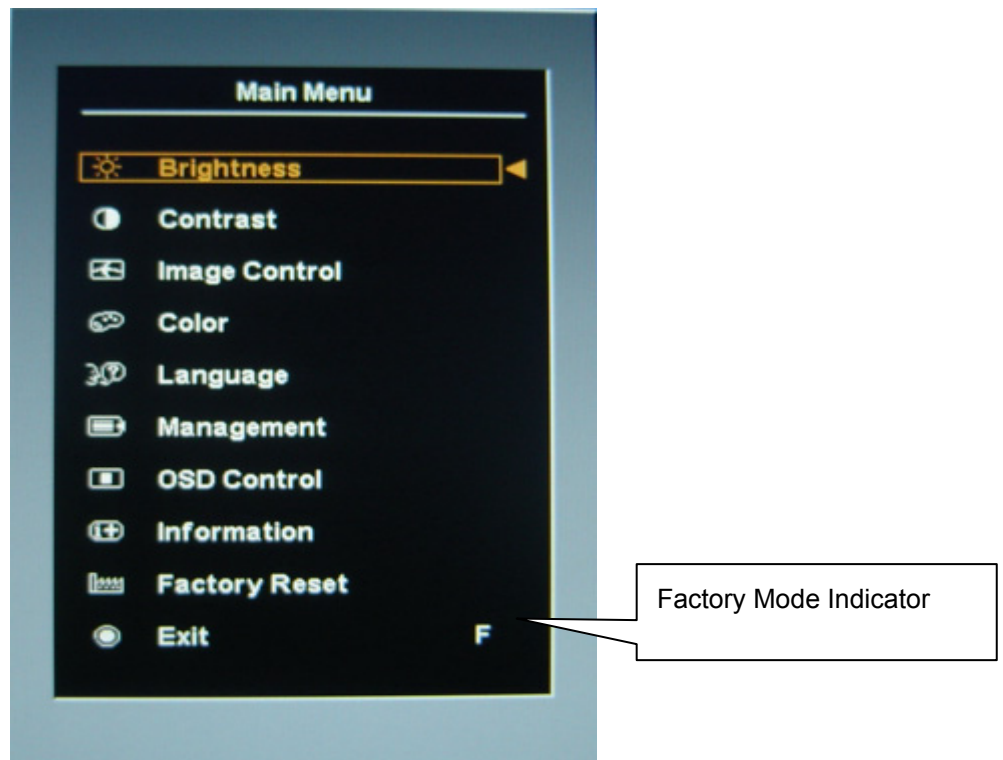























Factory Mode

1. Turn off the monitor. then press AUTO button and MENU button and hold them at the same time, then press power on, then press "Menu" button, wait until the OSD menu with Characters "F" come on the Screen of the monitor as bellow:
2. Push "Menu" to exit OSD menu.



Menu icons

No.	Control	Icon
1	Brightness	
2	Contrast	
3	Auto Adjustment	
4	Image Control	
5	Color	
6	Custom Color	
7	Language	
8	Management	
9	OSD Control	
10	Information	
11	Factory Reset	
12	Default Video Input	
13	Horizontal Position	
14	Vertical Position	
15	Clock	
16	Clock Phase	
17	Power Saver	
18	Mode Display	
19	Power-On Status Display	
20	Sleep Timer	
21	Basic Menu	
22	Advanced Menu	
23	Power On Recall	
24	Horizontal OSD Position	
25	Vertical OSD Position	
26	OSD Timeout	
27	OSD Transparency	
28	Exit	

4. Input/Output Specification

4.1 Input Signal Connector

Analog Connector Pin layout					
Pin	Mnemonic	Signal	Pin	Mnemonic	Signal
1	RV	Red Video	9	+5 V	+5 V (from PC)
2	GV	Green Video	10	SG	Sync Ground
3	BV	Blue Video	11	NC	None
4	NC	None	12	SDA	DDC Data
5	GND	GND / Cable Detect	13	HS	Horizontal Sync
6	RG	Red GND	14	VS	Vertical Sync
7	GG	Green GND	15	SCL	DDC Clock
8	BG	Blue GND			

VGA connector layout

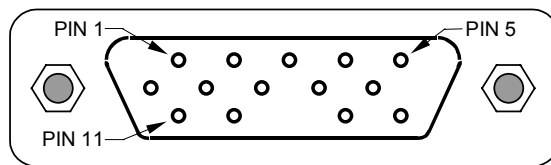

DVI-D Digital Connector Pins					
Pin.	Mnemonic	Signal	Pin.	Mnemonic	Signal
1	TX 2 -	TMDS Negative differential input, channel 2	13	TX 3 +	TMDS Data 3 +
2	TX 2 +	TMDS Positive differential input, channel 2	14	+5V	+5V Power
3	SHLD 2 / 4	Shield for TMDS channels 2 / 4	15	GND	GND / Cable Detect
4	TX 4 -	TMDS Data 4 -	16	HPD	Hot Plug Detect
5	TX 4 +	TMDS Data 4 +	17	TX 0 -	TMDS Data 0 -
6	DDC Clk	DDC Clock	18	TX 0 +	TMDS Data 0 +
7	DDC Data	DDC Data	19	SHLD 0 / 5	TMDS Data 0 / 5 Shield
8	AVS	Analog Vertical Sync	20	TX 5 -	TMDS Data 5 -
9	TX 1 -	TMDS Data 1 -	21	TX 5 +	TMDS Data 5 +
10	TX 1 +	TMDS Data 1 +	22	TX CLK SHLD	TMDS Clock Shield
11	SHLD 1 / 3	TMDS Data 1 / 3 Shield	23	TX CLK +	TMDS Clock +
12	TX 3 -	TMDS Data 3 -	24	TX CLK -	TMDS Clock -

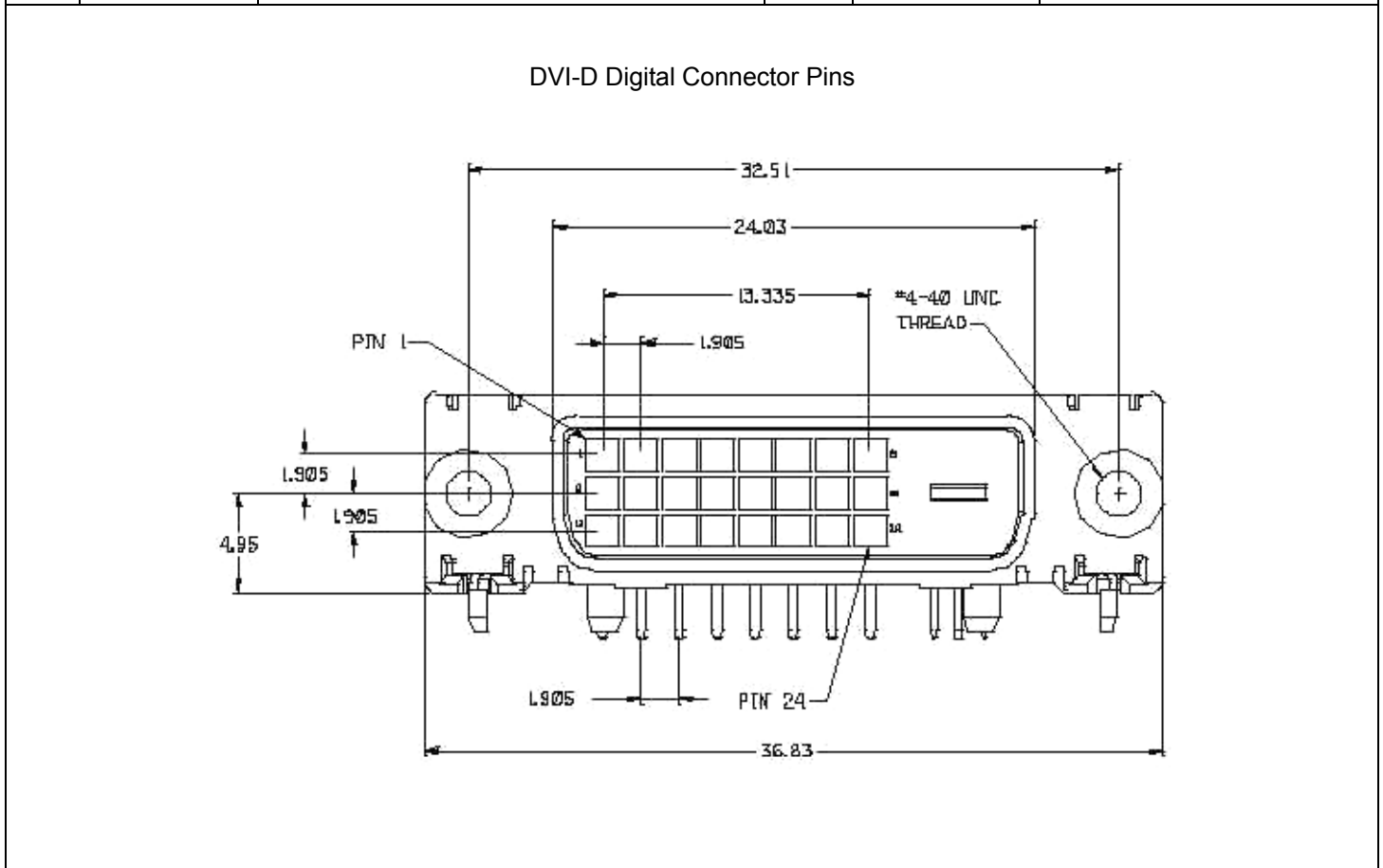

4.2 Factory Preset Display Modes

Preset	Pixel Format	Horz Freq (KHz)	Horz Polarity	Vert Freq (Hz)	Vert Polarity	Pixel Clk (MHz)	Source
1	640 x 480	31.469	-	59.940	-	25.175	VGA
2	640 x 480	37.861	-	72.809	-	31.500	VESA
3	640 x 480	37.500	-	75.000	-	31.500	VESA
4	720 x 400	31.469	-	70.087	+	28.322	VGA
5	800 x 600	37.879	+	60.317	+	40.000	VESA
6	800 x 600	48.077	+	72.188	+	50.000	VESA
7	800 x 600	46.875	+	75.000	+	49.500	VESA
8	832 x 624	49.726	±	74.551	±	57.284	MAC
9	1024 x 768	48.363	-	60.004	-	65.000	VESA
10	1024 x 768	56.476	-	70.069	-	75.000	VESA
11	1024 x 768	60.023	+	75.029	+	78.750	VESA
12	1152 x 870	68.68	-	75.06	-	100.000	Mac
13	1152 x 900	71.71	-	76.05	-	105.561	Sun
14	1280 x 1024	63.98	+	60.02	+	108.000	VESA
15	1280 x 1024	79.97	+	75.02	+	135.000	VESA

4.3 Power Supply Requirements

PARAMETER	RANGE
AC Input Voltage	90 to 265V
AC Input Frequency	47 to 63 Hz
Inrush Current	50A MAX AT 220VAC and 30A AT 120VAC
Leakage Current	5 mA MAX at 120VAC
Power consumption	≤70W

5. Panel Specification

5.1 General Feature

- Wide viewing angle.
- High contrast ratio
- Super fast response time
- High color saturation
- SXGA (1280 x 1024 pixels) resolution
- DE (Data Enable) only mode
- LVDS (Low Voltage Differential Signaling) interface
- RoHS Compliance

Item	Specification	Unit
Active Area	376.32 (H) x 301.056 (V) (19.0" diagonal)	mm
Bezel Opening Area	380.2(H) x 305(V)	mm
Driver Element	a-si TFT active matrix	-
Pixel Number	1280 x R.G.B. x 1024	pixel
Pixel Pitch	0.294 (H) x 0.294 (V)	mm
Pixel Arrangement	RGB vertical stripe	-
Display Colors	16.2M	color
Transmissive Mode	Normally White	-
Surface Treatment	Hard coating (3H), Anti-glare (Haze 25)	-

5.2 Optical Characteristics

Test Conditions

Item	Symbol	Value	Unit
Ambient Temperature	Ta	25±2	°C
Ambient Humidity	Ha	50±10	%RH
Supply Voltage	V _{CC}	5.0	V
Input Signal	According to typical value in "3. ELECTRICAL CHARACTERISTICS"		
Lamp Current	I _L	7	mA
Inverter Operating Frequency	F _L	61	KHz
Inverter	SUMIDA H05 5307		

Optical Specifications

Item		Symbol	Condition	Min.	Typ.	Max.	Unit
Color Chromaticity	Red	R _x	$\theta_x=0^\circ, \theta_y=0^\circ$ CS-1000T	Typ – 0.03	0.645	Typ + 0.03	
		R _y			0.332		
	Green	G _x			0.285		
		G _y			0.600		
	Blue	B _x			0.151		
		B _y			0.074		
	White	W _x			0.313		
		W _y			0.329		
Center Luminance of White		L _C		230	300	---	cd/m ²
Contrast Ratio		CR		450	700	---	-
Response Time		T _R	$\theta_x=0^\circ, \theta_y=0^\circ$	---	2	4	ms
		T _F			6	12	
White Variation		δW	$\theta_x=0^\circ, \theta_y=0^\circ$	---	1.25	1.40	-
Cross Talk		CT	BM-5A	---	---	5.0	%
Viewing Angle	Horizontal	θ _{x+}	CR • •10 BM-5A		65	75	Deg.
		θ _{x-}			65	75	
	Vertical	θ _{y+}			60	70	
		θ _{y-}			50	60	

6. Monitor Exploded View

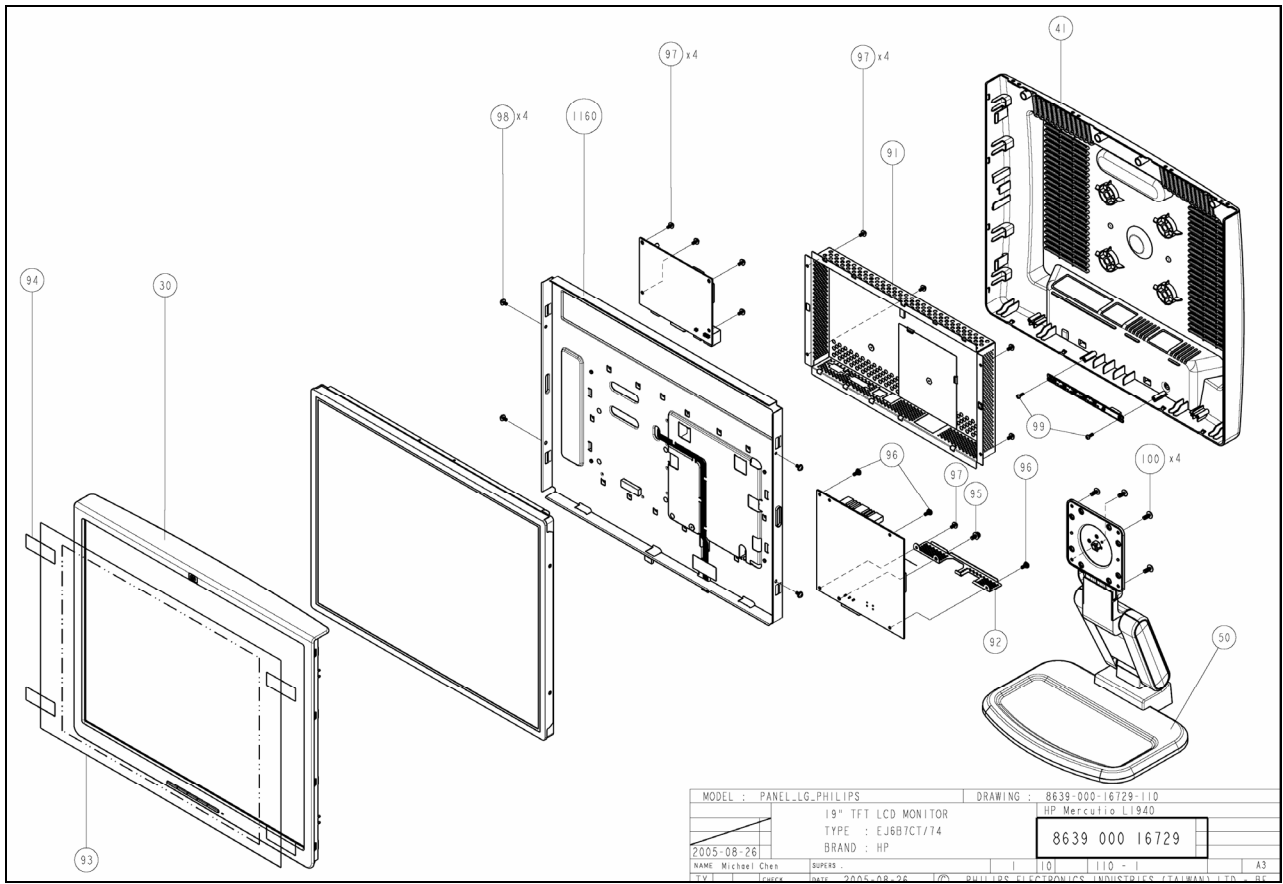

7. Block Diagram

7.1 Scalar Board

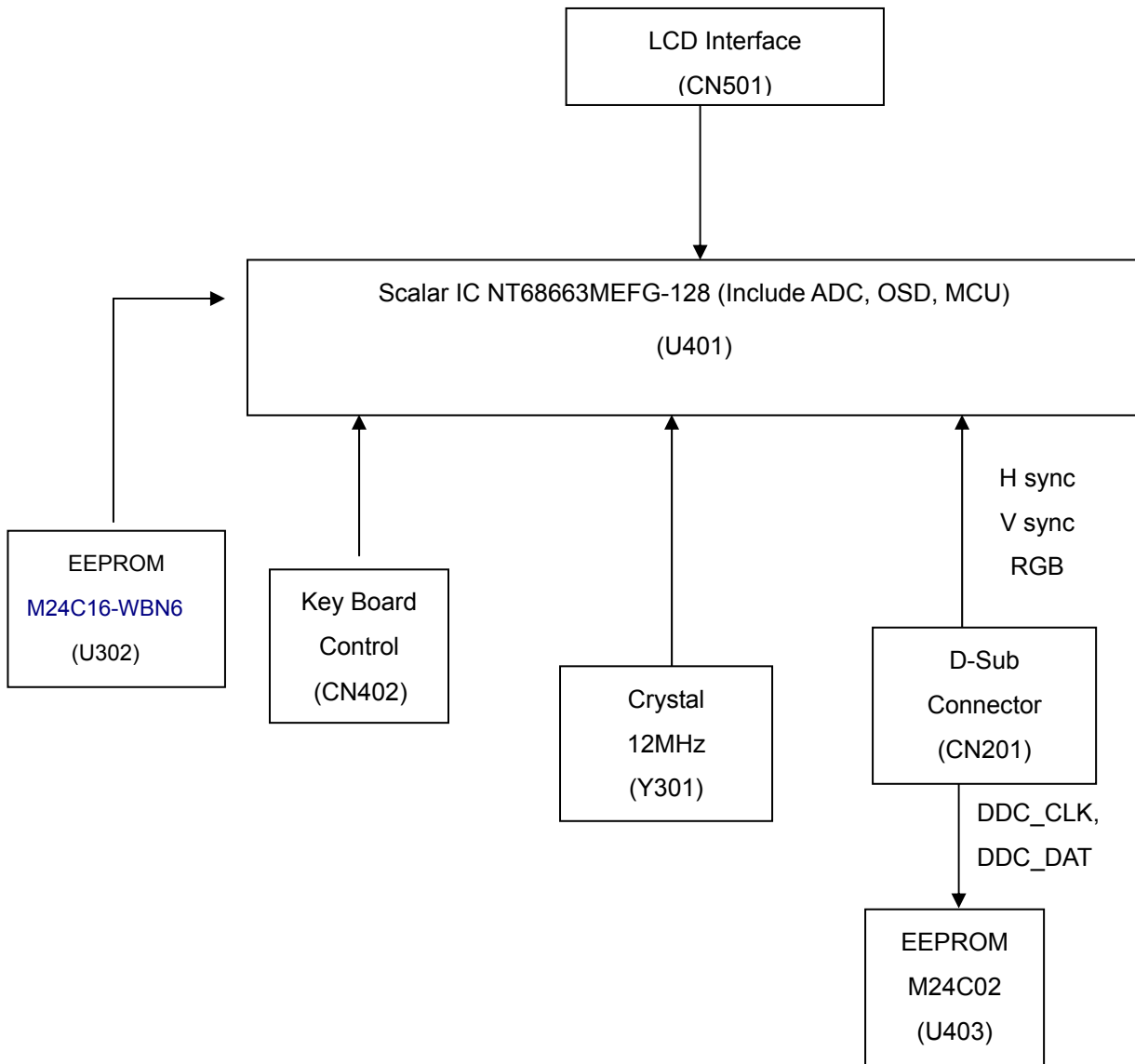

7.2 Inverter / Power Board

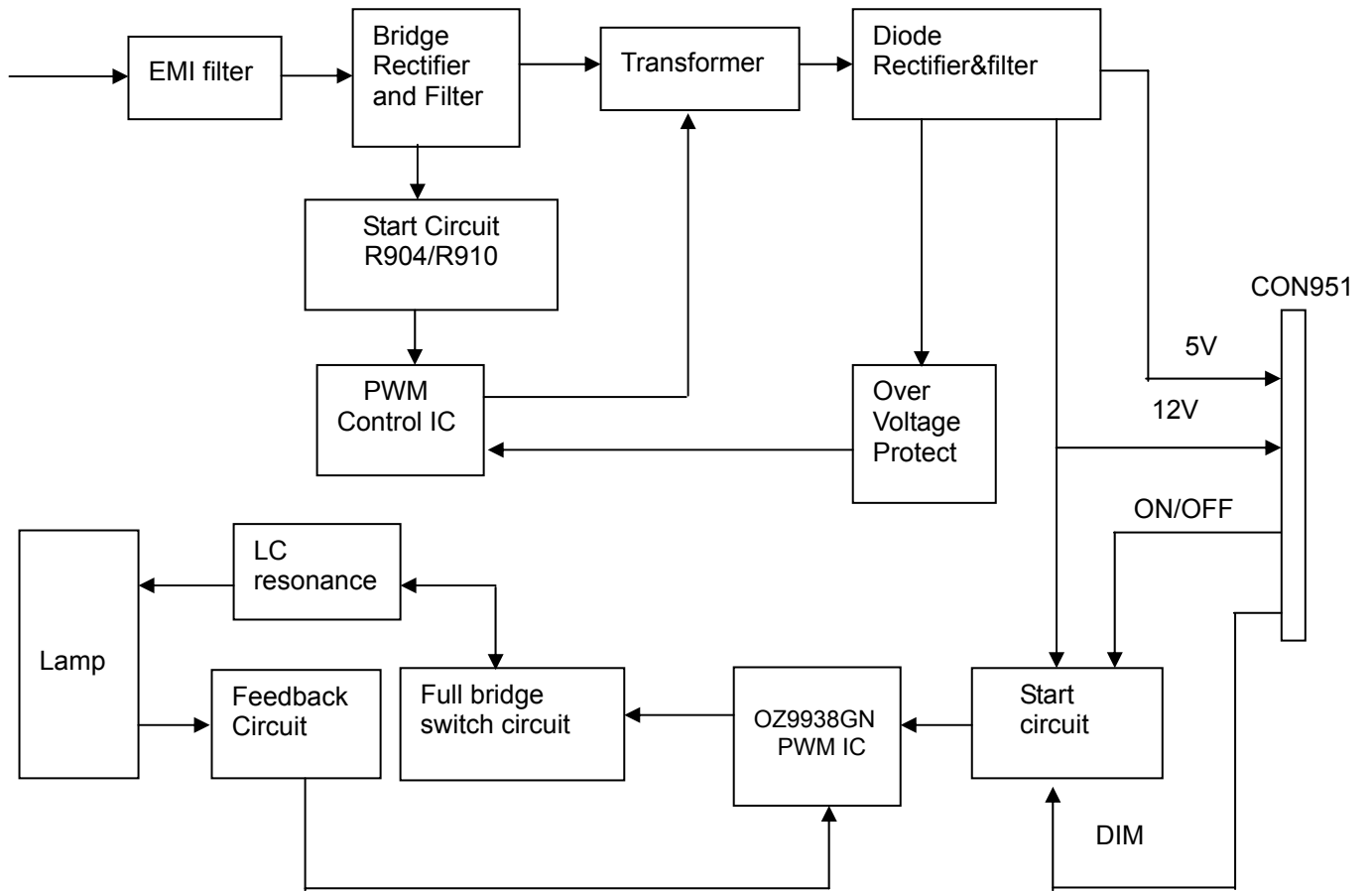

8. Maintainability

Equipments and Tools Requirement

- 1 · Multi-meter.
- 2 · Oscilloscope.
- 3 · Pattern Generator.
- 4 · DDC Tool with an IBM Compatible Computer.
- 5 · Alignment Tool.
- 6 · LCD Color Analyzer.
- 7 · Service Manual.
- 8 · User Manual.

8.1 Main Board

1. No power

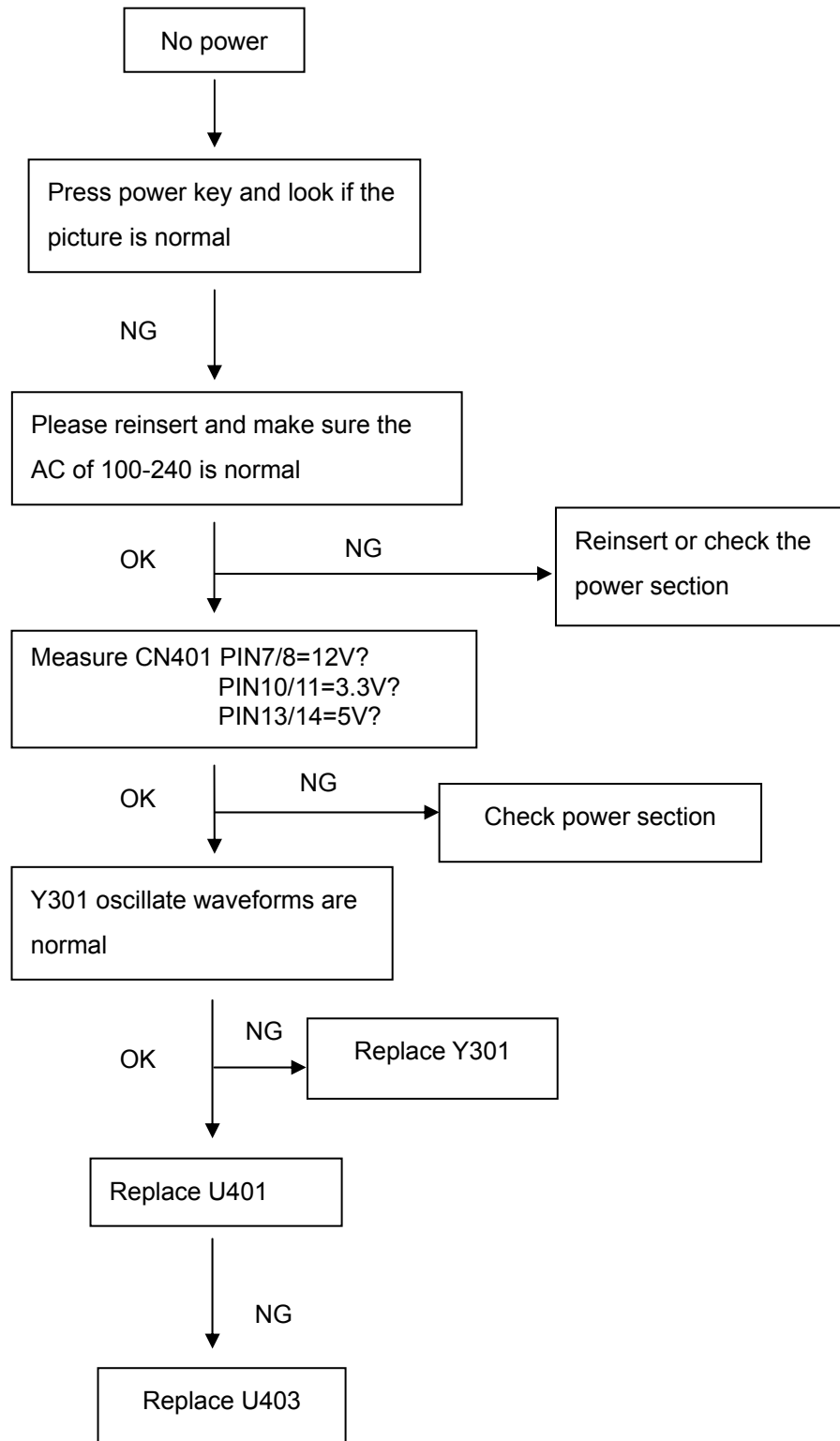

No picture (LED is orange)

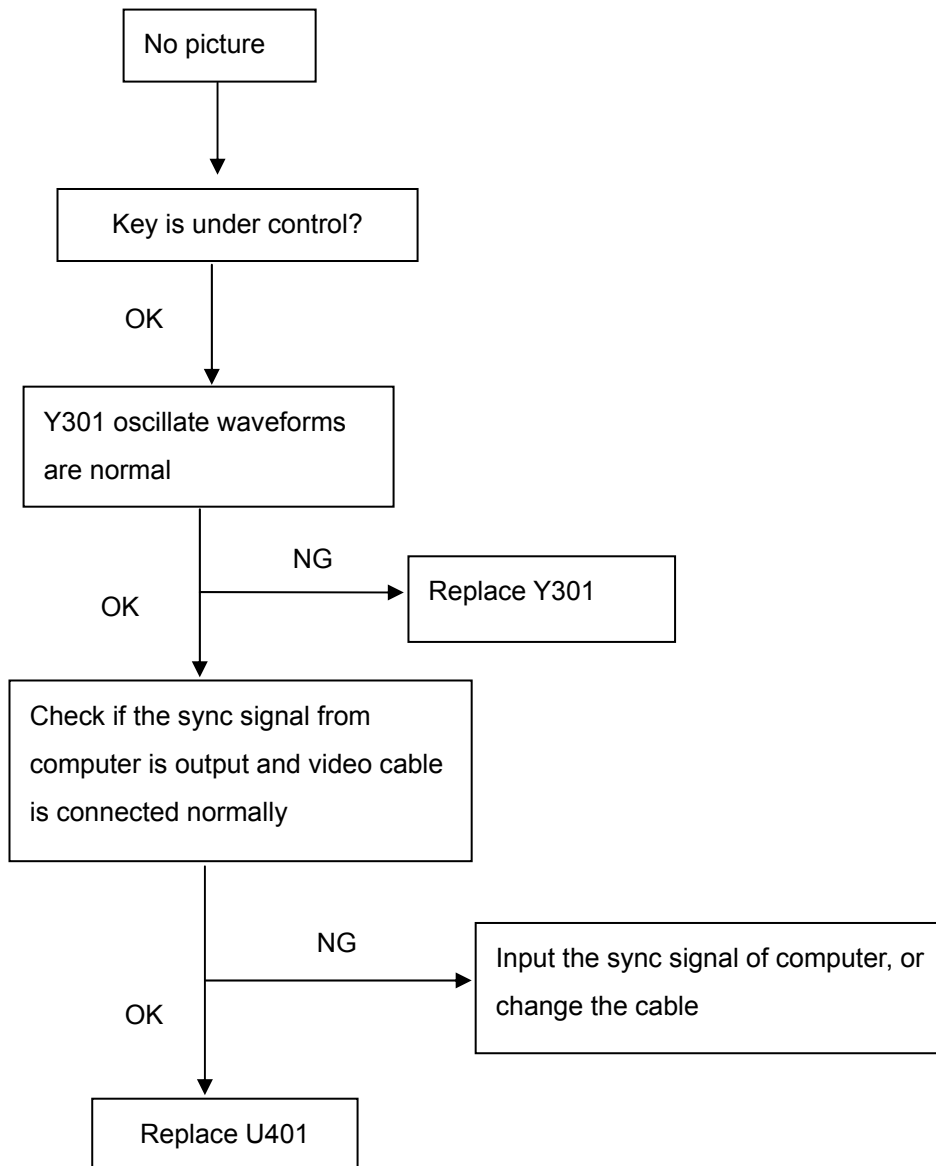

Panel Power Circuit

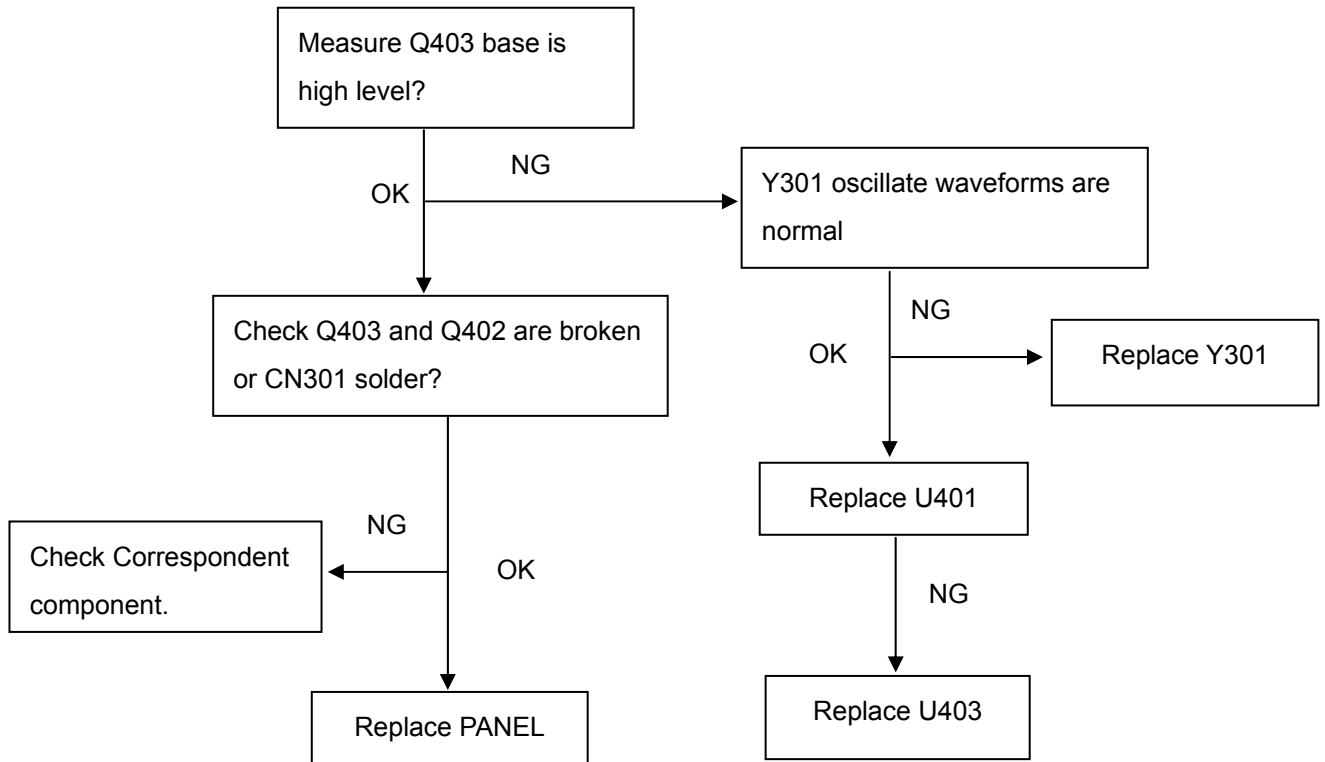

8.2 Power Board

1. No Power

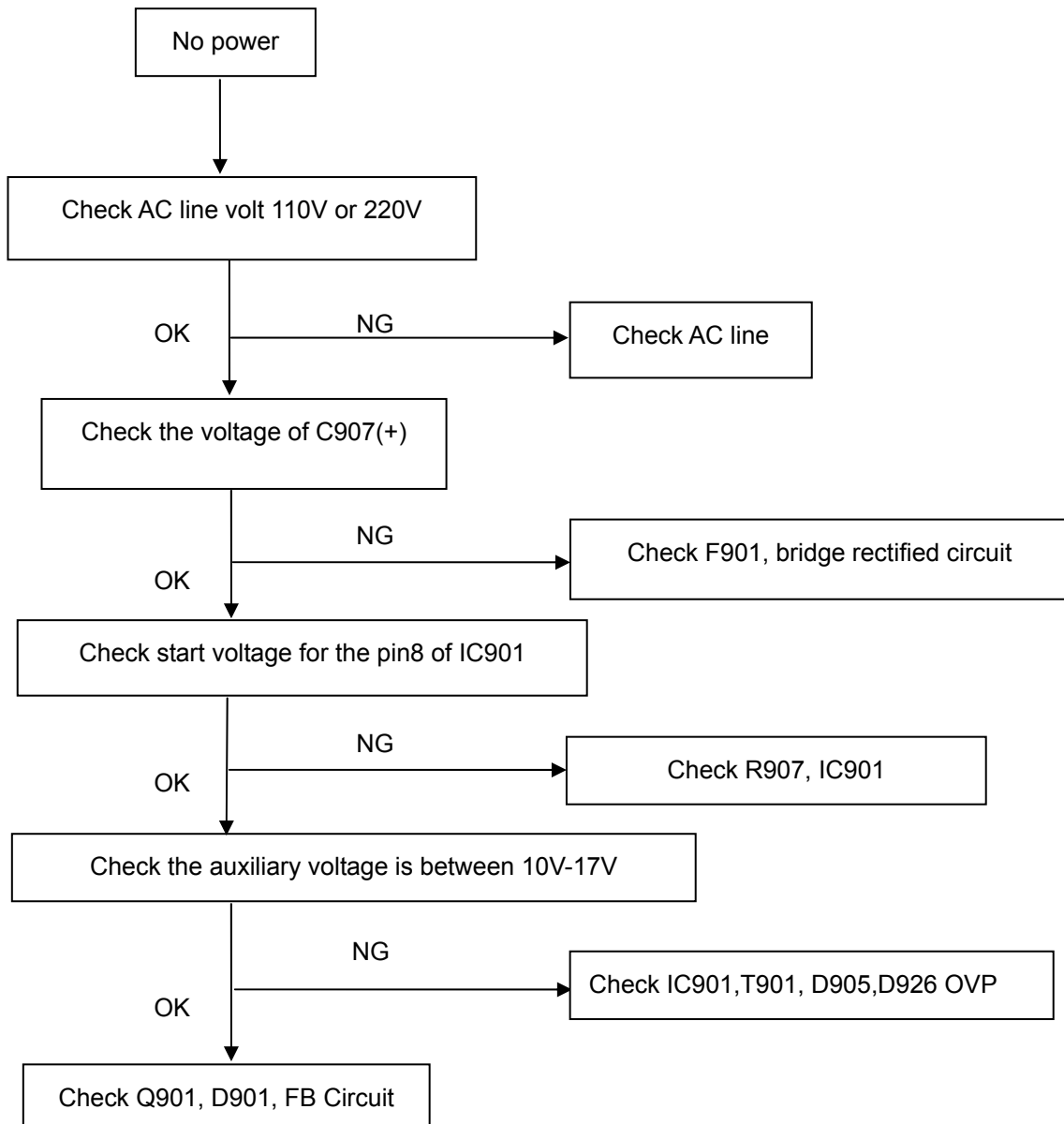

2. W/LED No Backlight

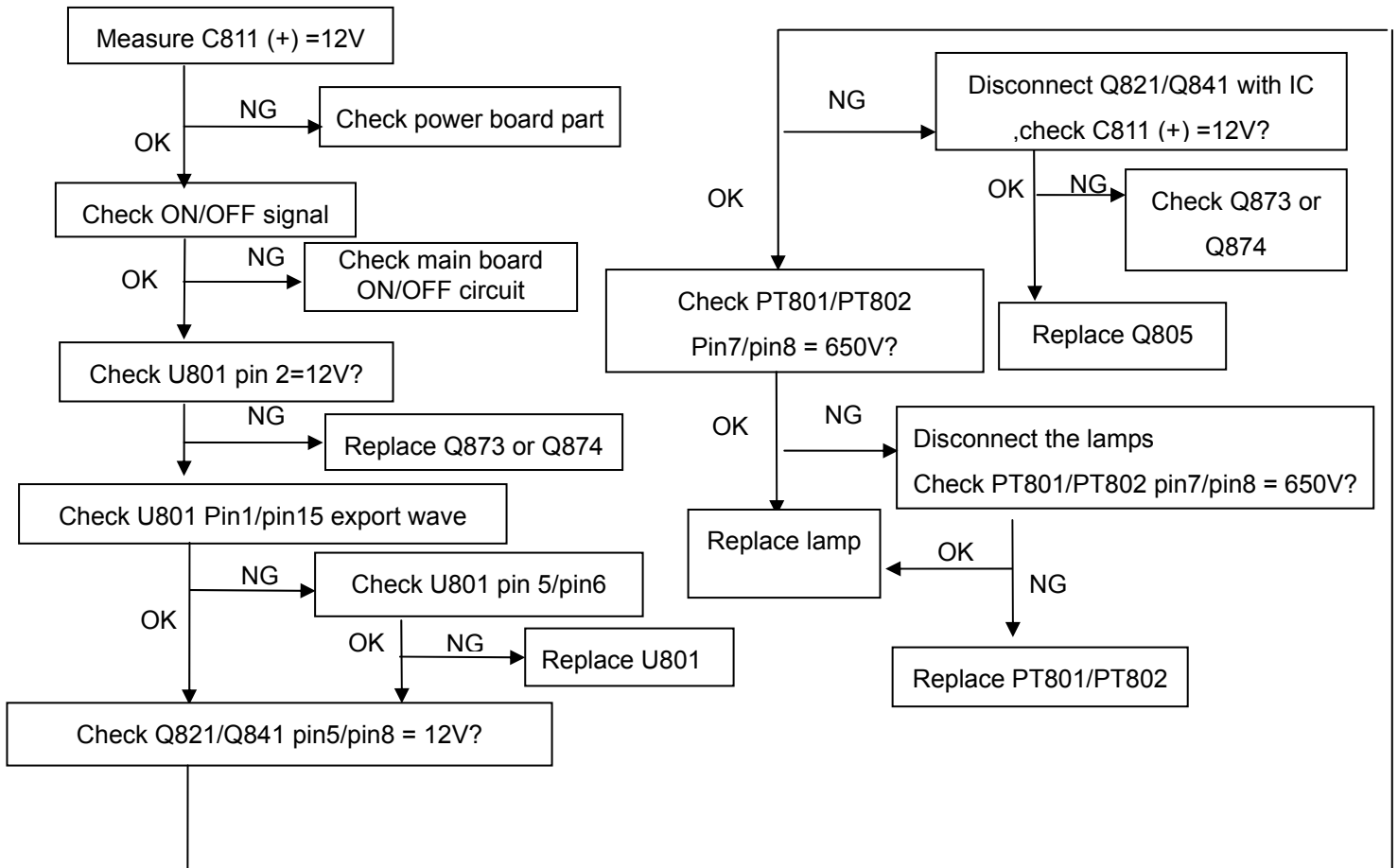

3. Protected 1

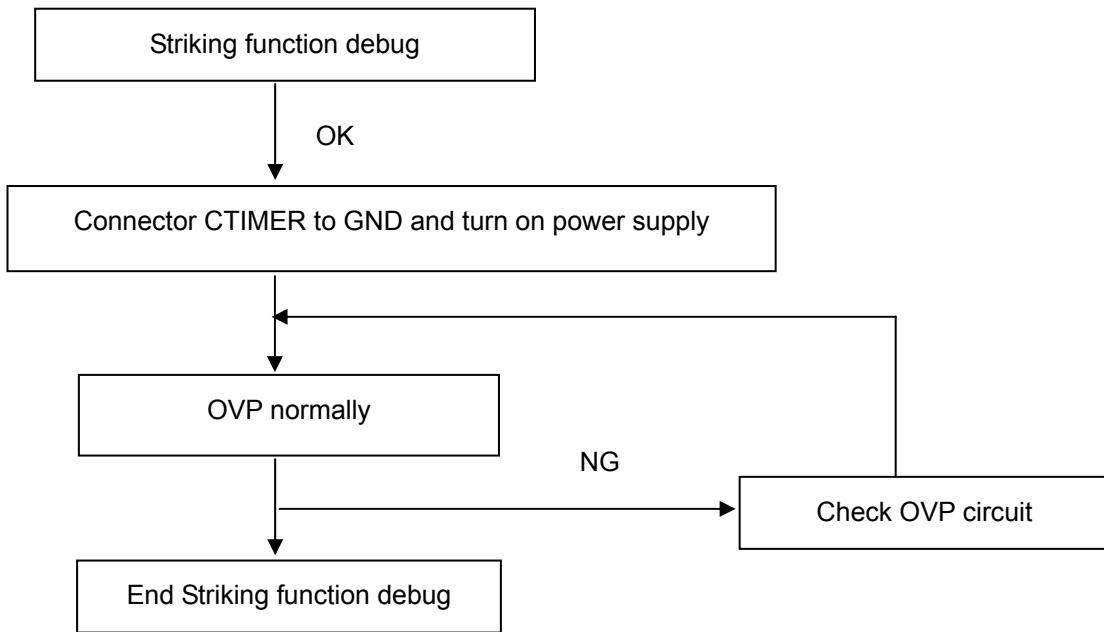

4. Protected 2

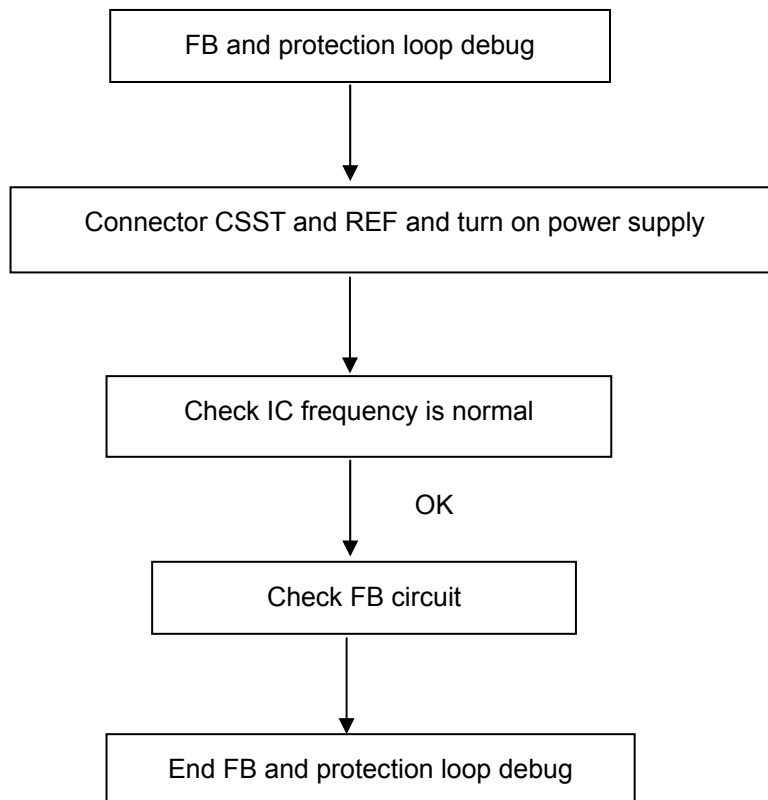

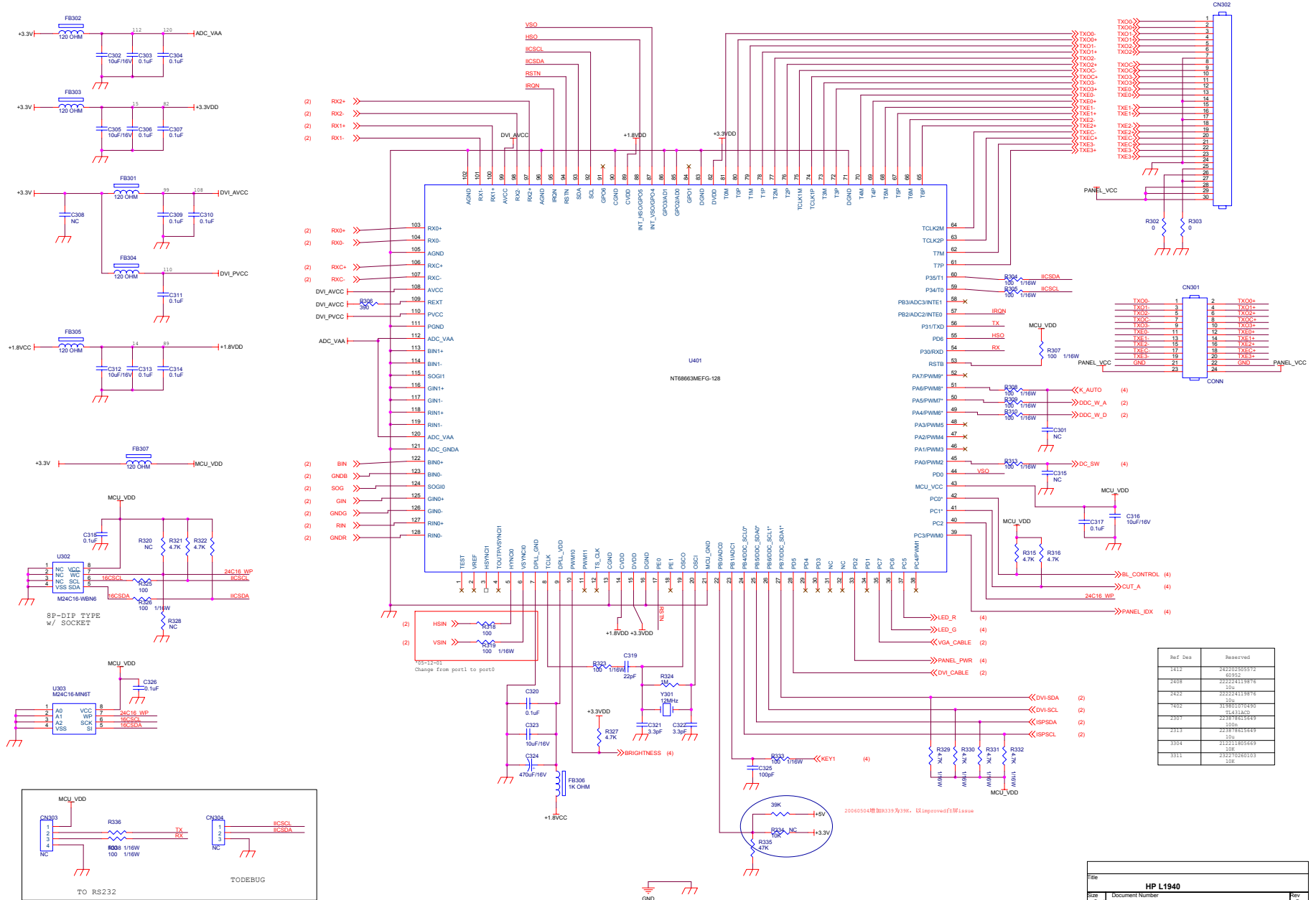

Ref. Des.	Reserved
1412	24220555572 6952
2408	22224119176 100
2422	22224119176 100
7402	31390107490 1643460
2307	22187861649 100
2311	22187861649 100
3304	2122185668 100
3311	2322026103 100

Title	HP L1940	
Doc. Number	NT8663 (MCU+SCALER A)	
Date	Friday, May 05, 2006	Sheet 3 of 5

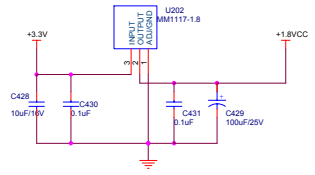
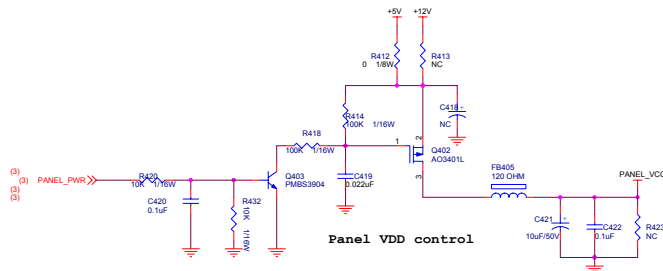
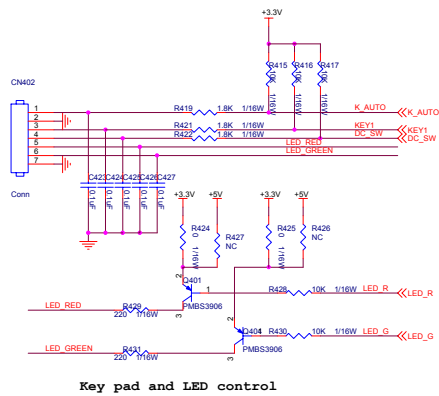
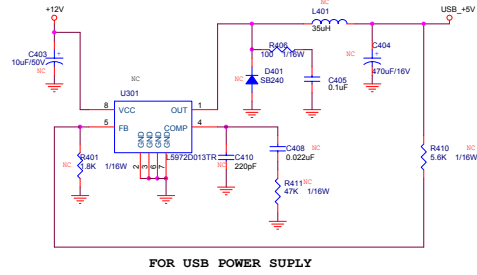
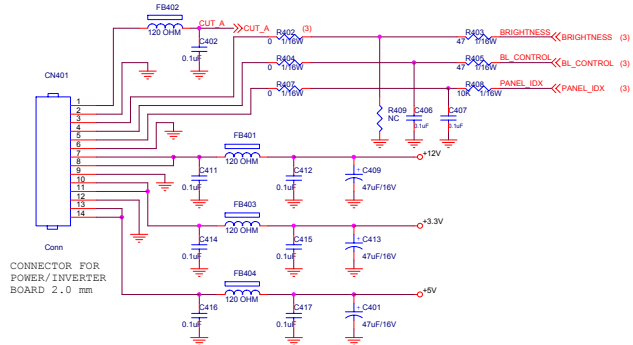

File	715Gxxxx	
Size	Document Number	Rev
C	Power and control board	B
Date:	Friday, Mar 05, 2009	Sheet 4 of 5

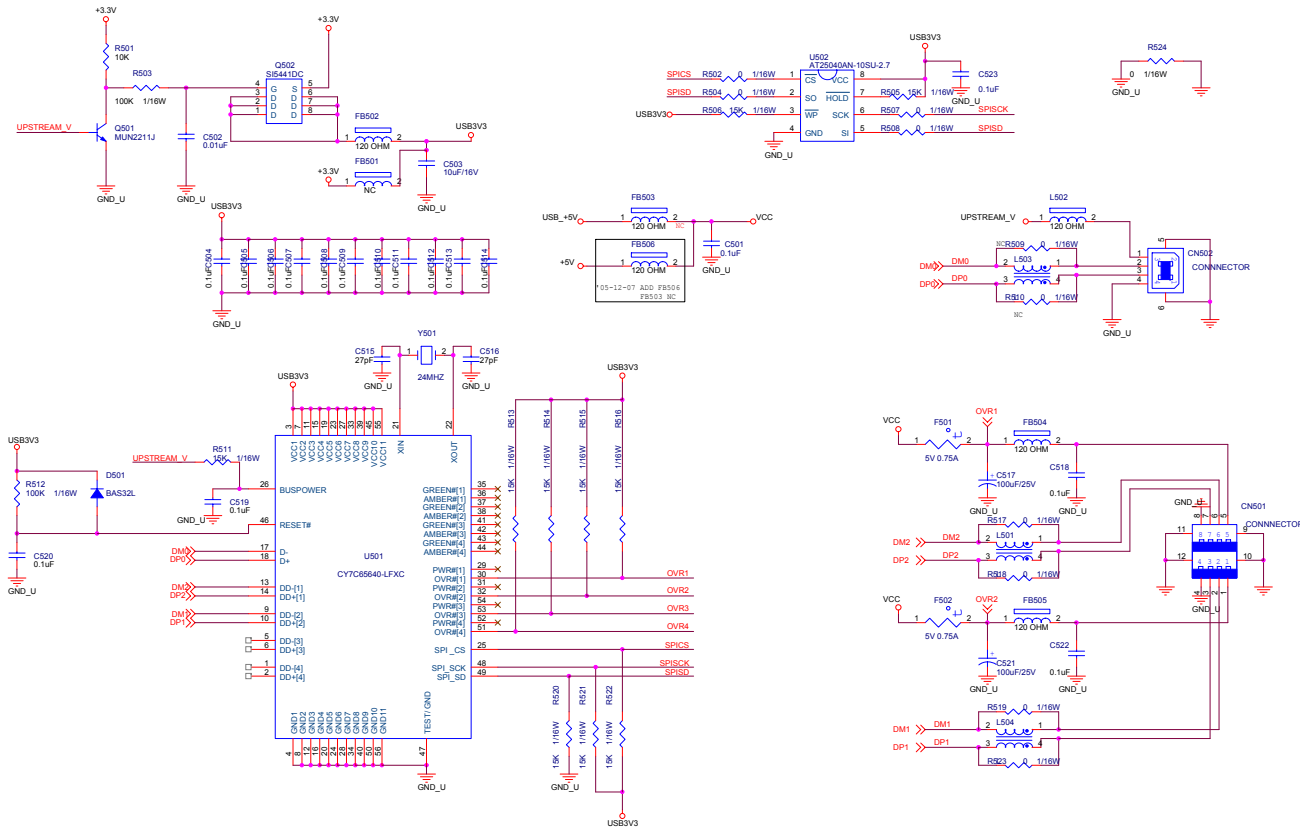

Title		
<Title>USB HUB 200WP?		
Size	Document Number	Rev
C		B
Date:	Friday, May 05, 2006	Sheet 5 of 5

9.2 Power Board (include inverter and power)

Inverter Schematic

Philips HPL1940T/L1740

PCB : 715G1821-1/715G1995-1

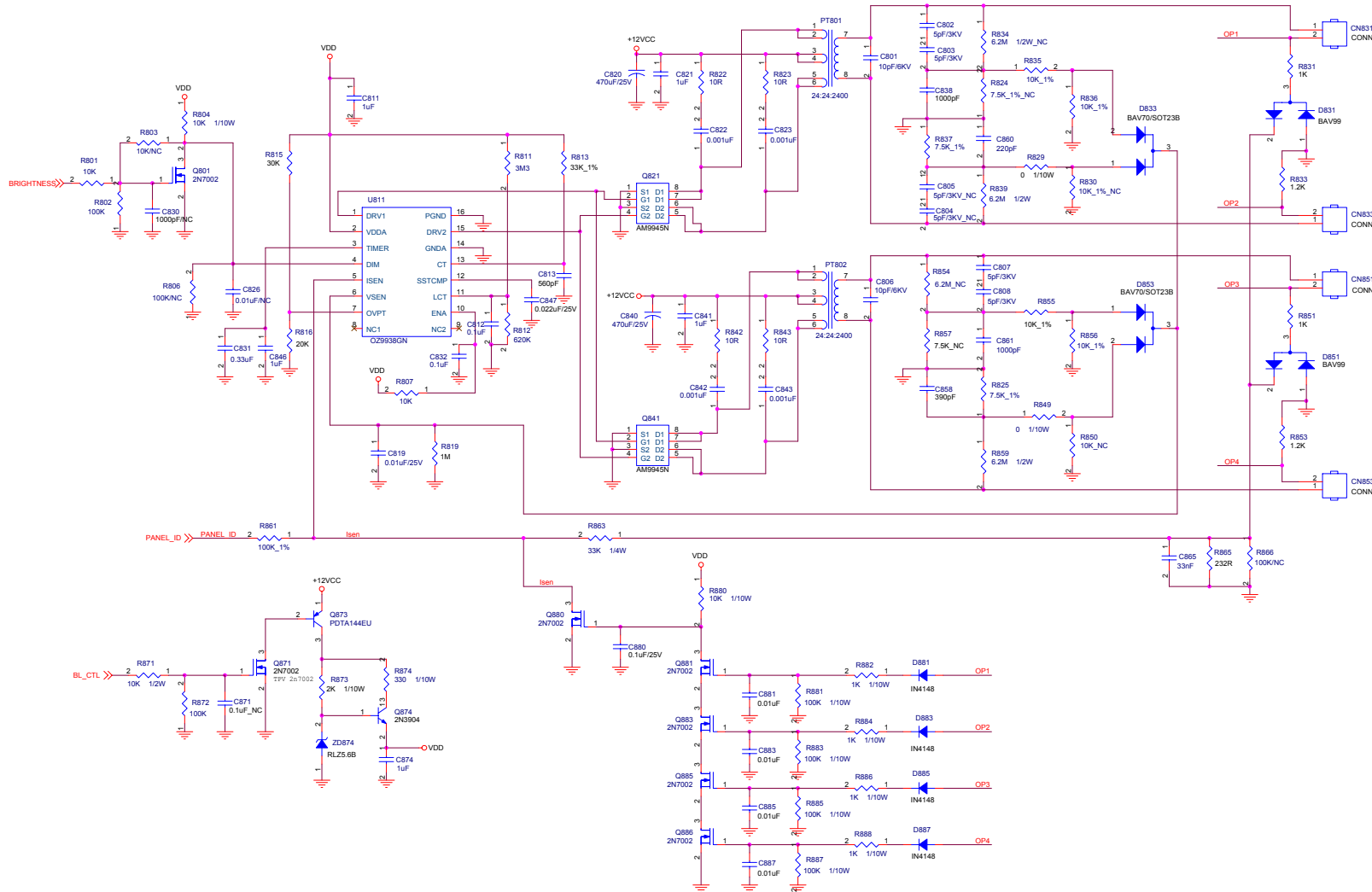

Adapter Schematic

Philips HPL1940/L1740
PCB : 715G1821-1/715G1995-1

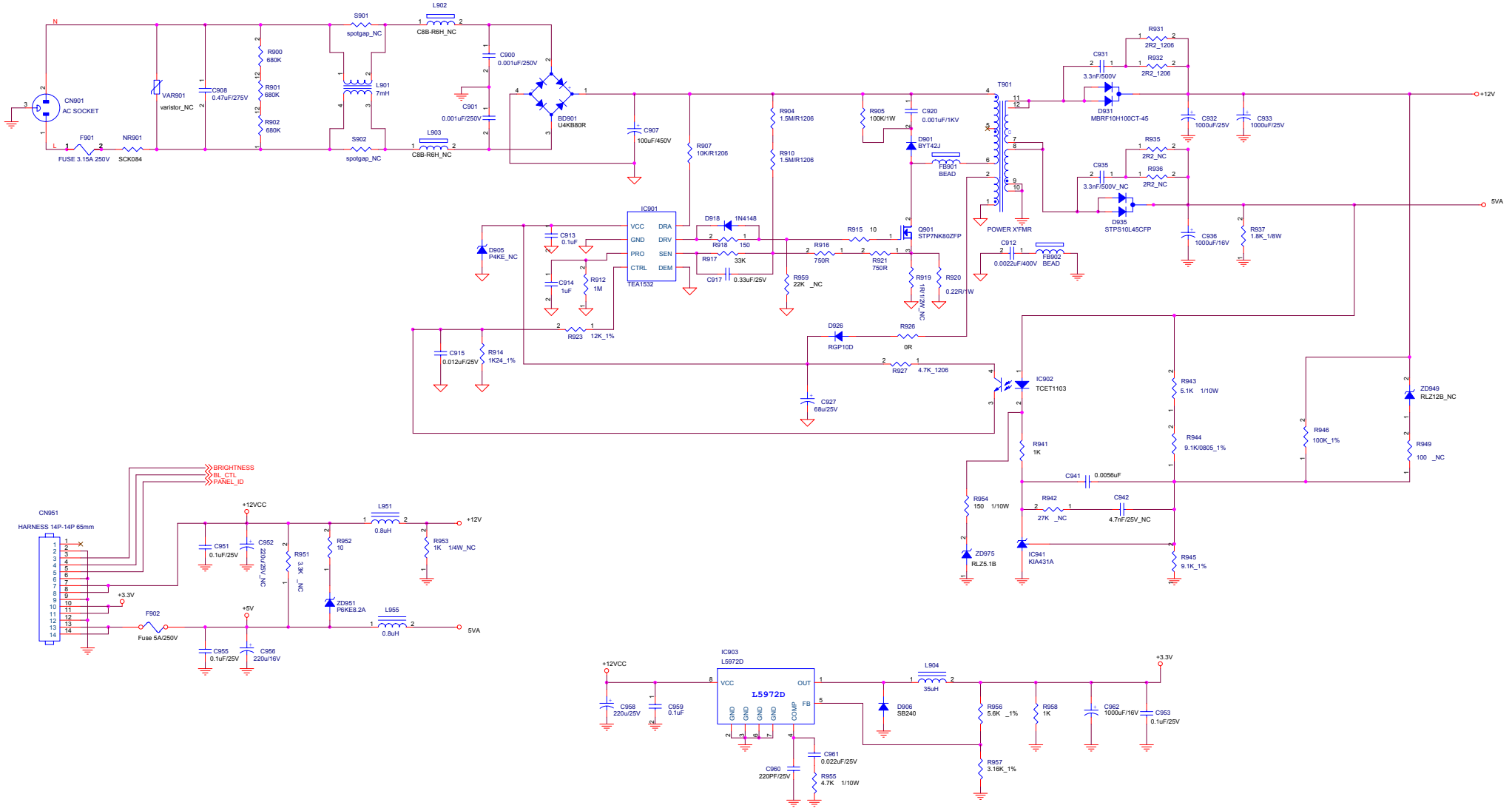

11. White-Balance, Luminance Adjustment

Approximately 30 minutes should be allowed for warm up before proceeding White-Balance adjustment.

1. How to do the Chroma-7120 MEM .Channel setting

- A. Reference to chroma 7120 user guide
- B. Use “**SC**” key and “**NEXT**” key to modify xyY value and use “**ID**” key to modify the TEXT description Following is the procedure to do white-balance adjust

2. Setting the color temp. You want

A. 9300 color:

9300 color temp. parameter is $x = 283 \pm 20$, $y = 297 \pm 20$, $Y = 180 \text{ cd/m}^2$.

B. 6500K color:

6500K color temp. parameter is $x = 313 \pm 20$, $y = 329 \pm 20$, $Y = 180 \text{ cd/m}^2$

C. sRGB color:

sRGB color temp. parameter is $x = 313 \pm 20$, $y = 329 \pm 20$, $Y = 150 \text{ cd/m}^2$

3. Into factory mode of HP L1940T

Turn off the monitor. then press AUTO button and MENU button and hold them at the same time, then press power on, then press Menu button, wait until the OSD menu with Characters “F” come on the Screen of the monitor.

4. Bias adjustment:

Set the **Contrast**  to 80

Adjust the **Brightness**  to 90.

5. Gain adjustment :

Move cursor to “-F-” and press MENU key

A. Adjust 9300k color-temperature

1. Switch the Chroma-7120 to **9300k channel**.
2. The chroma 7120 will show $x = 283 \pm 20$, $y = 297 \pm 20$, $Y = 180 \text{ cd/m}^2$
3. Switch the chroma-720 to **RGB MODE** (with press “MODE” button to change)
4. Adjust the RED of color **9300K** on factory window until chroma 7120 indicator reached the value $R=100$
5. Adjust the GREEN of color **9300K** on factory window until chroma 7120 indicator reached the value $G=100$
6. Adjust the BLUE of color **9300K** on factory window until chroma 7120 indicator reached the value $B=100$
7. Repeat above procedure (item 4,5,6) until chroma 7120 RGB value meet the tolerance $=100 \pm 2$

B. Adjust 6500K color-temperature

1. Switch the chroma-7120 to **6500K channel**.

2. The chroma 7120 will show $x = 313 \pm 20$, $y = 329 \pm 20$, $Y = 180 \text{ cd/m}^2$
 3. Switch the chroma 7120 I to **RGB MODE** (with press "MODE" button to change)
 4. Adjust the RED of color **6500K** on factory window until chroma 7120 indicator reached the value $R=100$
 5. Adjust the GREEN of color **6500K** on factory window until chroma 7120 indicator reached the value $G=100$
 6. Adjust the BLUE of color **6500K** on factory window until chroma 7120 indicator reached the value $B=100$
 7. Repeat above procedure (item 4,5,6) until chroma 7120 RGB value meet the tolerance $=100 \pm 2$
- C. Adjust sRGB color-temperature
1. Switch the chroma-7120 to **sRGB channel**.
 2. The chroma 7120 will show $x = 313 \pm 20$, $y = 329 \pm 20$, $Y = 150 \text{ cd/m}^2$
 3. Switch the chroma 7120 I to **RGB MODE** (with press "MODE" button to change)
 4. Adjust the RED of color **sRGB** on factory window until chroma 7120 indicator reached the value $R=100$
 5. Adjust the GREEN of color **sRGB** on factory window until chroma 7120 indicator reached the value $G=100$
 6. Adjust the BLUE of color **sRGB** on factory window until chroma 7120 indicator reached the value $B=100$
 7. Repeat above procedure (item 4,5,6) until chroma 7120 RGB value meet the tolerance $=100 \pm 2$
- D. Press reset key and Turn the Power-button "off to on" to quit from factory mode.

12. EDID Content**Analog**

	00	01	02	03	04	05	06	07	08	09	10	11	12	13	14	15
0:	00	FF	FF	FF	FF	FF	FF	00	22	F0	2E	26	01	01	01	01
16:	36	10	01	03	68	26	1E	78	EE	EE	95	A3	54	4C	99	26
32:	0F	50	54	AD	EF	80	81	80	01	01	01	01	01	01	01	01
48:	01	01	01	01	01	01	30	2A	00	98	51	00	2A	40	30	70
64:	13	00	52	0E	11	00	00	1E	00	00	00	FF	00	32	31	33
80:	36	35	34	39	38	37	35	0A	20	20	00	00	00	FD	00	38
96:	4C	1E	53	0E	00	0A	20	20	20	20	20	20	00	00	00	FC
112:	00	48	50	20	4C	31	39	34	30	54	0A	20	20	20	00	3D

Digital

	00	01	02	03	04	05	06	07	08	09	10	11	12	13	14	15
0:	00	FF	FF	FF	FF	FF	FF	00	22	F0	2F	26	01	01	01	01
16:	02	0E	01	03	80	26	1E	78	EE	EE	95	A3	54	4C	99	26
32:	0F	50	54	AD	EF	80	81	80	01	01	01	01	01	01	01	01
48:	01	01	01	01	01	01	30	2A	00	98	51	00	2A	40	30	70
64:	13	00	52	0E	11	00	00	1E	00	00	00	FF	00	43	4E	43
80:	34	30	32	31	32	33	34	0A	20	20	00	00	00	FD	00	38
96:	4C	1E	53	0E	00	0A	20	20	20	20	20	20	00	00	00	FC
112:	00	48	50	20	4C	31	39	34	30	54	0A	20	20	20	00	38

13. BOM List**T981KMNDKHPQP**

Location	Part No.	Description	Remark
	034G6402 EY B	REAR COVER	
	037G6057 2	HINGE	
	040G 58169016A	TCO'03 LABEL	
	041G7800690A16	QSG FOR EUR	
	041G7800690B01	SCREEN RESOLUTION	
	044G3231 15571	EVA WASHER	
451	044G3957 1	CUSHION-R	
452	044G3957 2	CUSHION-L	
	050G 600 1 W	WHITE STRAP	
	052G 1150 C	INSULATING TAPE	
	052G 1185	MIDDLE TAPE	
	052G 1186	SMALL TAPE	
	052G6019 1	INSULATING TAPE	
94	052G6022 1500	SMALL TAPE	
341	052G6025 11975	INSULATION PLATE	
E80	080G L19502 FC	PSU OPENFR IPS 35W(T50P057.02)	
340	085G6157 1	MAIN SHIELD	
1159	089G 175507	USB CABLE	
E095B	089G 718RAADP1	CORD SUB-D 15/1M8/15 D-SUB BK	2nd source
E095B	089G 718WAADP1	CORD SUB-D 15/1M8/SUB-D 15BK	
	089G179J 30713	FFC 30PIN P1.0	
E089A	089G404A19N IS	POWER CORD	2nd source
E089A	089G404A19N LS	POWER CORD	
	0M1G 130 4225 CR3	SCREW	
100	0M1G1340 10 47 CR3	SCREW	
	0M1G1430 5120	SCREW	
97	0M1G1430 5120	SCREW	
95	0M1G1640 8120	SCREW PHM4-0.7X8	
	0M1G1730 6120	SCREW,42-D020523	
99	0Q1G 130 8120	SCREW 42A9930011	
	0Q1G 330 8120	SCREW 3X8mm 42A9930017/ 42-D002093	
96	0Q1G1130 6120	SCREW	
	705G980KF34007	BEZEL ASS'Y	
	033G6429 PM L	CONTROL BUTTON	
	033G6430 1 C	LENS-POWER	

	034G6401AFH B 30	BEZEL	
	705G980KM34004	MAIN FRAME ASS'Y	
	015G6343 1	MAIN FRAME-LPL	
	052G6025 11976	INSULATION PLATE	
	052G6025 11981	MYLAR	
	095G8P14 7505	CBLE-267 7/330/7-267 AWG28	
	Q85G 583611	GASKET_ALUMINIUM FOIL	
E750L	750GLM90E5A11Z	PANEL LCD 19" E5-L05 C1 D CMO	
	CBPC980KMHPP	CONVERSION BOARD	
	040G 45762412B	CBPC LABEL	
1503	033G3802 7	WAFER EH 7	
1502	033G3802 14	14P/2.0MM	
7302	056G11332PHMP1	IC M24C16-WBN6 (ST00)L	
7608	056G1133521LP6	IC AT93C46-10PI-2.7 ATMEL	
2624	067G 305101 4P	ELCAP KM 25V S 100U PM20 B	
2622	067G 305101 4P	ELCAP KM 25V S 100U PM20 B	
2624	067G 305101 4X	ELCAP RGA 25V S 100U PM20 B	
2622	067G 305101 4X	ELCAP RGA 25V S 100U PM20 B	
2515	067G 305470 4P	ELCAP KM 25V S 47U PM20 B	
2515	067G 305470 4X	ELCAP RGA 25V S 47U PM20 B	
2519	067G215V471 4R	LOW E.S.R 470UF +/-20% 25V	
5504	073G 253518 LS	COI CHOKE 35UH 82M OHM DR10X8	
5411	073G 25833010T	IND FXD TSL0808 S 33U PM10 B	
5504	073L 253518 HJ	COI CHOKE 35UH 82M OHM DR10X8	
1603	088G 350 1 TN	USB CONN	
1602	088G 351 2B TN	USB CONN	2nd source
1602	088G 3512B1 CL	USB CONN BLACK	
1203	088G 35315F H	D-SUB 15PIN	
1203	088G 35315F HJ	SOC SUBD H 15P F	
1203	088G 35315F HJ	SOC SUBD H 15P F	
1201	088G 35424F J	DVI 24PIN CONN F ATTACHED SCREW	
1201	088G 35424F N	DVI 24PIN CONN F 附螺丝	2nd source
1201	088G 35424F SM	SOC DVI H 24P F 1.91DVI-D Y	
6501	093G 521ZJ26T	SB240	
6501	093G 523DI26T	SB240-13-F DO-41	
1412	033G801930L FP	CON H 30P F 1.00 SM FFC 0.3R	
7403	056G 1331PH	IC SM LD1117AS18(ST00)R	
7505	056G 158805	IC L5972D013TR S08	

7601	056G 545500	IC USB HUB GL850A 64PIN GENESYS	
7401	056G 562 70	GM5321 QFP-208	
7403	056G 563 27	IC AIC1117A-18PYTR-R SOT223	
7202	056G1133 20	AT24C02N-10SU-2.7	
7203	056G1133 20	AT24C02N-10SU-2.7	
7202	056G1133 34	M24C02-WMN6TP	
7203	056G1133 34	M24C02-WMN6TP	
7301	056G1133519MP3	IC AT49BV002ANT-70JU ATMEL	
7210	056G4LCX 14 PH	IC 74LVC14APW PHILIPS	
7210	056G4LCX 14 ST	IC SM 74LCX14T	
7210	056G4LVC 14 TI	IC SN74LVC14APWR TSSOP-14 TI	
7501	057G 420519 T	BC857C	
7502	057G 420519 T	BC857C	
7503	057G 7601PH	TRA SIG SM MUN2211J(ONSE)R	
7503	057G 7602PH	TRA PDTC114EK SC-59 PHILIPS	
7503	057G 760500KEC	TRA KRC102S KEC	
7504	057G 7631PH	FET POW SM SI5441DC(VISH)R	
3620	061G 56075 WT	SMD PTC 0.75A KMC5S075R001 1812	
3622	061G 56075 WT	SMD PTC 0.75A KMC5S075R001 1812	
3653	061G0603000	RST CHIPR 0 OHM +-5% 1/10W	
3652	061G0603000	RST CHIPR 0 OHM +-5% 1/10W	
3651	061G0603000	RST CHIPR 0 OHM +-5% 1/10W	
3650	061G0603000	RST CHIPR 0 OHM +-5% 1/10W	
3635	061G0603000	RST CHIPR 0 OHM +-5% 1/10W	
3634	061G0603000	RST CHIPR 0 OHM +-5% 1/10W	
3614	061G0603000	RST CHIPR 0 OHM +-5% 1/10W	
3606	061G0603000	RST CHIPR 0 OHM +-5% 1/10W	
3605	061G0603000	RST CHIPR 0 OHM +-5% 1/10W	
3528	061G0603000	RST CHIPR 0 OHM +-5% 1/10W	
3527	061G0603000	RST CHIPR 0 OHM +-5% 1/10W	
3514	061G0603000	RST CHIPR 0 OHM +-5% 1/10W	
3236	061G0603000	RST CHIPR 0 OHM +-5% 1/10W	
3234	061G0603000	RST CHIPR 0 OHM +-5% 1/10W	
3232	061G0603000	RST CHIPR 0 OHM +-5% 1/10W	
3241	061G0603100	RST CHIPR 10 OHM +-5% 1/10W	
3243	061G0603100	RST CHIPR 10 OHM +-5% 1/10W	
3507	061G0603101	RST CHIPR 100 OHM +-5% 1/10W	
3506	061G0603101	RST CHIPR 100 OHM +-5% 1/10W	
3505	061G0603101	RST CHIPR 100 OHM +-5% 1/10W	
3402	061G0603101	RST CHIPR 100 OHM +-5% 1/10W	

3401	061G0603101	RST CHIPR 100 OHM +-5% 1/10W	
3340	061G0603101	RST CHIPR 100 OHM +-5% 1/10W	
3309	061G0603101	RST CHIPR 100 OHM +-5% 1/10W	
3308	061G0603101	RST CHIPR 100 OHM +-5% 1/10W	
3226	061G0603101	RST CHIPR 100 OHM +-5% 1/10W	
3225	061G0603101	RST CHIPR 100 OHM +-5% 1/10W	
3224	061G0603101	RST CHIPR 100 OHM +-5% 1/10W	
3223	061G0603101	RST CHIPR 100 OHM +-5% 1/10W	
3219	061G0603101	RST CHIPR 100 OHM +-5% 1/10W	
3218	061G0603101	RST CHIPR 100 OHM +-5% 1/10W	
3217	061G0603101	RST CHIPR 100 OHM +-5% 1/10W	
3216	061G0603101	RST CHIPR 100 OHM +-5% 1/10W	
3212	061G0603101	RST CHIPR 100 OHM +-5% 1/10W	
3211	061G0603101	RST CHIPR 100 OHM +-5% 1/10W	
3210	061G0603101	RST CHIPR 100 OHM +-5% 1/10W	
3207	061G0603101	RST CHIPR 100 OHM +-5% 1/10W	
3206	061G0603101	RST CHIPR 100 OHM +-5% 1/10W	
3221	061G0603103	RST CHIPR 10 KOHM +-5% 1/10W	
3222	061G0603103	RST CHIPR 10 KOHM +-5% 1/10W	
3617	061G0603103	RST CHIPR 10 KOHM +-5% 1/10W	
3608	061G0603103	RST CHIPR 10 KOHM +-5% 1/10W	
3524	061G0603103	RST CHIPR 10 KOHM +-5% 1/10W	
3523	061G0603103	RST CHIPR 10 KOHM +-5% 1/10W	
3522	061G0603103	RST CHIPR 10 KOHM +-5% 1/10W	
3512	061G0603103	RST CHIPR 10 KOHM +-5% 1/10W	
3511	061G0603103	RST CHIPR 10 KOHM +-5% 1/10W	
3503	061G0603103	RST CHIPR 10 KOHM +-5% 1/10W	
3339	061G0603103	RST CHIPR 10 KOHM +-5% 1/10W	
3338	061G0603103	RST CHIPR 10 KOHM +-5% 1/10W	
3333	061G0603103	RST CHIPR 10 KOHM +-5% 1/10W	
3310	061G0603103	RST CHIPR 10 KOHM +-5% 1/10W	
3307	061G0603103	RST CHIPR 10 KOHM +-5% 1/10W	
3306	061G0603103	RST CHIPR 10 KOHM +-5% 1/10W	
3302	061G0603103	RST CHIPR 10 KOHM +-5% 1/10W	
3301	061G0603103	RST CHIPR 10 KOHM +-5% 1/10W	
3247	061G0603103	RST CHIPR 10 KOHM +-5% 1/10W	
3246	061G0603103	RST CHIPR 10 KOHM +-5% 1/10W	
3242	061G0603103	RST CHIPR 10 KOHM +-5% 1/10W	
3230	061G0603103	RST CHIPR 10 KOHM +-5% 1/10W	
3204	061G0603103	RST CHIPR 10 KOHM +-5% 1/10W	

3203	061G0603103	RST CHIPR 10 KOHM +-5% 1/10W	
3202	061G0603103	RST CHIPR 10 KOHM +-5% 1/10W	
3209	061G0603104	RST CHIPR 100 KOHM +-5% 1/10W	
3229	061G0603104	RST CHIPR 100 KOHM +-5% 1/10W	
3515	061G0603104	RST CHIPR 100 KOHM +-5% 1/10W	
3516	061G0603104	RST CHIPR 100 KOHM +-5% 1/10W	
3611	061G0603104	RST CHIPR 100 KOHM +-5% 1/10W	
3623	061G0603105	RST CHIPR 1M OHM +-5% 1/10W	
3615	061G0603105	RST CHIPR 1M OHM +-5% 1/10W	
3621	061G0603105	RST CHIPR 1M OHM +-5% 1/10W	
3404	061G0603121	RST CHIPR 120 OHM +-5% 1/10W	
3405	061G0603121	RST CHIPR 120 OHM +-5% 1/10W	
3406	061G0603121	RST CHIPR 120 OHM +-5% 1/10W	
3610	061G0603152	RST CHIPR 1.5 KOHM +-5% 1/10W	
3655	061G0603153	RST CHIPR 15KOHM +-5% 1/10W	
3656	061G0603153	RST CHIPR 15KOHM +-5% 1/10W	
3654	061G0603153	RST CHIPR 15KOHM +-5% 1/10W	
3657	061G0603153	RST CHIPR 15KOHM +-5% 1/10W	
3509	061G0603221	RST CHIPR 220 OHM +-5% 1/10W	
3510	061G0603221	RST CHIPR 220 OHM +-5% 1/10W	
3227	061G0603222	RST CHIPR 2.2 KOHM +-5% 1/10W	
3228	061G0603222	RST CHIPR 2.2 KOHM +-5% 1/10W	
3408	061G0603249 0F	RST CHIPR 249 OHM +-1% 1/10W	
3649	061G0603330 9F	RST CHIPR 33 OHM +-1% 1/10W	
3646	061G0603330 9F	RST CHIPR 33 OHM +-1% 1/10W	
3645	061G0603330 9F	RST CHIPR 33 OHM +-1% 1/10W	
3642	061G0603330 9F	RST CHIPR 33 OHM +-1% 1/10W	
3633	061G0603330 9F	RST CHIPR 33 OHM +-1% 1/10W	
3630	061G0603330 9F	RST CHIPR 33 OHM +-1% 1/10W	
3502	061G0603470	RST CHIPR 47 OHM +-5% 1/10W	
3501	061G0603470	RST CHIPR 47 OHM +-5% 1/10W	
3413	061G0603470	RST CHIPR 47 OHM +-5% 1/10W	
3409	061G0603470	RST CHIPR 47 OHM +-5% 1/10W	
3245	061G0603470	RST CHIPR 47 OHM +-5% 1/10W	
3244	061G0603470	RST CHIPR 47 OHM +-5% 1/10W	
3616	061G0603473	RST CHIPR 47 KOHM +-5% 1/10W	
3613	061G0603680 0F	RST CHIPR 680 OHM +-1% 1/10W	
3233	061G0603750 9F	RST CHIPR 75 OHM +-1% 1/10W	
3235	061G0603750 9F	RST CHIPR 75 OHM +-1% 1/10W	
3237	061G0603750 9F	RST CHIPR 75 OHM +-1% 1/10W	

3520	061G0805180 1F	RST CHIPR 1.8 KOHM +-1% 1/8W	
3519	061G0805472	RST CHIPR 4.7 KOHM +-5% 1/8W	
3521	061G0805560 1F	RST CHIPR 5.6 KOHM +-1% 1/8W	
3517	061G1206000	RST CHIPR 0 OHM +-5% 1/4W	
3607	061G1206000	RST CHIPR 0 OHM +-5% 1/4W	
3618	061G1206000	RST CHIPR 0 OHM +-5% 1/4W	
2225	065G0603103 32	CAP CHIP 0603 0.01UF K 50V X7R	
2227	065G0603103 32	CAP CHIP 0603 0.01UF K 50V X7R	
2229	065G0603103 32	CAP CHIP 0603 0.01UF K 50V X7R	
2452	065G0603103 32	CAP CHIP 0603 0.01UF K 50V X7R	
2453	065G0603103 32	CAP CHIP 0603 0.01UF K 50V X7R	
2454	065G0603103 32	CAP CHIP 0603 0.01UF K 50V X7R	
2455	065G0603103 32	CAP CHIP 0603 0.01UF K 50V X7R	
2508	065G0603104 12	CER2 0603 X7R 16V 100N P	
2507	065G0603104 12	CER2 0603 X7R 16V 100N P	
2505	065G0603104 12	CER2 0603 X7R 16V 100N P	
2504	065G0603104 12	CER2 0603 X7R 16V 100N P	
2461	065G0603104 12	CER2 0603 X7R 16V 100N P	
2446	065G0603104 12	CER2 0603 X7R 16V 100N P	
2445	065G0603104 12	CER2 0603 X7R 16V 100N P	
2444	065G0603104 12	CER2 0603 X7R 16V 100N P	
2443	065G0603104 12	CER2 0603 X7R 16V 100N P	
2442	065G0603104 12	CER2 0603 X7R 16V 100N P	
2441	065G0603104 12	CER2 0603 X7R 16V 100N P	
2440	065G0603104 12	CER2 0603 X7R 16V 100N P	
2438	065G0603104 12	CER2 0603 X7R 16V 100N P	
2436	065G0603104 12	CER2 0603 X7R 16V 100N P	
2434	065G0603104 12	CER2 0603 X7R 16V 100N P	
2433	065G0603104 12	CER2 0603 X7R 16V 100N P	
2432	065G0603104 12	CER2 0603 X7R 16V 100N P	
2431	065G0603104 12	CER2 0603 X7R 16V 100N P	
2428	065G0603104 12	CER2 0603 X7R 16V 100N P	
2424	065G0603104 12	CER2 0603 X7R 16V 100N P	
2423	065G0603104 12	CER2 0603 X7R 16V 100N P	
2422	065G0603104 12	CER2 0603 X7R 16V 100N P	
2421	065G0603104 12	CER2 0603 X7R 16V 100N P	
2510	065G0603104 12	CER2 0603 X7R 16V 100N P	
2625	065G0603104 12	CER2 0603 X7R 16V 100N P	
2630	065G0603104 12	CER2 0603 X7R 16V 100N P	
2623	065G0603104 12	CER2 0603 X7R 16V 100N P	

2619	065G0603104 12	CER2 0603 X7R 16V 100N P	
2618	065G0603104 12	CER2 0603 X7R 16V 100N P	
2615	065G0603104 12	CER2 0603 X7R 16V 100N P	
2612	065G0603104 12	CER2 0603 X7R 16V 100N P	
2611	065G0603104 12	CER2 0603 X7R 16V 100N P	
2610	065G0603104 12	CER2 0603 X7R 16V 100N P	
2609	065G0603104 12	CER2 0603 X7R 16V 100N P	
2608	065G0603104 12	CER2 0603 X7R 16V 100N P	
2607	065G0603104 12	CER2 0603 X7R 16V 100N P	
2606	065G0603104 12	CER2 0603 X7R 16V 100N P	
2605	065G0603104 12	CER2 0603 X7R 16V 100N P	
2604	065G0603104 12	CER2 0603 X7R 16V 100N P	
2603	065G0603104 12	CER2 0603 X7R 16V 100N P	
2531	065G0603104 12	CER2 0603 X7R 16V 100N P	
2529	065G0603104 12	CER2 0603 X7R 16V 100N P	
2525	065G0603104 12	CER2 0603 X7R 16V 100N P	
2523	065G0603104 12	CER2 0603 X7R 16V 100N P	
2521	065G0603104 12	CER2 0603 X7R 16V 100N P	
2513	065G0603104 12	CER2 0603 X7R 16V 100N P	
2511	065G0603104 12	CER2 0603 X7R 16V 100N P	
2420	065G0603104 12	CER2 0603 X7R 16V 100N P	
2302	065G0603104 12	CER2 0603 X7R 16V 100N P	
2301	065G0603104 12	CER2 0603 X7R 16V 100N P	
2234	065G0603104 12	CER2 0603 X7R 16V 100N P	
2233	065G0603104 12	CER2 0603 X7R 16V 100N P	
2231	065G0603104 12	CER2 0603 X7R 16V 100N P	
2221	065G0603104 12	CER2 0603 X7R 16V 100N P	
2220	065G0603104 12	CER2 0603 X7R 16V 100N P	
2214	065G0603104 12	CER2 0603 X7R 16V 100N P	
2209	065G0603104 12	CER2 0603 X7R 16V 100N P	
2204	065G0603104 12	CER2 0603 X7R 16V 100N P	
2203	065G0603104 12	CER2 0603 X7R 16V 100N P	
2202	065G0603104 12	CER2 0603 X7R 16V 100N P	
2201	065G0603104 12	CER2 0603 X7R 16V 100N P	
2403	065G0603104 12	CER2 0603 X7R 16V 100N P	
2418	065G0603104 12	CER2 0603 X7R 16V 100N P	
2416	065G0603104 12	CER2 0603 X7R 16V 100N P	
2415	065G0603104 12	CER2 0603 X7R 16V 100N P	
2414	065G0603104 12	CER2 0603 X7R 16V 100N P	
2413	065G0603104 12	CER2 0603 X7R 16V 100N P	

2412	065G0603104 12	CER2 0603 X7R 16V 100N P	
2411	065G0603104 12	CER2 0603 X7R 16V 100N P	
2410	065G0603104 12	CER2 0603 X7R 16V 100N P	
2409	065G0603104 12	CER2 0603 X7R 16V 100N P	
2407	065G0603104 12	CER2 0603 X7R 16V 100N P	
2406	065G0603104 12	CER2 0603 X7R 16V 100N P	
2405	065G0603104 12	CER2 0603 X7R 16V 100N P	
2404	065G0603104 12	CER2 0603 X7R 16V 100N P	
2601	065G0603105 A7	1UF,10V,Y5V, Z	
2602	065G0603105 A7	1UF,10V,Y5V, Z	
2620	065G0603180 31	CAP CC 18PF 50V J NPO 0603	
2621	065G0603180 31	CAP CC 18PF 50V J NPO 0603	
2518	065G0603221 31	CER1 0603 NP0 50V 220P P	
2219	065G0603221 31	CER1 0603 NP0 50V 220P P	
2218	065G0603330 31	CER1 0603 NP0 50V 33P PM	
2451	065G0603479 31	CHIP 0603 4.7PF 50V	
2450	065G0603479 31	CHIP 0603 4.7PF 50V	
2514	065G0603683 12	CHIP 0603 68NF K 16V X7R	
2502	065G0805104 22	0.1UF +-10% 25V X7R 080	
2501	065G0805104 22	0.1UF +-10% 25V X7R 080	
2517	065G0805223 32	CHIP 0.022UF 50V X7R 0805	
2627	065G1206106 A7	CER2 1206 Y5V 10V 10U P8020 R	
2616	067G 312100 3T	SMD 10uf +-20% 16V	
2417	067G 312100 3T	SMD 10uf +-20% 16V	
2417	067G 312100 3T	SMD 10uf +-20% 16V	
2408	067G 312100 3T	SMD 10uf +-20% 16V	
2408	067G 312100 3T	SMD 10uf +-20% 16V	
2417	067G 312100 3T	SMD 10uf +-20% 16V	
2419	067G 312100 3T	SMD 10uf +-20% 16V	
2425	067G 312100 3T	SMD 10uf +-20% 16V	
2426	067G 312100 3T	SMD 10uf +-20% 16V	
2427	067G 312100 3T	SMD 10uf +-20% 16V	
2427	067G 312100 3T	SMD 10uf +-20% 16V	
2427	067G 312100 3T	SMD 10uf +-20% 16V	
2430	067G 312100 3T	SMD 10uf +-20% 16V	
2430	067G 312100 3T	SMD 10uf +-20% 16V	
2430	067G 312100 3T	SMD 10uf +-20% 16V	
2435	067G 312100 3T	SMD 10uf +-20% 16V	
2435	067G 312100 3T	SMD 10uf +-20% 16V	
2435	067G 312100 3T	SMD 10uf +-20% 16V	

2437	067G 312100 3T	SMD 10uf +-20% 16V	
2437	067G 312100 3T	SMD 10uf +-20% 16V	
2437	067G 312100 3T	SMD 10uf +-20% 16V	
2439	067G 312100 3T	SMD 10uf +-20% 16V	
2616	067G 312100 3T	SMD 10uf +-20% 16V	
2616	067G 312100 3T	SMD 10uf +-20% 16V	
2408	067G 312100 3T	SMD 10uf +-20% 16V	
2402	067G 312100 3T	SMD 10uf +-20% 16V	
2401	067G 312100 3T	SMD 10uf +-20% 16V	
2401	067G 312100 3T	SMD 10uf +-20% 16V	
2401	067G 312100 3T	SMD 10uf +-20% 16V	
2439	067G411F1003XT	CAP S105°C 10UF M 16V	
2439	067G411F1003XT	CAP S105°C 10UF M 16V	
2426	067G411F1003XT	CAP S105°C 10UF M 16V	
2426	067G411F1003XT	CAP S105°C 10UF M 16V	
2425	067G411F1003XT	CAP S105°C 10UF M 16V	
2425	067G411F1003XT	CAP S105°C 10UF M 16V	
2419	067G411F1003XT	CAP S105°C 10UF M 16V	
2402	067G411F1003XT	CAP S105°C 10UF M 16V	
2402	067G411F1003XT	CAP S105°C 10UF M 16V	
2503	067G411F4704XT	CAP 105°C 47UF M 25V	
2503	067G411F4704XT	CAP 105°C 47UF M 25V	
2506	067G411F4704XT	CAP 105°C 47UF M 25V	
2506	067G411F4704XT	CAP 105°C 47UF M 25V	
2509	067G411F4704XT	CAP 105°C 47UF M 25V	
2509	067G411F4704XT	CAP 105°C 47UF M 25V	
2460	067G411S1004XT	CAP S105°C 10UF M 25V	
2516	067G411S1004XT	CAP S105°C 10UF M 25V	
5201	071G 56V301 B	CHIP BEAD FCM2012VF-301T07 bullwill	
5202	071G 56V301 B	CHIP BEAD FCM2012VF-301T07 bullwill	
5409	071G 56V301 B	CHIP BEAD FCM2012VF-301T07 bullwill	
5408	071G 56V301 B	CHIP BEAD FCM2012VF-301T07 bullwill	
5407	071G 56V301 B	CHIP BEAD FCM2012VF-301T07 bullwill	
5406	071G 56V301 B	CHIP BEAD FCM2012VF-301T07 bullwill	
5405	071G 56V301 B	CHIP BEAD FCM2012VF-301T07 bullwill	
5404	071G 56V301 B	CHIP BEAD FCM2012VF-301T07 bullwill	
5403	071G 56V301 B	CHIP BEAD FCM2012VF-301T07 bullwill	
5401	071G 56V301 B	CHIP BEAD FCM2012VF-301T07 bullwill	
5302	071G 56V301 B	CHIP BEAD FCM2012VF-301T07 bullwill	
5203	071G 56V301 B	CHIP BEAD FCM2012VF-301T07 bullwill	

5607	071G 57G800 FT	CHIP BEAD TI321611G800 FRONTIER	
5606	071G 57G800 FT	CHIP BEAD TI321611G800 FRONTIER	
5605	071G 57G800 FT	CHIP BEAD TI321611G800 FRONTIER	
5601	071G 57G800 FT	CHIP BEAD TI321611G800 FRONTIER	
5503	071G 57G800 FT	CHIP BEAD TI321611G800 FRONTIER	
5502	071G 57G800 FT	CHIP BEAD TI321611G800 FRONTIER	
5501	071G 57G800 FT	CHIP BEAD TI321611G800 FRONTIER	
5410	071G 57G800 FT	CHIP BEAD TI321611G800 FRONTIER	
5410	071G 57K101 B	CHIP BEAD HCB3216KF-101T30 bullwill	
5501	071G 57K101 B	CHIP BEAD HCB3216KF-101T30 bullwill	
5502	071G 57K101 B	CHIP BEAD HCB3216KF-101T30 bullwill	
5503	071G 57K101 B	CHIP BEAD HCB3216KF-101T30 bullwill	
5601	071G 57K101 B	CHIP BEAD HCB3216KF-101T30 bullwill	
5605	071G 57K101 B	CHIP BEAD HCB3216KF-101T30 bullwill	
5606	071G 57K101 B	CHIP BEAD HCB3216KF-101T30 bullwill	
5607	071G 57K101 B	CHIP BEAD HCB3216KF-101T30 bullwill	
5603	071L 56121 TA	0805 120 OHM 3A	
5604	071L 56121 TA	0805 120 OHM 3A	
6220	093G 60 1P	BAT54LT1 SOT-23	
6223	093G 60 1P	BAT54LT1 SOT-23	
6220	093G 60229	BAT54(L4P)	
6223	093G 60229	BAT54(L4P)	
6202	093G 64 33	DIO SIG SM BAV99 (PHSE)R	
6201	093G 64 33	DIO SIG SM BAV99 (PHSE)R	
6202	093G 64 33	DIO SIG SM BAV99 (PHSE)R	
6202	093G 64 33	DIO SIG SM BAV99 (PHSE)R	
6208	093G 64 33	DIO SIG SM BAV99 (PHSE)R	
6208	093G 64 33	DIO SIG SM BAV99 (PHSE)R	
6208	093G 64 33	DIO SIG SM BAV99 (PHSE)R	
6207	093G 64 33	DIO SIG SM BAV99 (PHSE)R	
6207	093G 64 33	DIO SIG SM BAV99 (PHSE)R	
6207	093G 64 33	DIO SIG SM BAV99 (PHSE)R	
6206	093G 64 33	DIO SIG SM BAV99 (PHSE)R	
6206	093G 64 33	DIO SIG SM BAV99 (PHSE)R	
6206	093G 64 33	DIO SIG SM BAV99 (PHSE)R	
6205	093G 64 33	DIO SIG SM BAV99 (PHSE)R	
6205	093G 64 33	DIO SIG SM BAV99 (PHSE)R	
6205	093G 64 33	DIO SIG SM BAV99 (PHSE)R	
6204	093G 64 33	DIO SIG SM BAV99 (PHSE)R	
6204	093G 64 33	DIO SIG SM BAV99 (PHSE)R	

6204	093G 64 33	DIO SIG SM BAV99 (PHSE)R	
6203	093G 64 33	DIO SIG SM BAV99 (PHSE)R	
6203	093G 64 33	DIO SIG SM BAV99 (PHSE)R	
6203	093G 64 33	DIO SIG SM BAV99 (PHSE)R	
6201	093G 64 33	DIO SIG SM BAV99 (PHSE)R	
6201	093G 64 33	DIO SIG SM BAV99 (PHSE)R	
6221	093G 6432V	LL4148-GSO8	
6221	093G 6432V	LL4148-GSO8	
6222	093G 6432V	LL4148-GSO8	
6222	093G 6432V	LL4148-GSO8	
1601	093G 22S 51 H	CRYSTAL 12.00000MHZ/32PF/HC-49-USM RISHA	
1601	093G 22S 51HEC	RES XTL SM 12MHZ 32 SMD-49 R	
1410	093G 22S 53	14.31818MHZ/20PF	
1601	093G 22S51B H	CRYSTAL 12.00000MHZ/32PH/HC-49-USM RISHA	
6209	093G 39S 66	DIO REG SM BZX84-C5V1 (PHSE)R	
6209	093G 39S 66	DIO REG SM BZX84-C5V1 (PHSE)R	
6221	093G 64S3PH	BAS32L	
6222	093G 64S3PH	BAS32L	
1	715G1854 1	MAIN BOARD PCB	
	Q85G 583615	GASKET_ALUMINIUM FOIL	
	Q85G 583619	GASKET_ALUMINIUM FOIL	
	KEPC780HP1P	KEY BOARD	
1931	033G3802 7	WAFER EH 7	
3935	061G0603103	RST CHIPR 10 KOHM +-5% 1/10W	
3934	061G0603472	RST CHIPR 4.7K OHM +-5% 1/10W	
3933	061G0603473	RST CHIPR 47 KOHM +-5% 1/10W	
1932	077G 604 1 AL	CHIP TACT SWITCH H=1.5 160g SKQGABE010	
1933	077G 604 1 AL	CHIP TACT SWITCH H=1.5 160g SKQGABE010	
1934	077G 604 1 AL	CHIP TACT SWITCH H=1.5 160g SKQGABE010	
1935	077G 604 1 AL	CHIP TACT SWITCH H=1.5 160g SKQGABE010	
1936	077G 604 1 AL	CHIP TACT SWITCH H=1.5 160g SKQGABE010	
1932	077G 604 1 FD	SWI TACT 1P 1POS 12V V 1MM5 R	
1933	077G 604 1 FD	SWI TACT 1P 1POS 12V V 1MM5 R	
1934	077G 604 1 FD	SWI TACT 1P 1POS 12V V 1MM5 R	
1935	077G 604 1 FD	SWI TACT 1P 1POS 12V V 1MM5 R	
1936	077G 604 1 FD	SWI TACT 1P 1POS 12V V 1MM5 R	
6931	081G 14500 KB	LED VS SM KAA-3528YSGC (KIEL)R	
	715G1855 1	KEY BOARD PCB	
E80	PWPC1942LGH5P	POWER BOARD	
34	Q23G3178690 8A	logo	

	Q40G 45769020B	CARTON/PALLET LABEL	
	Q40G19NP690 1E	RATING LABEL	
	Q41G160069041C	L1940T DOC KIT EUR	
	Q41G7800690A19	RTF CARD	
450	Q44G3957690 1F	CARTON	
	Q45G 76 28A05 R	pe bag	
	Q45G 77 5	PE PACKING	
148	Q45G 88609 28 R	BASE P.E BAG	
456	Q45G 88609 29 R	P.E.BAG(EPE)	
457	Q50G 505 19	BELT	
	Q52G6025 13 6	INSULATE SHEET	
	Q85G 583612	GASKET_ALUMINIUM FOIL	
	Q85G 583618	GASKET_ALUMINIUM FOIL	
	040G 58162435A	P/N LABEL FOR MANUAL PE BAG	

Diversity of T981KGNDBHHPQP compared with T981KMNDKHHPQP			
Location	Part No.	Description	Remark
	041G7800690A16	QSG FOR EUR	
	052G 1218 A	SILVER	
E089	089G179E30H712	FFC CABLE	2nd source
E089	089G179J30H712	FFC CABLE	
E089A	089G404A19N IS	POWER CORD	2nd source
E089A	089G404A19N LS	POWER CORD	
	0M1G1730 8120	SCREW	
E750L	750GLG90E3T11Z H	LPL 19" TLB1 ZBD PANEL	
	CBPC980KGNHPP	CONVERSION BOARD G1864-1-X-X-1-070122	
	PWPC1942LGH4P	POWER BOARD G1821-1-X-X-1-070117	
ZD874	093G 39GA01 T	RLZ5.6B	
	Q41G160069041C	L1940T DOC KIT EUR	
	Q85G 583609	GASKET_ALUMINIUM FOIL	
U401	056G 562117(LHPND09GKQ1)	IC NT68663MEFG-128 QFP-128L	
U502	056G1133520CH3	IC AT25040AN-10SU-2.7 ATMEL	

Diversity of T96HNNDBC6HPQP compared with T981KMNDKHPQP			
Location	Part No.	Description	Remark
	041G7800690A16	QSG FOR EUR	
	052G 1210 A	ALUMINIUM TAPE	
E089B	089G 718LAADP1	SIGNAL CABLE D-SUB CABLE GOLDFULL	
E089	089G179E30H712	FFC CABLE	2nd source
E089	089G179J30H712	FFC CABLE	
E089A	089G404A19N IS	POWER CORD	
E089A	089G404A19N LS	POWER CORD	2nd source
	705G980KM34005	MAIN FRAME ASS'Y	
	015G6343 3	MAIN FRAME	
E750L	750GLH9013A81Z000H	PANEL LCD 19" ME13 A16 REV.2 D HP HSD	2nd source
E750L	750GLH9013A82Z000H	PANEL HSD190ME13 A16 REV.2 NJ HSD	
	CBPC980KHNHPP	CONVERSION BOARD G1864-1-X-X-1-070122	
C319	065G0603339 31	CAP:CER 3.3PF 50V SMT 0603	
C321	065G0603339 31	CAP:CER 3.3PF 50V SMT 0603	
	PWPC1942HH1P	POWER BOARD G1821-1-X-X-2-070207	
C936	067G215D2222KV	105°C 2200UF M 10V	
C932	067G215S1024KV	EC 105°C CAP 1000UF M 25V	
C956	067G215Y4713NV	KY16VB470M-CC3 8*15MM	2nd source
C956	067G215Y4713RV	LOW E.S.R 470UF +-20% 16V	
C907	067G215Z10115K	ELCAP 100UF M 450V	
	Q41G160069041C	L1940T DOC KIT EUR	
U401	056G 562117(LHPND09HKQ1)	IC NT68663MEFG-128 QFP-128L	
U502	056G1133520CH3	IC AT25040AN-10SU-2.7 ATMEL	

Diversity of T981KMNDBHHPQP compared with T981KMNDKHPQP			
Location	Part No.	Description	Remark
	041G7800690A16	QSG FOR EUR	
E089B	089G 718WAADP1	CORD SUB-D 15/1M8/SUB-D 15BK	
E089A	089G404A19N IS	POWER CORD	
E089A	089G404A19N LS	POWER CORD	2nd source
	Q41G160069041C	L1940T DOC KIT EUR	

Diversity of T96HNNDKC6HPQP compared with T981KMNDKHPQP			
Location	Part No.	Description	Remark
	052G 1210 A	ALUMINIUM TAPE	
E089B	089G 718LAADP1	SIGNAL CABLE D-SUB CABLE GOLDFULL	2nd source
E089	089G179E30H712	FFC CABLE	2nd source
E089	089G179J30H712	FFC CABLE	
	705G980KM34005	MAIN FRAME ASS'Y	
	015G6343 3	MAIN FRAME	
E750L	750GLH9013A81Z000H	PANEL LCD 19" ME13 A16 REV.2 D HP HSD	2nd source
E750L	750GLH9013A82Z000H	PANEL HSD190ME13 A16 REV.2 NJ HSD	
	CBPC980KHNHPP	CONVERSION BOARD G1864-1-X-X-1-070122	
C319	065G0603339 31	CAP:CER 3.3PF 50V SMT 0603	
C321	065G0603339 31	CAP:CER 3.3PF 50V SMT 0603	
	PWPC1942HH1P	POWER BOARD G1821-1-X-X-2-070207	
C936	067G215D2222KV	105°C 2200UF M 10V	
C932	067G215S1024KV	EC 105°C CAP 1000UF M 25V	
C956	067G215Y4713NV	KY16VB470M-CC3 8*15MM	2nd source
C956	067G215Y4713RV	LOW E.S.R 470UF +-20% 16V	
C907	067G215Z10115K	ELCAP 100UF M 450V	
U401	056G 562117(LHPND09HKQ1)	IC NT68663MEFG-128 QFP-128L	

Diversity of T96GNNDKC6HFQP compared with T981KMNDKHPQP			
Location	Part No.	Description	Remark
	052G 1218 A	SILVER	
E089	089G179E30H712	FFC CABLE	2nd source
E089	089G179J30H712	FFC CABLE	
	0M1G1730 8120	SCREW	
E750L	750GLG90E8B21Z000H	PANEL LM190E08-TLB2 KR LPL	
	CBPC6GNNHPQ2P	CONVERSION BOARD G1864-1-X-X-1-070122	
	PWPC1942LGH4P	POWER BOARD G1821-1-X-X-1-070117	
ZD874	093G 39GA01 T	RLZ5.6B	
	Q85G 583609	GASKET_ALUMINIUM FOIL	

Diversity of T96GNNDMC6HFQ compared with T981KMNDKHPQP			
Location	Part No.	Description	Remark
	052G 1218 A	SILVER	
E089	089G179E30H712	FFC CABLE	2nd source
E089	089G179J30H712	FFC CABLE	
	0M1G1730 8120	SCREW	
E750L	750GLG90E8B21Z000H	PANEL LM190E08-TLB2 KR LPL	
	CBPC6GNNHPQ2P	CONVERSION BOARD G1864-1-X-X-1-070122	
	PWPC1942LGH4P	POWER BOARD G1821-1-X-X-1-070117	
ZD874	093G 39GA01 T	RLZ5.6B	
	Q41G160069040C	DOCKIT L1940T AP	
	Q85G 583609	GASKET_ALUMINIUM FOIL	
U401	056G 562117(LHPND09GKQ2)	IC NT68663MEFG-128 QFP-128L	

Diversity of T96GNNDMC6HPQP compared with T981KMNDKHPQP			
Location	Part No.	Description	Remark
	052G 1218 A	SILVER	
E089	089G179E30H712	FFC CABLE	2nd source
E089	089G179J30H712	FFC	
	0M1G1730 8120	SCREW	
E750L	750GLG90E3T11Z H	LPL 19" TLB1 ZBD PANEL	
	CBPC980KGNHPP	CONVERSION BOARD G1864-1-X-X-1-070122	
	PWPC1942LGH4P	POWER BOARD G1821-1-X-X-1-070117	
ZD874	093G 39GA01 T	RLZ5.6B	
	Q41G160069040C	DOCKIT L1940T AP	
	Q85G 583609	GASKET_ALUMINIUM FOIL	
U401	056G 562117(LHPND09GKQ1)	IC NT68663MEFG-128 QFP-128L	

Diversity of T96HNNDBC6HFQP compared with T981KMNDKHPQP			
Location	Part No.	Description	Remark
	041G7800690A16	QSG FOR EUR	
	052G 1210 A	ALUMINIUM TAPE	
E089	089G179E30H712	FFC CABLE	2nd source
E089	089G179J30H712	FFC	
E089A	089G404A19N IS	POWER CORD	2nd source
E089A	089G404A19N LS	POWER CORD	
	705G980KM34005	MAIN FRAME ASS'Y	
	015G6343 3	MAIN FRAME	
	750GLH903D312Z000H	PANEL HSD190ME13-D30 NJ HSD	
	CBPC6HNNHPQ1P	CONVERSION BOARD G1864-1-X-X-1-070122	
C319	065G0603339 31	CAP:CER 3.3PF 50V SMT 0603	
C321	065G0603339 31	CAP:CER 3.3PF 50V SMT 0603	
	PWPC1942HH1P	POWER BOARD G1821-1-X-X-2-070207	
C936	067G215D2222KV	105°C 2200UF M 10V	
C932	067G215S1024KV	EC 105°C CAP 1000UF M 25V	
C956	067G215Y4713NV	KY16VB470M-CC3 8*15MM	2nd source
C956	067G215Y4713RV	LOW E.S.R 470UF +-20% 16V	
C907	067G215Z10115K	ELCAP 100UF M 450V	
	Q41G160069041C	L1940T DOC KIT EUR	
U401	056G 562117(LHPND09HKQ3)	IC NT68663MEFG-128 QFP-128L	

Diversity of T96HNNDMC6HFQ compared with T981KMNDKHPQP			
Location	Part No.	Description	Remark
	052G 1210 A	ALUMINIUM TAPE	
E089B	089G 718LAADP1	SIGNAL CABLE D-SUB CABLE GOLDFULL	2nd source
E089	089G179E30H712	FFC CABLE	2nd source
E089	089G179J30H712	FFC CABLE	
	705G980KM34005	MAIN FRAME ASS'Y	
	015G6343 3	MAIN FRAME	
	750GLH903D312Z000H	PANEL HSD190ME13-D30 NJ HSD	
	CBPC6HNNHPQ1P	CONVERSION BOARD G1864-1-X-X-1-070122	
C319	065G0603339 31	CAP:CER 3.3PF 50V SMT 0603	
C321	065G0603339 31	CAP:CER 3.3PF 50V SMT 0603	
	PWPC1942HH1P	POWER BOARD G1821-1-X-X-2-070207	
C936	067G215D2222KV	105°C 2200UF M 10V	
C932	067G215S1024KV	EC 105°C CAP 1000UF M 25V	
C956	067G215Y4713NV	KY16VB470M-CC3 8*15MM	2nd source
C956	067G215Y4713RV	LOW E.S.R 470UF +-20% 16V	
C907	067G215Z10115K	ELCAP 100UF M 450V	
	Q41G160069040C	DOCKIT L1940T AP	
U401	056G 562117(LHPND09HKQ3)	IC NT68663MEFG-128 QFP-128L	