

5 BIT – D/A CONVERTER AND POSITION AMPLIFIER

- 5 BIT D/A CONVERTER (1/2 LSB MAX LINEARITY ERROR) ;
- ERROR AMPLIFIER ;
- POSITION AMPLIFIER.

DESCRIPTION

The L291, a monolithic LSI circuit in a 16-lead dual in-line plastic package, is intended for use with the L290 and L292 to form a complete 3 chip DC motor positioning system for applications such as carriage/daisy-wheel position control in typewriters.

The L290/291/292 system can be directly controlled by a microprocessor.

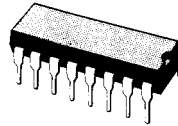

DIP-16
(Plastic 0.25)

ORDER CODE : L291B

ABSOLUTE MAXIMUM RATINGS

Symbol	Parameter	Value	Unit
V_s	Supply Voltage	± 15	V
P_{tot}	Total Power Dissipation $T_{amb} = 70^\circ\text{C}$	1	W
T_{stg}, T_j	Storage and Junction Temperature	-40 to 150	$^\circ\text{C}$

SYSTEM BLOCK DIAGRAM

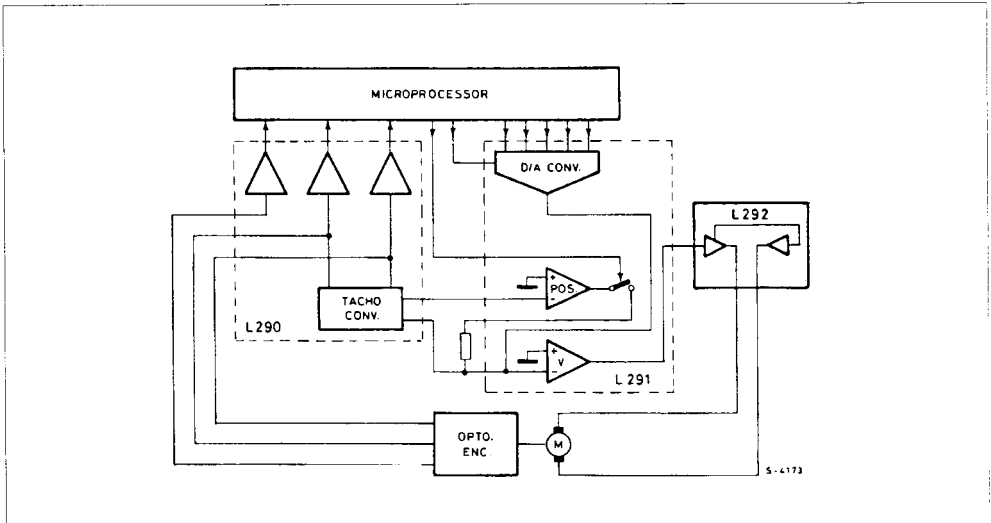

CONNECTION DIAGRAM (top view)

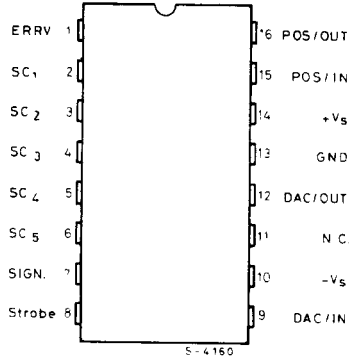

BLOCK DIAGRAM

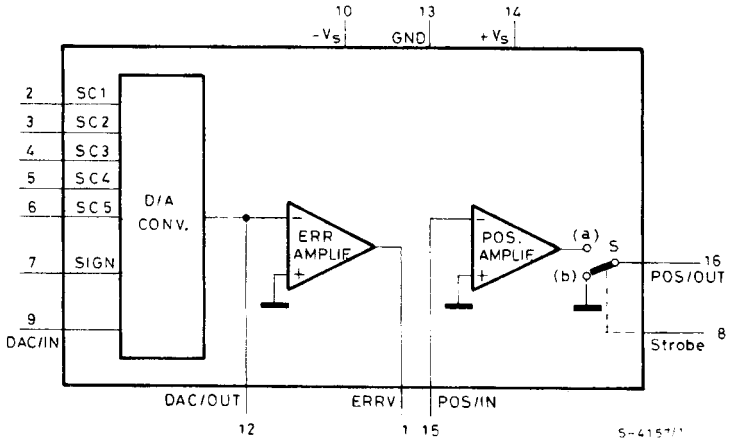

TEST CIRCUIT

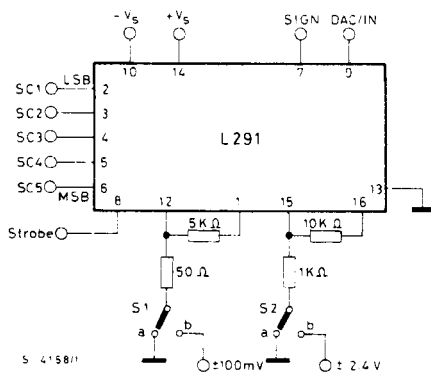

THERMAL DATA

$R_{th\ j-amb}$	Thermal Resistance Junction-ambient	Max	80	C/W
-----------------	-------------------------------------	-----	----	-----

ELECTRICAL CHARACTERISTICS (refer to the circuit, S1 and S2 in (a), $V_s = \pm 12\text{ V}$, $T_{amb} = 25^\circ\text{C}$, unless otherwise specified)

Symbol	Parameter	Test conditions	Min.	Typ.	Max.	Unit
V_s	Supply Voltage		± 10		± 15	V
I_d	Quiescent Drain Current			6.5	10	mA

POSITION AMPLIFIER

V_{strobe}	Enable Voltage Level	$V_L(S \text{ in } (a))$ *	0		0.8	V
		$V_H(S \text{ in } (b))$ *	2.4		$+V_s$	V
V_{os}	Output Offset Voltage (pin 16)	$V_{strobe} = V_L$; $G_v = 20\text{ dB}$			± 50	mV
I_b	Input Bias Current (pin 15)	$V_{strobe} = V_L$			0.3	μA
V_o	Output Voltage Swing (pin 16)	$V_{strobe} = V_L$; S2 in (b); $V_s = \pm 10.8\text{ V}$	± 9			V
V_R	Residual Output Voltage (pin 16)	$V_{strobe} = V_H$			± 20	mV

* See block diagram and the note for Position Amplifier.

ELECTRICAL CHARACTERISTICS (continued)

Symbol	Parameter	Test conditions	Min.	Typ.	Max.	Unit	
I_{ref}	Current Reference Input Range (pin 9)		0.3		1.2	mA	
V_{os}	Current Reference Offset Voltage (pin 9)	$I_{ref} = 0.3$ to 1.2 mA All Inputs High			± 20	mV	
I_o	Output Current Range (pin 12)				1.4	mA	
I_o	Output Current (pin 12)	$I_{ref} = 0.722$ mA SC1 to SC5 = L	SIGN = L(I_{o1})	-1.358	-1.4	-1.442	mA
			SIGN = H(I_{o2})	+1.358	+1.4	+1.442	
ΔI_o		$I_{o1} + I_{o2}$	-21		+21	μ A	
	Linearity Error	$I_{ref} = 0.722$ mA			1.61	%FS	
I_{os}	Pin 12 Output Offset Current (including Error Amplifier bias current)	All Inputs High			± 0.4	μ A	
V_L	Low Voltage Level (digital inputs)	SC1 = LSB	0		0.8	V	
V_H	High Voltage Level (digital inputs)	SC5 = MSB	2.4		+ V_S	V	
I_L	Digital Inputs Current (low state)		$V_L = 0.4$ V		-50	μ A	
I_H	Digital Inputs Current (high state)		$V_H = + V_S$		1	μ A	

ERROR AMPLIFIER

V_{os}	Output Offset Voltage (pin 1)	$I_{ref} = 0.5$ mA : All Inputs High $G_v = 40$ dB			± 200	mV
I_o	Output Current (pin 1)				± 5	mA
V_o	Output Voltage Swing (pin 1)	All Inputs High S1 in (b) : $R_L = 10$ K Ω		± 7.4	± 8.4	Vp

D/A CONVERTER

The L291 contains a 5-bit D/A converter accepting a binary code and generating a bipolar output current, the polarity of which depends on the SIGN input. The amplitude of the output current is a multiple of a reference current I_{ref} .

The maximum output current is

$$I_{FS} = \pm \frac{31}{16} I_{ref}$$

The following table shows the value of I_o for different input codes. Note that the input bits are active low.

DIGITAL INPUT WORD						Output Current
SIGN	SC5 MSB	SC4	SC3	SC2	SC1 LSB	I_o
L	L	L	L	L	L	$-\frac{31}{16} I_{ref}$
L	H	H	H	H	L	$-\frac{1}{16} I_{ref}$
X	H	H	H	H	H	0
H	H	H	H	H	L	$+\frac{1}{16} I_{ref}$
H	L	L	L	L	L	$+\frac{31}{16} I_{ref}$

X = indifferent

L = low

H = high

This D/A converter has a maximum linearity error equal to $\pm 1/2$ LSB (or $\pm 1.61\%$ Full Scale) ; that guarantees its monotonicity.

ERROR AMPLIFIER

In order to have a good stability, the Error Amplifier must work with a closed loop gain greater or equal than 20 dB.

POSITION AMPLIFIER

It is inserted by means of the strobe signal, TTL and microprocessor compatible. Its output is connected to pin 16 when $V_{strobe} = \text{Low}$; pin 16 is grounded for $V_{strobe} = \text{High}$.

SYSTEM DESCRIPTION : refer to the L292 data sheet.

Figure 1 : Complete Application Circuit.

