



L293B L293E

PUSH-PULL FOUR CHANNEL DRIVERS

- OUTPUT CURRENT 1A PER CHANNEL
- PEAK OUTPUT CURRENT 2A PER CHANNEL (non repetitive)
- INHIBIT FACILITY
- HIGH NOISE IMMUNITY
- SEPARATE LOGIC SUPPLY
- OVERTEMPERATURE PROTECTION

DESCRIPTION

The L293B and L293E are quad push-pull drivers capable of delivering output currents to 1A per channel. Each channel is controlled by a TTL-compatible logic input and each pair of drivers (a full bridge) is equipped with an inhibit input which turns off all four transistors. A separate supply input is provided for the logic so that it may be run off a lower voltage to reduce dissipation.

Additionally, the L293E has external connection of

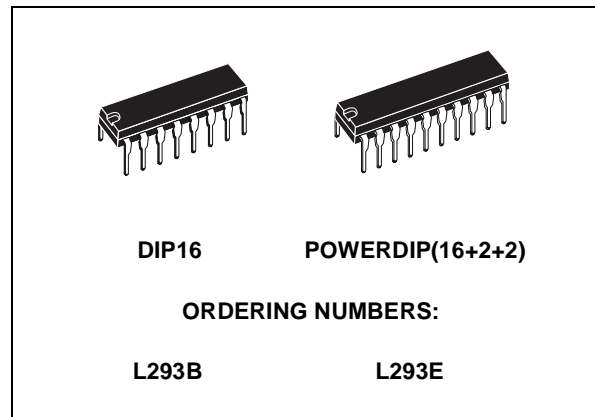

sensing resistors, for switchmode control.

The L293B and L293E are package in 16 and 20-pin plastic DIPs respectively ; both use the four center pins to conduct heat to the printed circuit board.

PIN CONNECTION (Top view)

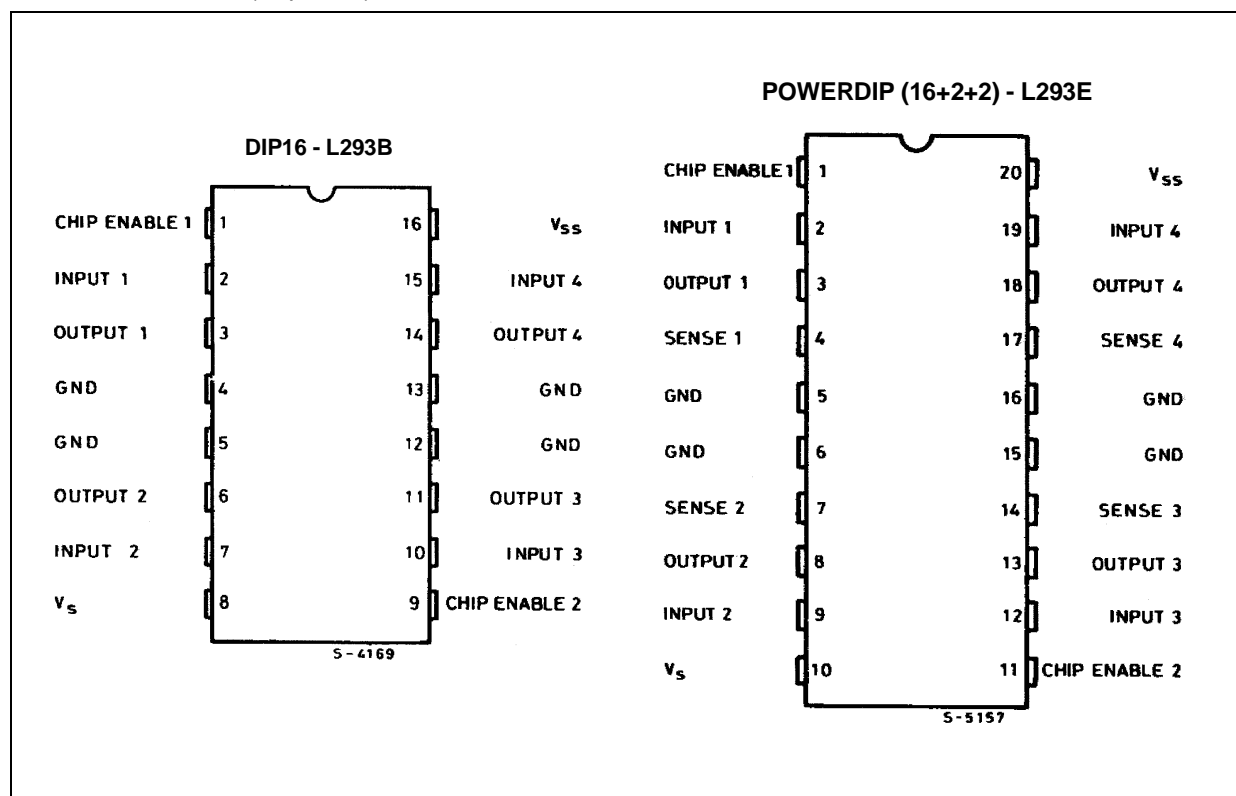

BLOCK DIAGRAMS

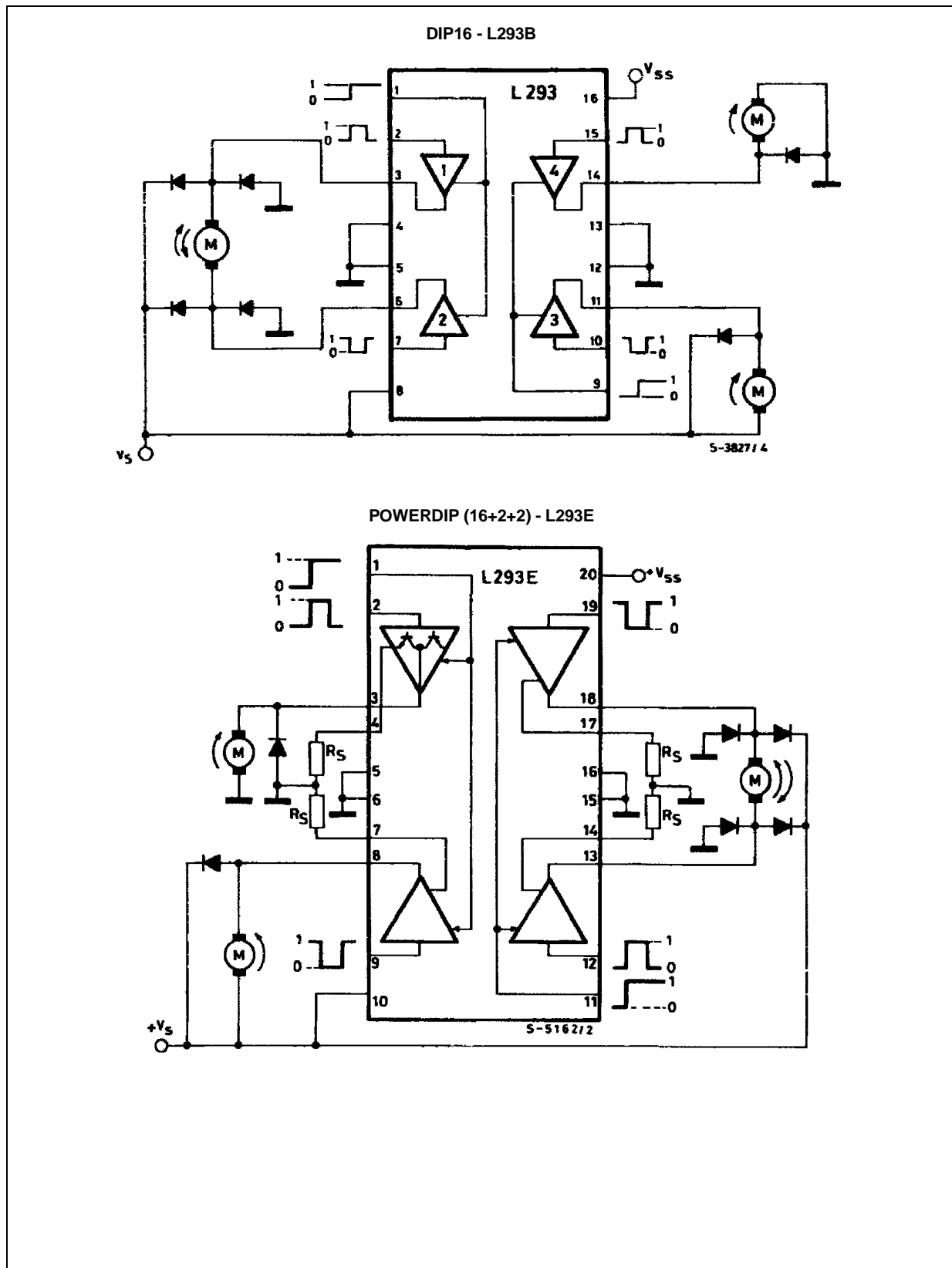

SCHEMATIC DIAGRAM

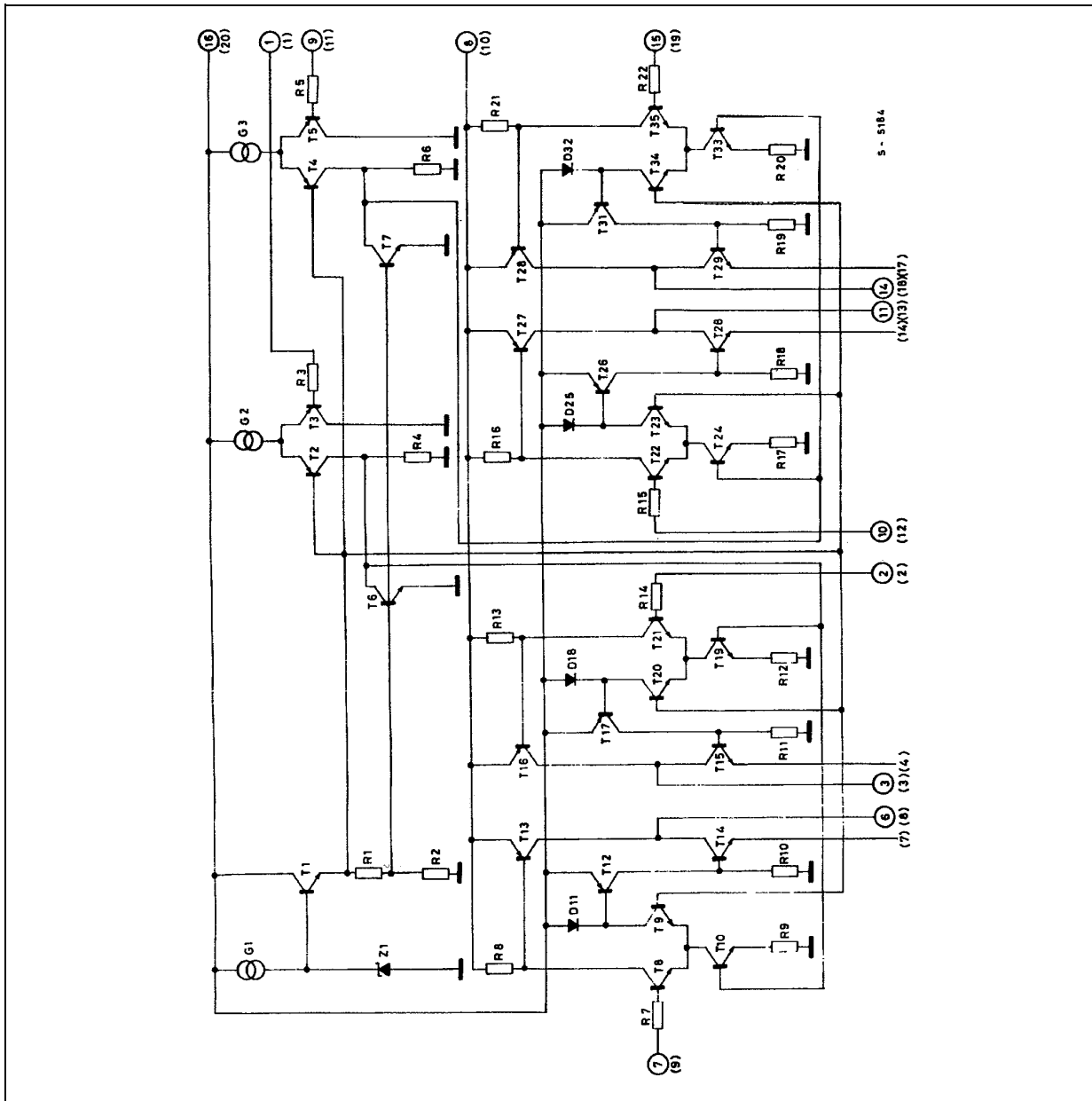

(*) In the L293 these points are not externally available. They are internally connected to the ground (substrate).
 O Pins of L293 () Pins of L293E.

ABSOLUTE MAXIMUM RATINGS

| Symbol | Parameter | Value | Unit |
|----------------|--|-------------|-------------|
| V_s | Supply Voltage | 36 | V |
| V_{ss} | Logic Supply Voltage | 36 | V |
| V_i | Input Voltage | 7 | V |
| V_{inh} | Inhibit Voltage | 7 | V |
| I_{out} | Peak Output Current (non repetitive $t = 5ms$) | 2 | A |
| P_{tot} | Total Power Dissipation at $T_{ground-pins} = 80^{\circ}C$ | 5 | W |
| T_{stg}, T_j | Storage and Junction Temperature | -40 to +150 | $^{\circ}C$ |



L293E L293B

THERMAL DATA

| Symbol | Parameter | Value | Unit |
|------------------|-------------------------------------|---------|------|
| $R_{th\ j-case}$ | Thermal Resistance Junction-case | Max. 14 | °C/W |
| $R_{th\ j-amb}$ | Thermal Resistance Junction-ambient | Max. 80 | °C/W |

ELECTRICAL CHARACTERISTICS

| Symbol | Parameter | Test Condition | Min. | Typ. | Max. | Unit |
|--------------|--|---|----------|------|----------|------|
| V_s | Supply Voltage | | V_{SS} | | 36 | V |
| V_{SS} | Logic Supply Voltage | | 4.5 | | 36 | V |
| I_s | Total Quiescent Supply Current | $V_i = L; I_o = 0; V_{inh} = H$ | | 2 | 6 | mA |
| | | $V_i = h; I_o = 0; V_{inh} = H$ | | 16 | 24 | mA |
| | | $V_{inh} = L$ | | | 4 | mA |
| I_{SS} | Total Quiescent Logic Supply Current | $V_i = L; I_o = 0; V_{inh} = H$ | | 44 | 60 | mA |
| | | $V_i = h; I_o = 0; V_{inh} = H$ | | 16 | 22 | mA |
| | | $V_{inh} = L$ | | 16 | 24 | mA |
| V_{iL} | Input Low Voltage | | -0.3 | | 1.5 | V |
| V_{iH} | Input High Voltage | $V_{SS} \leq 7V$ | 2.3 | | V_{SS} | V |
| | | $V_{SS} > 7V$ | 2.3 | | 7 | V |
| I_{iL} | Low Voltage Input Current | $V_{iL} = 1.5V$ | | | -10 | μA |
| I_{iH} | High Voltage Input Current | $2.3V \leq V_{iH} \leq V_{SS} - 0.6V$ | | 30 | 100 | μA |
| V_{inhL} | Inhibit Low Voltage | | -0.3 | | 1.5 | V |
| V_{inhH} | Inhibit High Voltage | $V_{SS} \leq 7V$ | 2.3 | | V_{SS} | V |
| | | $V_{SS} > 7V$ | 2.3 | | 7 | V |
| I_{inhL} | Low Voltage Inhibit Current | $V_{inhL} = 1.5V$ | | -30 | -100 | μA |
| I_{inhH} | High Voltage Inhibit Current | $2.3V \leq V_{inhH} \leq V_{SS} - 0.6V$ | | | ±10 | μA |
| V_{CEsatH} | Source Output Saturation Voltage | $I_o = -1A$ | | 1.4 | 1.8 | V |
| V_{CEsatL} | Sink Output Saturation Voltage | $I_o = 1A$ | | 1.2 | 1.8 | V |
| V_{SENS} | Sensing Voltage (pins 4, 7, 14, 17) (**) | | | | 2 | V |
| t_r | Rise Time | 0.1 to 0.9 V_o (*) | | 250 | | ns |
| t_f | Fall Time | 0.9 to 0.1 V_o (*) | | 250 | | ns |
| t_{on} | Turn-on Delay | 0.5 V_i to 0.5 V_o (*) | | 750 | | ns |
| t_{off} | Turn-off Delay | 0.5 V_i to 0.5 V_o (*) | | 200 | | ns |

* See figure 1

** Referred to L293E

TRUTH TABLE

| V_i (each channel) | V_o | V_{inh} (**) |
|----------------------|-------|----------------|
| H | H | H |
| L | L | H |
| H | X (*) | L |
| L | X (*) | L |

(*) High output impedance

(**) Relative to the considerate channel

Figure 1. Switching Timers

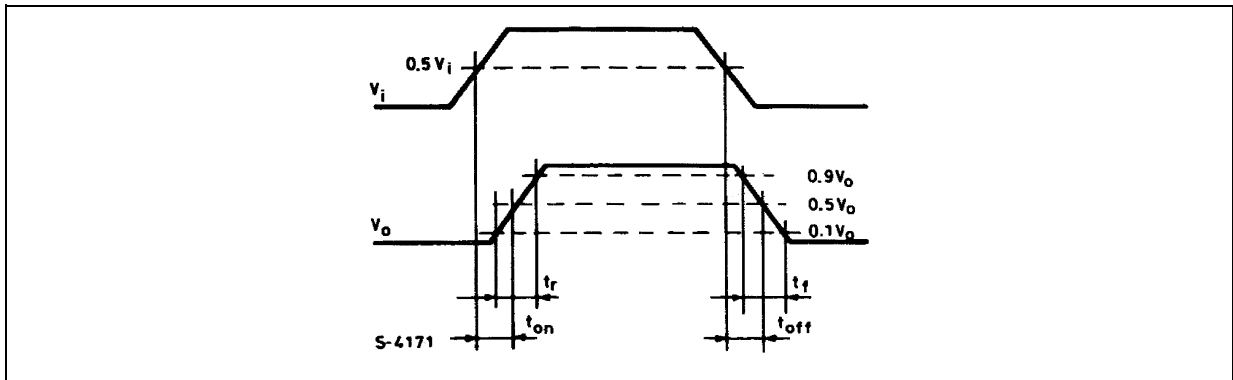

Figure 2. Saturation voltage versus Output Current

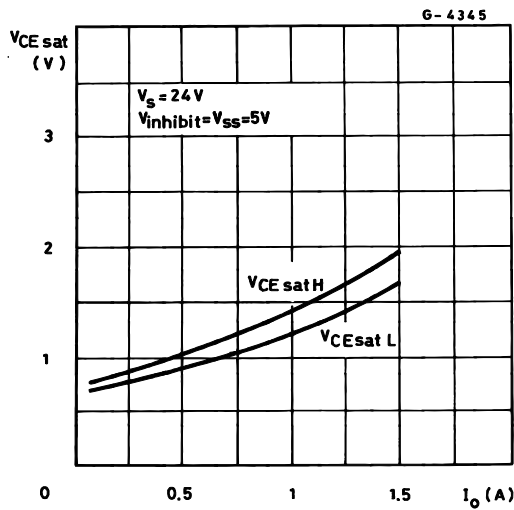

Figure 3. Source Saturation Voltage versus Ambient Temperature

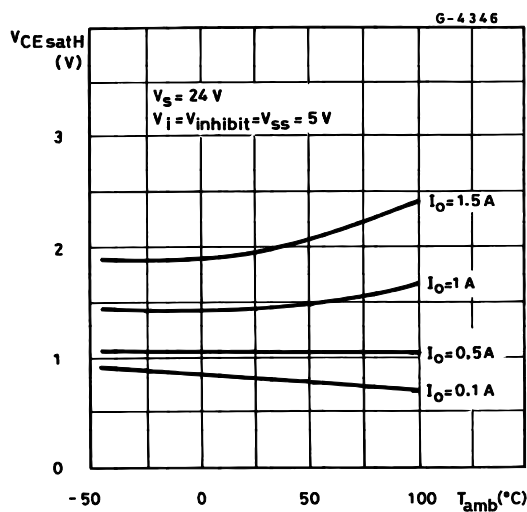

Figure 4. Sink Saturation Voltage versus Ambient Temperature

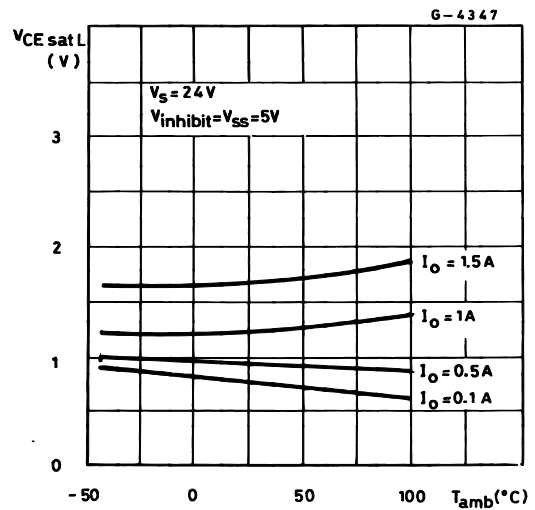

Figure 5. Quiescent Logic Supply Current versus Logic Supply Voltage

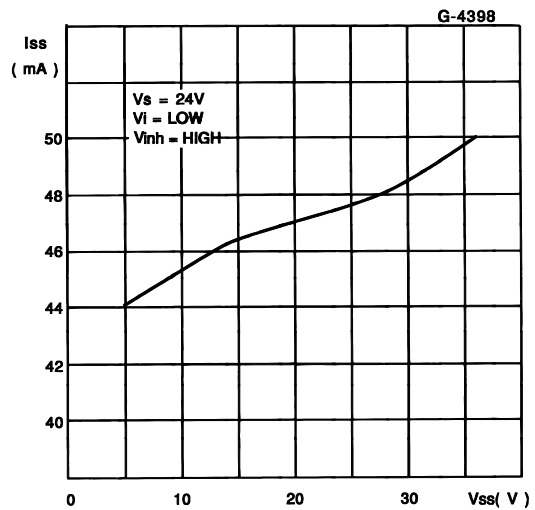

Figure 6. Output Voltage versus Input Voltage

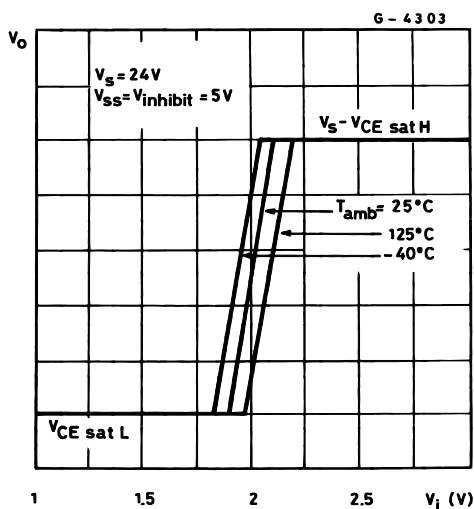
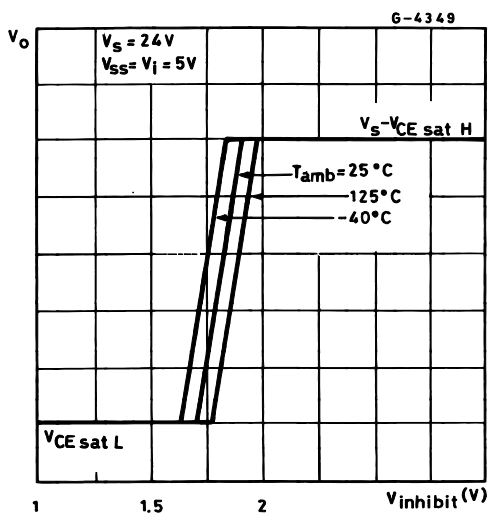
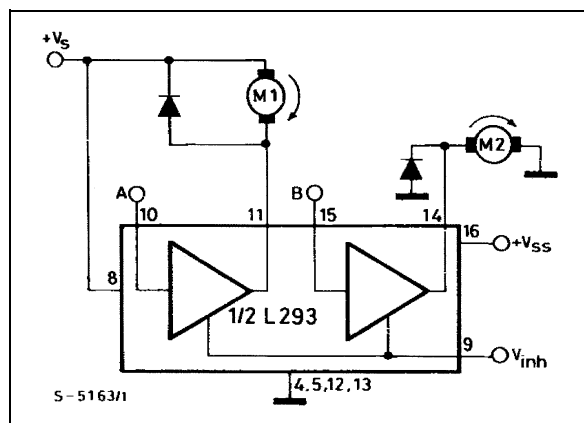

Figure 7. Output Voltage versus Inhibit Voltage



APPLICATION INFORMATION

Figure 8. DC Motor Controls (with connection to ground and to the supply voltage)



| V_{inh} | A | M1 | B | M2 |
|-----------|---|-----------------|---|-----------------|
| H | H | Fast Motor Stop | H | Run |
| H | L | Run | L | Fast Motor Stop |
| L | X | Free Running | X | Free Running |
| | | Motor Stop | | Motor Stop |

L = Low H = High X = Don't Care

Figure 9. Bidirectional DC Motor Control

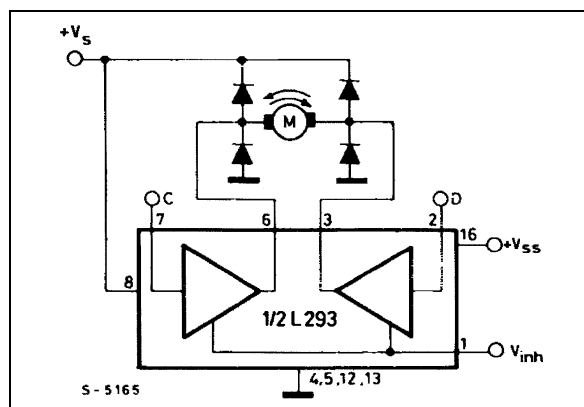

| Inputs | Function | |
|---------------|---------------|-------------------------|
| $V_{inh} = H$ | C = H ; D = L | Turn Right |
| | C = L ; D = H | Turn Left |
| | C = D | Fast Motor Stop |
| $V_{inh} = L$ | C = X ; D = X | Free Running Motor Stop |

L = Low H = High X = Don't Care

Figure 10. Bipolar Stepping Motor Control

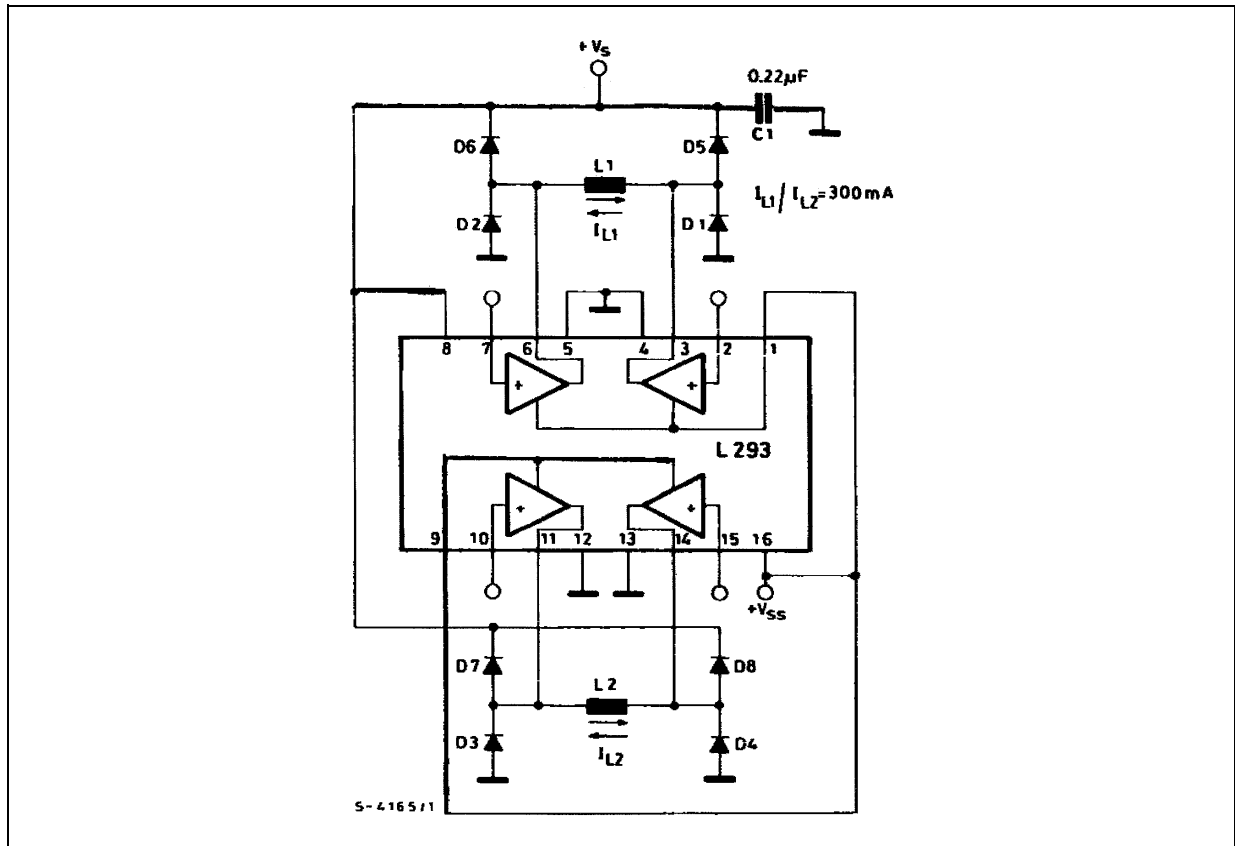
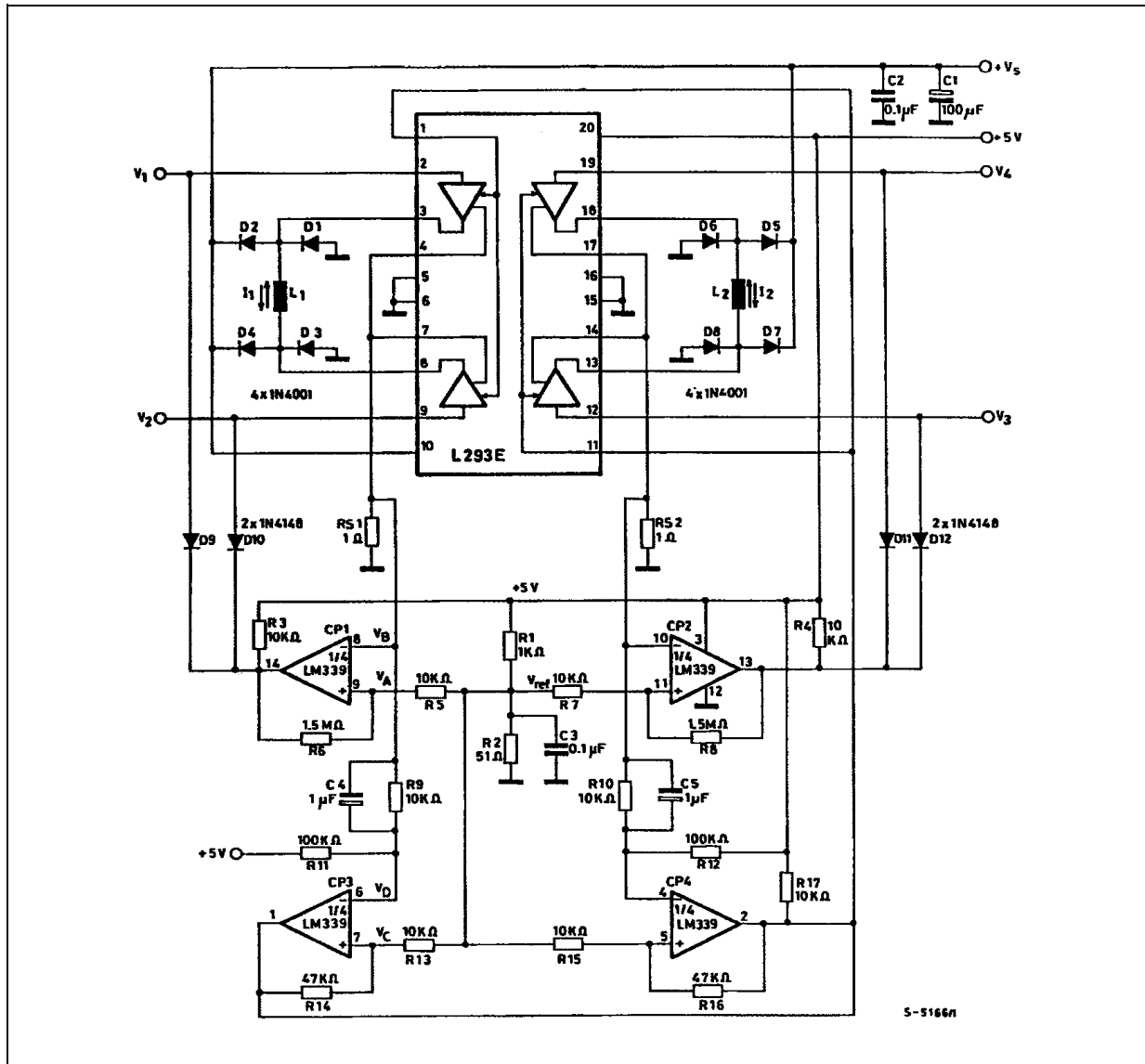

Figure 11. Stepping Motor Driver with Phase Current Control and Short Circuit Protection



MOUNTING INSTRUCTIONS

The $R_{thj-amb}$ of the L293B and the L293E can be reduced by soldering the GND pins to a suitable copper area of the printed circuit board as shown in figure 12 or to an external heatsink (figure 13).

During soldering the pins temperature must not exceed 260°C and the soldering time must not be longer than 12 seconds.

The external heatsink or printed circuit copper area must be connected to electrical ground.

Figure 12. Example of P.C. Board Copper Area which is Used as Heatsink

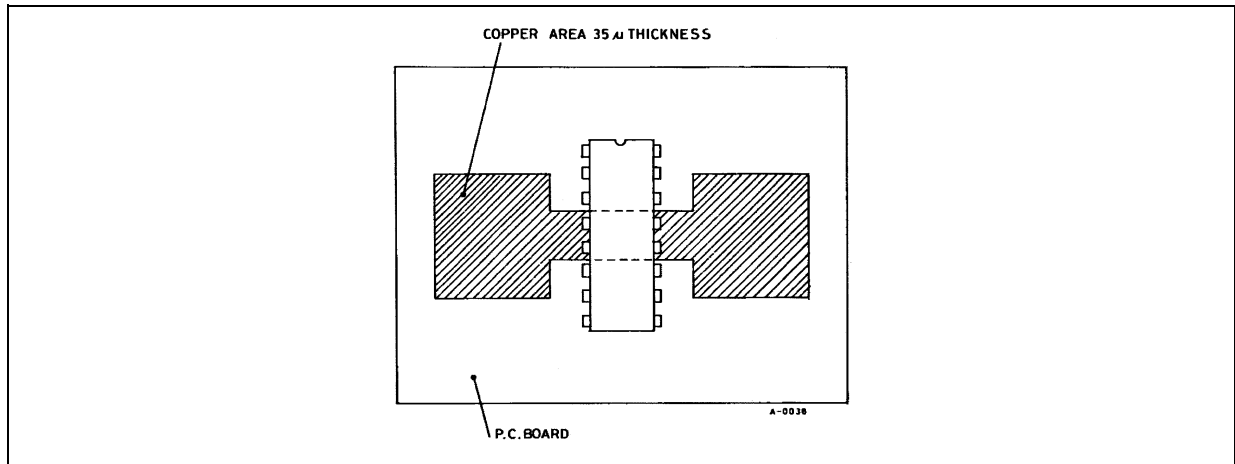
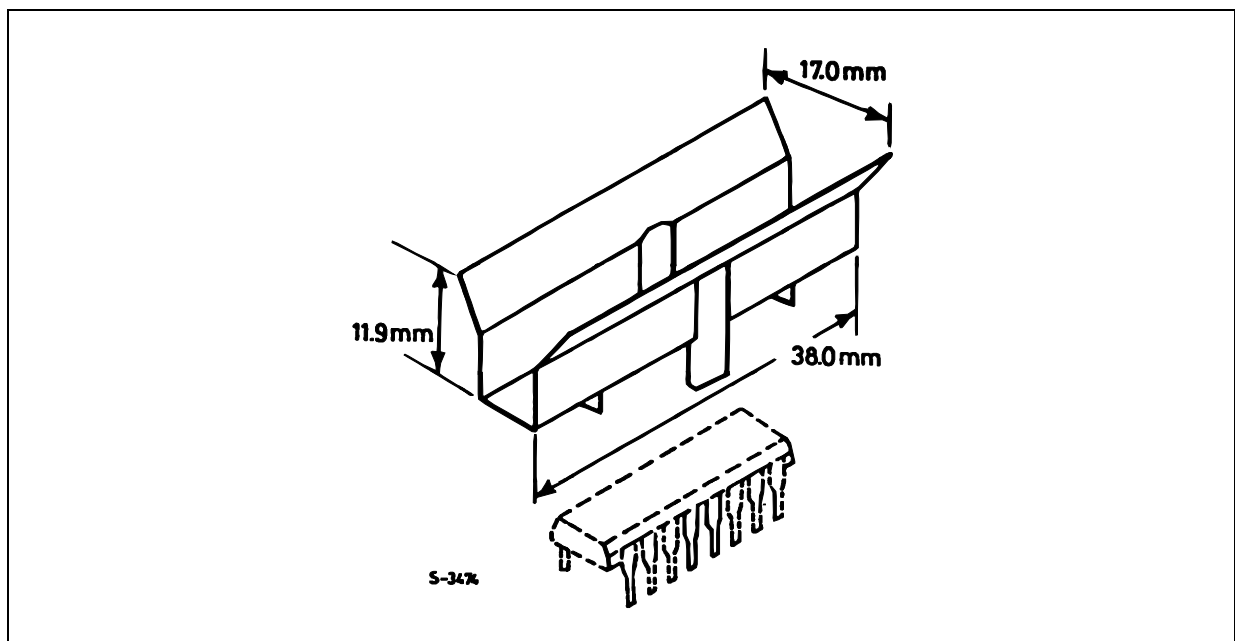
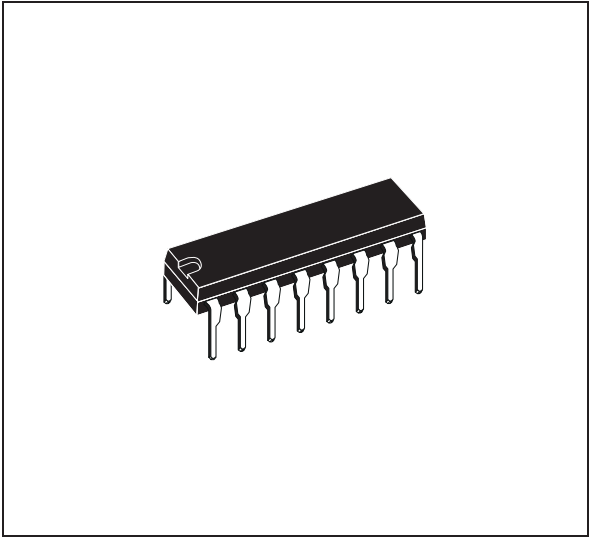

Figure 13. External Heatsink Mounting Example ($R_{th} = 30^{\circ}\text{C/W}$)



| DIM. | mm | | | inch | | |
|------|------|-------|------|-------|-------|-------|
| | MIN. | TYP. | MAX. | MIN. | TYP. | MAX. |
| a1 | 0.51 | | | 0.020 | | |
| B | 0.77 | | 1.65 | 0.030 | | 0.065 |
| b | | 0.5 | | | 0.020 | |
| b1 | | 0.25 | | | 0.010 | |
| D | | | 20 | | | 0.787 |
| E | | 8.5 | | | 0.335 | |
| e | | 2.54 | | | 0.100 | |
| e3 | | 17.78 | | | 0.700 | |
| F | | | 7.1 | | | 0.280 |
| I | | | 5.1 | | | 0.201 |
| L | | 3.3 | | | 0.130 | |
| Z | | | 1.27 | | | 0.050 |

OUTLINE AND MECHANICAL DATA



DIP16

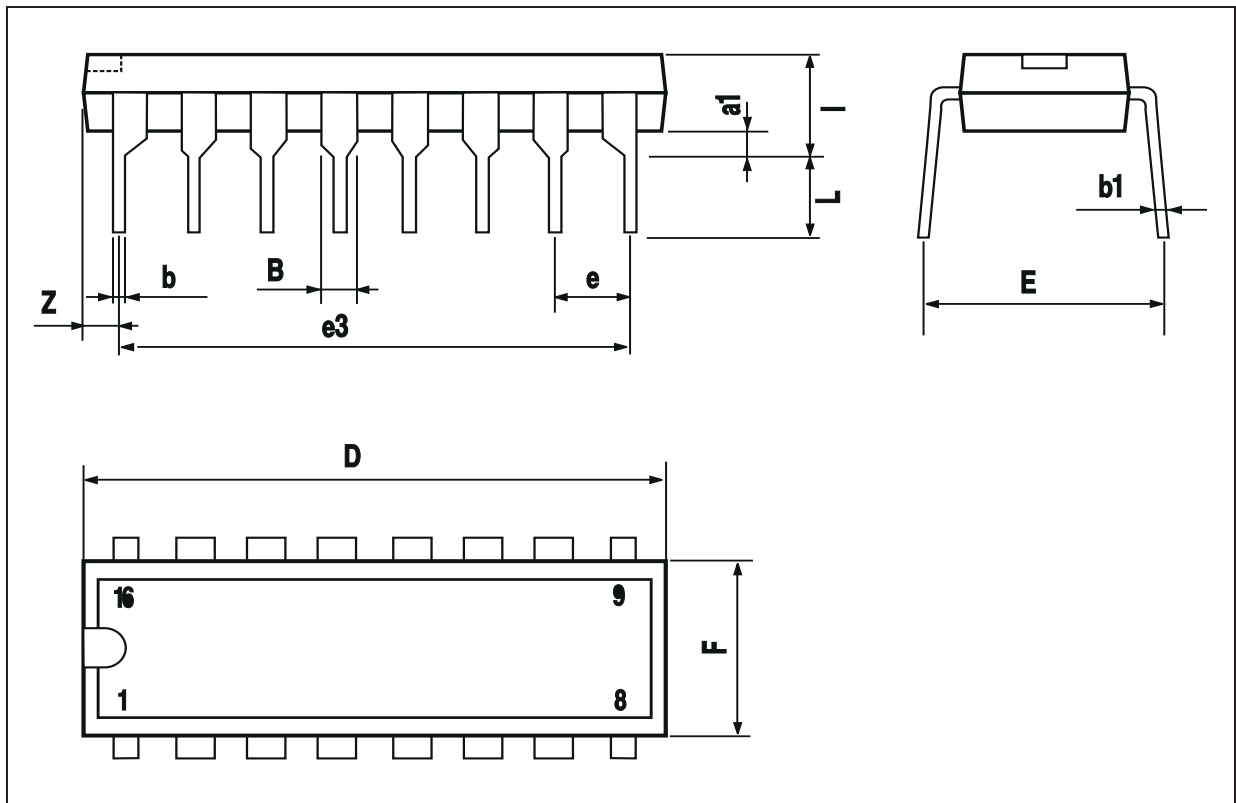

| DIM. | mm | | | inch | | |
|------|------|-------|-------|-------|-------|-------|
| | MIN. | TYP. | MAX. | MIN. | TYP. | MAX. |
| a1 | 0.51 | | | 0.020 | | |
| B | 0.85 | | 1.40 | 0.033 | | 0.055 |
| b | | 0.50 | | | 0.020 | |
| b1 | 0.38 | | 0.50 | 0.015 | | 0.020 |
| D | | | 24.80 | | | 0.976 |
| E | | 8.80 | | | 0.346 | |
| e | | 2.54 | | | 0.100 | |
| e3 | | 22.86 | | | 0.900 | |
| F | | | 7.10 | | | 0.280 |
| I | | | 5.10 | | | 0.201 |
| L | | 3.30 | | | 0.130 | |
| Z | | | 1.27 | | | 0.050 |

OUTLINE AND MECHANICAL DATA

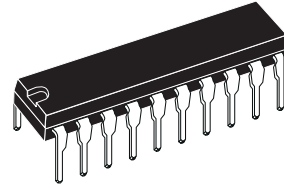

Powerdip 20

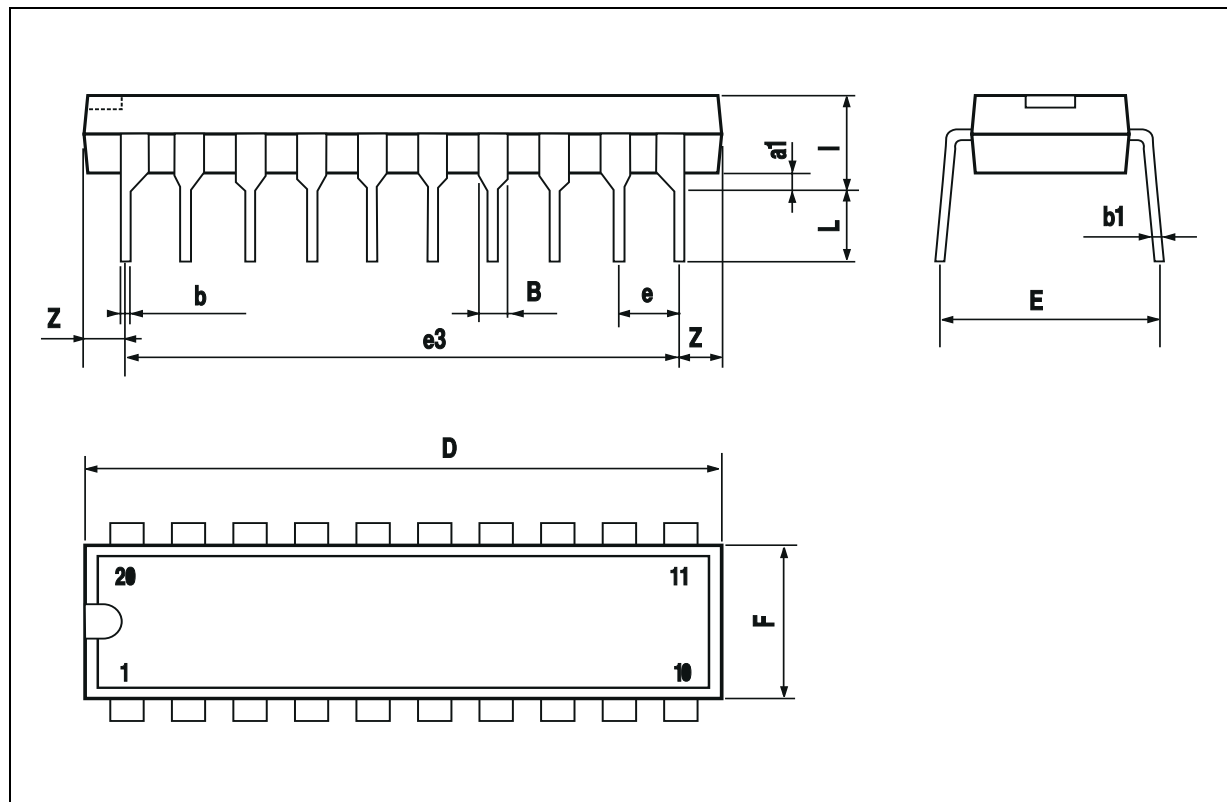

Information furnished is believed to be accurate and reliable. However, STMicroelectronics assumes no responsibility for the consequences of use of such information nor for any infringement of patents or other rights of third parties which may result from its use. No license is granted by implication or otherwise under any patent or patent rights of STMicroelectronics. Specifications mentioned in this publication are subject to change without notice. This publication supersedes and replaces all information previously supplied. STMicroelectronics products are not authorized for use as critical components in life support devices or systems without express written approval of STMicroelectronics.

STMicroelectronics acknowledges the trademarks of all companies referred to in this document.

The ST logo is a registered trademark of STMicroelectronics
© 2003 STMicroelectronics - All Rights Reserved

STMicroelectronics GROUP OF COMPANIES
Australia - Brazil - Canada - China - Finland - France - Germany - Hong Kong - India - Israel - Italy - Japan - Malaysia - Malta - Morocco -
Singapore - Spain - Sweden - Switzerland - United Kingdom - United States.
<http://www.st.com>